

Acer Altos 1200LP
User's guide

Copyright © 2000 Acer Incorporated
All Rights Reserved.

Acer Altos 1200LP
User's guide

Changes may be made periodically to the information in this publication without obligation to notify any person of such revision or changes. Such changes will be incorporated in new editions of this manual or supplementary documents and publications. This company makes no representations or warranties, either expressed or implied, with respect to the contents hereof and specifically disclaims the implied warranties of merchantability or fitness for a particular purpose.

Record the model number, serial number, purchase date, and place of purchase information in the space provided below. The serial number and model number are recorded on the label affixed to your computer. All correspondence concerning your unit should include the serial number, model number, and purchase information.

No part of this publication may be reproduced, stored in a retrieval system, or transmitted, in any form or by any means, electronic, mechanical, photocopy, recording, or otherwise, without the prior written permission of Acer Incorporated.

Model Number : _____

Serial Number: _____

Purchase Date: _____

Place of Purchase: _____

Acer and the Acer Logo are registered trademarks of Acer Inc. Other company's product names or trademarks are used herein for identification purposes only and belong to their respective companies.

Notices

FCC notice

This device has been tested and found to comply with the limits for a Class B digital device pursuant to Part 15 of the FCC Rules. These limits are designed to provide reasonable protection against harmful interference in a residential installation. This device generates, uses, and can radiate radio frequency energy and, if not installed and used in accordance with the instructions, may cause harmful interference to radio communications.

However, there is no guarantee that interference will not occur in a particular installation. If this device does cause harmful interference to radio or television reception, which can be determined by turning the device off and on, the user is encouraged to try to correct the interference by one or more of the following measures:

- Reorient or relocate the receiving antenna
- Increase the separation between the device and receiver
- Connect the device into an outlet on a circuit different from that to which the receiver is connected
- Consult the dealer or an experienced radio/television technician for help

Notice: Shield cables

All connections to other computing devices must be made using shielded cables to maintain compliance with FCC regulations.

Notice: Peripheral devices

Only peripherals (input/output devices, terminals, printers, etc.) certified to comply with the Class B limits may be attached to this equipment. Operation with noncertified peripherals is likely to result in interference to radio and TV reception.



.....
Caution! Changes or modifications not expressly approved by the manufacturer could void the user's authority, which is granted by the Federal Communications Commission, to operate this computer.

Use conditions

This part complies with Part 15 of the FCC Rules. Operation is subject to the following two conditions: (1) this device may not cause harmful interference, and (2) this device must accept any interference received, including interference that may cause undesired operation.

Notice: Canadian users

This Class B digital apparatus meets all requirements of the Canadian Interference-Causing Equipment Regulations.

Remarque à l'intention des utilisateurs canadiens

Cet appareil numérique de la classe B respecte toutes les exigences du Règlement sur le matériel brouilleur du Canada.

Important safety instructions

Read these instructions carefully. Save these instructions for future reference.

1. Follow all warnings and instructions marked on the product.
2. Unplug this product from the wall outlet before cleaning. Do not use liquid cleaners or aerosol cleaners. Use a damp cloth for cleaning.
3. Do not use this product near water.
4. Do not place this product on an unstable cart, stand, or table. The product may fall, causing serious damage to the product.
5. Slots and openings in the cabinet and the back or bottom are provided for ventilation; to ensure reliable operation of the product and to protect it from overheating, these openings must not be blocked or covered. The openings should never be blocked by placing the product on a bed, sofa, rug, or other similar surface. This product should never be placed near or over a radiator or heat register, or in a built-in installation unless proper ventilation is provided.
6. This product should be operated from the type of power indicated on the marking label. If you are not sure of the type of power available, consult your dealer or local power company.

7. Do not allow anything to rest on the power cord. Do not locate this product where persons will walk on the cord.
8. If an extension cord is used with this product, make sure that the total ampere rating of the equipment plugged into the extension cord does not exceed the extension cord ampere rating. Also, make sure that the total rating of all products plugged into the wall outlet does not exceed the fuse rating.
9. Never push objects of any kind into this product through cabinet slots as they may touch dangerous voltage points or short out parts that could result in a fire or electric shock. Never spill liquid of any kind on the product.
10. Do not attempt to service this product yourself, as opening or removing covers may expose you to dangerous voltage points or other risks. Refer all servicing to qualified service personnel.
11. Unplug this product from the wall outlet and refer servicing to qualified service personnel under the following conditions:
 - a. When the power cord or plug is damaged or frayed
 - b. If liquid has been spilled into the product
 - c. If the product has been exposed to rain or water
 - d. If the product does not operate normally when the operating instructions are followed. Adjust only those controls that are covered by the operating instructions since improper adjustment of other controls may result in damage and will often require extensive work by a qualified technician to restore the product to normal condition.
 - e. If the product has been dropped or the cabinet has been damaged
 - f. If the product exhibits a distinct change in performance, indicating a need for service.
12. Replace the battery with the same type as the product's battery we recommend. Use of another battery may present a risk of fire or explosion. Refer battery replacement to a qualified serviceman.
13. Warning! Batteries may explode if not handled properly. Do not disassemble or dispose of them in fire. Keep them away from children and dispose of used batteries promptly.

14. Use only the proper type of power supply cord set (provided in your accessories box) for this unit. It should be a detachable type: UL listed/CSA certified, type SPT-2, rated 7A 125V minimum, VDE approved or its equivalent. Maximum length is 15 feet (4.6 meters).

Laser compliance statement

The CD-ROM drive in this computer is a laser product. The CD-ROM drive's classification label (shown below) is located on the drive.

CLASS 1 LASER PRODUCT

CAUTION: INVISIBLE LASER RADIATION WHEN OPEN. AVOID EXPOSURE TO BEAM.

APPAREIL A LASER DE CLASSE 1 PRODUIT

LASERATTENTION: RADIATION DU FAISCEAU LASER INVISIBLE EN CAS D'OUVERTURE. EVITER TOUTE EXPOSITION AUX RAYONS.

LASER KLASSE 1

VORSICHT: UNSICHTBARE LASERSTRAHLUNG, WENN ABDECKUNG GEÖFFNET, NICHT DEM STRAHLL AUSSETZEN

PRODUCTO LÁSER DE LA CLASE I

ADVERTENCIA: RADIACIÓN LÁSER INVISIBLE AL SER ABIERTO. EVITE EXPONERSE A LOS RAYOS.

ADVARSEL: LASERSTRÅLING VEDÅBNING SE IKKE IND I STRÅLEN

VARO! LAVATTAESSA OLET ALTTINA LASERSÄTEILYLLE.

VARNING: LASERSTRÅLNING NÅR DENNA DEL ÅR ÖPPNAD ÅLÅ TUIJOTA SÄTEESEENSTIRRA EJ IN I STRÅLEN

VARNING: LASERSTRÅLNING NAR DENNA DEL ÅR ÖPPNADSTIRRA EJ IN I STRÅLEN

ADVARSEL: LASERSTRÅLING NAR DEKSEL ÅPNESSTIRR IKKE INN I STRÅLEN

Lithium battery statement

CAUTION

Danger of explosion if battery is incorrectly replaced. Replace only with the same or equivalent type recommended by the manufacturer. Discard used batteries according to the manufacturer's instructions.

ADVARSEL!

Lithiumbatteri - Eksplosionsfare ved fejlagtig håndtering. Udskiftning må kun ske med batteri af samme fabrikat og type. Léver det brugte batteri tilbage til leverandøren.

ADVARSEL

Eksplosjonsfare ved feilaktig skifte av batteri. Benytt samme batteritype eller en tilsvarende type anbefalt av apparatfabrikanten. Brukte batterier kasseres i henhold til fabrikantens instruksjoner.

WARNING

Explosionsfara vid felaktigt batteribyte. Använd samma batterityp eller en ekvivalent typ som rekommenderas av apparattillverkaren. Kassera använt batteri enligt fabrikantens instruktion.

VAROITUS

Päristo voi räjähtää, jos se on virheellisesti asennettu. Vaihda paristo ainoastaan laitevalmistajan suosittelemaan tyyppiin. Hävitä käytetty paristo valmistajan ohjeiden mukaisesti.

VORSICHT!

Explosionsgefahr bei unsachgemäßen Austausch der Batterie Ersatz nur durch denselben oder einem vom Hersteller empfohlenem ähnlichen Typ. Entsorgung gebrauchter Batterien nach Angaben des Herstellers.



Overview	3
Processors	3
Memory	4
System chipsets	4
Server Works LE north and south bridge	4
SCSI subsystem	4
LAN subsystem	5
Video subsystem	5
Expansion slot	5
Hardware management support	5
Features summary	7
Weight	8
Checking the package contents	9
System startup	10
Power-on problems	11
Basic connections	12
Connecting the keyboard	12
Connecting the mouse	12
Connecting the VGA monitor	13
Connecting the power cable	13
External and internal structure	17
Front panel	17
Rear panel	19
Internal components	20
System board layout	21
LED/switchboard connector (CN15)	23
Disk drives	24
3.5-inch floppy disk drive	24
CD-ROM drive	24
To insert a CD into your system's CD-ROM drive:	25
To take care of your CDs:	25
ESD precautions	29
Server rack installation	30
Vertical mounting hole pattern	30
Installing cage nuts	31
Installing the system into the rack	31
Opening the housing panel	39
Installing an expansion board	40
Hot-swapping SCSI SCA hard disk drive	42
Installing and removing the CPU	44
Installing a CPU	44
Removing a CPU	45
Installing and removing memory modules	47

Contents

Reconfiguring the system	48
Introduction	51
Entering Setup	52
System information	54
Product information	56
Disk drives	57
IDE channel type	59
Onboard peripherals	62
Power management	66
Boot options	69
Date and time	72
System security	73
Supervisor password	73
Setting and changing a password	73
Removing a password	75
Bypassing a supervisor password	75
User password	76
Disk drive control	76
Floppy drive and hard disk drive	77
Processor serial number	77
IPMI configuration	78
RDM configuration	80
Advanced options	84
Memory/Cache options	85
PnP/PCI options	86
CPU Frequency	89
Load default settings	91
Abort settings change	92
Exit Setup	93
Installing ASM Pro	97
System requirements	97
ASM Console	97
ASM Server and Desktop agents	97
System setup	97
Installing ASM Console	98
Installing ASM Server Agent	98
Installing the Novell NetWare Server Agent	98
Installing the SCO OpenServer Agent	101
Installing the SCO UnixWare Server Agent	102
Installing the Microsoft Windows NT Server Agent	103
Installing RDM	105
System requirements	105
RDM server requirements	105

RDM Manager Station requirements	105
RDM server setup	106
Installing RDM module	106
Connecting communication peripherals	107
Installing RDM agent software	108
Installing AWM and Microsoft IIS	112
System requirements	112
Installing AWM	112
Setting up Microsoft IIS	112

1 Getting started

The Acer Altos 1200LP is a 1U, high density, rackmountable dual-processor system loaded with a host of new and innovative features. The system offers a new standard for flexible productivity ideal for local or wide area networks and multiuser server environments.

Overview

The Acer Altos 1200LP system is a PCI bus based dual processor system built on an extended ATX baseboard. It comes with two socket 370 processor slots utilizing two Intel® Pentium® III processors integrated with the Server Works LE north and OSB4 south bridge chipsets. The dual channel SCSI architecture supports Ultra 160/m SCSI with bandwidth of up to 160 MB/s for each channel. The system board also integrates the Intel® 82559 10/100 Mbps PCI Ethernet chipset that supports WOL (Wake on LAN) function for better remote site management.

For expandability, the system includes one 64-bit/66 MHz PCI bus slot and four DIMM slots that allows memory installation to a maximum of 2-GB using four 512-MB SDRAM (Synchronous DRAM).

For connectivity, the system supports four USB (Universal Serial Bus) connector, a video port, two LAN ports, and other standard features such as two UART NS16C550 serial ports, one enhanced parallel port with Enhanced Parallel Port (EPP)/Extended Capabilities Port (ECP) feature, a diskette drive interface, and two embedded hard disk interfaces.

The system is fully compatible with MS-DOS V6.X, Novell Netware, Novell, SCO UNIX Openserver, SCO Unixware, Linux, Sun Solaris, Windows 95/98, Windows NT 4.0, and Windows 2000.

Processors

The Pentium III processor implements Dynamic Execution performance, a multi-transaction system bus, and Intel MMX media enhancement technology. Also, it offers Streaming SIMD (Single Instruction Multiple Data) Extensions - 70 new instructions enabling advanced imaging, 3D, streaming audio and video, and speech recognition applications. The Pentium III processor delivers higher performance than the previous Pentium processor while maintaining binary compatibility with all previous Intel Architecture processors.

This system board supports 100 or 133 MHz GTL+ host bus frequencies for Pentium III processors running at 800 MHz and above.

Memory

The four DIMM sockets on board allow memory upgrade to a maximum of 2-GB using four 512-MB SDRAM (Synchronous DRAM) DIMMs. For data integrity, the default setting of the ECC (Error-Correcting Code) function of the memory system in BIOS is enabled.



Note: The SDRAM should work under 3.3-volt only; 5-volt memory devices are not supported.

The system board supports both 100 and 133 MHz registered SDRAMs only; 66 MHz SDRAMs are not supported.

System chipsets

Server Works LE north and south bridge

The Server Works LE north chipset incorporated as a north bridge is in charge of the host bus interfacing and memory bus control. The memory bus control supports two and four way interleaved of PC-100 and PC-133 SDRAM registered ECC DIMM up to 4GB. The north bridge provides one 64-bit PCI bus running at 66 MHz.

The south bridge subset provides the legacy ISA interface, USB port, ATA33, and SM bus. The BMC (Baseboard Management Control) was embedded on the motherboard and connected with the south bridge to provide the ASM and RDM function and also industry standard IPMI protocol as well.

SCSI subsystem

The dual-channel AIC-7899 single-chip host adapter delivers Ultra160 SCSI data transfer rates which doubles Ultra-2 SCSI data transfer rate of up to 160 MByte/sec. With two channels, it delivers a total of 320 MByte/sec bandwidth. In addition, the AIC-7899 features a 66 MHz, 64-bit PCI interface that supports zero wait-state memory which also operates on 33 MHz, 32-bit PCI buses. It supports up to 15 devices on a 12 meter

cable (or 25 meters in a point-to-point configuration), making them ideal for clustering and RAID configurations.

LAN subsystem

Another cost-effective feature for network solution is the integration of Intel's 82559 10/100 Mbps Fast Ethernet controller which supports Advanced Configuration and Power Interface (ACPI) 1.20A based power management, wake on Magic Packet*, wake on interesting packet, advanced System Management Bus (SMB) based manageability, Wired for Management (WfM) 2.0 compliance, IP checksum assist, PCI 2.2 compliance, PC 98, and PC 99 compliance.

Video subsystem

The ATI Rage XL harbors 2D and 3D display capabilities that brings life to any multimedia and work applications. It also supports hardware DVD decoding. With a remarkable color depths and high resolutions of up to 1600x1200 for an enhanced visual experience on your system.

The on board ATI Rage XL chipset comes with 4 MB of video memory and supports up to 1024x768 display mode at high colors with a maximum of 4 MB video memory option.

Expansion slot

The system board has one 64-bit/66 MHz PCI bus slot with a riser card.

Hardware management support

The system supports the power-management function that conforms to the power-saving standards of the U.S. Environmental Protection Agency (EPA) Energy Star program. It also offers the Plug-and-Play feature. This feature saves the user from configuration troubles, thus making the system more user-friendly.

Additional features includes hardware support for ASM (Advanced Server Manager) and RDM (Remote Diagnostic Management). ASM detects problems in CPU thermal condition, CPU working voltage detection ($\pm 12V/\pm 5V/3.3V/1.5V/1.8V$), and PCI bus utilization calculation. It also

detects if the CPU fan or the chassis fan malfunctions while RDM allows execution of the RDM diagnostic program from a remote RDM station to fix detected problems or to reboot the system.

► Features summary

The system has the following major components:

- Utilizes a FC-PGA (Flip-Chip Pin Grid Array) processor socket that supports a Pentium III processor running at 600/133 to 800/133 MHz and future generations of Pentium CPUs
- Server Works LE chipset which includes the north and south bridge and BIOS
- SCSI controller chipset Adaptec® AIC-7899 supports dual channel 64-bit LVD Ultra 160/m devices connection in 64-bit/66 MHz PCI bus:
 - Channel A- one 68-pin Ultra160 SCSI connector
 - Channel B- one 68-pin Ultra160 SCSI connectors
- Onboard 10/100 Mb/s Intel 82559 LAN chip that supports WOL
- Four DIMM sockets that accept 128-, 256-, and 512-MB SDRAMs with a maximum memory upgrade of 2-GB (also supports 1024-MB for a maximum upgrade of 4-GB in future models)
- One 64-bit/66 MHz PCI slot
- PCI SVGA on-board supports analog CRT monitors. Supports up to 1024x768 resolution with on-board VGA SDRAM RAM
- System clock/calendar with battery backup
- IDE hard disk and diskette drive interfaces
- Auxiliary power connector for ATX power supply
- Super I/O, Advanced Server Management (ASM) and Remote Diagnostic Management (RDM) controller chipsets
- External ports:
 - USB connectors
 - PS/2-compatible keyboard port
 - PS/2-compatible mouse port
 - Serial port
 - Two RJ-45 jacks
 - Video port
 - Parallel port

Weight

The table below lists the weight of individual components used in deployment of this system in third-party racks.

Item	Weight in Kg	Weight in lbs
Fully configured system	11 Kg	24.2 lbs
Rack mount kit	3.5 Kg	9.7 lbs
CPU and fan sink	0.24 Kg	0.53 lbs
Hard disk drive	0.65 Kg	1.43 lbs
Power supply module	1.3 Kg	2.86 lbs
Floppy disk drive	0.16 Kg	0.35 lbs
PCI card	0.04 ~ 0.4 Kg	0.09 ~ 0.88 lbs

Checking the package contents

Check the following items from the package:

- Acer Altos 1200LP system
- Acer Altos 1200LP User's guide
- CD-ROM driver kits
- One front bezel for rackmount installation
- Two additional CPU fansink

If any of the above items are damaged or missing, contact your dealer immediately.

Save the boxes and packing materials for future use.

System startup

After making sure that you have set up the system properly and connected all the required cables, you may now apply power to the system.

To power on the system, press the On/Off button.

The system starts up and displays a welcome message. After that, a series of power-on self-test (POST) messages appears. The POST messages indicate if the system is running well or not.



.....

Note: If the system does not turn on or boot after pressing the On/Off button, go to the next section for the possible causes of the boot failure.

Aside from the self-test messages, you can determine if the system is in good condition by checking if the following occurred:

- Power indicator LED on the front bezel lights up (green)
- Power, Num Lock, and Caps Lock LED indicators on the keyboard light up

▶ Power-on problems

If the system does not boot after you have applied power, check the following factors that might have caused the boot failure.

- The external power cable may be loosely connected.
Check the power cable connection from the power source to the power socket on the rear panel. Make sure that each cable is properly connected to each power supply.
- No power comes from the grounded power outlet.
Have an electrician check your power outlet.
- Loose or improperly connected internal power cables.

If you are not confident to perform this step, ask a qualified technician to help you.



.....
Warning! Make sure all power cords are disconnected from the electrical outlet before performing this task.



.....
Note: If you have gone through the preceding actions and the system still fails to boot, ask your dealer or a qualified technician for assistance.

Basic connections

The system unit, keyboard, mouse, network connection, and monitor constitute the basic system. Before connecting any other peripherals, connect these peripherals first to test if the basic system is running properly.

Connecting the keyboard

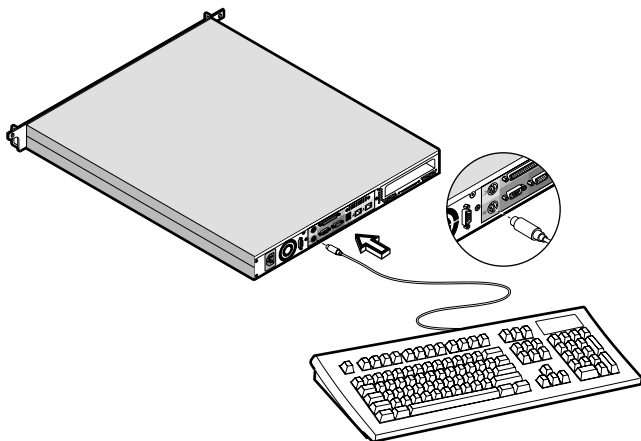

Connecting the mouse

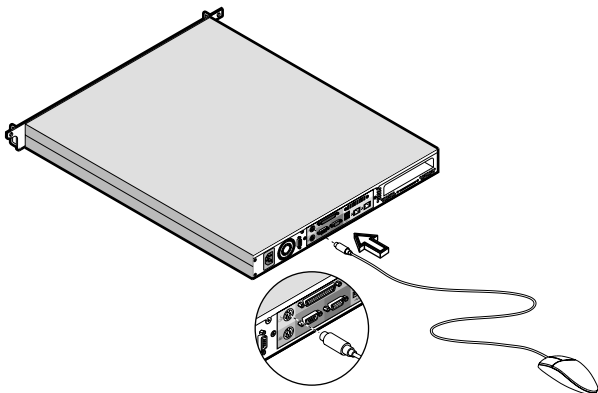

Connecting the VGA monitor

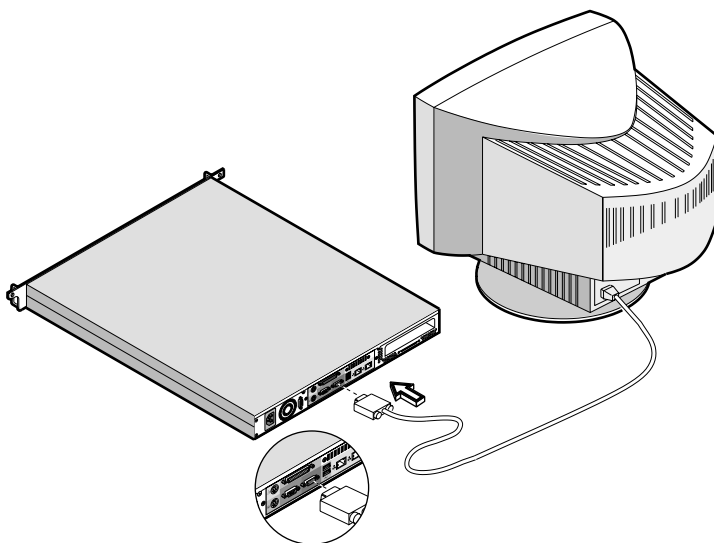

Connecting the power cable

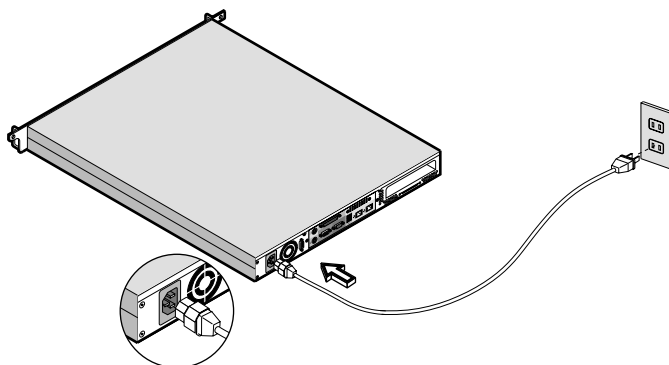

2 System tour







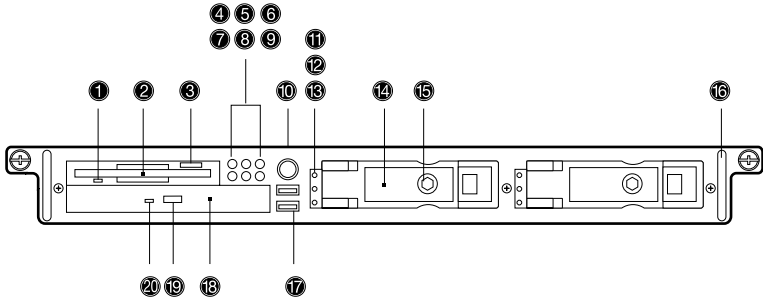

This chapter discusses the features and components of your computer.

► External and internal structure

Front panel



No.	Icon	Item
1		Slim type floppy disk drive LED
2		Slim type floppy disk drive
3		Slim type floppy disk drive eject button
4	!	Event LED
5		Hard disk drive access LED
6		Power LED
7		LAN 2 access LED
8		LAN 1 access LED
9		Reserved

No.	Icon	Item
10		Power switch
11		Hard drive power LED
12		Hard drive activity LED
13		Hard drive error LED
14		Drive trays
15		Drive tray lock
16		Metal handle
17		USB ports (2 ports)
18		Slim type CD-ROM drive emergency eject hole
19		Slim type CD-ROM drive eject button
20		Slim type CD-ROM drive LED

Rear panel

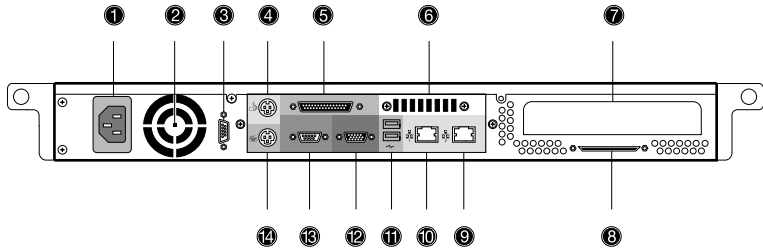

No.	Item
1	Power supply
2	Power supply fan
3	Serial port 2
4	PS/2 mouse port
5	Parallel port
6	Ventilation
7	Add-on card bracket
8	Very high density SCSI connector
9	LAN 2 port (RJ-45)
10	LAN 1 port (RJ-45)
11	USB ports
12	VGA port
13	Serial 2 port
14	PS/2 keyboard port

Internal components

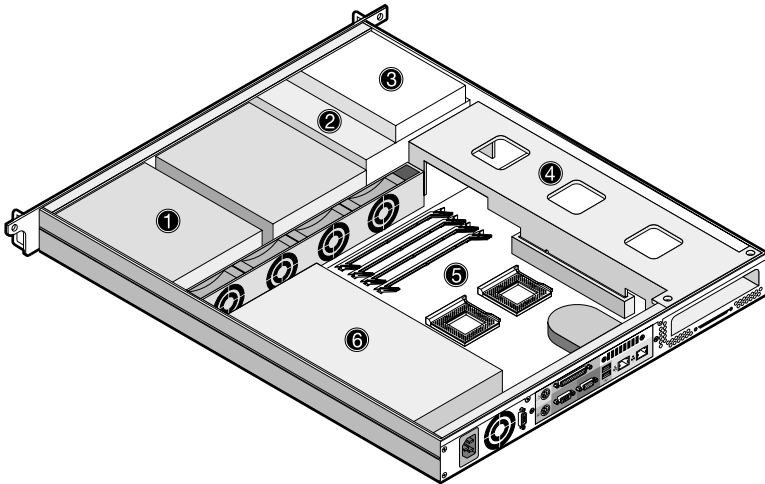

No.	Item
1	Hot-swap SCSI hard disk drive trays
2	Slim type CD-ROM drive
3	Slim type floppy disk drive
4	Metal bracket/Expansion card slot
5	System board
6	Power supply
7	Housing fans

System board layout

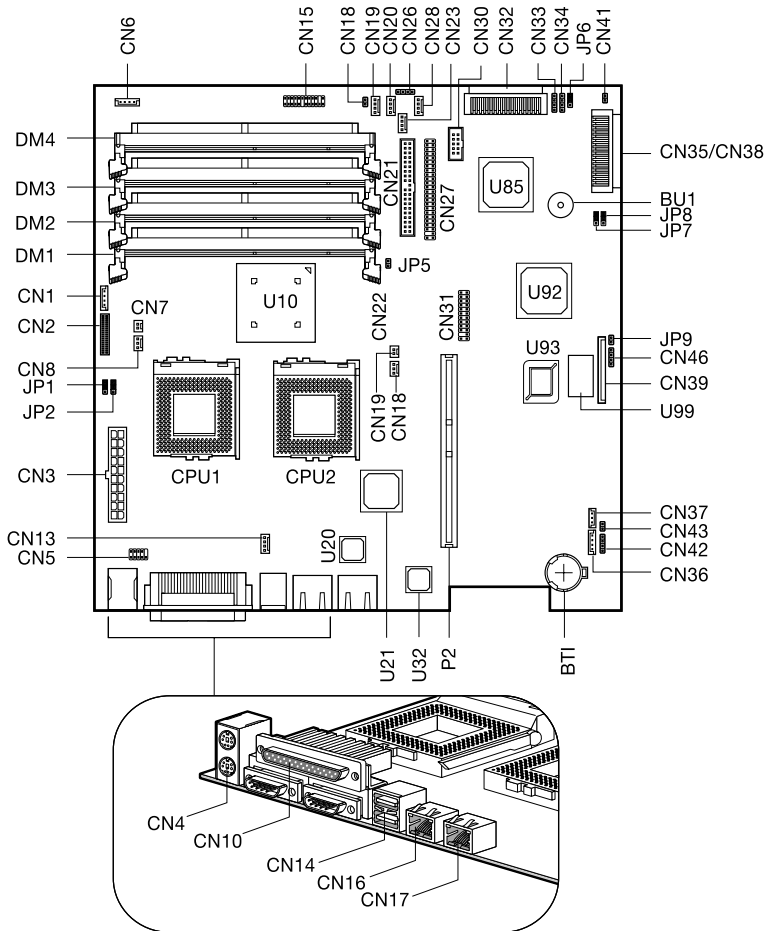

Item	Description
BT1	Battery
BU1	Buzzer
CN1/CN6/ CN36	IPMI connector
CN2	ITP port

Item	Description
CN3	ATX power supply connector
CN4	Upper: PS/2 mouse connector Lower: PS/2 keyboard connector
CN5	Serial port connector
CN7	CPU 1 thermal connector
CN8	CPU 1 fan connector
CN10	Upper: Parallel port Lower left: Serial 1 port Lower right: VGA port
CN13	Housing fan connector
CN14	USB1 and 2 connector
CN15	LED/Switchboard connector (see page 23)
CN16	LAN1 Jack (RJ45)
CN17	LAN2 jack (RJ45)
CN18	NMI switch
CN21	Primary IDE connector
CN22/CN31	BMC DB connector
CN25	CPU 2 thermal connector
CN26	LAN1/LAN2 status report connector
CN27	Slim-type CR-ROM connector
CN30	USB connector
CN32	Wide SCSI channel B connector
CN33/CN34	External hard disk drive LED connector
CN35/CN38	Wide SCSI channel A connector
CN37	Wake on LAN connector
CN39	Slim-type FDD connector
CN42	1 ² C connector
CN43	IOCHRDY (for debug)
CN45	BPL1 fail LED
CPU1	CPU Slot 1slot
CPU2	CPU Slot 2 slot
DM1 to DM4	DIMM slots
JP4	Power LED connector, Reset switch connector
JP5	Event clear connector
JP6	SCSI terminator 1-2: Disabled 2-3: On

Item	Description
JP8	Password settings 1-2 : Check password 2-3 : Bypass password
JP9	Speaker connector
P2	64-bit/66 MHz PCI slot
U10	Server Works LE north bridge
U20	Intel 82559 LAN1 chipset
U21	ATI Rage XL video chipset
U32	Intel 82559 LAN2 chipset
U66	Adaptec AIC-7899 chipset
U92	Server Works LE south bridge (OSB4)
U93	BIOS chipset
U99	SMC 47B277 supoer I/O chipset

LED/switchboard connector (CN15)

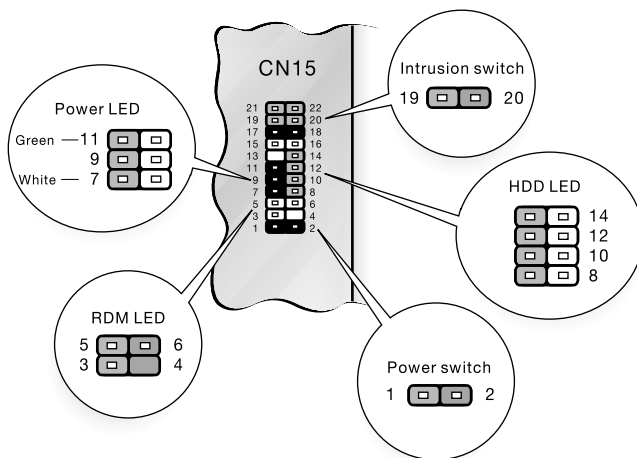

► Disk drives

Your system comes with the following disk drives:

3.5-inch floppy disk drive

Your system's 3.5-inch floppy disk drive can handle 720-KB and 1.44-MB capacity diskettes.

The floppy diskettes are compact, lightweight, and easy to carry around. Here are some tips on how to take care of your diskettes:

- Always make backup copies of the diskettes that contain important data or program files.
- Keep diskettes away from magnetic fields and sources of heat.
- Avoid removing a diskette from a drive when the floppy drive activity light is on.
- Write-protect your diskettes to prevent accidental erasure. To do this, slide the write-protect tab to the write-protect position.

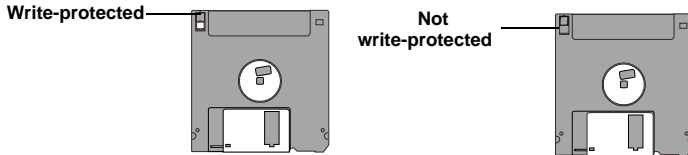

- When you put a label on a 3.5-inch diskette, make sure that the label is properly attached (flat on the surface) and within the labeling area (area with a slight surface depression) on the diskette. An improperly attached label may cause a diskette to get stuck in a drive when you are inserting or removing it.

CD-ROM drive

Your system comes with a CD-ROM drive. This drive is located on the front panel of your system. The CD-ROM drive allows you to play different types of Compact Discs (CDs) and video CDs. CDs, like diskettes, are also compact, lightweight, and easy to carry around.

However, they are more delicate than diskettes and must be handled with extra care.

To insert a CD into your system's CD-ROM drive:

1. Gently push the eject button located on the front panel.
2. When the disc tray slides open insert the CD. Make sure that the label or title side of the disc is facing upward.



.....

Caution! Hold the disc by the edges to avoid leaving smudges or fingerprints.

3. Push the eject button again to close the tray.

To take care of your CDs:

- Keep your discs in a disk case when not in use to avoid scratches or other damage. Any kind of dirt or damage can affect the data on the disc, impair the disc lens reader on the CD-ROM drive, or stop the system from successfully reading the disc.
- When handling discs, always hold them by the edges to avoid smudges or fingerprints.
- When cleaning discs, use a clean, dust-free cloth and wipe in a straight line from the center to the edge. Do not wipe in a circular motion.
- Clean your CD-ROM drive periodically. You may refer to the Cleaning Kit for instructions. Cleaning Kits can be purchased in any system or electronics shop.

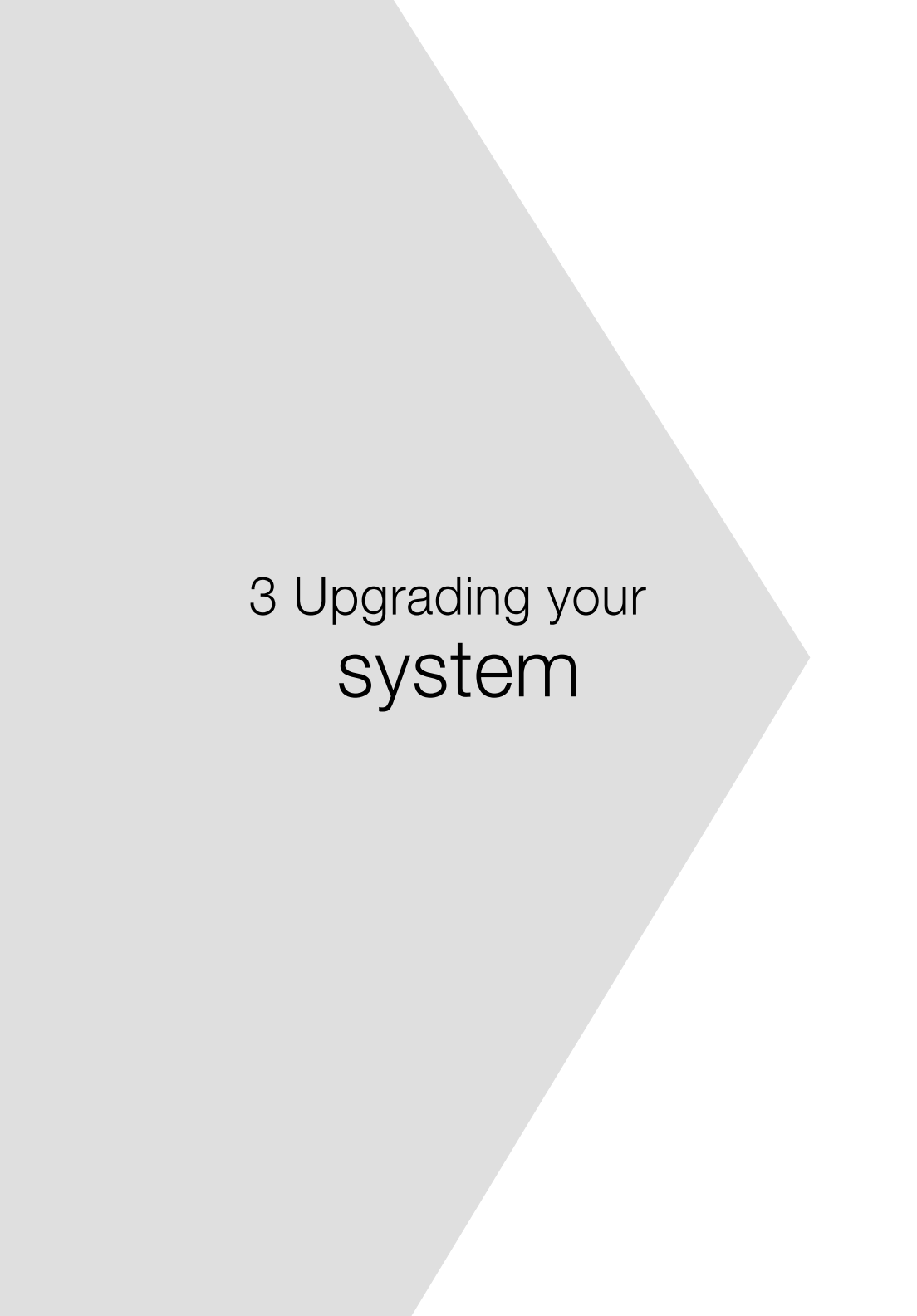

3 Upgrading your system

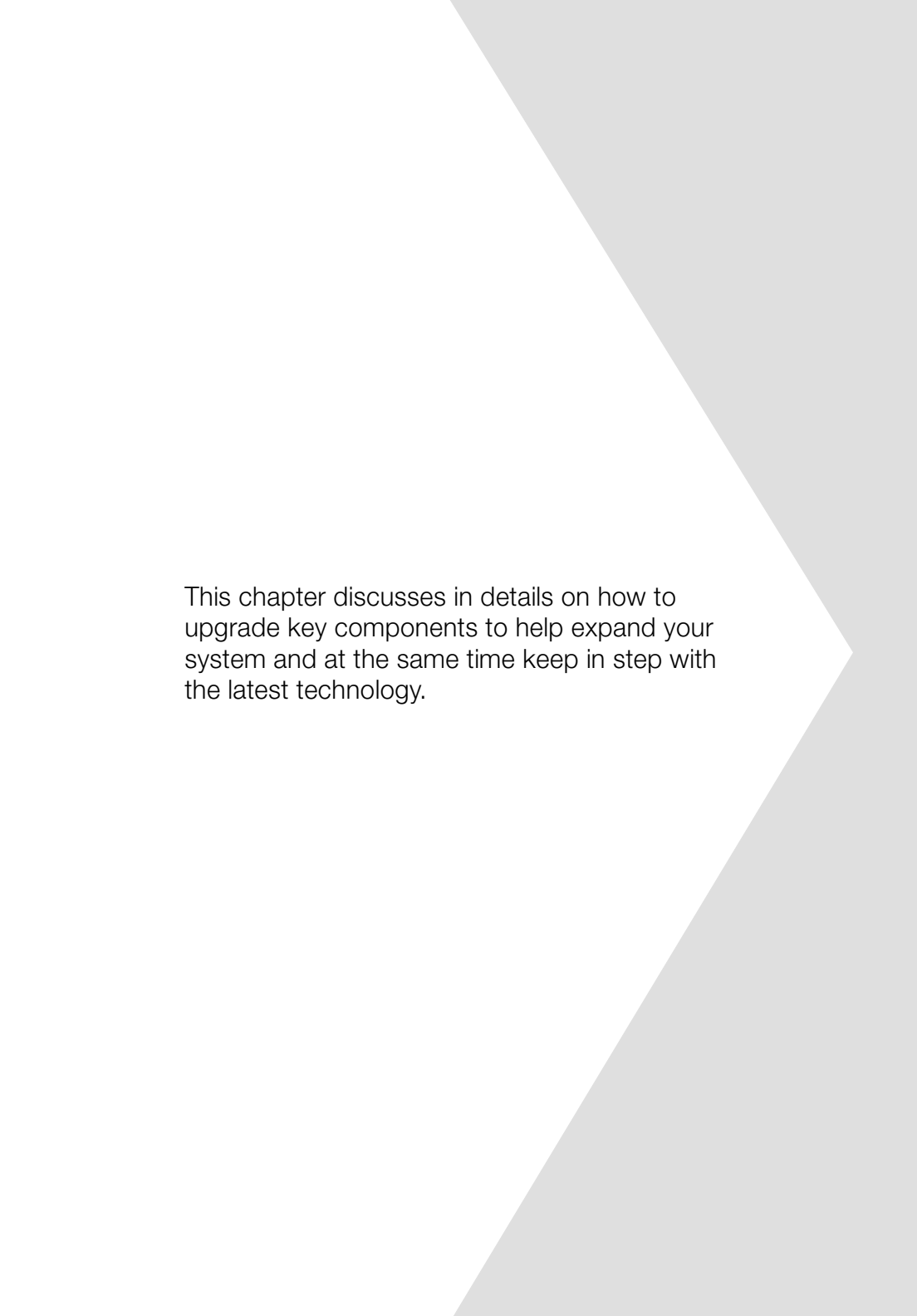

This chapter discusses in details on how to upgrade key components to help expand your system and at the same time keep in step with the latest technology.

► ESD precautions

Always observe the following electrostatic discharge (ESD) precautions before installing a system component:

1. Do not remove a component from its antistatic packaging until you are ready to install it.
2. Wear a wrist grounding strap before handling electronic components. Wrist grounding straps are available at most electronic component stores.



.....

Note: Do not attempt the procedures described in the following sections unless you are a qualified technician.

► Server rack installation

Vertical mounting hole pattern

The four vertical rails of a rack contain mounting holes arranged in a manner shown in this figure:

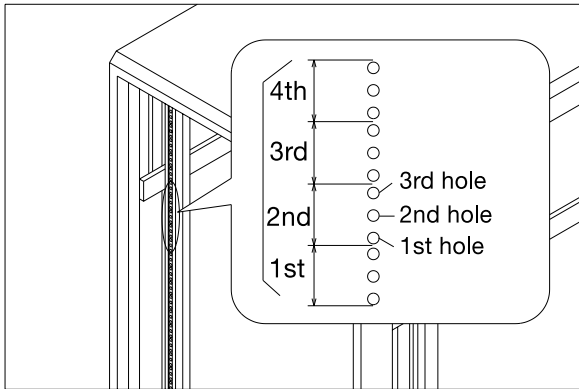

The system occupies 1U in the rack. Count the U positions and hole numbers from the bottom up.



Note: The unit of measurement used in this document is "U" (1U = 1.75 inches or 44.45 mm). The total sum of the heights of all components in the rack measured in "U" cannot exceed the height of the rack. For more information, please refer to the rack's documentation.

The distance from the center of two holes with closer spacing to the center of the next pair is equivalent to 1U.

When installing components, you must start your measurement from the center of the two holes with closer spacing. Otherwise, the screw holes on the component may not match with those on the rack.

Installing cage nuts

Cage nuts are used to secure systems and other components to the vertical rails in the rack.

To install cage nuts:

1. Insert the lower lip of the cage nut over the bottom of the opening at the back of a rail.
2. Insert the small end of the cage-nut installation tool through the opening in front of the rail and hook the tool over the top lip of the cage nut as shown below.
3. Push in the cage nut while rotating the tool up and pulling the tool back toward you until the top lip of the cage nut snaps into position.
4. Repeat this process to install the other cage nuts in the appropriate locations.

Installing the system into the rack

To install the system into the rack:

The rails allow the system to slide in and out of the rackmount for maintenance purposes. Follow these steps to install the mounting rails:

1. Extend the component rail (a) from the mounting rail (b) until the component rail release latch clicks. Hold down the latch and slip the component rail out of the mounting rail. Do the same thing to the other mounting rail.



Note: Each mounting rail consists of a fixed outer piece that screws onto the mounting bracket and an inner sliding piece controlled by a

steel ball gearing movement. This inner sliding piece is not detachable.

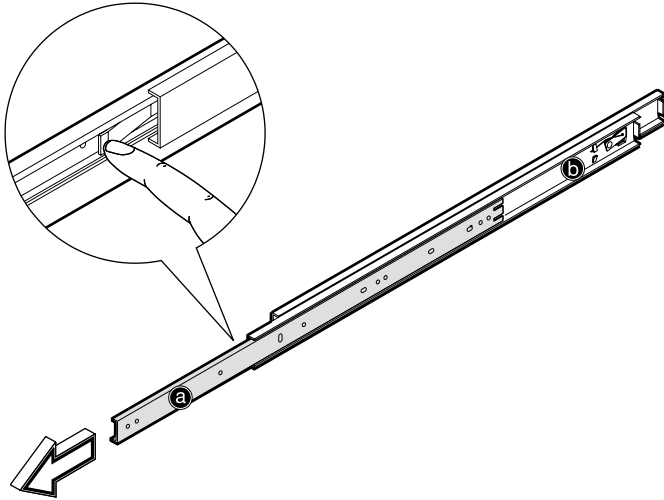

2. Put the component rails aside.
3. Attach the mounting brackets to the mounting rails.

The mounting brackets consists of two metal bars to be attached on both ends of the mounting rails.

- a. Attach the mounting bracket to the front end of the mounting rail and align the screw holes.



.....

Note: Look for an imprint that says front or rear on the mounting bracket. Install the mounting bracket on the appropriate side, otherwise, it will not fit correctly into the rack.

- b. Secure it with three M4x8L screws with nut and washer as shown below. Slide and adjust the inner piece of the mounting rail to

gain access to the screw holes. The position of the mounting bracket on this end is fixed.

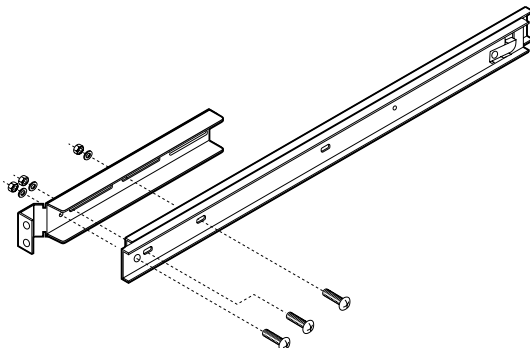

- c. Extend the inner sliding piece of the mounting rail until you can see the screw holes on the other end. Attach the mounting bracket to the rear end and secure it with two screws. The mounting rail on this end is adjustable.

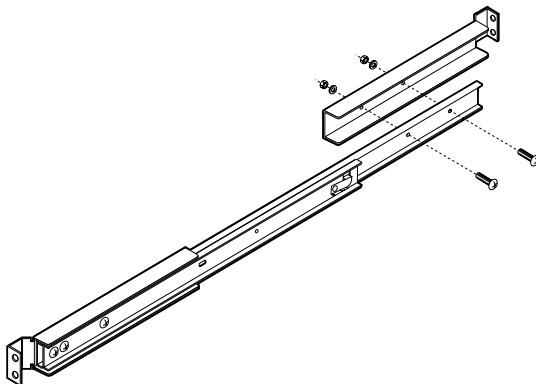

4. Attach the mounting brackets and the cable carrier to the rack with nine M6 screws.
- a. Install the left mounting bracket first using four M6 screws.



.....

Note: The system occupies 1U. Count the U positions and hole numbers from the bottom up. Secure the mounting bracket on the 1st and the 2nd holes of the 1st U using four M6 screws. Make sure that both of the mounting brackets are at the same level. Take note of

the vertical rail hole pattern. See “Vertical mounting hole pattern” on page 30.

- b. Install the right mounting bracket with the cable carrier using five M6 screws. The cable carrier is installed on the rear as shown below.

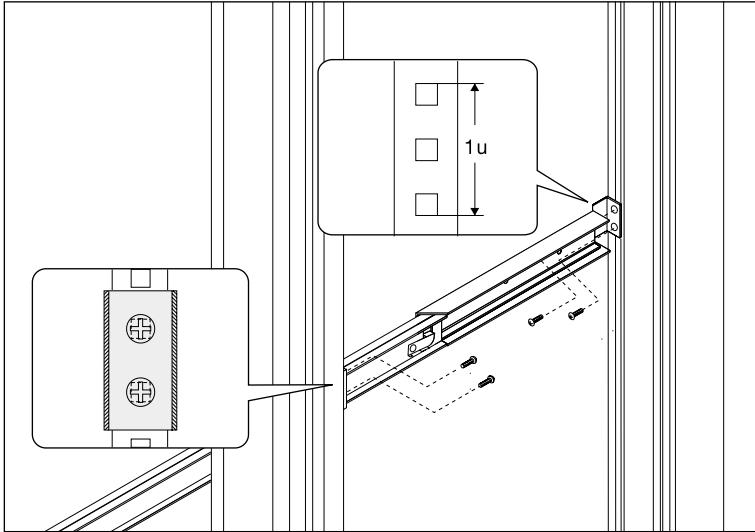

Note: The cable carrier allows you to tie-wrap all cables to and from the server. As you slide the system in and out of the rack, the cable carrier collapses and extends, keeping the cables untangled and attached to the system.

5. Secure the front panel to the system with three M3 screws.

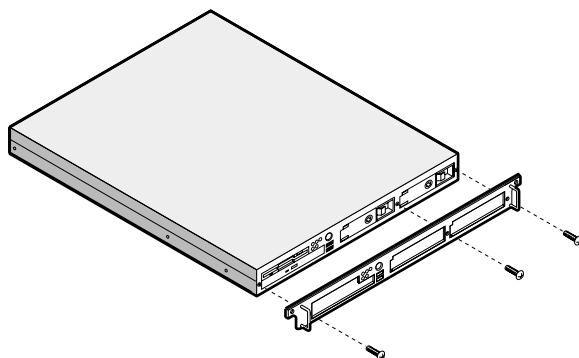

6. Attach the component rails to the system with eight M4x5L screws.

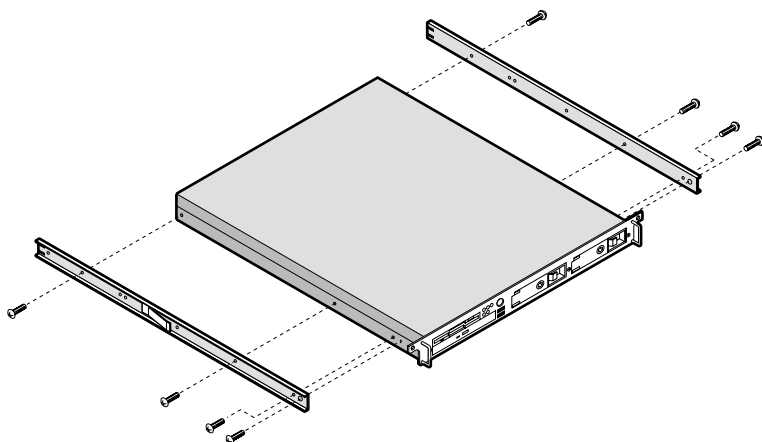

7. Extend the inner sliding piece of the mounting bracket.

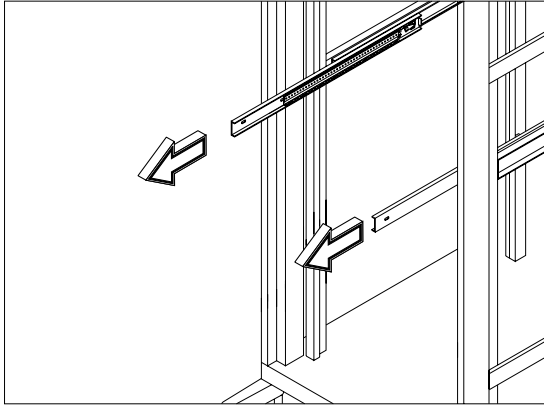

8. Slide the system into the rack.

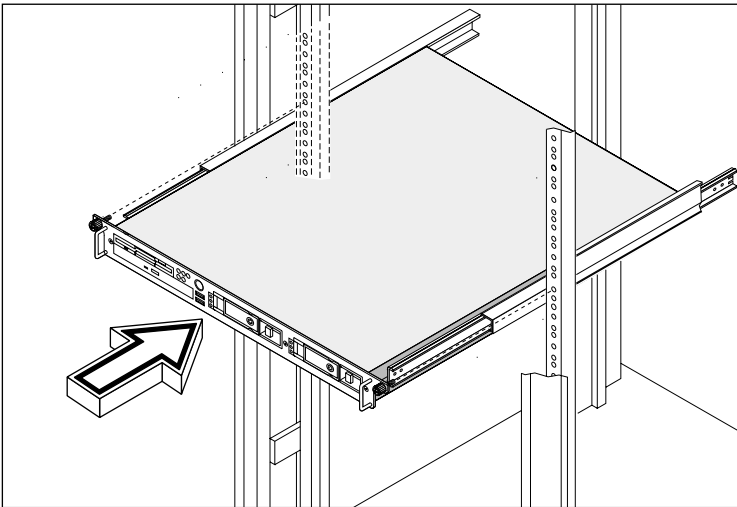

9. Attach the cable carrier arm bracket to the rear of the system using two #6-32 screws. See next figure.

10. Attach cable carrier to the cable carrier arm bracket using three #6-32 screws.

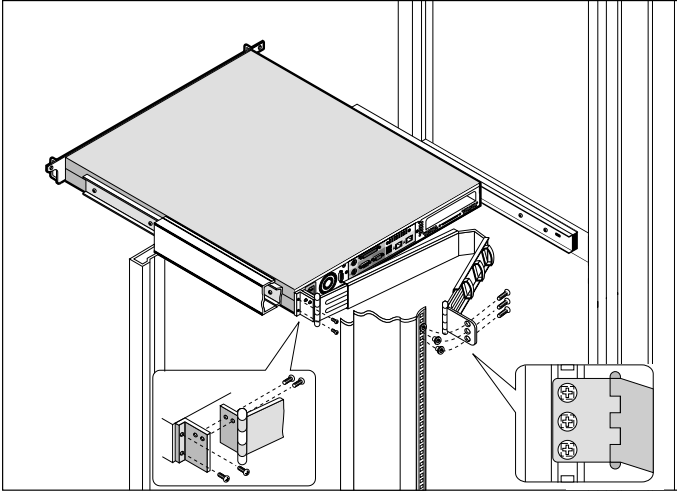

11. Pull out the system to extend the cable carrier. Bundle all cables to the cable carrier with the cable straps. Route all cables from the cable carrier to the cable management bracket located on the rear of the rack.

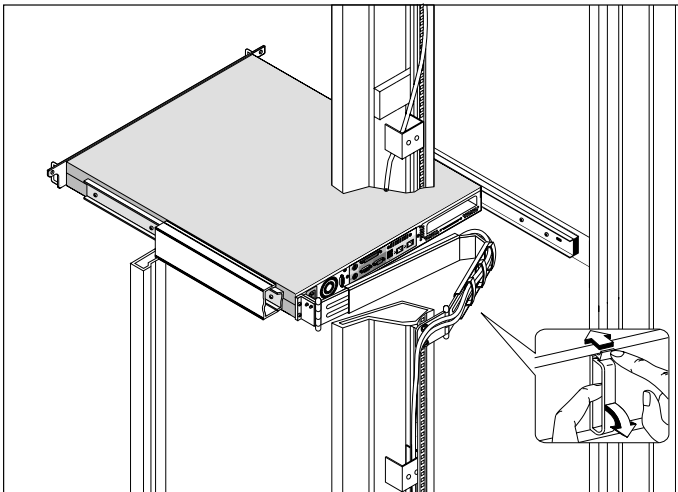

12. Install two cage nuts (see page 31) and secure the system to the rack using two M6 screws.

▶ Opening the housing panel

Always observe the following ESD (electrostatic discharge) precautions before installing any system component:

1. Do not remove any system component from its packaging unless you are ready to install it.
2. Wear an antistatic strap before handling electronic components. Antistatic straps are available at most electronic component stores.



.....
Warning! DO NOT attempt the procedures in the following sections unless you are confident of your capability to perform them. Otherwise, ask a service technician for assistance.

A microswitch is allocated on the housing panel. It helps indicate whether the panel is removed or intact.

To remove the housing panel:

1. Turn off the power to the system unit and unplug all cables.
2. Unlock two thumbscrews using your fingers.
3. Gently pull back the housing panel and detach.

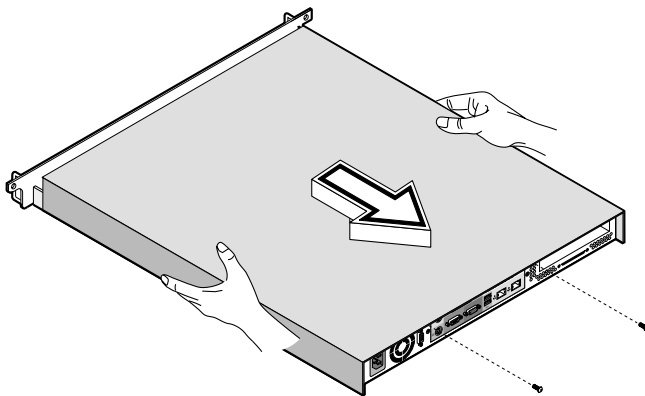

▶ Installing an expansion board

To install an expansion board:

1. Open the housing panel. See “Opening the housing panel” on page 39 for more information.
2. Remove the metal bracket from the housing by removing two screws. Save the screws for later use.
3. Gently pull out the metal bracket with the riser card from the system board.

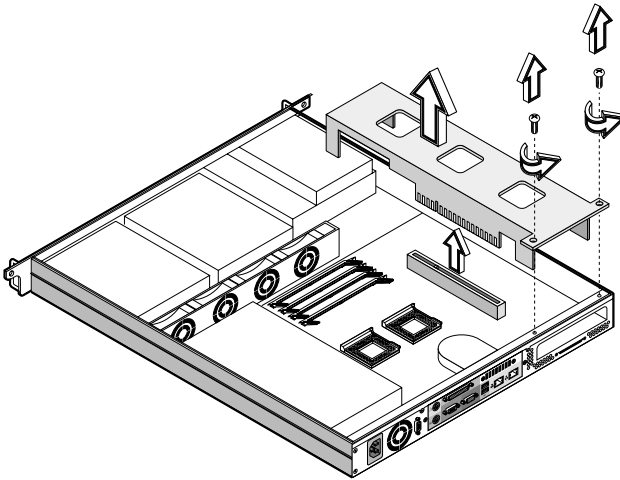

4. Remove the expansion slot bracket. Save the screw for later use.

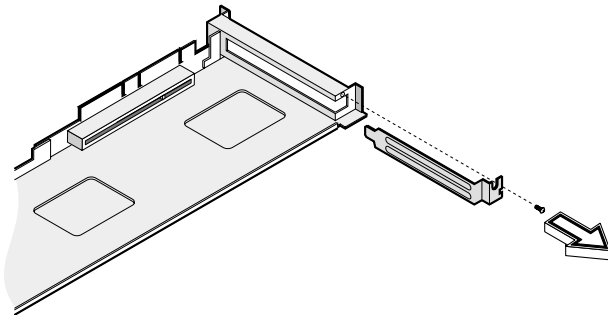

5. Insert the expansion card into the riser card.
6. Secure the expansion board to the metal bracket with a screw.

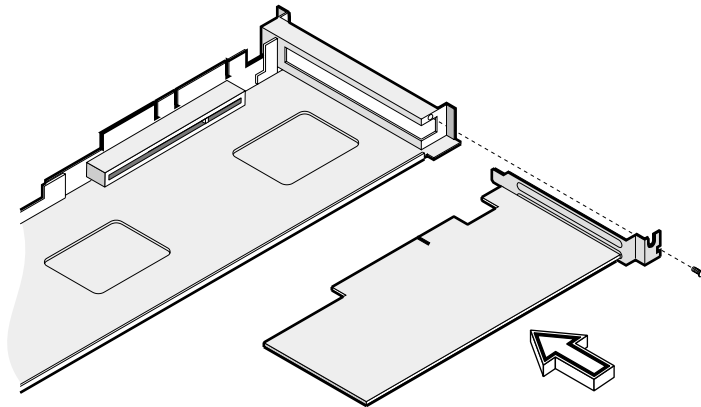

7. Reinstall the metal bracket with the riser card into the system board and secure it with two screws.

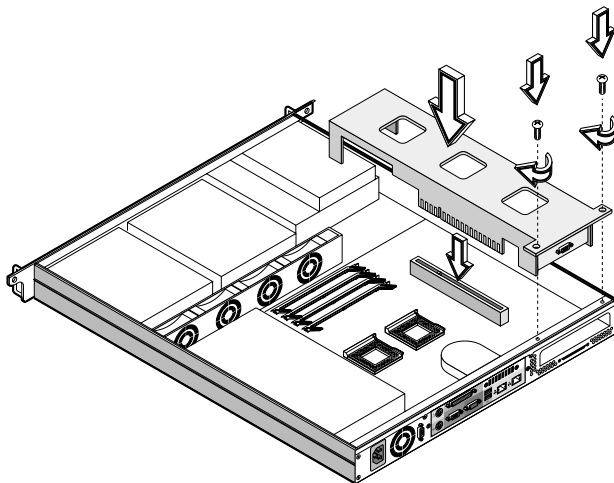

8. Reinstall the housing panel.

► Hot-swapping SCSI SCA hard disk drive

You can hot-swap (remove and replace) a hard disk drive any time when it fails to operate (indicated by the yellow LED).



Warning! Do not remove a hard disk drive when active. This may cause undue damage to the hard disk drive.

Follow these steps to install a hot-swappable SCSI drive:

1. Unlock the drive tray with a hex key.
2. Use your finger to release the drive tray and then pull it out.

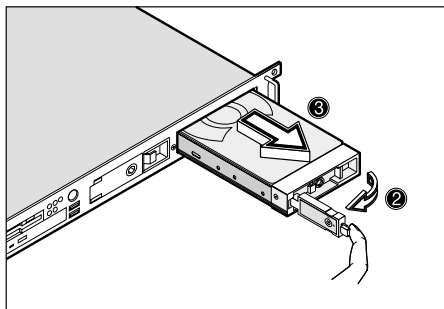
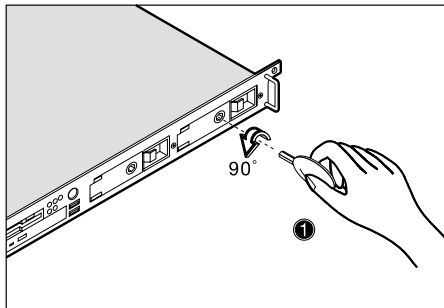

3. Place a hard disk on the tray. Secure it with four screws as shown below.

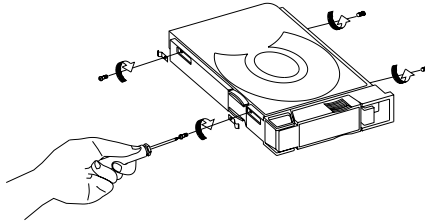

4. Insert the tray into the hot-swap cage with the lever still extended. Make sure that the drive is properly inserted before closing the lever.

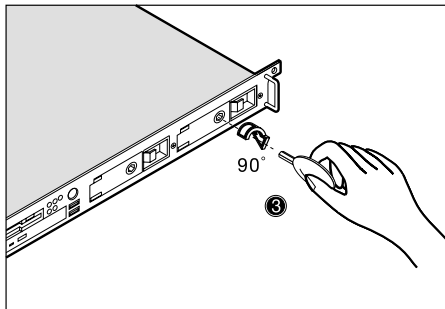
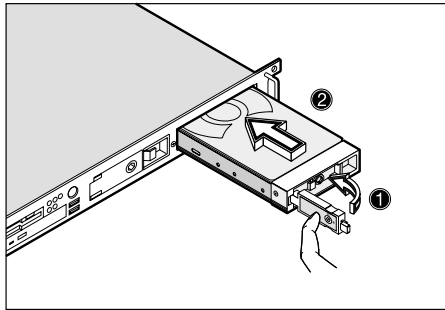

5. Push the lever back until it clicks into place.

▶ Installing and removing the CPU

The Pentium III comes in a FC-PGA (Flip-Chip Pin Grid Array) 370 pin package. The FC-PGA package is designed for the new breed of sleek, high performance, small form factor PCs.

The system board supports a Pentium III processor running at 600/133 to 866/133 MHz, and future generations of Pentium CPUs.



.....

Caution: Always observe the ESD precautions when installing or removing a system component. Refer to the section above.

Installing a CPU

Follow these steps to install a CPU:

1. Remove the processor from its protective packaging.
2. Insert the new CPU into the CPU socket (a and b). Make sure that pin 1 (indicated by a notched corner) of the CPU connects to hole 1 of the socket.

Push down the socket lever to lock the new CPU into the socket (c).



.....

Note: You need to install a terminator board into the CPU 2 socket if you only install one CPU (must be installed in the CPU 1 socket). Also, change JP10 to On if you install a terminator board into the CPU 2 socket (see xx).

3. Attach one side of the fan/heatsink metal bracket to the CPU socket (e) and then gently push down the other side of the metal bracket (f) until it locks in place (g).

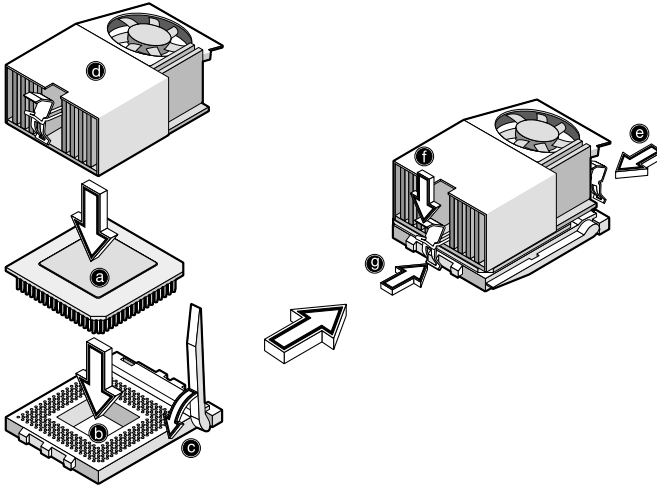

4. Connect the 3-pin and 2-pin fan/heatsink cables to the system board. Refer to “System board layout” on page 21 for the location of the fan/heatsink connectors.



.....

Caution: The heatsink becomes very hot when the system is on.
NEVER touch the heatsink with any metal or with your hands.

Removing a CPU

Follow these steps to remove a CPU:

1. Disconnect the 3-pin and 2-pin fan/heatsink cables from the system board.
2. Release the fan/heatsink metal bracket by pressing the hook (a). Unhook one side of the fan/heatsink metal bracket (b) and gently lift it before removing the other side (c and d).

3. Push the socket lever down to release the lever (e) and then carefully remove the CPU (f).

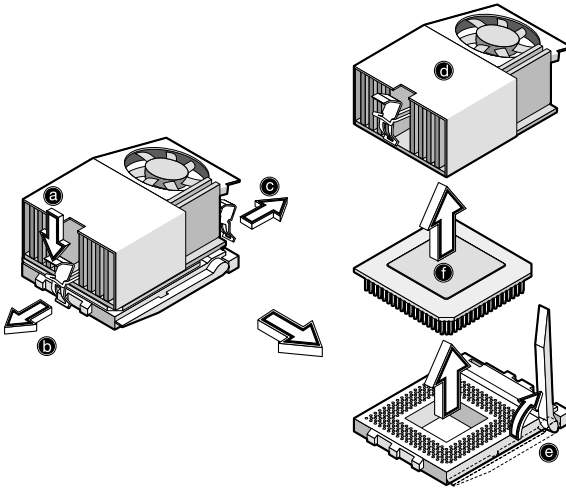

▶ Installing and removing memory modules

The four 168-pin sockets on board support SDRAM-type DIMMs. You may install 128-MB, 256-MB, 512-, or 1024-MB (single and double density) DIMMs for a maximum of 4-GB system memory.



Note: The SDRAM should work under 3.3 volts only; 5-volt memory devices are not supported.

This system board supports 100 and 133 MHz SDRAM. However, they cannot be used at the same time in the system.



WARNING! Do not use both 100 MHz and 133 MHz SDRAM together. This might cause your system to malfunction. For a list of qualified DIMM vendors, please contact your reseller.

Each of the DIMM sockets is independent from the others. This independence allows you to install DIMMs with different capacities to form different configurations.

To install a DIMM, align it to an empty slot and press it in until the holding clips secure the DIMM in place.

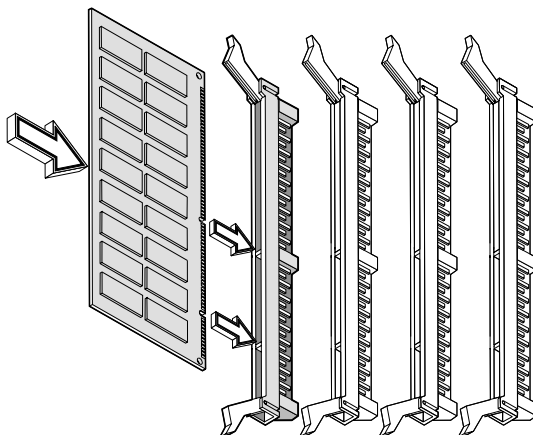



Note: The DIMM socket is slotted to ensure proper installation. If you slip in a DIMM but it does not completely fit, you may have inserted it the wrong way. Reverse the orientation of the DIMM.

To remove a DIMM, press the holding clips on both sides of the socket outward to release the DIMM.

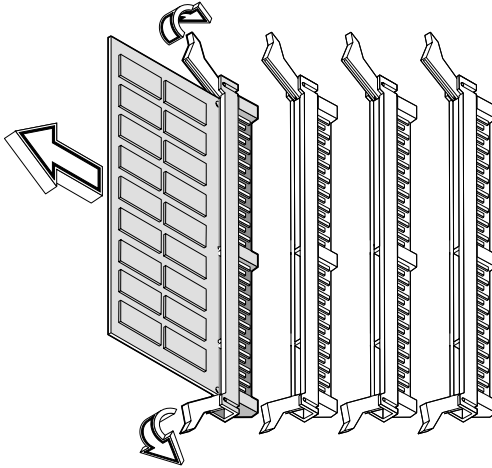

Note: Place your forefingers on the top of the DIMM before you press the holding clips to gently disengage the DIMM from the socket.

Reconfiguring the system

The system automatically detects the amount of memory installed. Run Setup to view the new value for total system memory and make a note of it.

4 Setup utility



This chapter gives information about the system BIOS and tells how to configure the system by changing the settings of the BIOS parameters.

► Introduction

Most systems are already configured by the manufacturer or the dealer. There is no need to run Setup when starting the computer unless you get a Run Setup message.

The Setup program loads configuration values into the battery-backed nonvolatile memory called CMOS RAM. This memory area is not part of the system RAM.



Note: If you repeatedly receive Run Setup messages, the battery may be bad. In this case, the system cannot retain configuration values in CMOS. Ask a qualified technician for assistance.

Before you run Setup, make sure that you have saved all open files. The system reboots immediately after you exit Setup.

▶ Entering Setup

To enter Setup, simultaneously press the key combination Ctrl+Alt+Esc.



Note: You must press Ctrl+Alt+Esc while the system is booting. This key combination does not work during any other time.

The system supports two Setup Utility levels: Basic and Advanced.

If you are an advanced user, you may want to check the detailed configuration of your system. Detailed system configurations are contained in the Advanced Level. To view the Advanced Level, press F8.

Use the Up and Down arrow keys to move around the Setup Utility screen.

Use the Left and Right arrow keys to move to the next page or to return to the previous page if the setup screen has more than one page available.

Use the Page Up, Page Down, +, or - keys to select the options if they are available.

Press Esc to return to the Main menu.



Note: A parameter with an asterisk (*) mark indicates that the parameter appears only when you are in the Advanced Level. Also, grayed items on the screens have fixed settings and are not user-configurable.

Basic Setup Utility screen

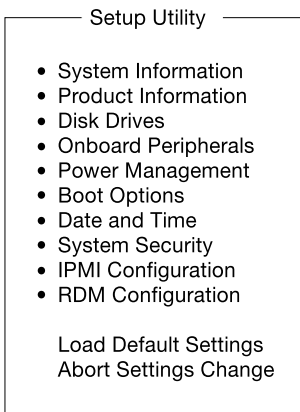

Advanced Setup Utility screen

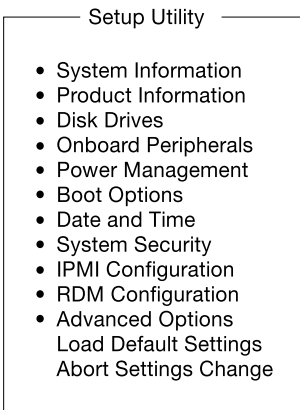

▶ System information

The following screen appears if you select System Information from the main menu:

System Information	
Processor.....	Pentium® III
Processor Speed.....	733 MHz
Level 1 Cache.....	32 KB, Enabled
Level 2 Cache.....	256 KB, Enabled
Floppy Drive A.....	None
Floppy Drive B.....	None
IDE Primary Channel Master.....	Hard Disk, xxxx MB
IDE Primary Channel Slave.....	None
IDE Secondary Channel Master.....	None
IDE Secondary Channel Slave.....	None
Total Memory.....	256 MB
1st Bank.....	Registered SDRAM, 64 MB
2nd Bank.....	Registered SDRAM, 64 MB
3rd Bank.....	Registered SDRAM, 64 MB
4th Bank.....	Registered SDRAM, 64 MB
Serial Port 1.....	3F8h, IRQ 4
Serial Port 2.....	2F8h, IRQ 3
Parallel Port.....	378h, IRQ 7
PS/2 Mouse.....	Installed

Parameter	Description
Processor	Type of processor currently installed in your system
Processor speed	Clock speed of the processor currently installed in your system
Level 1 cache size	Total amount of first-level or the internal fast accessed memory size (i.e., the memory integrated into the CPU)
Level 2 cache size	Total amount of second-level cache memory size that comes with the CPU. The available cache size is 256/512 KB

Parameter	Description
Floppy drive A and B	System's current diskette drive A and B settings
IDE primary channel master	Current configuration of the IDE device connected to the master port of the primary IDE channel
IDE primary channel slave	Current configuration of the IDE device connected to the slave port of the primary IDE channel
IDE secondary channel master	Current configuration of the IDE device connected to the master port of the secondary IDE channel
IDE secondary channel slave	Current configuration of the IDE device connected to the slave port of the secondary IDE channel
Total memory	Total amount of onboard memory. The memory size is automatically detected by BIOS during the POST. If you install additional memory, the system automatically adjusts this parameter to display the new memory size
1st/2nd/3rd/4th bank	Type and size of DRAM installed in DIMM sockets 1, 2, 3, and 4 respectively. The None setting indicates that there is no DRAM installed
Serial port 1	Serial port 1 address and IRQ setting
Serial port 2	Serial port 2 address and IRQ setting
Parallel port	Parallel port address and IRQ setting
PS/2 mouse	Pointing device installation settings. Displays None if no pointing device is installed

▶ Product information

Product Information contains the general data about the system, such as the product name, serial number, BIOS version, etc. This information is necessary for troubleshooting (may be required when asking for technical support).

The following shows how the Product Information screen appears:

Product Information	
Product Name.....	Acer Altos 1200LP
System S/N.....	xxxxxxxxxx
Main Board ID.....	M25C-1U
Main Board S/N.....	xxxxxxxxxx
System BIOS Version.....	VX.XX
SMBIOS Version.....	X.XX.X

Parameter	Description
Product name	Official name of the system
System S/N	System's serial number
Main board ID	Mainboard's identification number
Main board S/N	Mainboard's serial number
System BIOS version	Version of the BIOS utility
SMBIOS version	Version of the SMBIOS

▶ Disk drives

Select Disk Drives to input configuration values for disk drives.

The following screen shows the Disk Drives menu:

Disk Drives

Floppy Drive A.....[xx-MB, xx-inch]
 Floppy Drive B.....[xx-MB, xx-inch]

- IDE Primary Channel Master
- IDE Primary Channel Slave
- IDE Secondary Channel Master
- IDE Secondary Channel Slave

The following table describes the parameters in this screen. Settings in boldface are the default and suggested parameter settings.

Parameter	Description	Option
Floppy drive A and B	Selects the floppy disk drive type	1.44 MB, 3.5-inch None 360 KB, 5.25-inch 1.2 MB, 5.25-inch 720 KB, 3.5-inch 2.88 MB, 3.5-inch

Parameter	Description	Option
IDE primary channel master and slave	<p>These items let you select the IDE hard disk parameters that your system supports. Auto enables BIOS to automatically detect the parameters of installed HDDs during the POST (power-on self-test). If you prefer to enter HDD parameters manually, select User. Select None if no HDD is connected to the system.</p> <p>The IDE CD-ROM is always automatically detected</p>	
IDE secondary channel master and slave	<p>These items let you select the IDE hard disk parameters that your system supports. Auto enables BIOS to automatically detect the parameters of installed HDDs during the POST (power-on self-test). If you prefer to enter HDD parameters manually, select User. Select None if no HDD is connected to the system.</p> <p>The IDE CD-ROM is always automatically detected</p>	

IDE channel type

The following screen appears if you select any of the IDE drive parameters:

————— IDE Primary Channel Master —————

Device Detection Mode.....	[Auto]
Device Type.....	Hard Disk
Cylinder.....	[xxxx]
Head.....	[xx]
Sector.....	[xx]
Size.....	[xxxx] MB
Hard Disk LBA Mode.....	[Auto]
*Hard Disk Block Mode.....	{Auto}
*Hard Disk 32 Bit Access.....	[Enabled]
*Advanced PIO Mode.....	[Auto]
*DMA Transfer Mode.....	[Auto]

————— IDE Primary Channel Slave —————

Device Detection Mode.....	[Auto]
Device Type.....	None



Note: A parameter with an asterisk (*) mark indicates that the parameter appears only when you are in the Advanced Level. See "Entering Setup" on page 52 for how to view the advanced level.

Parameter	Description	Option
Device detection mode	Lets you specify the type of hard disk installed in your system. If you want BIOS to automatically configure your hard disk, select Auto. If you know your hard disk type, you can enter the setting manually	Auto User None
Device Type	Indicates a hard disk type device	
Cylinder	Specifies the number of cylinders of your hard disk, and is automatically set depending on your Type parameter setting	User Input
Head	Specifies the number of heads of your hard disk, and is automatically set depending on your Type parameter setting	User Input
Sector	Specifies the number of sectors of your hard disk, and is automatically set depending on your Type parameter setting	User Input
Size	Specifies the size of your hard disk, in MB	User Input
Hard disk LBA mode	This enhanced IDE feature allows the system to use a hard disk with a capacity of more than 528MB. This is made possible through Logical Block Address (LBA) mode translation. LBA is now considered a standard feature of current IDE hard disks on the market because of its capability to support capacities larger than 528MB. Note that if your HDD is formatted with LBA On, it will not be able to boot with LBA Off.	Auto Disabled

Parameter	Description	Option
Hard Disk Block Mode	This function enhances disk performance depending on the hard disk in use. If you set this parameter to Auto, the BIOS utility automatically detects if the installed hard disk drive supports the Block Mode function. If supported, it allows data transfer in block (multiple sectors) at a rate of 256 bytes per cycle. To disregard the feature, change the setting to Disabled.	Auto Disabled
Hard Disk 32-bit Access ???????	Enabling this parameter improves system performance by allowing the use of the 32-bit hard disk access. This enhanced IDE feature works only under DOS, Windows 3.x, Windows 95, Windows 98, Windows 2000 and Novell NetWare.	Enabled Disabled
Advanced PIO Mode	When set to Auto, the BIOS utility automatically detects if the installed hard disk supports the function. If supported, it allows for faster data recovery and read/write timing that reduces hard disk activity time. This results in better hard disk performance. To disregard the feature, change the setting to Disabled. This parameter appears only when you are in the Advanced Level.	Auto Mode 0 Mode 1 Mode 2 Mode 3 Mode 4
DMA transfer mode	The Ultra DMA and Multi-DMA modes enhance hard disk performance by increasing the transfer rate. However, besides enabling these features in the BIOS Setup, both the Ultra DMA and Multi-DMA modes require the DMA driver to be loaded.	Auto Multi word Mode 0, 1, 2 Ultra Mode 0,1,2,3,4 Disabled

▶ Onboard peripherals

Onboard Peripherals allows you to configure the onboard communication ports and the onboard devices. Selecting this option displays the following screen:

Onboard Peripherals	
Serial Port 1.....	[Enabled]
Base Address.....	[3F8h]
IRQ.....	[4]
Serial Port 2.....	[Enabled]
Base Address.....	[2F8h]
IRQ.....	[3]
Parallel Port.....	[Enabled]
Base Address.....	[378h]
IRQ.....	[7]
Operation Mode.....	[EPP]
ECP DMA Channel.....	[-]
Floppy Disk Controller.....	[Enabled]
IDE Controller.....	[Both]
PS/2 Mouse Controller.....	[Enabled]
USB Host Controller.....	[Enabled]
USB Legacy Mode.....	[Disabled]
Onboard SCSI.....	[Enabled]
Onboard Ethernet Chip 1.....	[Enabled]
Onboard Ethernet Chip 2.....	[Enabled]

The following table describes the parameters in this screen. Settings in boldface are the default and suggested parameter settings.

Parameter	Description	Option
Serial port 1	Enables or disables serial port 1	Enabled Disabled
Base address	Sets the I/O base address of serial port 1	3F8h 2F8h 3E8h 2E8h

Parameter	Description	Option
IRQ	Sets the IRQ (interrupt request) channel of serial port 1	4 11
Serial port 2	Enables or disables serial port 2	Enabled Disabled
Base address	Sets the I/O base address of serial port 2	2F8h 3F8h 3E8h 2E8h
IRQ	Sets the IRQ (interrupt request) channel of serial port 2	3 10
Parallel port	Enables or disables the parallel port	Enabled Disabled
Base address	Sets the I/O base address of the parallel port	378h 278h 3BCh
IRQ	Sets the interrupt request (IRQ) channel of the parallel port Note: If you install an add-on card that has a parallel port whose address conflicts with the onboard parallel port, a warning appears on the screen. Check the parallel port address of the add-on card and change the address to one that does not conflict	7 5

Parameter	Description	Option
Operation mode	<p>Selects the operation mode of the parallel port.</p> <p>Standard Parallel Port (Standard) - allows normal speed one-way operation.</p> <p>Standard and Bidirectional (Bidirectional) - allows normal speed operation in a two-way mode</p> <p>Enhanced Parallel Port (EPP) - allows bidirectional parallel port operation at maximum speed</p> <p>Extended Capabilities Port (ECP) - allows parallel port to operate in bidirectional mode and at a speed higher than the maximum data transfer rate</p>	<p>Bi-directional</p> <p>EPP</p> <p>ECP</p> <p>Standard</p>
ECP DMA channel	Sets the DMA channel of the parallel port when the parallel operation mode is set to ECP	<p>1</p> <p>3</p>
Floppy disk controller	Enables and disabled the onboard floppy disk controller	<p>Enabled</p> <p>Disabled</p>
IDE controller	Enables or disables the onboard IDE controller	<p>Both</p> <p>Primary</p> <p>Disabled</p>
PS/2 mouse controller	Enables or disables the onboard PS/2 mouse controller	<p>Enabled</p> <p>Disabled</p>
USB host controller	Enables or disable the onboard USB controller	<p>Enabled</p> <p>Disabled</p>
USB legacy mode	When enabled, allows you to use a USB keyboard in DOS. Set this to Disabled to deactivate the USB keyboard function in DOS	<p>Disabled</p> <p>Enabled</p>
Onboard SCSI	Enables or disables the onboard SCSI feature	<p>Enabled</p> <p>Disabled</p>

Parameter	Description	Option
Onboard ethernet chip 1	Enables or disables the first onboard network feature	Enabled Disabled
Onboard ethernet chip 2	Enables or disables the second onboard network feature	Enabled Disabled

► Power management

The Power Management menu allows you to configure the system power-management feature.

The following screen shows the Power Management parameters and their default settings:

```

Power Management

Power Management Mode.....[Enabled]
IDE Hard Disk Standby Timer..... [Off]
System Sleep Timer.....[Off]
Sleep Mode..... [------]

Power Switch <4 sec. .... [Power Off]

System wake-up event
Modem Ring Indicator..... [Disabled]
PCI Power Management.....[Enabled]
RTC Alarm.....[Disabled]
Resume Day..... [--]
Resume Time..... [--:--:--]
Restart on AC Power Failure.....[Pre-state]

```

The following table describes the parameters in this screen. Settings in boldface are the default and suggested parameter settings.

Parameter	Description	Option
Power management mode	Allows you to reduce power consumption. When this parameter is set to Enabled, you can configure the IDE hard disk and system timers. Setting it to Disabled deactivates the power-management feature and its timers	Enabled Disabled

Parameter	Description	Option
IDE hard disk standby timer	Allows the hard disk to enter standby mode after inactivity of 1 to 15 minutes, depending on your setting. When you access the hard disk again, allow 3 to 5 seconds (depending on the hard disk) for the disk to return to normal speed. Set this parameter to OFF if your hard disk does not support this function	Off 1 - 15 minutes
System sleep timer	This parameter sets the system to the lowest power-saving mode after a specified period of inactivity. Any keyboard or mouse action or any activity detected from the IRQ channels resumes system operation	Off 2 - 120 minutes
Sleep mode	Lets you specify the power-saving mode that the system will enter after a specified period of inactivity. This parameter becomes configurable only if the System Sleep Timer is on. Any keyboard or mouse action, or any enabled monitored activities occurring through the IRQ channels resume system operation	Standby Suspend
Power switch < 4 sec.	When set to Power Off, the system automatically turns off when the power switch is pressed for less than 4 seconds. When set to Suspend, the system enters the suspend mode when the power switch is pressed for less than 4 seconds	Power off Suspend
System wake-up event	The system wake-up event allows the system to resume operation when the modem ring indicator is enabled	
Modem ring indicator	When Enabled, any fax/modem activity wakes up the system from suspend mode	Enabled Disabled
PCI power management	Enables or disabled the PCI power management function	Enabled Disabled
RTC alarm	Allows you to set a certain time on a certain day to wake-up your system from suspend mode	Disabled Enabled

Parameter	Description	Option
Resume day	If RTC alarm is enabled, the system will resume operation on the day indicated here	User input
Resume time	If RTC alarm is enabled, the system will resume operation at the time indicated here	User input
Restart on AC power failure	Reboots the system when a power failure occurs. If disabled, the system does not automatically reboot from a power failure	Disabled Enabled Pre-state

▶ Boot options

This option allows you to specify your preferred settings for bootup.

The following screen appears if you select Boot Options from the main menu:

— Boot Options —

Boot Sequence
 1st [Floppy Disk A:]
 2nd [Hard Disk C:]
 3rd [IDE CD-ROM]

Primary Display Adapter.....[Auto]

Fast Boot.....[Auto]
 Silent Boot.....[Enabled]
 Num Lock After Boot.....[Enabled]
 Memory Test.....[Disabled]
 Release all Blocked Memory.....[Disabled]
 Boot from LANDesk(r) Service Agent.....[Enabled]
 *Configuration Table.....[Enabled]
 *POST Error Stop.....[Disabled]

Update BIOS with Boot Block.....[Disabled]



Note: A parameter with an asterisk (*) mark indicates that the parameter appears only when you are in the Advanced Level. See “Entering Setup” on page 52 for how to view the advanced level.

The following table describes the parameters in this screen. Settings in boldface are the default and suggested parameter settings.

Parameter	Description	Option
Boot sequence	<p>This parameter allows you to specify the boot search sequence during POST.</p> <p>1st. The system checks this drive first.</p> <p>2nd. The system then checks this drive if it can not boot from the 1st specified drive.</p> <p>3rd. If the 1st and 2nd searches fail then it boots from this drive.</p> <p>BIOS will display an error message if the drive(s) specified is not bootable</p>	
Primary display adapter	Lets you activate the onboard video controller as your primary display adapter, or automatically disable it once BIOS detects that there is a video card installed in your system	Onboard Auto
Fast boot	Allows the system to boot faster by skipping some POST routines	Disabled Auto
Silent boot	<p>Enables or disables the Silent Boot function. When set to Enabled, BIOS is in graphical mode and displays only an identification logo during POST and while booting. After booting the screen displays the operating system prompt (such as DOS) or logo (such as Windows 95). If any error occurs while booting, the system automatically switches to the text mode.</p> <p>Even if your setting is Enabled, you may also switch to the text mode while booting by pressing the Delete key when you see the "Press DELETE key to enter setup" message on the screen.</p> <p>When set to Disabled, BIOS is in the conventional text mode where you see the system initialization details on the screen</p>	Enabled Disabled
Num lock after boot	Allows you to activate the Num Lock function upon booting	Enabled Disabled

Parameter	Description	Option
Memory test	When set to Enabled, this parameter allows the system to perform a RAM test during the POST routine. When set to Disabled, the system detects only the memory size and bypasses the test routine	Disabled Enabled
Release all Blocked Memory	When set to Enabled, this parameter allows system to bypass testing the defective memory banks detected earlier.	Disabled Enabled
Boot from LANDesk service agent	When set to Enabled, the system boots from a LANDesk Service Agent network instead of your desktop system. The LANDesk Service Agent is IEEE-standards-based code that intervenes in the boot process. Please refer to your LANDesk Manual for more information. When set to Disabled, the system boots from the drive specified in the Boot Sequence parameter	Enabled Disabled
Configuration table	Displays preboot system configuration table when enabled	Enabled Disabled
Update BIOS with boot block	When enabled, it automatically flashes the BIOS file from the hard disk drive in case the system fails to boot up	Disabled Enabled
Post error stop	When enabled, the system automatically stop when an error occurs during POST. User has to press F1 to continue. If disabled, the system do not stop even when an error occurs during POST	Disabled Enabled

► Date and time

The real-time clock keeps the system date and time. After setting the date and time, you do not need to enter them every time you turn on the system. As long as the internal battery remains good (approximately seven years) and connected, the clock continues to keep the date and time accurately even when the power is off.

Date and Time

Date.....[WWW MMM DD, YYYY]
 Time.....[HH:MM:SS]

Parameter	Description
Date	Set the date following the weekday-month-day-year format. Valid values for weekday, month, day, and year are: Weekday: Sun, Mon, Tue, Wed, Thu, Fri, Sat Month: Jan, Feb, Mar, Apr, May, Jun, Jul, Aug, Sep, Oct, Nov, Dec Day: 1 to 31 Year: 1980 to 2079
Time	Set the time following the hour-minute-second format. Valid values for hour, minute, and second are: Hour: 00 to 23 Minute: 00 to 59 Second: 00 to 59

▶ System security

The Setup program has a number of security features to prevent unauthorized access to the system and its data.

The following screen appears if you select System Security from the Main menu:

System Security

Supervisor Password.....[None]
 User Password.....[None]

Disk Drive Control

 Floppy Drive.....[Normal]
 Hard Disk Drive.....[Normal]

Processor Serial Number.....[Disabled]

Supervisor password

The supervisor password prevents unauthorized access to the BIOS utility.

Setting and changing a password

To set or change a password:

1. Make sure that JP8 is set to 1-2 (bypass password). See “System board layout” on page 21 for the location of JP8.



.....

Note: You cannot enter the BIOS utility if a Setup password does not exist and JP8 is set to 2-3 (password check enabled). By default, JP8 is set to 1-2 (bypass password).

2. Enable the supervisor password parameter in the System Security menu by pressing the left or right arrow keys. The Supervisor Password window appears:

Supervisor Password

Enter your new Supervisor Password twice. Supervisor Password may be up to 7 characters long.

Enter Password.....[xxxxxxxxx]
 Enter Password again.....[xxxxxxxxx]

Set or Change Password

3. Type a password in the Enter Password field. The password may consist of up to seven characters.
4. Press the Enter key. Retype your password in the Enter Password again field to verify your first entry.
5. Highlight Set or Change Password and press the Enter key.
6. Press the ESC key to return to the System Security menu and then press the ESC key again to exit Setup. The Exit Setup screen appears:

Settings have been changed.
 Do you want to save to CMOS settings?

[Yes] [No]

7. Choose Yes to save your settings and exit the Setup utility. Your password will be saved to CMOS.

For the password to take effect you must set jumper JP8 to 2-3 (check password):

1. Turn off and unplug the computer.

2. Open the computer housing and set JP8 to 2-3 (check password) to check the password function. See “” on page 21 for the location of JP8.
3. Close your computer’s housing and reboot your system.

The next time you want to enter the BIOS utility, you must key in your supervisor password.

Removing a password

To remove your supervisor password:

1. Disable the Supervisor Password parameter in the System Security menu by pressing the left or right arrow key to select None.
2. Press the ESC key to return to the System Security menu and then press the ESC key again to exit Setup. The Exit Setup screen appears:

Settings have been changed. Do you want to save to CMOS settings?	
[Yes]	[No]

3. Choose Yes to save your settings and exit Setup. Your previous password will be removed from CMOS.



Note: Remember to set JP8 to 1-2 (bypass password) because you won't be able to access Setup if a password does not exist and JP8 is set to 2-3 (check password).

Bypassing a supervisor password

To bypass the supervisor password:

If you forget your supervisor password, you can bypass the password security feature by hardware. Follow these steps to bypass the password:

1. Turn off and unplug the computer.
2. Open the computer housing and set JP8 to 1-2 (bypass password) to bypass the password function. See “System board layout” on page 21 for the location of JP8.

- Turn on the system and enter the BIOS utility. This time, the system does not require you to type in a password.



Note: You can either change the existing supervisor password or remove it by selecting None.

User password

The user password secures your system against unauthorized use. Once you set this password, you have to type it whenever you boot the system. To set this password, enter the Setup utility, select System Security, and then highlight the User Password parameter. Follow the same procedure as in setting the “Supervisor password” on page 73.



Note: Make sure to set JP8 to 2-3 to enable the user password.

User Password	
Enter your new User Password twice. User Password may be up to 7 characters long.	
Enter Password.....	[xxxxxxx]
Enter Password again.....	[xxxxxxx]
Set or Change Password	

Disk drive control

The disk drive control features allow you to control the floppy drive or the hard disk drive boot function to prevent loading operating systems or other programs from a certain drive while the other drives are operational (under DOS mode only).

Floppy drive and hard disk drive

Setting	Description
Normal	Floppy drive or hard disk drive functions normally
Write Protect All Sectors	Disables the write function on all sectors
Write Protect Boot Sector	Disables the write function only on the boot sector

Processor serial number

The Pentium III processor incorporates an individual serial number in each chip that can identify individual CPUs. When Enabled, CPUs can be identified by processor serial number. Disable this parameter to deactivate this feature.

▶ IPMI configuration

Intelligent Platform Management Interface

The system event log enables you to record and monitor events that occur in your system like system temperature changes, fan stops, and others. This feature also allows you to specify the appropriate settings for your system's event handling.

```

IPMI Configuration
-----
IPMI Specification Version.....1.0
IPMI BIOS Version.....1.0 000608
BMC Firmware Version.....0.22

System Event Logging.....[Enabled]
Clear Event Log Area.....[Disabled]
Existing Event Log Number.....1
Remaining Event Log Number.....381

• View Event Logs

Event Control
  BIOS POST.....[Enabled]
  Memory ECC.....[Enabled]
  PCI Devices.....[Enabled]
  
```

The following table describes the parameters in the IPMI configuration screen. Settings in boldface are the default and suggested parameter settings.

Parameter	Description	Option
IPMI specification version	Specifies the version of Intelligent Platform Management Interface (IPMI)	
IPMI BIOS version	Shows the version of IPMI BIOS	
BMC firmware version	Specifies the version of BaseBoard Management Controller (BMC) Firmware	

Parameter	Description	Option
System Event logging	Enables or disables the event logging function of your system	Enabled Disabled
Clear event log area	Clears the event log whenever the event log area is full	Disabled Enabled
Existing event log number	Number of events currently located in the event log area	
Remaining event log number	Number of space that is still available for logging system events	
View event logs	Opens the system event log file for viewing	
Event control		
BIOS POST	BIOS checks the bad processors and memory modules during POST. When this parameter is Enabled, BIOS will stop POST operation whenever it finds a bad processor or memory. Otherwise, if Disabled the system will continue running	Enabled Disabled
Memory ECC	ECC or error correcting code tests the accuracy of data as it passes in and out of memory. This parameter enables or disables the monitoring of this function	Enabled Disabled
PCI devices	PCI or Peripheral Component Interconnect is a 32-bit bus that supports a 64-bit extension for new processors, such as the Pentium. It can run at clock speeds of 33 or 66 MHz. This parameter monitors the activity of this bus when set to enabled	Enabled Disabled

► RDM configuration

```

RDM Configuration

RDM v4.3 BIOS Version.....000613
Console Redirection.....[Disabled]

Hidden Partition.....[Disabled]

Communication Protocol.....[N,8,1]
COM Port Baud Rate.....[57600]
*Detect Tone.....[Enabled]
Remote Console Phone No.....[      ]
Dial Out Retry Times.....[2]

*Modem Initial Command.....[      ]

Emergency Management
RDM Work Mode.....[Disabled]
Connect-in Password.....[      ]
Paging Times.....[1]
Paging No.:
1. [      ]
2. [      ]

```



Note: A parameter with an asterisk (*) mark indicates that the parameter appears only when you are in the Advanced Level. See “Entering Setup” on page 52 for how to view the advanced level.

The following table describes the parameters in the console redirection screen. Settings in boldface are the default and suggested parameter settings.

Parameter	Description	Option
RDM 4.3 BIOS version	Shows the version number of the RDM BIOS	

Parameter	Description	Option
Console redirection	This parameter lets you enable or disable the connection to the RDM manager station. If enabled and conditions are met, the RDM enabled server automatically dials the RDM manager station using the phone number specified in the Remote Console Phone No. parameter when the server reboots. Once the connection is established, both the RDM server and RDM manager station display the same screen which enables the RDM manager station to function the same as the server console. Setting this to Disabled deactivates the RDM manager station	Disabled Enabled
Hidden partition	If you want the hidden partition to become accessible, set this parameter to Enabled. When enabled, the server boots to the hidden partition, vice versa	Disabled Enabled
Communication protocol	This parameter specifies the parity, stop bits, and data length for the COM port to be used for the RDM connection. This is fixed at N (none), 8, 1 setting and is non-configurable	N, 8, or 1
COM port baud rate	This parameter lets you set the transfer rate of the COM for the RDM connection. The parameter setting depends on your modem specification; therefore, before you change the setting of this parameter, check your modem user guide	9600 57600
Detect tone	When enabled, RDM checks for the existence of the telephone tone first before it dials out. when disabled, RDM proceeds with the dialing process without checking for the telephone tone	Enabled Disabled

Parameter	Description	Option
Remote console phone no.	<p>This parameter allows you to set the phone number of the RDM manager station that the RDM module must dial once RDM is activated and the Remote Console is enabled. To set, simply highlight the parameter and enter the Remote Console phone number.</p> <p>If the remote console phone number is using an extension line, then you must enter six commas (,) after the phone number and before the extension number, if any. When entering the extension number, we recommend that you insert a comma after each number. The commas specify delay.</p> <p>If this parameter is left blank, the Remote Console calling function is disregarded</p>	User input
Dial out retry times	<p>This parameter lets you specify the maximum number of times the RDM server must retry to connect to the RDM manager station once the server fails and RDM is activated. If the server has completed the specified number of tries and the connection still fails, the server bypasses RDM and goes into normal mode</p>	2 4 8 Infinite
Modem initial command	<p>Some modems require specific commands for initialization. This parameter allows you to specify the required command to enable your system to support special types of modems. If you do not specify any command, BIOS uses the default method to initialize the modem*</p>	User input

Parameter	Description	Option
Emergency management		
RDM work mode	<p>When detecting system failure, the RDM module will take some actions according to the mode.</p> <ol style="list-style-type: none"> 1. Waiting: Paging and waiting RDM Station to call in. 2. Reboot: Paging, then reboot. 3. Disabled: No action <p>Note: If Waiting is selected, password must be set to at least three characters</p>	Disabled Waiting Reboot
Connect-in password	Prevents unauthorized access to the server	User input
Paging times	Allows you to set the number of times that the RDM module must dial when the server fails or hangs	1,2,4, or 8
Paging No.	Allows you to set the pager number that the RDM module must dial when the server fails or hangs	User input

* Specify an initialization command only when you receive a Modem Initial Command Fail error message. Otherwise, leave this parameter blank.

▶ Advanced options



.....

Note: Do not change any settings in the Advanced Options if you are not a qualified technician to avoid damaging the system.

The following screen shows the Advanced Options parameters:

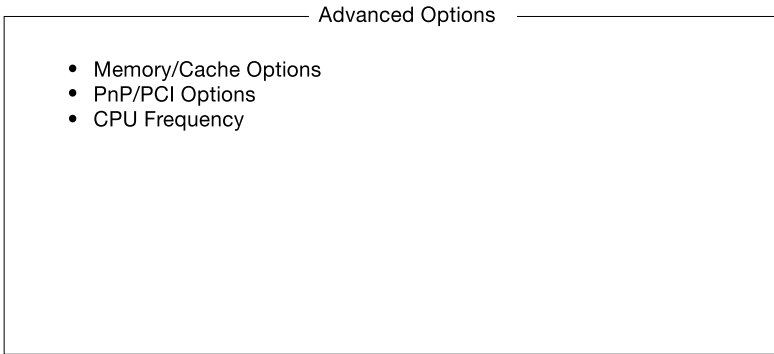

Memory/Cache options

Memory/Cache Options allows you to configure the advanced system memory functions.

Memory/Cache Options	
Level 1 Cache	[Enabled]
Level 2 Cache.....	[Enabled]
Memory at 15MB-16MB Reserved for.....	[System]

Parameter	Description	Option
Level 1 cache	Enables or disables the first-level or internal memory, that is, the memory integrated into the CPU	Enabled Disabled
Level 2 cache	Enables or disables the second-level cache memory which is incorporated in the CPU module	Enabled Disabled
Memory at 15MB-16MB reserved for	To prevent memory address conflicts between the system and expansion boards, reserve this memory range for the use of either the system or an expansion board	System Add-on Card

PnP/PCI options

PnP/PCI Options allows you to specify the settings for your PCI devices. Selecting this option displays the following screen:

```

PnP/PCI Configuration
-----
PCI IRQ Setting.....[ Auto ]
                                INTA INTB INTC INTD
PCI Slot 1.....[--]  [--]  [--]  [--]
Onboard VGA.....[--]
Onboard LAN.....[--]
Onboard SCSI.....[--]  [--]
USB Host Controller.....[--]

PCI IRQ Sharing.....[Yes ]
VGA Palette Snoop.....[Disabled]
Plug and Play OS.....[No]
Reset Resource Assignments.....[No ]
    
```

Parameter	Description	Option
PCI IRQ setting	Select Auto to let BIOS automatically configure the plug-and-play (PnP) devices installed on your system; otherwise, select Manual Note: Refer to your manual for technical information about the PCI card	Auto Manual
PCI slots 1	When you set the PCI IRQ Setting parameter to Auto, these parameters specify the auto-assigned interrupt for each of the PCI devices. If you set the PCI IRQ Setting parameter to Manual, you need to specify the interrupt that you want to assign for each PCI device installed in your system	User input
Onboard VGA	Allows you to manually assign the interrupt for the onboard VGA when the PCI IRQ Setting parameter is set to Manual. This parameter is grayed and not user-configurable when the PCI IRQ Setting is set to Auto	User input

Parameter	Description	Option
Onboard SCSI	Allows you to manually assign the interrupt for the onboard SCSI when the PCI IRQ Setting parameter is set to Manual. This parameter is grayed and not user-configurable when the PCI IRQ Setting is set to Auto	User input
Onboard LAN	When you set the PCI IRQ Setting parameter to Auto, this parameter specifies the auto-assigned interrupt for the onboard LAN. If you set the PCI IRQ Setting parameter to Manual, you need to specify the interrupt that you want to assign for the onboard LAN installed in your system	User input
USB host controller	Allows you to manually assign the interrupt for the USB host controller when the PCI IRQ Setting parameter is set to Manual. This parameter is grayed and not user-configurable when the PCI IRQ Setting is set to Auto	User input
PCI IRQ sharing	Setting this parameter to Yes allows you to assign the same IRQ to two different devices. To disable the feature, select No. Note: If there are no IRQs available to assign for the remaining device function, we recommend that you enable this parameter	Yes No

Parameter	Description	Option
VGA palette snoop	<p>This parameter permits you to use the palette snooping feature if you installed more than one VGA card in the system.</p> <p>The VGA palette snoop function allows the control palette register (CPR) to manage and update the VGA RAMDAC (Digital Analog Converter, a color data storage) of each VGA card installed in the system. The snooping process lets the CPR send a signal to all the VGA cards so that they can update their individual RAMDACs. The signal goes through the cards continuously until all RAMDAC data has been updated. This allows the display of multiple images on the screen.</p> <p>Note: Some VGA cards have required settings for this feature. Check your VGA card manual before setting this parameter</p>	<p>Disabled</p> <p>Enabled</p>
Plug and play OS	<p>When this parameter is set to Yes, BIOS initializes only PnP boot devices such as SCSI cards. When set to No, BIOS initializes all PnP boot and non-boot devices such as sound cards.</p> <p>Note: Set this parameter to Yes only if your operating system is Windows 95/98</p>	<p>Yes</p> <p>No</p>
Reset resource assignments	<p>Set this parameter to Yes to avoid IRQ conflicts when installing non-PnP or PnP ISA cards. This clears all resource assignments and allows BIOS to reassign resources to all installed PnP devices the next time the system boots. After clearing the resource data, the parameter resets to No</p>	<p>No</p> <p>Yes</p>

CPU Frequency

This parameter displays your CPU's speed and bus frequency. Selecting this option displays the following screen:

CPU Frequency	
Bus Frequency	133 MHz
CPU Frequency Multiplier.....	[5X]
Processor Speed.....	667 MHz
Single Processor MP Table.....	[Enabled]
MP Table Version.....	[V1.4]

Parameter	Description	Option
Bus frequency	The bus frequency refers to the speed by which data is transferred between internal computer components and the CPU or the main memory of the CPU. A fast bus allows data to be transferred faster, which makes applications run faster	
CPU Frequency Multiple	This column shows the CPU core/bus ratio of your system. The clock speed of the bus does not necessarily equal the CPU's (core). Mostly, the bus clock speed is slower than the CPU clock speed. System BIOS will detect CPU frequency and set CPU Frequency Multiple automatically.	
Processor speed	The processor speed is the speed at which a microprocessor executes instructions. Clock speeds are expressed in megahertz (MHz), with 1 MHz being equal to 1 million cycles per second. The faster the clock, the more instructions the CPU can execute per second	

Parameter	Description	Option
Single Processor MP Table	<p>Enabling this parameter allows BIOS to create a multiprocessor (MP) table for Windows NT use. In a single-processor system running Windows NT, you may disable this parameter to enhance system performance. If you install another CPU for a dual system, enable this parameter then re-install Windows NT.</p> <p>In cases when this parameter is enabled before installing Windows NT in a single-processor system, you may upgrade to a multiprocessor system without reinstalling Windows NT.</p>	Enabled Disabled
MP Table version	Version number of the MP table.	

► Load default settings

Use this option to load the default settings for the optimized system configuration. When you load the default settings, some of the parameters are grayed-out with their fixed settings. These grayed parameters are not user-configurable.

The following dialog box appears when you select Load Default Settings from the main menu:

Do you want to load default settings?

[Yes] [No]

Select Yes to load the default settings.

Select No to ignore the message and return to the BIOS utility.

▶ Abort settings change

Use this option to disregard your changes to the BIOS and reload your previous settings.

The following dialog box appears when you select Abort Settings Change from the main menu:

Do you want to abort settings change?

[Yes] [No]

Select Yes to disregard your changes and reload your previous settings. After reload, the main menu appears on the screen.

Select No to ignore the message and return to the BIOS utility.

▶ Exit Setup

Examine the system configuration values. When you are satisfied that all the values are correct, write them down. Store the recorded values in a safe place. In the future, if the battery loses power or the CMOS chip is damaged, you will know what values to enter when you rerun Setup.

Press the ESC key to leave Setup. The following dialog box appears:

<p>Do you really want to exit SETUP?</p> <p>[Yes] [No]</p>

Use the arrow keys to select your response. Press the Enter key.

If you made any changes to the Setup utility, the dialog box below is displayed.

<p>Settings have been changed. Do you want to save to CMOS settings?</p> <p>[Yes] [No]</p>

Use the arrow keys to select your response. Select Yes to save the changes in CMOS. Select No to retain the previous configuration values. Press the Enter key to exit.



Appendix A: ASM Pro quick installation guide

This appendix shows you how to set up ASM Pro and its agent software.

► Installing ASM Pro

System requirements

ASM Console

- Intel Pentium or higher processor
- 64MB of RAM (128MB recommended)
- 20MB free hard disk space
- Microsoft Windows 95, Windows 98, Windows NT, or Windows 2000 operating system
- Ethernet card
- Modem

ASM Server and Desktop agents

- Intel Pentium or higher processor
- 64MB of RAM (128MB recommended)
- 20MB free hard disk space
- Novell NetWare, SCO OpenServer, SCO UnixWare, Linux RedHat, Microsoft Windows NT, or Windows 2000 operating system
- Ethernet card
- Modem (optional for RAS/OOB^{*})

System setup

Make sure that your computer meets the system requirements before proceeding. You may also want to change your screen to 800 x 600 resolution or higher for optimum viewing.

* RAS (Remote Access Services) and OOB (Out-of-Band)

Installing ASM Console

To install ASM Console:

1. Insert the Resource CD into the CD-ROM drive on your system.
2. Click on the Startup icon.
3. Click on Software Installer, and select ASM Console.
4. Follow the Installation Wizard.
5. Click Finish to complete the installation.



Note: Remember to remove all diskettes or CDs from the drives before rebooting the system.

Installing ASM Server Agent

ASM Server Agent can be installed on four different operating systems. The installation diskette contains the installation files for the following operating systems:

- Novell NetWare 5.x, 4.11
- SCO OpenServer 5.0
- SCO Unixware 7.x
- Microsoft Windows NT 4.0 Server
- Linux RedHat 6.2
- Microsoft Windows 2000 (Server and Advanced Server)

Installing the Novell NetWare Server Agent



Note: Make sure the SNMP (Simple Network Management Protocol) is configured properly.

ASM Server Agent requires SNMP.NLM running with *Control Community set to 'public'*; to allow ASM Console to communicate with ASM Server Agent.

ASMAGENT.NCF is the script file that loads all related modules of ASM Server Agent. To load the SNMP use the following command:

```
load snmp control=public
```

If you load SNMP.NLM before ASM Server Agent, make sure that the Control Community has been set up properly. For more information, please refer to related documents about the SNMP Agent for NetWare (NetWare SNMP).

Check AUTOEXEC.NCF to see if you have loaded SNMP. Notice that because of the auto loading feature of NLM, you can not directly find where SNMP is loaded. The most common module is TCPIP.NLM which auto loads SNMP.NLM. If you are using TCP/IP, load SNMP by using the command line *load snmp control=public* before loading TCPIP.

For NetWare 4.x and Netware 5.x users, if you are using INETCFG.NLM to configure the network, be sure to configure SNMP and make sure that the SNMP.NLM is running with *Control Community set to 'public'*.

To install the Novell NetWare Server Agent:

1. Use the diskette maker utility on the Startup Resource CD to create your NetWare installation diskette.
2. Insert the diskette into the NetWare server's drive.
3. At the NetWare server console, type:

```
Load A: setup
```

4. You are asked if you want to install the ASM Server Agent on your system. Select Yes to install.

The setup program detects the NetWare version and the model of the server. It copies related NLM files into the SYS: SYSTEM directory and C: of your NetWare server, and some needed command lines are added into AUTOEXEC.NCF in SYS: SYSTEM.

5. If the Mylex GAM driver and GAM service is installed in your NetWare system, the setup program asks you to install the Bbp agent.
6. Press any key to continue. The ASM Server Agent Configuration Utility is launched.
7. The Password option is highlighted. Set up a password, and exit the utility.



.....

Note: A password is required when using the ASM Console to remotely change or set any values for the agent, such as threshold values and any trap handling method. If the password is disabled, there is no security protection for the agent when the Console tries to change or set these values.

8. Reboot the system to activate the ASM drivers.



.....

Note: ASM Server Agent automatically starts after the server is restarted and running.

Installing the SCO OpenServer Agent



.....

Note: Make sure the SNMP (Simple Network Management Protocol) is configured properly.

ASM Server Agent requires SNMP running with *community set to 'public'*. The IP address of ASM Console should be in */etc/snmpd.trap* so that ASM Console can communicate with ASM Server Agent.

Follow these steps to install the SCO Server Agent:

If the ASM installation diskette is already available, go to Step 2. Otherwise, perform Steps 1 to make the ASM installation diskette from the diskette image file on the ASM package CD-ROM.

1. Use the Diskette Maker utility on the Startup Resource CD to create your SCO OpenServer installation diskette.
2. If you are in the desktop window, click on the Software Manager icon. If you are at the UNIX shell prompt, type "custom" and press Enter.
3. From Software Manager or the custom program, select Software and then Install New.
4. The "Begin Installation" screen appears. Follow the onscreen instructions. Click on Continue to accept the defaults.
5. When the Select Media screen appears, highlight Floppy Disk Drive 0 and select Continue.
6. At the Install Preferences menu, select Full. The *asmconfig* screen appears.



.....

Note: If the SCO Server Agent has been installed, the program asks if you want to preserve the existing config file. Choose Reinstall to overwrite the previously installed SCO Server Agent, or choose Upgrade if you know the existing password.

7. A password is required for a new installation. The system prompts you to enter a new password, and after you have entered it once, prompts you to reenter it.
8. After you set up the password, select the *SNMP_Config* option, and enter the IP address of the ASM Console system. (You can run *asmconfig* at a later time to add or change the ASM Console IP address. See the ASM Server Agent Utilities chapter in the ASM Pro manual for information about running *asmconfig*.)



Note: If the SCO Server Agent has been installed, target IP addresses appear on this screen.

The installation process adds the ASM agent driver to the SCO operating system, and the following message appears before the kernel relinks.

Adding device to system configuration files. . .

When the installation is complete, the following message appears:

Installation Complete.

9. Exit Software Manager or the custom program, and reboot the system.

Configuring ASM Server Agent for SCO OpenServer

You may disable the password if you are installing ASM Server Agent to use only UPS (Uninterruptible Power Supply) or RDM functions.

You can use the `asmconfig` utility to set up a password for the agent. A password is required when you are using ASM Console to remotely change or set any values for the agent.

Refer to the ASM Server Agent Utilities chapter in the ASM Pro manual for instructions on how to use the `asmconfig` utility.

Installing the SCO UnixWare Server Agent



Note: All of the following procedures require root permission.

To install the SCO UnixWare Server Agent:

1. Make the ASM installation diskette from the DD file on the ASM package CD-ROM.
2. Mount the CD-ROM drive. For example, mount the CD-ROM to `/mnt`.
3. Insert an empty 1.44MB diskette into your floppy drive and execute the command:

```
# dd if={PATH}/asmuw.dd of=/dev/rdisk/f03ht
```

Here, `{PATH}` denotes the directory where `asmuw.dd` is located. For example, `/mnt/UnixWare`.

4. Insert the ASM installation diskette into your floppy drive and, at the shell prompt, execute this command to begin ASM installation:

```
# pkgadd -d diskette1 asm
```

The installation process copies the ASM Server Agent package into the /usr/asm directory, and automatically makes changes to the following system configuration files:

```
/etc/netmgt/snmpd.comm
```

```
/etc/netmgt/snmpd.peers
```

```
/etc/inittab
```

After the installation is complete, ASM Server Agent can be manually started by executing the command:

```
# /usr/asm/asmsmuxd
```

or it will automatically be started on the next system reboot.



Note: Before starting ASM SMUX Agent asmsmuxd, execute the ASM Agent Configuration Utility asmcfg to configure at least "SNMP", "ASM_Password" and other parameters. Refer to "Chapter 4 - ASM Server Agent Utilities" in the ASM Pro manual for detailed instructions on using the ASM Configuration Utility.

Installing the Microsoft Windows NT Server Agent



Note: Before installing the ASM software, make sure that the TCP/IP and its related SNMP service are installed on the server.

Follow these steps to install the Windows NT agent:

1. Insert the installation CD-ROM into your drive after booting NT and logging in as the system administrator.
2. Click on the Start button and select Run. A dialog box appears that allows you to specify the setup program in the NT directory of the installation CD.
3. Verify the path and click OK. The Welcome screen appears.
4. Click Next. You are asked to stop SNMP service.

5. Click Yes. You are prompted to choose a destination directory. If you only want to install ASM SNMP agent and Remote Console, you can choose Typical. If you want to choose more components, click Custom. There are five components in ASM agent:

- SNMP agent
- DMI

ASM Pro agent defines a proprietary ASM.MIF that supports the same items as the SNMP agent.

- Server Mif

The server.mif that defined by DMTF will be installed.

- Remote Console

The Remote Console Server is installed which can be remote control by Remote Console Client

- MMC

This component is only supported on Windows 2000. And it is integrated with Microsoft Management Console.

6. Click Next, for the default directory, or click on Browse to find your own destination directory. Check any components you want to install, and click OK.

The asmcfg utility launches automatically.

You may skip steps 7 through 11 if you are installing ASM Server Agent solely for the purpose of utilizing UPS and/or RDM functions.

7. Enter a password and click OK. A password is required when using the ASM Console to remotely change or set any value for the NT Agent. If the password is disabled, there is no security protection for the agent when the ASM Console tries to change or set these values.
8. Enter the IP address of the ASM Console system, then click ADD to add trap destinations. Click OK to end the asmcfg utility. This IP address tells the Agent where to report (trap).
9. Click Yes to save your changes. The view readme file dialog box appears.
10. Click Yes to view, No to continue.
11. Click Finish to exit setup.

► Installing RDM

This section gives step-by-step instructions on how to install the RDM module, the RDM function in agent side and console side of ASM Pro software.

System requirements

Before you begin the installation, make sure that you have the following:

RDM server requirements

Hardware

- External modem
- RDM module
- RDM LED indicator
- Pager

Software

- Novell NetWare v4.1 or later, and/or
- SCO OpenServer 5.0 or later, and/or
- Microsoft Windows NT 4.0 or later, and/or
- SCO UnixWare 7.0 or later
- ASM (Advanced System Manager) agent
- RDM v4.3 package

RDM Manager Station requirements

Hardware

- Pentium or faster PC
- At least 16-MB RAM
- At least 5-MB free hard disk space
- Modem

Software

- Microsoft Windows 95/98, Microsoft NT Workstation 4.0, or Windows 2000
- ASM Console 4.3 Console

RDM server setup

This section describes how to set up the RDM server.

Installing RDM module



Note: The RDM module is installed at the Acer factory. The following RDM module instructions is provided in the event you need to reinstall the RDM module. See xx the Connecting Communication Peripherals section for information about installing a modem, telephone, or pager.

ESD precautions

Electrostatic discharge (ESD) can damage your processor, disk drives, expansion boards, and other components. Always observe the following precautions before you install a system component.

- Do not remove a component from its protective packaging until you are ready to install it.
- Wear a wrist grounding strap and attach it to a metal part of the system unit before handling components. If a wrist strap is not available, maintain contact with the system requiring ESD protection at all times.

Preinstallation instructions

Always observe the following before you install a system component:

- Turn off and unplug the system and all the peripherals connected to the unit before opening it.
- Open the system housing.
- Follow the ESD precautions listed above before handling a system component.
- Remove any expansion boards or peripherals that block access to the desired system board slot or connectors.

- See the following sections for specific instructions on the component you wish to install.

Installing the RDM module

1. Open the system housing.
2. Align the module connectors with their corresponding connectors on the system board.
3. Gently insert the module. Make sure not to bend the pins and that the module is properly seated.
4. Replace the housing cover.
5. Enter BIOS Setup to set the desired RDM Work Mode.

Connecting communication peripherals

Modem

The RDM server and the RDM manager station communicate via modem protocol. Therefore, you need to connect an external modem with a baud rate of not less than 9600 bps to both systems. To connect an external modem, connect the RS232C serial cable to the modem data port and the appropriate COM port of the system.



Note: The modem at the RDM server side must be connected to the COM2 port, while the modem at the RDM manager station side can be connected to either the COM1 or COM2 port. Use only modems that are purchased locally to ensure compatibility with your telephone system. The modem must have a transfer rate of at least 28.8K.

When the modem is turned ON, the CD/DCD (Carrier Detect/Data Carrier Detect) signal light on the front panel must be OFF for RDM to function properly. If this is not the case, refer to the modem's user's guide and check the section on DIP switches for information on how to adjust the CD/DCD light. If your modem does not have a DIP switch, then we recommend that you replace it with another model that supports such switches.

Telephone

To connect the modem to a telephone outlet, plug in the telephone connector to the telephone outlet. Then, insert the telephone line connector to the modem line port.

Pager

The pager is necessary for notification purposes only.

Post-installation instructions

Observe the following after installing a system component:

- Make sure that the components are installed according to the step-by-step instructions in their respective sections.
- Replace any expansion boards or peripherals that you removed earlier.
- Replace the system cover.
- Connect the necessary cables.
- Turn on the system and the peripherals connected to it.

Installing RDM agent software

You must do the following to ensure successful installation of the RDM agent software:

1. Create a hidden RDM partition.

The hidden RDM partition is a DOS partition on the hard disk that allows you to run preinstalled diagnostic tools when necessary, without using a diskette or a CD. It also allows you to access your system from a remote RDM manager station.

To create a hidden RDM partition, do the following:

- Prepare a "clean" hard disk, i.e., a hard disk without any operating system installed on it.
- Insert a DOS bootable floppy diskette into the diskette drive.
- After booting from the floppy diskette drive, use the DOS FDISK command to create a DOS partition. The minimum partition size is 33 MB.
- Activate the partition and exit FDISK; then reboot the system.
- Format the DOS partition. When formatting is completed, label the partition as RDM for easy identification.
- Install (or transfer) the DOS operating system to the partition.
- Run `\agent\install.bat*` to install the RDM driver and hide the RDM partition. These settings will take effect only after you reboot the system.

After you create the hidden partition, you can now install other operating systems on the same hard disk. But before doing so, make sure that the Hidden Partition parameter in the RDM BIOS is set to Disabled. For more information on RDM BIOS, refer to RDM BIOS chapter of the ASM Pro manual.



Important! If you are using an IDE hard disk with a capacity less than 540 MB, make sure that you disable the LBA mode. Otherwise, you will be required to use the LBA mode that you set for the other operating systems when you create the hidden RDM partition.



Note: When you boot the system to the hidden partition, you cannot use other utilities (e.g., FDISK.EXE) to change the hidden partition settings.

Deleting the hidden partition



Important! You cannot recreate the RDM hidden partition once you delete it. Before proceeding, make sure that you will not need to create a hidden partition in the future.

Follow these steps to delete the hidden partition:

- Insert a bootable diskette into the diskette drive.
 - Enter the BIOS Setup and set the Hidden Partition parameter in the RDM BIOS to Enabled.
 - After the system boots from the diskette drive, use FDISK to delete the RDM hidden partition. Do not delete other partitions or change or reformat the active partition.
 - Exit FDISK and reboot the system.
 - Enter the BIOS Setup and set the Hidden Partition parameter in the RDM BIOS to Disabled.
2. Install an operating system.

RDM supports the following operating systems:

- Novell NetWare
- Microsoft Windows NT and Windows 2000
- SCO OpenServer

- SCO UnixWare

You can install any or all of the operating systems. For the installation instructions, refer to the documentation that came with the OS package.

3. Install the RDM Agent Driver.



Note: Before you proceed, make sure that you have installed the necessary components and peripherals, for both the RDM server and RDM station.

The RDM agent driver or the server driver is contained in the Advanced System Manager Pro (ASM Pro) software package. Therefore, to install the RDM agent driver, you need to install the ASM agent software. For information on how to install the ASM software, refer to the documentation that comes with the ASM package.

4. Enable the driver.

After installing the ASM Agent driver, the system automatically enables the RDM driver. You do not need to enable the RDM driver manually unless you have previously disabled it for some reason.



Note: We strongly recommend that you do NOT disable the RDM driver. If you disable the RDM driver, RDM manager station will not be able to establish remote access to the server in the event of a system failure.

NetWare

To enable the RDM driver in a Netware environment, type:

```
# LOAD MAGENT
```

To disable the driver, type:

```
# UNLOAD MAGENT
```

Windows NT

To enable the RDM driver in a Windows NT environment, open a command prompt and type:

```
STARTRDM.EXE
```

To disable the RDM driver in a Windows NT environment, open a command prompt and type:

CANCEL.EXE

SCO OpenServer

To enable the RDM drivers in an SCO OpenServer environment, type:

```
#!/XSNMPD/RDMTESTTART
```

where #/XSNMPD is the directory that contains the RDM drivers.

To disable, type:

```
#!/XSNMPD/RDMTEST CANCEL
```

SCO UnixWare

To enable the RDM drivers in an SCO Unixware environment, type:

```
#!/USR/ASM/RDMTEST START
```

To disable, type:

```
#!/USR/ASM/RDMTEST CANCEL
```

► Installing AWM and Microsoft IIS

System requirements

- Intel 486 or higher processor
- 64MB of RAM
- 10MB free hard disk space
- Windows NT Server 4.0 or Windows 2000 with the following:
 - Microsoft Internet Information Server 2.0 or later (4.0 is recommended)
 - Microsoft Active Server Pages (ASP)
 - SNMP Service
- Ethernet card
- Modem

Installing AWM

To install AWM:

1. Insert the Resource CD into the CD-ROM drive on your system.
2. Click on the Startup icon.
3. Click on Software Installer, and select AWM.
4. Follow the Installation Wizard.
5. Click Finish to complete the installation.



.....

Note: For Windows NT 4.0, AWM will automatically install WbEM core or WbEM SNMP Provider if not installed. For Windows 2000, the WbEM core is built-in. AWM will only install the WbEM SNMP Provider if it is not yet installed. After installing either of these components, the system needs to reboot.

Setting up Microsoft IIS



.....

Note: If you have IIS version 4.0 or later the directory is automatically added.

To set up Microsoft IIS:

1. Open your IIS configuration program and check the virtual directory setting.
2. Check the virtual directory. If there is no virtual directory for AWM, create one and name it AWM. Point it to the directory where the AWM main files are installed (e.g. C:/AWM).

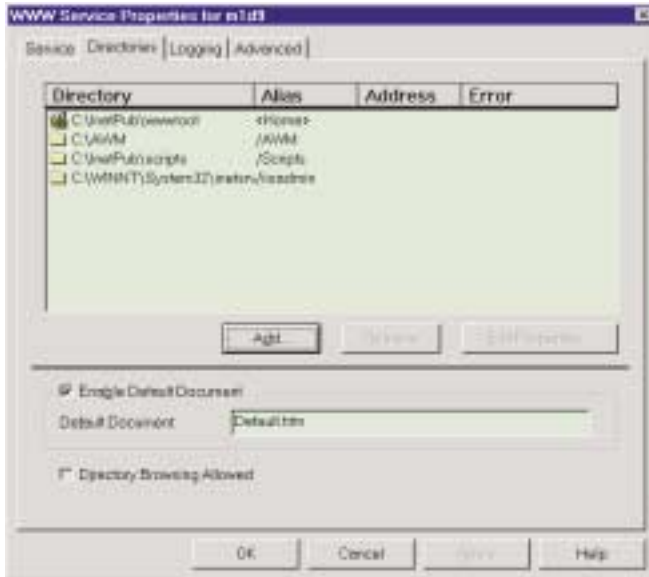

3. After adding the virtual directory, click the Execute checkbox and then click OK to save changes and exit.

