

**ASUS<sup>®</sup> SP97-XV**  
Pentium<sup>®</sup> ATX Motherboard

**USER'S MANUAL**

# USER'S NOTICE

---

No part of this manual, including the products and software described in it, may be reproduced, transmitted, transcribed, stored in a retrieval system, or translated into any language in any form or by any means, except documentation kept by the purchaser for backup purposes, without the express written permission of ASUSTeK COMPUTER INC. ("ASUS").

ASUS PROVIDES THIS MANUAL "AS IS" WITHOUT WARRANTY OF ANY KIND, EITHER EXPRESS OR IMPLIED, INCLUDING BUT NOT LIMITED TO THE IMPLIED WARRANTIES OR CONDITIONS OF MERCHANTABILITY OR FITNESS FOR A PARTICULAR PURPOSE. IN NO EVENT SHALL ASUS, ITS DIRECTORS, OFFICERS, EMPLOYEES OR AGENTS BE LIABLE FOR ANY INDIRECT, SPECIAL, INCIDENTAL, OR CONSEQUENTIAL DAMAGES (INCLUDING DAMAGES FOR LOSS OF PROFITS, LOSS OF BUSINESS, LOSS OF USE OR DATA, INTERRUPTION OF BUSINESS AND THE LIKE), EVEN IF ASUS HAS BEEN ADVISED OF THE POSSIBILITY OF SUCH DAMAGES ARISING FROM ANY DEFECT OR ERROR IN THIS MANUAL OR PRODUCT.

Product warranty or service will not be extended if: (1) the motherboard is repaired, modified or altered, unless such repair, modification or alteration is authorized in writing by ASUS; or (2) the serial number of the product is defaced or missing.

Products and corporate names appearing in this manual may or may not be registered trademarks or copyrights of their respective companies, and are used only for identification or explanation and to the owners' benefit, without intent to infringe.

- Intel, LANDesk, and Pentium are registered trademarks of Intel Corporation.
- IBM and OS/2 are registered trademarks of International Business Machines.
- Symbios is a registered trademark of Symbios Logic Corporation.
- Windows and MS-DOS are registered trademarks of Microsoft Corporation.
- Sound Blaster AWE32 and SB16 are trademarks of Creative Technology Ltd.
- Adobe and Acrobat are registered trademarks of Adobe Systems Incorporated.

The product name and revision number are both printed on the board itself. Manual revisions are released for each board design represented by the digit before and after the period of the manual revision number. Manual updates are represented by the third digit in the manual revision number.

For previous or updated manuals, BIOS, drivers, or product release information, contact ASUS at <http://www.asus.com.tw> or through any of the means indicated on the following page.

SPECIFICATIONS AND INFORMATION CONTAINED IN THIS MANUAL ARE FURNISHED FOR INFORMATIONAL USE ONLY, AND ARE SUBJECT TO CHANGE AT ANY TIME WITHOUT NOTICE, AND SHOULD NOT BE CONSTRUED AS A COMMITMENT BY ASUS. ASUS ASSUMES NO RESPONSIBILITY OR LIABILITY FOR ANY ERRORS OR INACCURACIES THAT MAY APPEAR IN THIS MANUAL, INCLUDING THE PRODUCTS AND SOFTWARE DESCRIBED IN IT.

**Copyright © 1997 ASUSTeK COMPUTER INC. All Rights Reserved.**

Product Name:	<b>ASUS SP97-XV</b>
Manual Revision:	<b>1.02</b>
Release Date:	<b>October 1997</b>

# ASUS CONTACT INFORMATION

---

## ASUSTeK COMPUTER INC.

### *Marketing Info*

Address: 150 Li-Te Road, Peitou, Taipei, Taiwan 112, ROC  
Telephone: +886-2-894-3447  
Fax: +886-2-894-3449  
Email: info@asus.com.tw

### *Technical Support*

Fax: +886-2-895-9254  
BBS: +886-2-896-4667  
Email: tsd@asus.com.tw  
WWW: www.asus.com.tw  
Gopher: gopher.asus.com.tw  
FTP: ftp.asus.com.tw/pub/ASUS

## ASUS COMPUTER INTERNATIONAL

### *Marketing Info*

Address: 721 Charcot Avenue, San Jose, CA 95131, USA  
Telephone: +1-408-474-0567  
Fax: +1-408-474-0568  
Email: info-usa@asus.com.tw

### *Technical Support*

BBS: +1-408-474-0569  
Email: tsd-usa@asus.com.tw  
WWW: www.asus.com

## ASUS COMPUTER GmbH

### *Marketing Info*

Address: Harkort Str. 25, 40880 Ratingen, BRD, Germany  
Telephone: 49-2102-445011  
Fax: 49-2102-442066  
Email: info-ger@asus.com.tw

### *Technical Support*

BBS: 49-2102-448690  
Email: tsd-ger@asus.com.tw  
Hotline: 49-2102-499712

# CONTENTS

---

<b>I. INTRODUCTION</b> .....	<b>7</b>
How this manual is organized .....	7
Item Checklist .....	7
<b>II. FEATURES</b> .....	<b>8</b>
Features of the ASUS SP97-XV Motherboard .....	8
Parts of the ASUS SP97-XV Motherboard .....	9
<b>III. INSTALLATION</b> .....	<b>10</b>
ASUS SP97-XV Motherboard Layout .....	10
Installation Steps .....	12
1. Jumpers .....	12
Jumper Settings .....	13
2. System Memory (SIMM & DIMM) .....	17
SIMM Memory Installation .....	18
DIMM Memory Installation Procedures: .....	19
3. Central Processing Unit (CPU) .....	21
4. Expansion Cards .....	22
Expansion Card Installation Procedure: .....	22
Assigning IRQs for Expansion Cards .....	22
Assigning DMA Channels for ISA Cards .....	23
5. External Connectors .....	24
Power Connection Procedures .....	31
<b>IV. BIOS SOFTWARE</b> .....	<b>32</b>
Support Software .....	32
Flash Memory Writer Utility .....	32
Main Menu .....	32
Advanced Feature Menu .....	33
Managing and Updating Your Motherboard's BIOS .....	34
6. BIOS Setup .....	35
Load Defaults .....	36
Standard CMOS Setup .....	36
Details of Standard CMOS Setup: .....	37
BIOS Features Setup .....	39
Details of BIOS Features Setup .....	39
Chipset Features Setup .....	41
Details of Chipset Features Setup .....	41
Power Management Setup .....	44
Details of Power Management Setup .....	44
PNP and PCI Setup .....	46
Details of PNP and PCI Setup .....	46
Load BIOS Defaults .....	48

# CONTENTS

---

Load Setup Defaults .....	48
Supervisor Password and User Password .....	49
IDE HDD Auto Detection .....	50
Save and Exit Setup .....	51
Exit Without Saving .....	51
<b>V. SUPPORT SOFTWARE .....</b>	<b>52</b>
Desktop Management Interface (DMI) .....	52
Introducing the ASUS DMI Configuration Utility .....	52
System Requirements .....	52
Using the ASUS DMI Configuration Utility .....	53
Notes .....	53
<b>VI. ASUS PCI SCSI Cards .....</b>	<b>55</b>
Symbios SCSI BIOS and Drivers .....	55
ASUS PCI-SC200 & PCI-SC860 SCSI Cards .....	55
Setting Up the ASUS PCI-SC200 & PCI-SC860 .....	56
Setting the INT Assignment for the ASUS PCI-SC200 .....	56
Terminator Requirements for SCSI Devices .....	56
Terminator Settings for the ASUS PCI-SC860 .....	57
Terminator Settings for the ASUS PCI-SC200 .....	57
SCSI ID Numbers for SCSI Devices .....	58
SCSI ID Priority .....	58
<b>VIDEO SOFTWARE USER'S MANUAL (with onboard VGA) ..</b>	<b>59</b>
<b>VIII. DOS UTILITY .....</b>	<b>61</b>
DOS Utility .....	61
1. SVGAUTL.EXE .....	61
<b>IX. SOFTWARE DRIVERS .....</b>	<b>68</b>
Software Drivers .....	68
1. Windows 3.1 .....	69
2. Windows 95 .....	75
5. Autodesk ADI 4.2 -Protected Mode .....	80
6. OS/2 V2.1 .....	86
7. OS/2 V3.0 (Warp) .....	87
8. Double Bytes OS/2 Warp .....	88

# FCC & DOC COMPLIANCE

---

## ***Federal Communications Commission Statement***

This device complies with FCC Rules Part 15. Operation is subject to the following two conditions:

- This device may not cause harmful interference, and
- This device must accept any interference received, including interference that may cause undesired operation.

This equipment has been tested and found to comply with the limits for a Class B digital device, pursuant to Part 15 of the FCC Rules. These limits are designed to provide reasonable protection against harmful interference in a residential installation. This equipment generates, uses and can radiate radio frequency energy and, if not installed and used in accordance with manufacturer's instructions, may cause harmful interference to radio communications. However, there is no guarantee that interference will not occur in a particular installation. If this equipment does cause harmful interference to radio or television reception, which can be determined by turning the equipment off and on, the user is encouraged to try to correct the interference by one or more of the following measures:

- Re-orient or relocate the receiving antenna.
- Increase the separation between the equipment and receiver.
- Connect the equipment to an outlet on a circuit different from that to which the receiver is connected.
- Consult the dealer or an experienced radio/TV technician for help.

**WARNING!** The use of shielded cables for connection of the monitor to the graphics card is required to assure compliance with FCC regulations. Changes or modifications to this unit not expressly approved by the party responsible for compliance could void the user's authority to operate this equipment.

## ***Canadian Department of Communications Statement***

This digital apparatus does not exceed the Class B limits for radio noise emissions from digital apparatus set out in the Radio Interference Regulations of the Canadian Department of Communications.

# I. INTRODUCTION

## How this manual is organized

This manual is divided into the following sections:

- I. Introduction:** Manual information and checklist
- II. Features:** Information and specifications concerning this product
- III. Installation:** Instructions on setting up the motherboard
- IV. BIOS Software:** Instructions on setting up the BIOS software
- V. Support Software:** Information on the included support software
- VI. ASUS SCSI Cards:** Installation of ASUS SCSI cards (optional)

## Item Checklist

Please check that your package is complete. If you discover damaged or missing items, please contact your retailer.

- (1) ASUS Motherboard
- (1) IDE ribbon cable for master and slave drives
- (1) Floppy ribbon cable for (1) 5.25inch floppy and (2) 3.5inch floppies
- (1) bag of spare jumpers
- (1) diskette of support drivers and utilities:
  - Flash Memory Writer utility to update the onboard programmable BIOS
  - Desktop Management Interface (DMI) utility
  - Readme files for descriptions and use of the files
  - Technical Support Form
- (1) User's Manual
- (1) video ribbon cable with bracket for the onboard VGA version only
- external infrared (IrDA) module (optional)
- ASUS PCI-SC200 Fast-SCSI or PCI-SC860 Ultra-Fast SCSI card (optional)

## II. FEATURES

---

### Features of the ASUS SP97-XV Motherboard

The ASUS SP97-XV motherboard is carefully designed for the demanding PC user who wants many features in a small package, namely:

- **SiS Chipset:** Features either SiS5582 or SiS5598 chipsets. The SiS5598 chipset has a built-in video controller and supports video shared memory from 1-4MB.
- **Versatile Processor Support:** Intel Pentium® 75–233MHz (P55C-MMX™, P54C/P54CS), IBM®/Cyrix® 6x86-PR166+ (Rev 2.7 or later), IBM®/Cyrix® 6x86MX™ (PR166 & faster), AMD-K5™ (PR75–PR133), AMD-K6™ (PR166 & faster).
- **Versatile Memory Support:** Is equipped with two DIMM sockets to support 8-128MB 168-pin 3.3Volt SDRAM/EDO memory modules up to 256MB. Is also equipped with four SIMM sockets to support 4-64MB 72-pin Fast Page Mode (FPM) or Extended Data Out (EDO) memory modules up to 256MB. **SIMMs and DIMMs cannot be used at the same time, damage may occur.**
- **Easy Installation:** Incorporates BIOS that supports autodetection of hard disk drives, PS/2 mouse, and Plug and Play devices to make setup of hard disk drives, expansion cards, and other devices virtually automatic.
- **ISA and PCI Expansion Slots:** Provides four 16-bit ISA slots and four 32-bit PCI slots
- **Super Multi-I/O:** Provides two high-speed UART-compatible serial ports and one parallel port with EPP and ECP capabilities.
- **Desktop Management Interface (DMI):** Supports DMI through BIOS, which allows hardware to communicate within a standard protocol creating a higher level of compatibility. (Requires DMI-enabled components.) (See section V)
- **PCI Bus Master IDE Controller:** Comes with an onboard Ultra DMA/33 Bus Master IDE controller with two connectors. Supports four IDE devices more than 8.4GB in two channels up to 33MB/sec IDE transfers and Enhanced IDE devices. Also supports PIO Modes 3 and 4 and Bus Master IDE DMA Mode 2. Includes integrated keyboard controller. Supports two of either 5.25- (360KB or 1.2KB) or 3.5-inch disk drives (720KB, 1.44MB, or 2.88MB). Supports Japanese “Floppy 3 mode” (3.5-inch disk drive: 1.2MB) and LS-120 floppy disk drives (3.5-inch disk drive: 120 MB, 1.44MB, 720K). BIOS supports IDE CD-ROM or SCSI device bootup.
- **Level 2 Cache:** Comes with onboard 512K Pipelined Burst SRAM.
- **IrDA Connector:** Supports an optional infrared module for wireless interface.
- **Symbios SCSI BIOS:** Supports optional ASUS SCSI controller cards through onboard firmware.
- **Performance:** 528MB/s data transfer rate using SDRAM, 33MB/s IDE transfer rate using Bus Master UltraDMA/33 IDE, concurrent PCI allows multiple PCI transfers
- **Compliance:** ACPI ready for advanced power management features and PC'97 for greater support.



# II. FEATURES

## Parts of the ASUS SP97-XV Motherboard

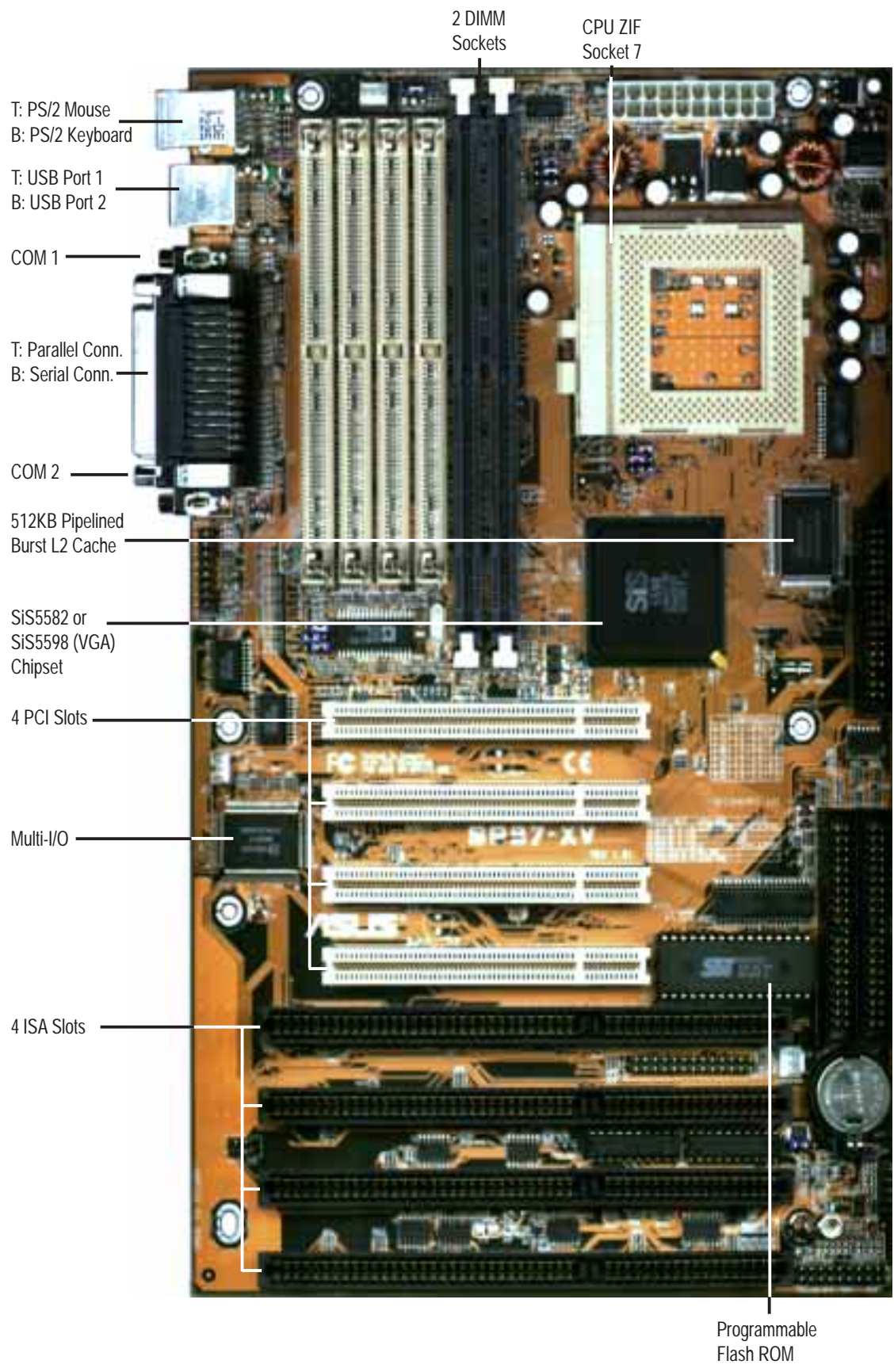

II. FEATURES  
(Motherboard Parts)

# III. INSTALLATION

## ASUS SP97-XV Motherboard Layout

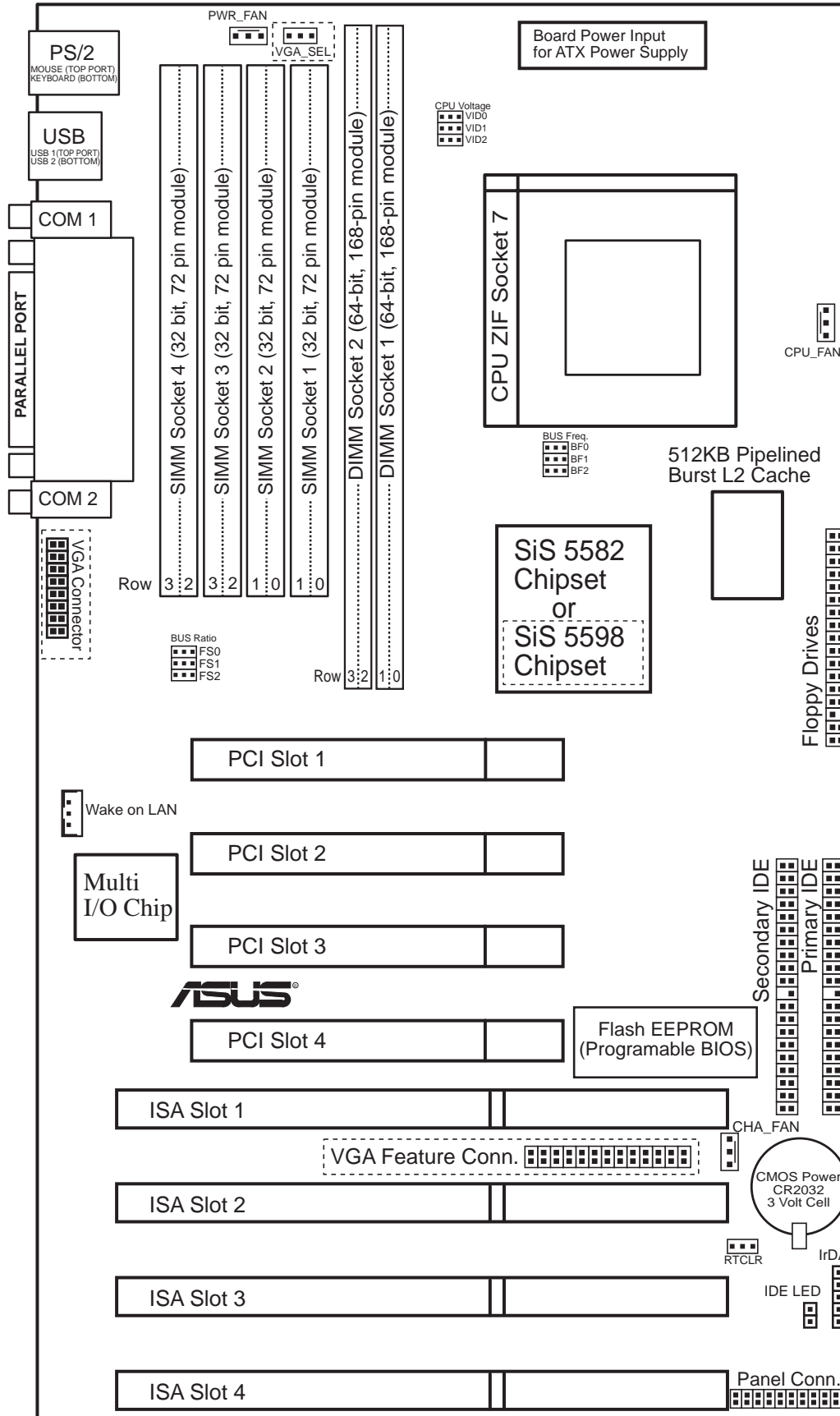

**NOTE:** Outlined components are available only with the onboard VGA version.

III. INSTALLATION  
(Motherboard Layout)

# III. INSTALLATION

---

## Jumpers

- |                       |       |  |
|-----------------------|-------|--|
| 1) RTCLR              | p. 13 | Real Time Clock RAM (Operation/Clear Data)   |
| 2) VGA_SEL (optional) | p. 14 | Onboard VGA Select (Disable/Enable)          |
| 3) FS0, FS1, FS2      | p. 14 | CPU External Clock (BUS) Frequency Selection |
| 4) BF0, BF1, BF2      | p. 14 | CPU:BUS Frequency Ratio                      |
| 5) VID0, 1, 2         | p. 16 | CPU Voltage Regulator Output Selection       |

## Expansion Slots

- |                     |       |                                       |
|---------------------|-------|---------------------------------------|
| 1) SIMM Sockets     | p. 17 | 72-Pin SIMM Memory Expansion Sockets  |
| 2) DIMM Sockets     | p. 17 | 168-Pin DIMM Memory Expansion Sockets |
| 3) CPU ZIF Socket 7 | p. 21 | Central Processing Unit (CPU) Socket  |
| 4) SLOT 1, 2, 3, 4  | p. 22 | 16-bit ISA Bus Expansion Slots        |
| 5) PCI 1, 2, 3, 4   | p. 22 | 32-bit PCI Bus Expansion Slots        |

## Connectors

- |                         |       |   |
|-------------------------|-------|---|
| 1) PS2KEYBOARD          | p. 24 | PS/2 Keyboard Connector (6-pin Female)              |
| 2) PS2MOUSE             | p. 24 | PS/2 Mouse Connector (6-pin Female)                 |
| 3) PRINTER              | p. 25 | Parallel (Printer) Port Connector (25-pin Female)   |
| 4) COM1, COM2           | p. 25 | Serial Port COM1 and COM2 (Two 9-pin Male)          |
| 5) USB                  | p. 25 | Universal Serial BUS Ports 1 & 2 (Two 4-pin Female) |
| 6) IR                   | p. 26 | Infrared Port Module Connector                      |
| 7) FLOPPY               | p. 26 | Floppy Drive Connector (34-pin Block)               |
| 8) Primary / Second IDE | p. 27 | Primary / Secondary IDE Connector (40-pin Blocks)   |
| 9) IDE_LED              | p. 27 | IDE LED Activity Light                              |
| 10) CHA, PWR, CPU_FAN   | p. 28 | Chassis, Power Supply, CPU Fan Power (3-pin Blocks) |
| 11) ATXPWR              | p. 28 | ATX Motherboard Power Connector (20-pin Block)      |
| 12) MSG LED (PANEL)     | p. 29 | System Message LED (2 pins)                         |
| 13) SMI (PANEL)         | p. 29 | SMI Switch Lead (2 pins)                            |
| 14) PWR SW (PANEL)      | p. 29 | ATX Power & Soft-Off Switch Lead (2 pins)           |
| 15) RESET (PANEL)       | p. 29 | Reset Switch Lead (2 pins)                          |
| 16) PWR LED (PANEL)     | p. 29 | System Power LED Lead (3 pins)                      |
| 17) KEYLOCK (PANEL)     | p. 29 | Keyboard Lock Switch Lead (2 pins)                  |
| 18) SPEAKER (PANEL)     | p. 29 | Speaker Output Connector (4 pins)                   |
| 19) VGACON (optional)   | p. 30 | Onboard VGA Connector (16 pins)                     |
| 20) FEATURE (optional)  | p. 30 | Onboard VGA Feature Connector (26 pins)             |







# III. INSTALLATION

## Installation Steps

Before using your computer, you must complete the following steps:

1. Set Jumpers on the Motherboard
2. Install System Memory
3. Install the Central Processing Unit (CPU)
4. Install Expansion Cards
5. Connect Ribbon Cables, Cabinet Wires, and Power Supply
6. Setup the BIOS Software

### 1. Jumpers

Several hardware settings are made through the use of jumper caps to connect jumper pins (JP) on the motherboard. See “Motherboard Layout” for locations of jumpers. The jumper settings will be described numerically such as [----], [1-2], [2-3] for no connection, connect pins 1&2, and connect pins 2&3 respectively. Pin 1 for our motherboards is always on top  or on the left  when holding the motherboard with the keyboard connector away from yourself. A “1” is written besides pin 1 on jumpers with three pins. The jumpers will also be shown graphically such as  to connect pins 1&2 and  to connect pins 2&3. Jumpers with two pins will be shown as  for Short (On) and  for Open (Off). For manufacturing simplicity, the jumpers may be sharing pins from other groups. Use the diagrams in this manual instead of following the pin layout on the board. Settings with two jumper numbers require that both jumpers be moved together. To connect the pins, simply place a plastic jumper cap over the two pins as diagramed.

**WARNING!** Computer motherboards, baseboards and components, such as SCSI cards, contain very delicate Integrated Circuit (IC) chips. To protect them against damage from static electricity, you should follow some precautions whenever you work on your computer.

1. Unplug your computer when working on the inside.
2. Use a grounded wrist strap before handling computer components. If you do not have one, touch both of your hands to a safely grounded object or to a metal object, such as the power supply case.
3. Hold components by the edges and try not to touch the IC chips, leads or connectors, or other components.
4. Place components on a grounded antistatic pad or on the bag that came with the component whenever the components are separated from the system.

# III. INSTALLATION

## Jumper Settings

### 1. Real Time Clock (RTC) RAM (RTCLR)

The CMOS RAM is powered by the onboard button cell battery. To clear the RTC data: (1) Turn off your computer and remove the AC power, (2) Move this jumper to “Clear Data,” (3) Move the jumper back to “Operation,” (4) Turn on your computer, (5) Hold down <Delete> during bootup and enter BIOS setup to re-enter user preferences.

#### Battery Test Jumper (RTCLR)

You can test the battery’s current by removing this jumper and attaching a current meter to the “Operation” pins.

**WARNING!** You must unplug the power cord to your power supply to ensure that there is no power to your motherboard. The CMOS RAM containing BIOS setup information *may* be cleared by this action. You *should* enter BIOS to “Load Setup Defaults” and re-enter any user information after removing and reapplying this jumper.

#### RTC RAM

Operation

Clear Data

#### RTCLR

[1-2] (Default)

[2-3] (momentarily)

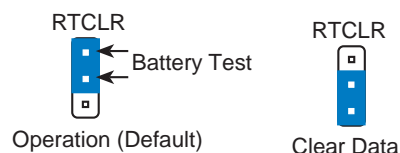
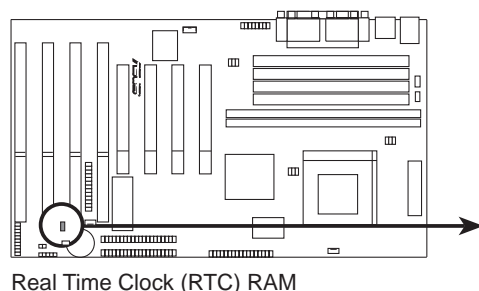

# III. INSTALLATION

## 2. VGA Setting (VGA\_SEL) (with onboard VGA version only)

These jumpers allow you to turn the onboard VGA on or off if necessary. The motherboard BIOS will automatically Enable or Disable the onboard VGA based on whether a VGA card is in the expansion bus. You need to disable the onboard VGA only if you have conflicts between the onboard VGA and a separate installed VGA expansion card within your operating system.

VGA_SEL	Setting
Enable	[2-3] (default)
Disable	[1-2]

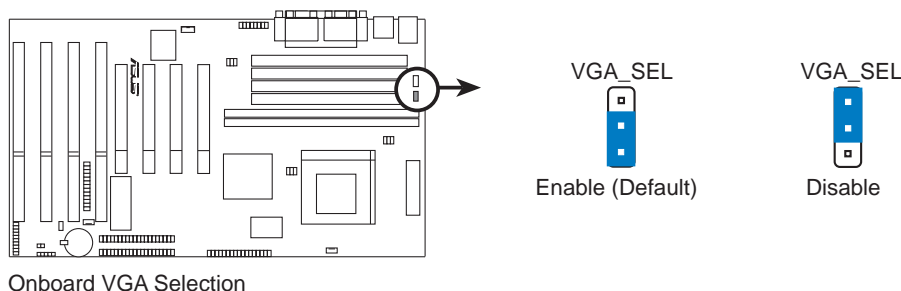

## 3. CPU External (BUS) Frequency Selection (FS0, FS1, FS2)

These jumpers tell the clock generator what frequency to send to the CPU. These allow the selection of the CPU's *External* frequency (or *BUS Clock*). The *BUS Clock* times the *BUS Ratio* equals the CPU's *Internal* frequency (the advertised CPU speed).

## 4. CPU to BUS Frequency Ratio (BF0, BF1, BF2)

These jumpers set the frequency ratio between the *Internal* frequency of the CPU and the *External* frequency (called the *BUS Clock*) within the CPU. These must be set together with the above jumpers *CPU External (BUS) Frequency Selection*.

Match the table's Ratio column to these CPU types:

	50MHz	55MHz	60MHz	66MHz	75MHz	83MHz
CPU A	1.5x(3/2)	2.0x(2/1)	2.5x(5/2)	3.0x(3/1)	----	----
CPU B	3.5x(7/2)	2.0x(2/1)	2.5x(5/2)	3.0x(3/1)	----	----
CPU C	3.0x(3/1)	2.0x(2/1)	1.0x(1/1)	----	----	----
CPU D	3.0x(3/1)	2.0x(2/1)	2.0x(2/1)	----	----	----
CPU E	3.5x(7/2)	2.0x(2/1)	2.5x(5/2)	3.0x(3/1)	4.0x(4/1)	(4.5x)(9/2)

CPU : BUS Frequency Ratio

**WARNING!** Frequencies above 66MHz exceed the specifications for the onboard Intel Chipset and are not guaranteed to be stable.

# III. INSTALLATION

Set the jumpers by the Internal speed of the Intel, AMD, IBM, or Cyrix CPU as follows:

CPU Model	Freq.	Ratio	(BUS Freq.)			(Freq. Ratio)			
			BUS F.	FS2	FS1	FS0	BF2	BF1	BF0
Intel Pentium P54C	166MHz	A-2.5x	66MHz	[2-3]	[1-2]	[2-3]	[----]	[2-3]	[2-3]
Intel Pentium P54C	150MHz	A-2.5x	60MHz	[2-3]	[2-3]	[1-2]	[----]	[2-3]	[2-3]
Intel Pentium P54C	133MHz	A-2.0x	66MHz	[2-3]	[1-2]	[2-3]	[----]	[1-2]	[2-3]
Intel Pentium P54C	120MHz	A-2.0x	60MHz	[2-3]	[2-3]	[1-2]	[----]	[1-2]	[2-3]
Intel Pentium P54C	100MHz	A-1.5x	66MHz	[2-3]	[1-2]	[2-3]	[----]	[1-2]	[1-2]
Intel Pentium P54C	90MHz	A-1.5x	60MHz	[2-3]	[2-3]	[1-2]	[----]	[1-2]	[1-2]
Intel Pentium P54C	75MHz	A-1.5x	50MHz	[2-3]	[2-3]	[2-3]	[----]	[1-2]	[1-2]
AMD-K5-PR133	100MHz	A-1.5x	66MHz	[2-3]	[1-2]	[2-3]	[----]	[1-2]	[1-2]
AMD-K5-PR120	90MHz	A-1.5x	60MHz	[2-3]	[2-3]	[1-2]	[----]	[1-2]	[1-2]
AMD-K5-PR100	100MHz	A-1.5x	66MHz	[2-3]	[1-2]	[2-3]	[----]	[1-2]	[1-2]
AMD-K5-PR90	90MHz	A-1.5x	60MHz	[2-3]	[2-3]	[1-2]	[----]	[1-2]	[1-2]
AMD-K5-PR75	75MHz	A-1.5x	50MHz	[2-3]	[2-3]	[2-3]	[----]	[1-2]	[1-2]
Intel Pentium P55C	233MHz	B-3.5x	66MHz	[2-3]	[1-2]	[2-3]	[----]	[1-2]	[1-2]
Intel Pentium P55C	200MHz	B-3.0x	66MHz	[2-3]	[1-2]	[2-3]	[----]	[2-3]	[1-2]
Intel Pentium P55C	166MHz	B-2.5x	66MHz	[2-3]	[1-2]	[2-3]	[----]	[2-3]	[2-3]
IBM/Cyrix 6x86MX-PR233	200MHz	B-3.0x	66MHz	[2-3]	[1-2]	[2-3]	[----]	[2-3]	[1-2]
IBM/Cyrix 6x86MX-PR200	166MHz	B-2.5x	66MHz	[2-3]	[1-2]	[2-3]	[----]	[2-3]	[2-3]
IBM/Cyrix 6x86MX-PR166	150MHz	B-2.5x	60MHz	[2-3]	[2-3]	[1-2]	[----]	[2-3]	[2-3]
*IBM/Cyrix 6x86-PR166+	133MHz	C-2.0x	66MHz	[2-3]	[1-2]	[2-3]	[----]	[1-2]	[2-3]
*IBM/Cyrix 6x86L-PR166+	133MHz	D-2.0x	66MHz	[2-3]	[1-2]	[2-3]	[----]	[1-2]	[2-3]
AMD-K6-PR233	233MHz	E-3.5x	66MHz	[2-3]	[1-2]	[2-3]	[----]	[1-2]	[1-2]
AMD-K6-PR200	200MHz	E-3.0x	66MHz	[2-3]	[1-2]	[2-3]	[----]	[2-3]	[1-2]
AMD-K6-PR166	166MHz	E-2.5x	66MHz	[2-3]	[1-2]	[2-3]	[----]	[2-3]	[2-3]

**\*NOTE:** The only IBM/Cyrix 6x86(L) (or M1) that is supported on this motherboard is rev 2.7 or later. Look on the underside of the CPU for the serial number. The number should read G8DC6620A or later.

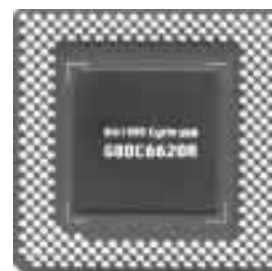

# III. INSTALLATION

## 5. Voltage Regulator Output Selection (VID0, 1, 2)

These jumpers set the voltage supplied to the CPU.

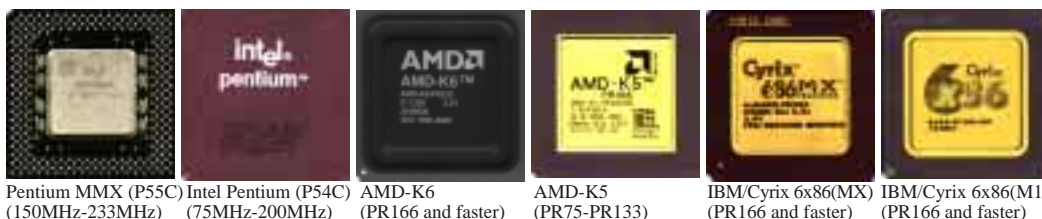

**WARNING!** Because CPU designs change rapidly, the table below is only intended as a simple guideline and thus may not be true for your CPU. Always refer to the CPU documentation for your CPU's voltage and then set the appropriate VID jumpers according to the illustration below.

Manufacturer	CPU Type	Single Plane	Dual Plane	VID2	VID1	VID0
Intel	P54C/P54CS	3.5V(VRE)	----	[2-3]	[2-3]	[1-2]
AMD	K5	3.5V(VRE)	----	[2-3]	[2-3]	[1-2]
IBM/Cyrix	6x86	3.5V(VRE)	----	[2-3]	[2-3]	[1-2]
Intel	P54C/P54CS	3.4V(STD)	----	[2-3]	[2-3]	[2-3]
AMD	K5	3.4V(STD)	----	[2-3]	[2-3]	[2-3]
AMD (.35micron)	K6-PR233	----	3.2V(Dual)	[1-2]	[2-3]	[2-3]
AMD (.35micron)	K6-166,200	----	2.9V(Dual)	[2-3]	[2-3]	[1-2]
IBM/Cyrix	6x86MX	----	2.9V(Dual)	[2-3]	[2-3]	[1-2]
Intel	P55C-MMX	----	2.8V(Dual)	[2-3]	[2-3]	[2-3]
AMD (.25micron)	K6-233,266,300	----	2.1V(Dual)	[2-3]	[2-3]	[1-2]

III. INSTALLATION  
(Jumpers)

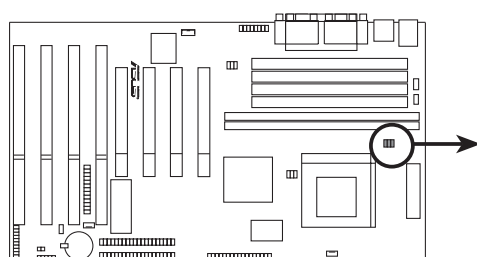

Voltage Regulator Output Selection

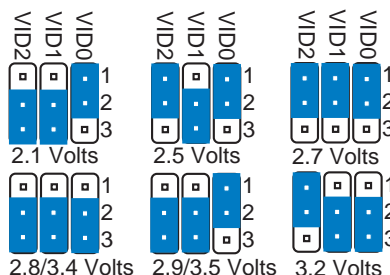

Note: Auto-voltage detection regulators allow some jumper settings to be the same for two voltages.



# III. INSTALLATION

## 2. System Memory (SIMM & DIMM)

This motherboard supports four 72-pin, 32-bit SIMMs (Single Inline Memory Modules) of 4, 8, 16, 32, or 64MB to form a memory size between 8MB to 256MB. The SIMMs can be either 60ns or 70ns Fast Page Mode (FPM) (Asymmetric or Symmetric), or Enhanced Data Out (EDO) (BEDO & Parity are not supported). SIMMs must be installed in pairs so that each Row (see *Map of Motherboard* for Row locations) contains 64-bits of the same size and type of memory chips. One side (with memory chips) of the SIMM module takes up half a Row on the motherboard.

Dual Inline Memory Modules (DIMM's) can be used when the SIMM sockets are not used. Two sockets are available for **3.3Volt** (power level) Unbuffered Synchronous DRAMs (SDRAM) or EDO DRAM of either 8, 16, 32, 64, or 128MB to form a memory size between 8MB to 256MB. One side (with memory chips) of the DIMM module takes up one Row on the motherboard.

**IMPORTANT: Memory speed setup is required through "Auto Configuration" in BIOS Chipset Setup of the BIOS SOFTWARE. If both 60ns and 70ns memory are used, set "Auto Configuration" to 70ns. Do not use memory modules with more than 24 chips per module. Modules with more than 24 chips exceed the design specifications of the memory subsystem and will be unstable.**

Memory Socket	SIMM Memory Module		Total Memory
SIMM Sockets 1&2 (Rows 0 & 1)	4MB, 8MB, 16MB, 32MB, 64MB 72-pin FPM or EDO SIMM (DIMM Sockets must be empty)	x2	
SIMM Sockets 3&4 (Rows 2 & 3)	4MB, 8MB, 16MB, 32MB, 64MB 72-pin FPM or EDO SIMM (DIMM Sockets must be empty)	x2	
	Total System Memory (Max 256MB)	=	

**WARNING!** Do not install both SIMMs and DIMMs at the same time or else you will burn your memory. Mixing SIMMs and DIMMs require 5.0Volt (signal level) tolerant memory chips which are currently unavailable.

Memory Socket	DIMM Memory Module		Total Memory
DIMM Socket 1 (Rows 0 & 1)	8MB, 16MB, 32MB, 64MB, 128MB 168-pin SDRAM or EDO DIMM (SIMM Sockets must be empty)	x1	
DIMM Socket 2 (Rows 2 & 3)	8MB, 16MB, 32MB, 64MB, 128MB 168-pin SDRAM or EDO DIMM (SIMM Sockets must be empty)	x1	
	Total System Memory (Max 256MB)	=	

# III. INSTALLATION

## *SIMM Memory Installation*

1. The SIMM memory modules will only fit in one orientation as shown because of a safety tab on one end of the SIMM sockets, which requires the notched end of the SIMM memory modules.

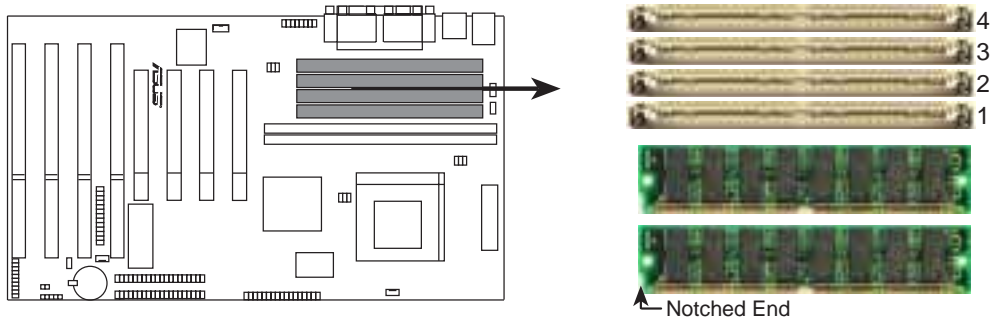

### **72 Pin SIMM Sockets**

2. Press the memory module firmly into place starting from a 45 degree angle making sure that all the contacts are aligned with the socket.
3. With your finger tips, rock the memory module into a vertical position so that it clicks into place.

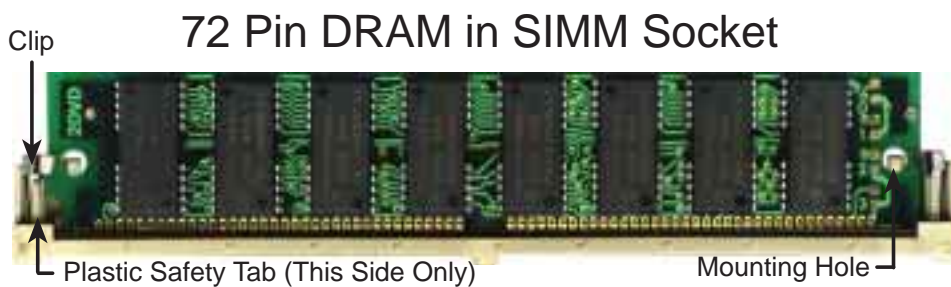

4. The plastic guides should go through the two mounting holes on the sides and the support clips should snap on the other side.
5. To release the memory module, push both support clips outward and rock the module out of the support clips.

# III. INSTALLATION

## *DIMM Memory Installation Procedures:*

Insert the module(s) as shown. Because the number of pins are different on either side of the breaks, the module will only fit in the orientation as shown. DRAM SIMM modules have the same pin contact on both sides. SDRAM DIMM modules have different pin contact on each side and therefore have a higher pin density.

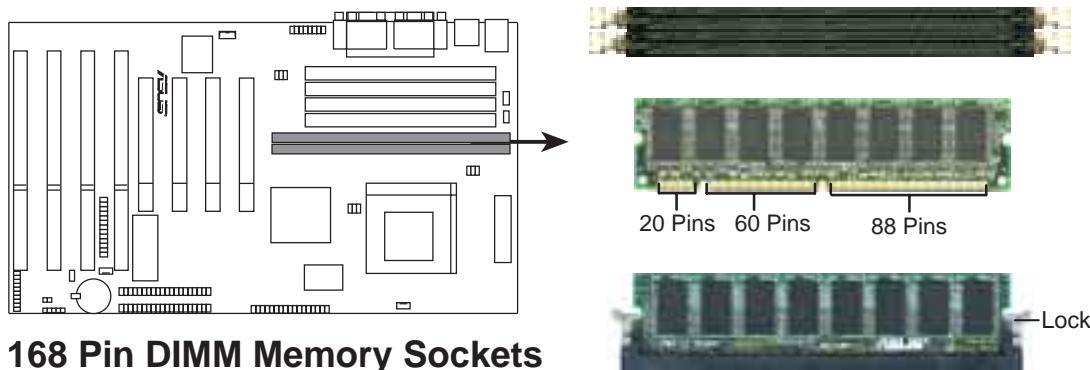

**168 Pin DIMM Memory Sockets**

The Dual Inline Memory Module (DIMM) memory modules must be 3.3Volt Unbuffered Synchronous DRAM (SDRAM) or Extended Data Output (EDO) . You can identify the type of DIMM module by the illustration below:

### 168-Pin DIMM Notch Key Definitions (3.3V)

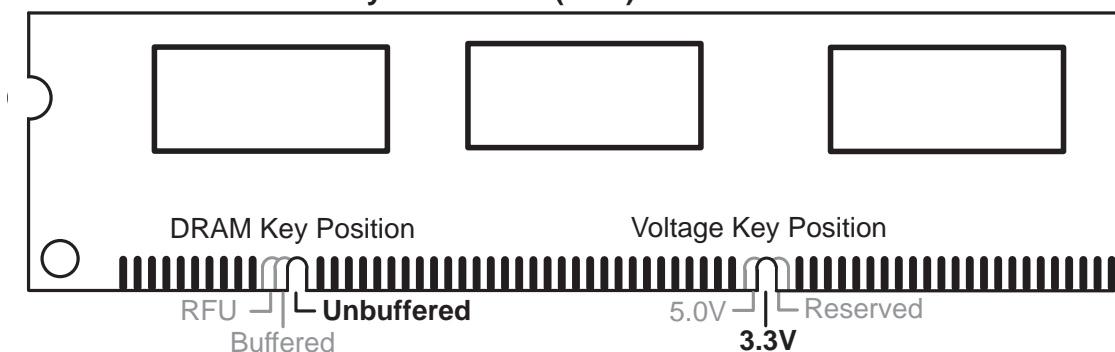

The notch on the DIMM module will shift between left, center, or right to identify the type and also to prevent the wrong type to be inserted into the DIMM slot on the motherboard. You must ask your retailer for the specifications before purchasing. Four clock signals are supported on this motherboard.

III. INSTALLATION  
(System Memory)

# III. INSTALLATION

---

(This page was intentionally left blank)



# III. INSTALLATION

## 3. Central Processing Unit (CPU)

The motherboard provides a 321-pin ZIF Socket 7 that is backwards compatible with ZIF Socket 5 processors. The CPU that came with the motherboard should have a fan attached to it to prevent overheating. If this is not the case then purchase a fan before you turn on your system.

**WARNING!** Without a fan circulating air on the CPU, the CPU can overheat and cause damage to both the CPU and the motherboard.

To install a CPU, first turn off your system and remove its cover. Locate the ZIF socket and open it by first pulling the lever sideways away from the socket then upwards to a 90-degree right angle. Insert the CPU with the correct orientation as shown. Use the notched corner of the CPU with the white dot as your guide. The white dot should point towards the end the of the lever. Notice that there is a blank area where one hole is missing from that corner of the square array of pin holes and a “1” printed on the motherboard next to that corner. Because the CPU has a corner pin for three of the four corners, the CPU will only fit in the one orientation as shown. The picture is for reference only; you should have a CPU fan that will cover the face of the CPU. With the added weight of the CPU fan, no force is required to insert the CPU. Once completely inserted, hold down on the fan and close the socket’s lever.

**IMPORTANT:** You must set jumpers for “CPU to BUS Frequency Ratio” and jumpers for “BUS Frequency Selection” depending on the CPU that you install.

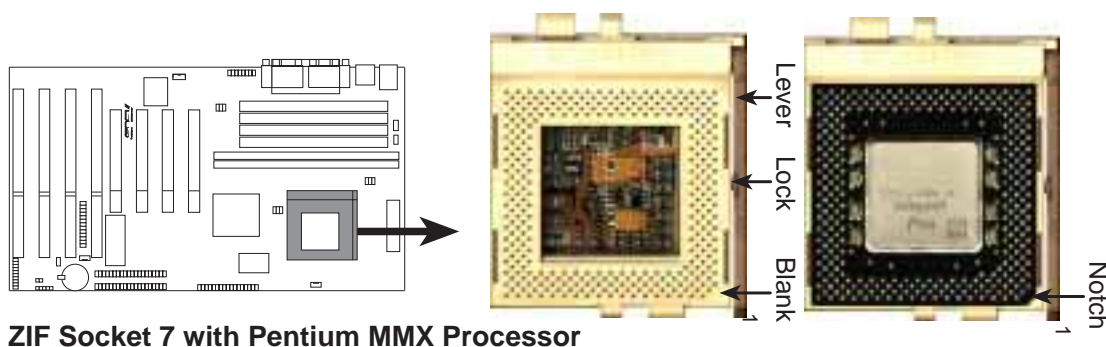

ZIF Socket 7 with Pentium MMX Processor

# III. INSTALLATION

---

## 4. Expansion Cards

**WARNING!** Make sure that you unplug your power supply when adding or removing expansion cards or other system components. Failure to do so may cause severe damage to both your motherboard and expansion cards.

First read your expansion card documentation on any hardware and software settings that may be required to setup your specific card.

**NOTE:** PCI Slot 4 has a MediaBus extension which allows the installation of a PCI card or a MediaBus card (optional multifunctional card) but not both.

### *Expansion Card Installation Procedure:*

1. Read the documentation for your expansion card.
2. Set any necessary jumpers on your expansion card.
3. Remove your computer system's cover.
4. Remove the bracket on the slot you intend to use. Keep the bracket for possible future use.
5. Carefully align the card's connectors and press firmly.
6. Secure the card on the slot with the screw you removed in step 4.
7. Replace the computer system's cover.
8. Setup the BIOS if necessary  
(such as "IRQ xx Used By ISA: Yes" in PNP AND PCI SETUP)
9. Install the necessary software drivers for your expansion card.

### *Assigning IRQs for Expansion Cards*

Some expansion cards need to use an IRQ to operate. Generally an IRQ must be exclusively assigned to one use. In a standard design there are 16 IRQs available but most of them are already in use by parts of the system which leaves 6 free for expansion cards.

Both ISA and PCI expansion cards may need to use IRQs. System IRQs are available to cards installed in the ISA expansion bus first, and any remaining IRQs are then used by PCI cards. Currently, there are two types of ISA cards.

# III. INSTALLATION

---

The original ISA expansion card design, now referred to as “Legacy” ISA cards, requires that you configure the card’s jumpers manually and then install it in any available slot on the ISA bus. You may use Microsoft’s Diagnostic (MSD.EXE) utility included in the Windows directory to see a map of your used and free IRQs. For Windows 95 users, the “Control Panel” icon in “My Computer,” contains a “System” icon which gives you a “Device Manager” tab. Double clicking on a specific device give you “Resources” tab which shows the Interrupt number and address. Make sure that no two devices use the same IRQs or your computer will experience problems when those two devices are in use at the same time.

To simplify this process this motherboard has complied with the Plug and Play (PNP) specification which was developed to allow automatic system configuration whenever a PNP-compliant card is added to the system. For PNP cards, IRQs are assigned automatically from those available.

If the system has both Legacy and PNP ISA cards installed, IRQs are assigned to PNP cards from those not used by Legacy cards. The PCI and PNP configuration of the BIOS setup utility can be used to indicate which IRQs are being used by Legacy cards. For older Legacy cards that does not work with the BIOS, you can contact your vendor for an ISA Configuration Utility.

An IRQ number is automatically assigned to PCI expansion cards after those used by Legacy and PNP ISA cards. In the PCI bus design, the BIOS automatically assigns an IRQ to a PCI slot that has a card in it that requires an IRQ. To install a PCI card, you need to set something called the INT (interrupt) assignment. Since all the PCI slots on this motherboard use an INTA #, be sure that the jumpers on your PCI cards are set to INT A.

## *Assigning DMA Channels for ISA Cards*

Some ISA cards, both legacy and PnP, may also need to use a DMA (Direct Memory Access) channel. DMA assignments for this motherboard are handled the same way as the IRQ assignment process described earlier. You can select a DMA channel in the PCI and PnP configuration section of the BIOS Setup utility.

**IMPORTANT:** To avoid conflicts, reserve the necessary IRQs and DMAs for legacy ISA cards (under PNP AND PCI SETUP of the BIOS SOFTWARE, choose *Yes* in *IRQ xx Used By ISA* and *DMA x Used By ISA* for those IRQs and DMAs you want to reserve).

# III. INSTALLATION

## 5. External Connectors

**WARNING!** Some pins are used for connectors or power sources. These are clearly separated from jumpers in “Map of the Motherboard.” Placing jumper caps over these will cause damage to your motherboard.

**IMPORTANT:** Ribbon cables should always be connected with the red stripe on the Pin 1 side of the connector. The four corners of the connectors are labeled on the motherboard. Pin 1 is the side closest to the power connector on hard drives and floppy drives. IDE ribbon cable must be less than 18in. (46cm), with the second drive connector no more than 6in. (15cm) from the first connector.

### 1. PS/2 Keyboard Connector (6-pin Female)

This connection is for a standard keyboard using an PS/2 plug (mini DIN). **This connector will not allow standard AT size (large DIN) keyboard plugs. You may use a DIN to mini DIN adapter on standard AT keyboards.**



PS/2 Keyboard (6-pin Female)

### 2. PS/2 Mouse Connector (6-pin Female)

The system will direct IRQ12 to the PS/2 mouse if one is detected. If not detected, expansion cards can use IRQ12. See “PS/2 Mouse Control” in BIOS Features Setup of the BIOS SOFTWARE.

PS/2 Mouse (6-pin Female)





# III. INSTALLATION

## 3. Parallel Printer Connector (25-pin Female)

You can enable the parallel port and choose the IRQ through “Onboard Parallel Port” in Chipset Features Setup of the BIOS SOFTWARE. **NOTE:** Serial printers must be connected to the serial port.

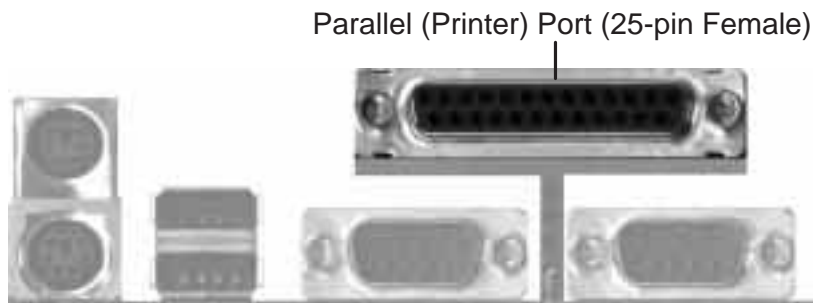

## 4. Serial Port COM1 and COM2 Connectors (Two 9-pin Male)

The two serial ports can be used for pointing devices or other serial devices. See “Onboard Serial Port” in Chipset Features Setup of the BIOS SOFTWARE.

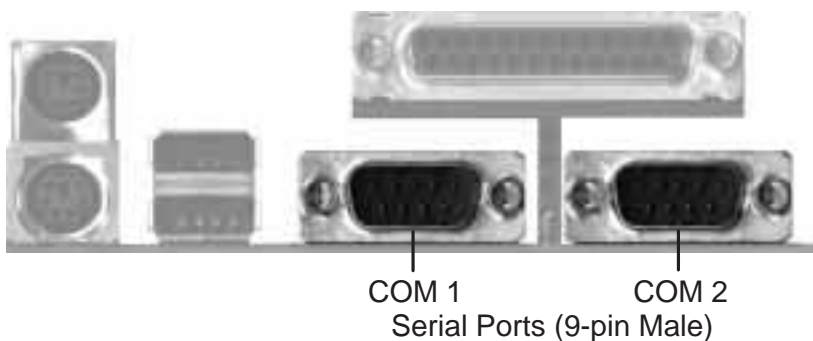

## 5. Universal Serial BUS Ports 1 & 2 (Two 4-pin Female Sockets)

Two USB ports are available for connecting USB devices.

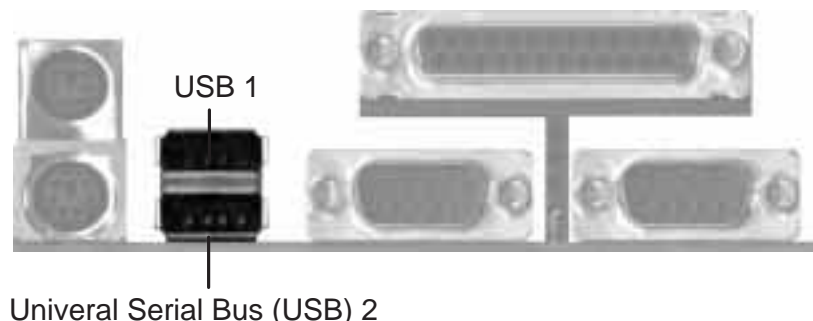

# III. INSTALLATION

## 6. IrDA / Fast IR-Compliant infrared module connector (6-pin IR)

This connector supports the optional wireless transmitting and receiving infrared module. This module mounts to a small opening on system cases that support this feature.

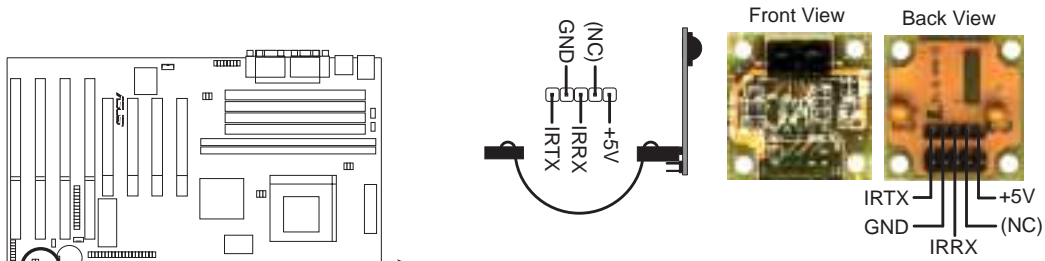

**Infrared Module Connector**

For the infrared feature to be available, you must connect an optional Infrared module to the motherboard.

## 7. Floppy Disk Drive Connector (34-1pin FLOPPY)

This connector supports the provided floppy drive ribbon cable. After connecting the single end to the board, connect the two plugs on the other end to the floppy drives. **(Pin 5 is removed to prevent inserting in the wrong orientation when using ribbon cables with pin 5 plugged).**

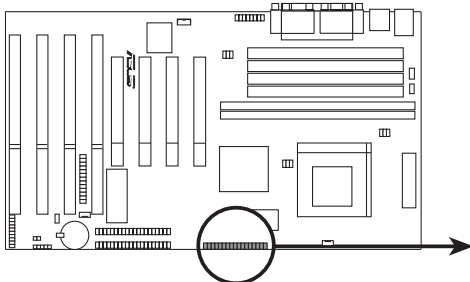

**Floppy Disk Drive Connector**

**NOTE:** Orient the red stripe to Pin 1

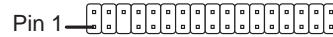

# III. INSTALLATION

## 8. Primary / Secondary IDE connectors (Two 40-1pin IDE)

These connectors support the provided IDE hard disk ribbon cable. After connecting the single end to the board, connect the two plugs at the other end to your hard disk(s). If you install two hard disks, you must configure the second drive to Slave mode by setting its jumper accordingly. Please refer to the documentation of your hard disk for the jumper settings. **(Pin 20 is removed to prevent inserting in the wrong orientation when using ribbon cables with pin 20 plugged).**

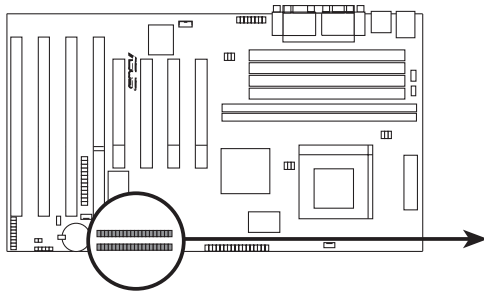

**NOTE:** Orient the red stripe to Pin 1

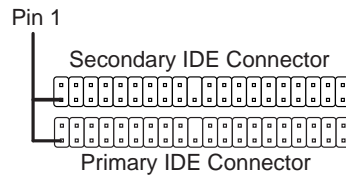

### IDE Connectors

## 9. IDE activity LED (4-1pin IDE\_LED)

This connector supplies power to the cabinet's IDE activity LED. Read and write activity by devices connected to the Primary or Secondary IDE connectors will cause the LED to light up.

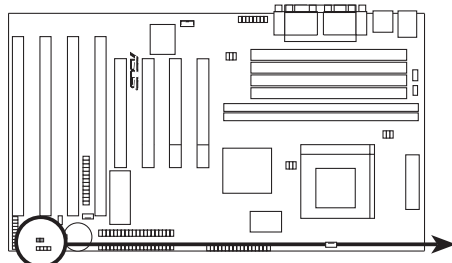

**TIP:** If the case-mounted LED does not light, try reversing the 2-pin plug.

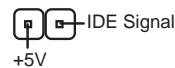

### IDE Activity LED

# III. INSTALLATION

## 10. CPU, Chassis, and Power Supply Fan Connectors (3-pin)

These connectors support cooling fans of 500mAMP (6WATT) or less.

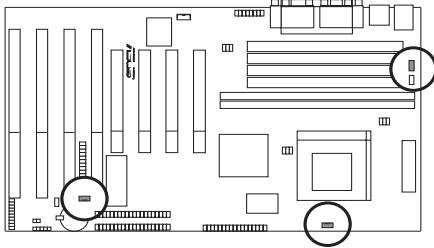

Power Supply Fan Power,  
CPU Fan Power,  
Chassis Fan Power



**12Volt Cooling Fan Power**

## 11. ATX Power Supply Connector (20-pin ATXPWR)

This connector connects to a ATX power supply. The plug from the power supply will only insert in one orientation because of the different hole sizes. Find the proper orientation and push down firmly making sure that the pins are aligned.

**IMPORTANT:** Be sure that the ATX power supply can take at least 10mAmp load on the 5volt standby lead (5VSB). You may experience difficulty in powering on your system without this.

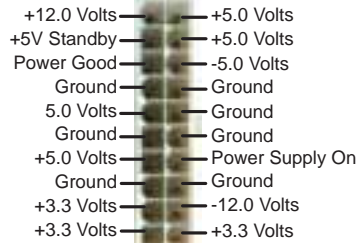
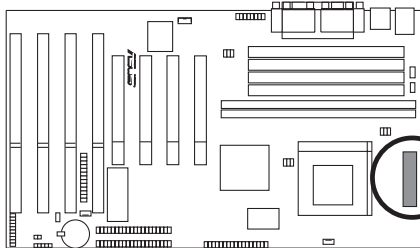

**ATX Power Connector**

# III. INSTALLATION

## 12. Message LED Lead (MSG LED)

This indicates whether a message has been received from a fax/modem. The LED will remain lit when there is no signal and blink when there is data transfer or waiting in the inbox).

## 13. SMI Suspend Switch Lead (SMI)

This allows the user to manually place the system into a suspend mode or “Green” mode where system activity will be instantly decreased to save electricity and expand the life of certain components when the system is not in use. This 2-pin connector (see the figure below) connects to the case-mounted suspend switch. If you do not have a switch for the connector, you may use the “Turbo Switch” since it does not have a function. SMI is activated when it detects a *short to open* moment and therefore leaving it shorted will not cause any problems. May require one or two pushes depending on the position of the switch. Wake-up can be controlled by settings in the BIOS but the keyboard will always allow wake-up (the SMI lead cannot wake-up the system).

## 14. ATX Power Switch / Soft Power Switch (PWR SW)

The system power is controlled by a momentary switch connected to this lead. Pushing the button once will switch the system between ON and SLEEP. Pushing the switch while in the ON mode for more than 4 seconds will turn the system off. The system power LED shows the status of the system’s power.

## 15. Reset Switch Lead (RESET)

This 2-pin connector connects to the case-mounted reset switch for rebooting your computer without having to turn off your power switch. This is a preferred method of rebooting in order to prolong the life of the system’s power supply.

## 16. System Power LED (PWR LED)

This 3-pin connector connects the system power LED, which lights when the system is powered on and blinks when it is in sleep mode.

## 17. Keyboard Lock Switch Lead (KEYLOCK, 2 pins)

This 2-pin connector connects to the case-mounted keyboard lock switch to allow keyboard locking.

## 18. Speaker Connector (SPEAKER)

This 4-pin connector connects to the case-mounted speaker.

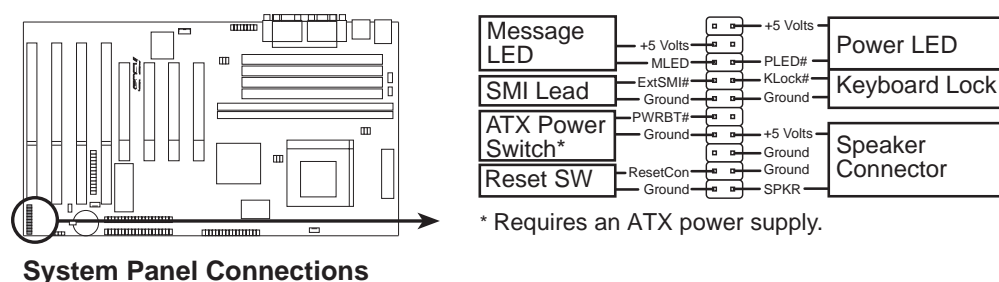

# III. INSTALLATION

## 19. VGA Connector (VGACON, 16 pins) (with onboard VGA version only)

This connector, available only on motherboards with the SiS5598 chipset, supports the provided video or monitor cable with mounting bracket. Connect the cable to this connector and mount the bracket to the case on a free expansion slot. Set VGA\_SEL jumper to *Enable* before using this connector.

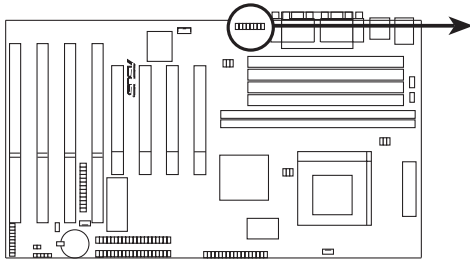

VGA (Monitor) Connector

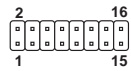

Orient the red stripe on the monitor cable with pin 1

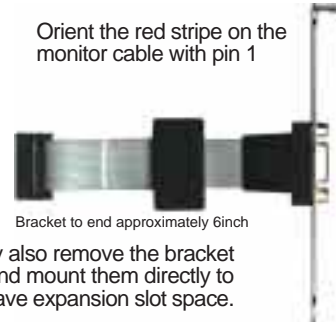

Bracket to end approximately 6inch

**TIP:** You may also remove the bracket connectors and mount them directly to the case to save expansion slot space.

## 20. Video Feature Connector (26 pins) (with onboard VGA version only)

This connector is used for third-party video accessories such as video capture cards or television tuners.

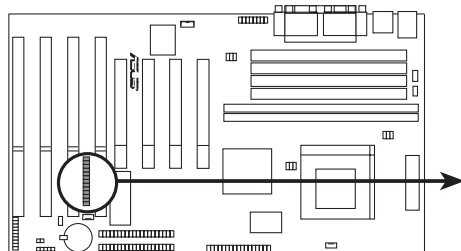

Video Feature Connector



# III. INSTALLATION

---

## Power Connection Procedures

1. After all jumpers and connections are made, close the system case cover.
  2. Make sure that all switches are off (in some systems, marked with ○).
  3. Connect the power supply cord into your computer's power supply.
  4. Connect the power cord into a power outlet that is equipped with a surge protector.
  5. You may then turn on your devices in the following order:
    - a. Your monitor
    - b. External SCSI devices (starting with the last device in the chain)
    - c. Your system power. For ATX power supplies, you need to switch on the power supply as well as press the ATX power switch on the front of the case.
  6. The power LED on the front panel of the system case will light. For ATX power supplies, the system LED will light when the ATX power switch is pressed. The monitor LED may light up after the system's if it complies with "Green" standards or if it has a power standby feature. The system will then run power-on tests. While the tests are running, additional messages will appear on the screen. If you do not see anything within 30 seconds from the time you turn on the power, the system may have failed a power-on test. Recheck your jumper settings and connections or call your retailer for assistance.
  7. During power-on, press <Delete> to enter the BIOS setup. Follow the instructions on the next section, "BIOS SOFTWARE."
- \* **Powering Off Your Computer:** You must first exit or shut down your operating system before switching off the power switch. For ATX power supplies, you can press the ATX power switch after exiting or shutting down your operating system. For Windows 95 users, you can click **Shut down the computer?** from the **Start** button and the system will give three quick beeps after about 30 seconds and power off after Windows shuts down.

**NOTE:** The message, **It's now safe to turn off your computer**, will not be shown in Windows 95 when using shut down with ATX power supplies.

# IV. BIOS SOFTWARE

## Support Software

**FILELIST.TXT** – View this file to see the files included in the support software.

**PFLASH.EXE** – This is the Flash Memory Writer utility that updates the BIOS by uploading a new BIOS file to the programmable flash ROM chip on the motherboard. To determine the BIOS version, check the last four numbers of the code displayed on the upper left-hand corner of your screen during bootup. Larger numbers represent a newer BIOS file.

**NOTE:** A binary BIOS file is no longer included with the support software. Save the motherboard's BIOS file to a floppy disk as soon as your system is operational. See "Flash Memory Writer Utility" in this section to "Save Current BIOS to File."

## Flash Memory Writer Utility

```
ASUSTek PNP BIOS
FLASH MEMORY WRITER V1.5
Copyright (C) 1995, ASUSTek COMPUTER INC.

Flash Type -- SST 29EE010
Current BIOS Revision: #401A0-xxxx
Choose one of the following:
1. Save Current BIOS To File
2. Update BIOS Main Block From File
3. Advanced Feature

Enter Choice: [1]

Press ESC To Exit
```

xxxx denotes the current BIOS version stored in the Flash EPROM

**IMPORTANT:** Flash Type may also be "INTEL 28F001BXT." If "unknown" is shown after "Flash type --," then this ROM chip is not programmable or not supported with the PnP BIOS and therefore cannot be programmed by the Flash Memory Writer.

### Main Menu

#### 1. Save Current BIOS To File (Perform as soon as system is operational)

This option allows you to copy the contents of the Flash memory chip onto a disk. This gives you a backup copy of the original motherboard BIOS in case you need to reinstall it.

**Create a system disk by typing `FORMAT A:/S` on the DOS prompt (do not create "AUTOEXEC.BAT" and "CONFIG.SYS"), then save the PFLASH.EXE file and the BIOS to the system disk.**



# IV. BIOS SOFTWARE

---

## 2. Update BIOS Main Block From File

This option updates the BIOS from a file on the disk. This can either be a new file or a backup file created by the “Save Current BIOS to File” option. This will not update the Boot Block if the Boot Block is different. You will be prompted with the following if advanced features if necessary.

```
Boot Block of New BIOS is different from old one !!!  
Please Use 'Advanced Feature' to flash whole bios !!!
```

## 3. Advanced Feature

Selecting this option brings up the Advanced Feature screen for clearing the PnP configuration record and updating the motherboard BIOS.

### *Advanced Feature Menu*

```
Advanced Feature  
  
Flash Type -- SST 29EE010  
Current BIOS Revision: #401A0-xxxx  
Choose one of the following:  
1. Clear PNP ESCD Parameter Block  
2. Update BIOS Including Boot Block and ESCD  
  
Enter Choice: [2]  
  
Press ESC To Return To Main Menu
```

xxxx denotes the current BIOS version stored in the Flash EPROM

### 1. Clear PNP ESCD Parameter Block

This option erases the Plug-and-Play (PnP) configuration record.

### 2. Update BIOS Including Boot Block and ESCD

This option updates the Boot Block, the motherboard BIOS and the PnP ESCD Parameter Block from a new BIOS file.

**NOTE:** “Update BIOS Main Block from File” and “Update BIOS Including Boot Block and ESCD” require that the system is running in real mode. This utility will not operate if the system is under protected mode or virtual mode. You must boot from a system floppy disk without the “AUTOEXEC.BAT” and “CONFIG.SYS” files.

# IV. BIOS SOFTWARE

---

## Managing and Updating Your Motherboard's BIOS

### Upon First Use of the Computer System

1. Create a bootable system floppy diskette by typing [FORMAT A:/S] from the DOS prompt without creating "AUTOEXEC.BAT" and "CONFIG.SYS" files.
2. Copy PFLASH.EXE to your new diskette.
3. Run PFLASH.EXE from your new diskette and select option 1 "Save Current BIOS to File." Enter the "Current BIOS Revision:" for the file name.

### Updating BIOS Procedures (only when necessary)

**IMPORTANT:** If "unknown" is displayed after **Flash Type --**, the memory chip is not programmable or is not supported with the PnP BIOS and therefore cannot be programmed by the Flash Memory Writer utility.

1. Download an updated ASUS BIOS file from the Internet (WWW or FTP) or a BBS (Bulletin Board Service) (see ASUS CONTACT INFORMATION on page 3 for details) and save to the disk you created earlier.
2. Turn off your computer..
3. Boot from the disk you created earlier.
4. At the "A:\\" prompt, type PFLASH and then press <Enter>.
5. Enter 2 "Update BIOS Main Block From File" from the Main Menu or option 2 "Update BIOS Including Boot Block and ESCD" from the Advanced Features Menu if prompted by option 2 of the Main Menu.
6. The program displays a second screen prompting you for the name of the BIOS file. Type in the complete file name and extension of the new BIOS, and then press <Enter>. The utility then updates the BIOS file from disk.

**WARNING!** If you encounter problems while updating the new BIOS, DO NOT turn off your system since this might prevent your system from booting up. Just repeat the process, and if the problem still persists, update the original BIOS file you saved to disk above. If the Flash Memory Writer utility was not able to successfully update a complete BIOS file, your system may not be able to boot up. If this happens, your system will need service.

7. After successfully updating the new BIOS file, exit the Flash Memory Writer utility and then turn off your system.
8. Turn on your computer and press <Delete> to enter BIOS setup. You must select "Setup Default" to effect the new BIOS, after which you may set the other items from the Main Menu.

# IV. BIOS SOFTWARE

## 6. BIOS Setup

The motherboard supports two programmable Flash ROM chips: 5 volts and 12 volts. Either of these memory chips can be updated when BIOS upgrades are released. Use the Flash Memory Writer utility to download the new BIOS file into the ROM chip as described in detail in this section.

All computer motherboards provide a Setup utility program for specifying the system configuration and settings. If your motherboard came in a computer system, the proper configuration entries may have already been made. If so, run the Setup utility, as described later, and take note of the configuration settings for future reference, in particular, the hard disk specifications.

If you are installing the motherboard, reconfiguring your system or you receive a Run Setup message, you will need to enter new setup information. This section describes how to configure your system using this utility.

The BIOS ROM of the system stores the Setup utility. When you turn on the computer, the system provides you with the opportunity to run this program. This appears during the Power-On Self Test (POST). Press <Delete> to call up the Setup utility. If you are a little bit late pressing <Delete>, POST will continue with its test routines, thus preventing you from calling up Setup. If you still need to call Setup, reset the system by pressing <Ctrl> + <Alt> + <Delete>, or by pressing the Reset button on the system case. You can also restart by turning the system off and then back on again. Do this only, however, if the first two methods fail.

When you run Setup, the CMOS SETUP UTILITY main program screen will appear with the following options:



# IV. BIOS SOFTWARE

## Load Defaults

**Load BIOS Defaults** loads the minimized settings for troubleshooting. **Load Setup Defaults**, on the other hand, is for loading optimized defaults for regular use. Choosing defaults at this level will modify all applicable settings.

A section at the bottom of the preceding screen displays the control keys for this screen. Take note of these keys and their respective uses. Another section just below the control keys section displays information on the currently highlighted item in the list.

## Standard CMOS Setup

**Standard CMOS Setup** allows you to record some basic system hardware configuration and set the system clock and error handling. If the motherboard is already installed in a working system, you will not need to select this option anymore. However, if the configuration stored in the CMOS memory on the board gets lost or damaged, or if you change your system hardware configuration, you will need to re-specify the configuration values. The configuration values usually get lost or corrupted when the power of the onboard CMOS battery weakens.



User-configurable fields appear in a different color. If you need information on the selected field, press <F1>. The help menu will then appear to provide you with the information you need. The memory display at the lower right-hand side of the screen is read-only and automatically adjusts accordingly.

# IV. BIOS SOFTWARE

---

## *Details of Standard CMOS Setup:*

### **Date**

To set the date, highlight the “Date” field and then press either <Page Up>, <Page Down>, plus or minus signs (on the numeric keypad) to set the current date. Follow the month, day and year format. Valid values are **Month: (1 to 12)**, **Day: (1 to 31)**, **Year: (up to 2079)**.

### **Time**

To set the time, highlight the “Time” field and then press either <Page Up>, <Page Down>, plus or minus signs (on the numeric keypad) to set the current time. Follow the hour, minute and second format. Valid values are **Hour: (00 to 23)**, **Minute: (00 to 59)**, **Second: (00 to 59)**.

**NOTE:** You can bypass the date and time prompts by creating an AUTOEXEC.BAT file. For information on how to create this file, please refer to the MS-DOS manual.

### **Hard Disk Drives**

This field records the specifications for all non-SCSI hard disk drives installed in your system. The onboard PCI IDE connectors provide Primary and Secondary channels for connecting up to four IDE hard disks or other IDE devices. Each channel can support up to two hard disks; the first of which is the “master” and the second is the “slave”.

Specifications for SCSI hard disks need not to be entered here because they operate using device drivers and are not supported by any BIOS. If you install the optional PCI-SC200 SCSI controller card into the motherboard (see section VI for instructions). If you install other vendor’s SCSI controller card, refer to the documentation that came with the card on how to install the required SCSI drivers.

### **For IDE hard disk drive setup, you can:**

- Use the *Auto* setting for detection during bootup.
- Use the IDE HDD AUTO DETECTION in the main menu to automatically enter the drive specifications.
- Enter the specifications yourself manually by using the “User” option.

The entries for specifying the hard disk type include **CYLS** (number of cylinders), **HEAD** (number of read/write heads), **PRECOMP** (write precompensation), **LANDZ** (landing zone), **SECTOR** (number of sectors) and **MODE**. The **SIZE** field automatically adjusts according to the configuration you specify. The documentation that came with your hard disk should provide you with the information regarding the drive specifications.

## IV. BIOS SOFTWARE

---

The **MODE** entry is for IDE hard disks only, and can be ignored for MFM and ESDI drives. This entry provides three options: *Normal*, *Large*, *LBA*, or *Auto* (see below). Set **MODE** to the *Normal* for IDE hard disk drives smaller than 528MB; set it to *LBA* for drives over 528MB that support Logical Block Addressing (LBA) to allow larger IDE hard disks; set it to *Large* for drives over 528MB that do not support LBA. *Large* type of drive can only be used with MS-DOS and is very uncommon. Most IDE drives over 528MB support the *LBA* mode.

### **Autodetection of Hard Disks on Bootup**

For each field, Primary Master, Primary Slave, Secondary Master, and Secondary Slave, you can select *Auto* under the TYPE and MODE fields. This will enable auto detection of your IDE disk drives during bootup. This will allow you to change your hard disks (with the power off) and then power on without having to reconfigure your hard disk type. If you use older hard disks that do not support this feature, then you must configure the hard disk in the standard method as described earlier using the “User” option.

**NOTE:** After the IDE hard disk drive information has been entered into BIOS, new IDE hard disk drives must be partitioned (such as with FDISK) and then formatted before data can be read from and write on. Primary IDE hard disk drives must have its partition set to *active* (also possible with FDISK).

**NOTE:** SETUP Defaults are noted in parenthesis next to each function heading.

### **Drive A / Drive B (None)**

These fields record the types of floppy disk drives installed in your system. The available options for drives A and B are *360KB, 5.25 in.; 1.2MB, 5.25 in.; 720KB, 3.5 in.; 1.44MB, 3.5 in.; 2.88MB, 3.5 in.; None*.

To enter the configuration value for a particular drive, highlight its corresponding field and then select the drive type using the left or right arrow keys.

### **Floppy 3 Mode Support (Disabled)**

This is the Japanese standard floppy drive. The standard stores 1.2MB in a 3.5-inch disk drive. This is normally disabled but you may choose from either *Drive A*, *Drive B*, *Both*, or *Disabled*.

### **Video (EGA/VGA)**

Set this field to the type of video display card installed in your system. The options are *EGA/VGA*, *CGA 40*, *CGA 80*, and *Mono (for Hercules or MDA)*. If you are using a VGA or any higher resolution card, choose *EGA/VGA*.

### **Halt On (All Errors)**

This field determines which types of errors will cause the system to halt. Choose from either *All Errors*; *No Errors*; *All, But Keyboard*; *All, But Diskette*; or *All, But Disk/Key*.

# IV. BIOS SOFTWARE

## BIOS Features Setup

**BIOS Features Setup** consists of configuration entries that allow you to improve your system performance, or let you set up some system features according to your preference. Some entries are required by the motherboard's design to remain in their default settings.



**NOTE:** SETUP Defaults are noted in parenthesis next to each function heading.

### *Details of BIOS Features Setup*

#### **Virus Warning (Disabled)**

This field protects the boot sector and partition table of your hard disk against accidental modifications. Any attempt to write to them will cause the system to halt and display a warning message. If this occurs, you can either allow the operation to continue or use a bootable virus-free floppy disk to reboot and investigate your system. This setting is recommended because of conflicts with new operating systems or some programs. Installation of these programs requires that you disable *Virus Warning* to prevent write errors.

#### **CPU Internal Cache (Enabled)**

Choose *Disable* to turn off the CPU's built-in level 1 cache.

#### **External Cache (Enabled)**

Choose *Disable* to turn off the CPU's external level 2 cache.

#### **Quick Power On Self Test (Enabled)**

This field speeds up the Power-On Self Test (POST) routine by skipping retesting a second, third, and fourth time. Setup default setting for this field is *Enabled*. A complete test of the system is done on each test.

#### **HDD Sequence SCSI/IDE First (IDE)**

When using both SCSI and IDE hard disk drives, IDE is always the boot disk using drive letter C (default setting of *IDE*). This new feature allows a SCSI hard disk drive to be the boot disk when set to *SCSI*. This allows multiple operating systems to be used on both IDE and SCSI drives or the primary operating system to boot using a SCSI hard disk drive.

# IV. BIOS SOFTWARE

---

## **Boot Sequence (C,A)**

This field determines where the system looks first for an operating system. Options are *C,A*; *A,CDROM,C*; *CDROM,C,A*; *D,A*; *E,A*; *F,A*; *C only*; *LS/ZIP, C*; and *A,C*. The default is to check first the hard disk and then the floppy disk drive, that is, *C, A*.

## **Boot Up Floppy Seek (Disabled)**

When enabled, the BIOS will seek drive A one time.

## **Floppy Disk Access Control (R/W)**

This allows protection of files from the computer system to be copied to floppy disk drives by allowing the setting of *Read Only* to only allow reads from the floppy disk drive but not writes. The setup default *R/W* allows both reads and writes.

## **IDE HDD Block Mode Sectors (HDD MAX)**

This field enhances hard disk performance by making multi-sector transfers instead of one sector per transfer. Most IDE drives, except older versions, can utilize this feature. Selections are *HDD MAX*, *Disabled*, *2*, *4*, *8*, *16*, and *32*.

## **Security Option (System)**

This field determines when the system prompts for the password. The default setting is *System*, where the system prompts for the User Password every time you boot up. The other option is *Setup*, where the system always boots up, and prompts for the Supervisor Password only when the Setup utility is called up. You can specify a password by using the *Supervisor Password* or *User Password* option from the main screen as explained later in this section.

## **PS/2 Mouse Function Control (Auto)**

The default of *Auto* allows the system to detect a PS/2 Mouse on bootup. If detected, IRQ12 will be used for the PS/2 Mouse. IRQ12 will be reserved for expansion cards if a PS/2 Mouse is not detected. *Disabled* will reserve IRQ12 for expansion cards and therefore the PS/2 Mouse will not function.

## **PCI/VGA Palette Snoop (Disabled)**

Some display cards that are nonstandard VGA such as graphics accelerators or MPEG Video Cards may not show colors properly. The setting *Enabled* should correct this problem. Otherwise leave this on the setup default setting of *Disabled*.

## **OS/2 Onboard Memory > 64M (Disabled)**

When using OS/2 operating systems with installed DRAM of greater than 64MB, you need to *Enable* this option otherwise leave this on the setup default of *Disabled*.

.....

## **Video ROM BIOS Shadow (Enabled)**

This field allows you to change the video BIOS location from ROM to RAM. Relocating to RAM enhances system performance, as information access is faster than the ROM.

## **C8000-CBFFF to DC000-DFFFF (Disabled)**

These fields are used for shadowing other expansion card ROMs. If you install other expansion cards with ROMs on them, you will need to know which addresses the ROMs use to shadow them specifically. Shadowing a ROM reduces the memory available between 640KB and 1024KB by the amount used for this purpose.



# IV. BIOS SOFTWARE

## Boot Up NumLock Status (On)

This field enables users to activate the Number Lock function upon system boot.

## Typematic Rate Setting (Disabled)

When enabled, you can set the two typematic controls listed next. Setup default setting is *Disabled*.

## Typematic Rate (Chars/Sec) (6)

This field controls the speed at which the system registers repeated keystrokes. Options range from 6 to 30 characters per second. Setup default setting is **6**; other settings are **8, 10, 12, 15, 20, 24, and 30**.

## Typematic Delay (Msec) (250)

This field sets the time interval for displaying the first and second characters. Four delay rate options are available: 250, 500, 750, and 1000.

## Chipset Features Setup

This “Chipset Features Setup” option controls the configuration of the board’s chipset. Control keys for this screen are the same as for the previous screen.



IV. BIOS  
(Chipset Features)

**NOTE:** SETUP Defaults are noted in parenthesis next to each function heading.

### Details of Chipset Features Setup

#### Auto Configuration (60ns DRAM)

The default setting of *60ns DRAM* sets the optimal timings for items 2 through 9 for 60ns DRAM modules. If you are using 70ns DRAM modules, you must change this item to *70ns DRAM*. See section III for DRAM installation information.

#### DRAM Leadoff Time (Leave on default setting of 5T)

## IV. BIOS SOFTWARE

---

### **Linear Mode SRAM Support (Leave on default setting of Disabled)**

For a slightly better performance on IBM/Cyrix CPUs, this function can be Enabled to switch from Toggle mode SRAM to Linear mode SRAM support. **WARNING:** Intel CPUs currently only support the Toggle mode so this function should be *Disabled* when using Intel CPUs.

### **16-bit ISA Wait State (Leave on default setting of 1 Wait)**

Timing for 16-bit ISA cards.

### **16-bit I/O Recovery Time (Leave on default setting of 5 BUSCLK)**

Timing for 16-bit ISA cards.

### **8-bit I/O Recovery Time (Leave on default setting of 8 BUSCLK)**

Timing for 8-bit ISA cards.

### **ISA Bus Clock (Leave on default setting of PCICLK/4)**

Timing for the ISA bus clock.

### **Video BIOS Cacheable (Leave on default setting of Enabled)**

This allows the video BIOS to be cached to allow faster execution.

### **Memory Hole at Address (None)**

This feature reserves memory address space, *15M-16M*, *14M-16M*, or *12M-16M*, to ISA expansion cards that specifically require this setting. This, however, makes the memory from the specified and up unavailable to the system because expansion cards can only access memory up to 16MB.

### **Refresh Cycle Time (187.2 us)**

This function sets the DRAM refresh rate. A slow refresh cycle time increases the bandwidth available for data transfers. **NOTE:** Some DRAMs are known to lose data without frequent refreshing so the default is set at *187.2 us*.

### **Delayed Transaction (Enabled)**

The default setting of *Enabled* frees the PCI Bus during CPU accessing of 8-bit ISA cards, which normally consume about 50–60 PCI clocks without PCI delayed transaction. For PCI bus masters that cannot use the PCI Bus and some ISA cards that are not PCI 2.1 compliant, set this to *Disabled*.

### **Onboard VGA Memory Size (1MB)**

This function allows the user to allocate either 1MB, 2MB or 4MB memory for the onboard video controller. Larger memory allows more colors and a higher resolution to be selected within each operating system.

### **Onboard VGA Memory Clock (Leave on default setting of Fast)**

This function allows the selection of the video speed. Normal uses 50MHz, Fast uses 60MHz, and Fastest uses 66MHz. If your monitor displays unrecognizable information, *you must* decrease the speed to match your monitor's frequency rate.

.....

### **Onboard FDC Controller (Enabled)**

When enabled, this field allows you to connect your floppy disk drives to the onboard floppy drive connector instead of a separate controller card. If you want to use a different controller card, set this field to *Disabled*.

## IV. BIOS SOFTWARE

---

### **Onboard FDC Swap A: B: (No Swap)**

This field allows you to reverse the hardware drive letter assignments of your floppy disk drives. Two options are available: *No Swap* and *Swap AB*. If you want to switch drive letter assignments through the onboard chipset, set this field to *Swap AB*.

### **Onboard Serial Port 1 (3F8H/IRQ4)**

Settings are *3F8H/IRQ4* (default), *2F8H/IRQ3*, *3E8H/IRQ4*, *2E8H/IRQ10*, and *Disabled* for the onboard serial connector.

### **Onboard Serial Port 2 (2F8H/IRQ3)**

Settings are *3F8H/IRQ4*, *2F8H/IRQ3* (default), *3E8H/IRQ4*, *2E8H/IRQ10*, and *Disabled* for the onboard serial connector.

### **Onboard Parallel Port (378H/IRQ7)**

This field sets the address of the onboard parallel port connector. You can select either *3BCH/IRQ 7*, *378H/IRQ 7* (default), *278H/IRQ 5*, or *Disabled*. If you install an I/O card with a parallel port, ensure that there is no conflict in the address assignments. The PC can support up to three parallel ports as long as there are no conflicts for each port.

### **Parallel Port Mode (ECP+EPP)**

This field allows you to set the operation mode of the parallel port. The setting *Normal*, allows normal-speed operation but in one direction only; *EPP* allows bidirectional parallel port operation at maximum speed; *ECP* allows the parallel port to operate in bidirectional mode and at a speed faster than the maximum data transfer rate; *ECP+EPP* (default) allows normal speed operation in a two-way mode.

### **ECP DMA Select (3)**

This selection is available only if you select *ECP* or *ECP+EPP* in the **Parallel Port Mode**. Select either DMA Channel *1, 3* (default), or *Disable*.

### **UART2 Use Infrared (Disabled)**

When enabled, this field activates the onboard infrared feature and sets the second serial UART to support the infrared module connector on the motherboard. If your system already has a second serial port connected to the onboard COM2 connector, it will no longer work if you enable the infrared feature. By default, this field is set to *Disabled*, which leaves the second serial port UART to support the COM2 serial port connector. See section III for the **IrDA-compliant infrared module connector**.

### **Onboard PCI IDE Enable (Both)**

You can select to enable the *Primary* IDE channel, *Secondary* IDE channel, *Both* (default), or *Disable* both channels (for systems with only SCSI drives).

### **IDE Ultra DMA Mode (Auto)**

This sets the IDE UltraDMA to be active when using UltraDMA-capable IDE devices. The BIOS will automatically adjust or disable this setting for slower IDE devices so that *Auto* or high settings will not cause problems for older IDE devices. Choose *Disable* if you do not want this feature for all devices.

### **IDE 0 Master/Slave PIO/DMA Mode, IDE 1 Master/Slave PIO/DMA Mode (Auto)**

Each channel (0 and 1) has both a master and a slave making four IDE devices possible. Because each IDE device may have a different mode timing (0, 1, 2, 3, 4), it is necessary for these to be independent. PIO and DMA settings can be independently set. The default setting of *Auto* will allow autodetection to ensure optimal performance.

# IV. BIOS SOFTWARE

## Power Management Setup

This “Power Management Setup” option allows you to reduce power consumption. This feature turns off the video display and shuts down the hard disk after a period of inactivity.



**NOTE:** SETUP Defaults are noted in parenthesis next to each function heading.

### Details of Power Management Setup

#### Power Management (User Define)

This field acts as the master control for the power management modes. *User Define* allows you to set power saving options according to your preference; *Disable* disables the power saving features; *Min Saving* puts the system into power saving mode after 40 min of system inactivity; *Max Saving* puts the system into power saving mode after 30 sec of system inactivity.

**IMPORTANT:** Advanced Power Management (APM) should be installed to keep the system time updated when the computer enters suspend mode activated by the BIOS Power Management. For DOS environments, you need to add `DEVICE=C:\DOS\POWER.EXE` in you `CONFIG.SYS`. For Windows 3.x and Windows 95, you need to install Windows with the APM feature. A battery and power cord icon labeled “Power” will appear in the “Control Panel.” Choose “Advanced” in the Power Management Field.

#### Video Off Option (Susp,Stby -> Off )

This field determines when to activate the video off feature for monitor power management. The settings are *All Modes -> Off*; *Always On*; *Suspend -> Off*; and *Susp,Stby -> Off*.

# IV. BIOS SOFTWARE

---

## **Video Off Method (DPMS OFF)**

This field defines the video off features. The following options are available: *DPMS OFF*, *DPMS Reduce ON*, *Blank Screen*, *V/H SYNC+Blank*, *DPMS Standby*, and *DPMS Suspend*. The DPMS (Display Power Management System) features allow the BIOS to control the video display card if it supports the DPMS feature. *Blank Screen* only blanks the screen (use this for monitors without power management or “green” features. If set up in your system, your screen saver will not display with *Blank Screen* selected). *V/H SYNC+Blank* blanks the screen and turns off vertical and horizontal scanning.

.....

## **PM Timers**

This section controls the time-out settings. The fields included in this section are **HDD Power Down**, which places the hard disk into its lowest power consumption mode, and the **Doze**, **Standby** and **Suspend** system inactivation modes. The system automatically “wakes up” from any power saving mode when there is system activity, such as when a key is pressed from the keyboard, or when there is activity detected from the enabled IRQ channels.

### **HDD Power Down (Disable)**

This shuts down any IDE hard disk drives in the system after a period of inactivity, configurable to *1-15 Mins* or *Disable*. This feature does not affect SCSI hard disks.

### **Doze Mode, Standby Mode, Suspend Mode (Disable)**

These fields set the period of time after which each of these modes activate: *30 Sec*, *1 Min*, *2 Min*, *4 Min*, *8 Min*, *20 Min*, *30 Min*, *40 Min*, *1 Hour*, and *Disable*.

.....

## **Power Up Control**

This section determines the ways the system can be controlled when modem activity is detected, or when power to the computer is interrupted and reapplied.

### **Ring Power Up Act (Enable)**

Allows either settings of *Enable* or *Disable* for powering up the computer (turns the ATX power supply on) when the modem begins receiving or transmitting data while the computer is off.

### **Automatic Power Up (Disable)**

Allows you to have an unattended or automatic power up of your system. The default does not allow automatic power up. You may, however, configure your system to power up at a certain time of the day by selecting *Everyday*, which will allow you to set the time or at a certain time and day by selecting *By Date*.

.....

### **IRQ3 (device)-IRQ15 (device)**

You can individually *Enable* or *Disable* each IRQ to include in the sleep function. IRQ8 (RTC Alarm) is usually set to *Disable* so that any software alarm clock or event calendar can wake up the system.

# IV. BIOS SOFTWARE

## PNP and PCI Setup

This “PNP and PCI Setup” option configures the PCI bus slots. All PCI bus slots on the system use INTA#, thus all installed PCI cards must be set to this value.



**NOTE:** SETUP Defaults are noted in parenthesis next to each function heading.

### Details of PNP and PCI Setup

#### PNP OS Installed (No)

When Plug and Play operating systems (OS) are installed, interrupts may be reassigned by the OS when *Yes* is selected. When a non-Plug and Play OS is installed or to prevent reassigning of interrupt settings, select *No*.

#### Slot 1/2/3/4 IRQ (Auto)

The first four fields on the screen set how IRQ use is determined for each PCI slot. Slot 1 (Right) is nearest the memory sockets. The default setting for each field is *Auto*, which uses autorouting to determine IRQ use. The other options are the manual settings of *NA*, *5*, *7*, *9*, *10*, *11*, *12*, *14*, or *15* for each slot.

#### PCI Latency Timer (32 PCI Clock)

The default setting of *32 PCI Clock* enables maximum PCI performance for this motherboard.

## IV. BIOS SOFTWARE

---

### **IRQ xx Used By ISA (No/ICU)**

These fields indicate whether or not the displayed IRQ for each field is being used by a legacy (non-PnP) ISA card. Two options are available: *No/ICU* and *Yes*. The first option, the default value, indicates either that the displayed IRQ is not used or an ISA Configuration Utility (ICU) is being used to determine if an ISA card is using that IRQ. If you install a legacy (non-PnP) ISA card that requires a unique IRQ, and you are not using an ICU, you must set the field for that IRQ to *Yes*. For example: If you install a legacy ISA card that requires IRQ 10, then set **IRQ10 Used By ISA** to *Yes*.

.....

### **DMA x Used By ISA (No/ICU)**

These fields indicate whether or not the displayed DMA channel for each field is being used by a legacy ISA card. Available options include: *No/ICU* and *Yes*. The first option, the default setting, indicates either that the displayed DMA channel is not used or an ICU is being used to determine if an ISA card is using that channel. If you install a legacy ISA card that requires a unique DMA channel, and you are not using an ICU, you must set the field for that channel to *Yes*.

### **ISA MEM Block BASE (No/ICU)**

This field allows you to set the base address and block size of a legacy ISA card that uses any memory segment within the C800, CC00, D000, D400, D800, and DC00 address range. If you have such a card, and you are not using an ICU to specify its address range, select a base address from the six available options; the **ISA MEM Block SIZE** field will then appear for selecting the block size. If you have more than one legacy ISA card in your system that requires to use this address range, you can increase the block size to either 8K, 16K, 32K, or 64K. If you are using an ICU to accomplish this task, leave **ISA MEM Block BASE** to its default setting of *No/ICU*.

### **SYMBIOS SCSI BIOS (Auto)**

The default uses *Auto* settings for the onboard SCSI BIOS. If you do not want to use the onboard SCSI BIOS, choose *Disabled*.

### **USB Function (Disabled)**

The motherboard supports Universal Serial Bus (USB) devices but current operating systems do not. The default is set to *Disabled*. If you have the necessary support disks and USB devices, set this function to *Enabled* to use the onboard USB connector.

### **USB IRQ (Auto)**

When USB devices are connected to the onboard USB connector, the resource settings or IRQs for these devices are, by default, automatically assigned by the BIOS. You may manually select the settings: 5, 7, 9, 10, 11, 12, 14, and 15. If you are not using any USB devices, you may set this field to *N/A*.

# IV. BIOS SOFTWARE

## Load BIOS Defaults

This “Load BIOS Defaults” option allows you to load the troubleshooting default values permanently stored in the BIOS ROM. These default settings are non-optimal and disable all high performance features. To load these default settings, highlight “Load BIOS Defaults” on the main screen and then press <Enter>. The system displays a confirmation message on the screen. Press <Y> and then <Enter> to confirm. Press <N> and then <Enter> to abort. This feature does not affect the fields on the Standard CMOS Setup screen.

## Load Setup Defaults

This “Load Setup Defaults” option allows you to load the default values to the system configuration fields. These default values are the optimized configuration settings for the system. To load these default values, highlight “Load Setup Defaults” on the main screen and then press <Enter>. The system displays a confirmation message on the screen. Press <Y> and then <Enter> to confirm. Press <N> and then <Enter> to abort. This feature does not affect the fields on the Standard CMOS Setup screen.



IV. BIOS  
(Load Defaults)



# IV. BIOS SOFTWARE

## Supervisor Password and User Password

These two options set the system passwords. “Supervisor Password” sets a password that will be used to protect the system and the Setup utility; “User Password” sets a password that will be used exclusively on the system. By default, the system comes without any passwords. To specify a password, highlight the type you want and then press <Enter>. A password prompt appears on the screen. Taking note that the password is case sensitive, and can be up to 8 alphanumeric characters long, type in your password and then press <Enter>. The system confirms your password by asking you to type it again. After setting a password, the screen automatically reverts to the main screen.



To implement the password protection, specify in the “Security Option” field of the BIOS Features Setup screen when the system will prompt for the password. If you want to disable either password, press <Enter> instead of entering a new password when the “Enter Password” prompt appears. A message confirms the password has been disabled.

**NOTE:** If you forget the password, see CMOS RAM in section III for procedures on clearing the CMOS.

# IV. BIOS SOFTWARE

## IDE HDD Auto Detection

This “IDE HDD Auto Detection” option detects the parameters of an IDE hard disk drive, and automatically enters them into the “Standard CMOS Setup” screen.

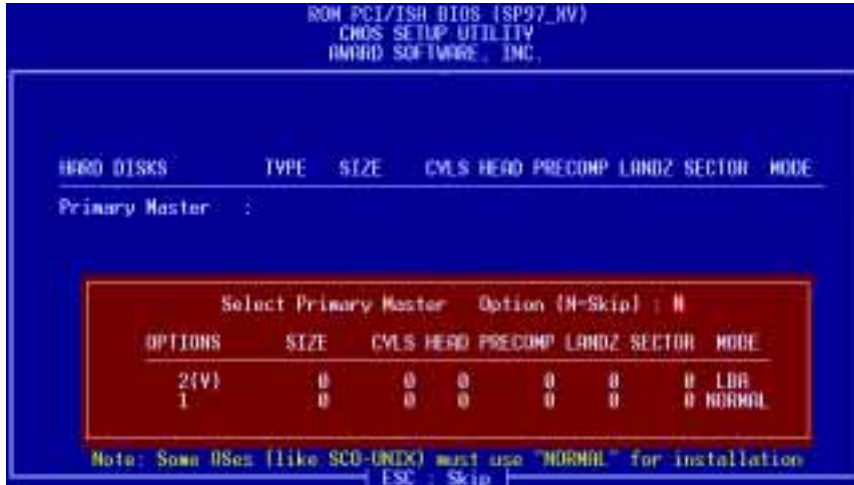

Up to four IDE drives can be detected, with parameters for each listed inside the box. To accept the optimal entries, press <Y>, otherwise select from the numbers displayed under the OPTIONS field (2, 1, 3 in this case); to skip to the next drive, press <N>. If you accept the values, the parameters will appear listed beside the drive letter on the screen. The process then proceeds to the next drive letter. Pressing <N> to skip rather than to accept a set of parameters causes the program to enter zeros after that drive letter.

If you are using another IDE controller that does not feature Enhanced IDE support for four devices, you can only install two IDE hard disk drives. Your IDE controller must support the Enhanced IDE features to use Drive E and Drive F. The onboard PCI IDE controller supports Enhanced IDE, with two connectors for connecting up to four IDE devices. If you want to use another controller that supports four drives, you must disable the onboard IDE controller in the Chipset Features Setup screen.

When autodetection is completed, the program automatically enters all entries you accepted on the field for that drive in the “Standard CMOS Setup” screen. Skipped entries are ignored and are not entered in the screen.

If you are autodetecting a hard disk that supports the LBA mode, three lines will appear in the parameter box. Choose the line that lists LBA for an LBA drive. Do not select Large or Normal.

The autodetection feature can only detect one set of parameters for a particular IDE hard disk. Some IDE drives can use more than one set. This is not a problem if the drive is new and there is nothing on it.

## IV. BIOS SOFTWARE

**IMPORTANT:** If your hard disk was already formatted on an older previous system, incorrect parameters may be detected. You will need to enter the correct parameters manually or use low-level format if you do not need the data stored on the hard disk.

If the parameters listed differ from the ones used when the drive was formatted, the drive will not be readable. If the autodetected parameters do not match the ones that should be used for your drive, do not accept them. Press <N> to reject the presented settings and enter the correct ones manually from the “Standard CMOS Setup” screen.

### Save and Exit Setup

Select this option to save into the CMOS memory all modifications you specify during the current session. To save the configuration changes, highlight “Save & Exit Setup” on the main screen, type “Y”, and then press <Enter>.



### Exit Without Saving

Select this option to exit the Setup utility without saving the modifications you specify during the current session. To exit without saving, highlight “Exit Without Saving” on the main screen, type “Y”, and then press <Enter>.

# V. SUPPORT SOFTWARE

---

## Desktop Management Interface (DMI)

### *Introducing the ASUS DMI Configuration Utility*

This motherboard supports DMI within the BIOS level and provides a DMI Configuration Utility to maintain the Management Information Format Database (MIFD). DMI is able to autodetect and record information pertinent to a computer's system such as the CPU type, CPU speed, and internal/external frequencies, and memory size. The onboard BIOS will detect as many system information as possible and store those collected information in a 4KB block in the motherboard's Flash EPROM and allow the DMI to retrieve data from this database. Unlike other BIOS software, the BIOS on this motherboard uses the same technology implemented for Plug and Play to allow dynamic real-time updating of DMI information versus creating a new BIOS image file and requiring the user to update the whole BIOS. This DMI Configuration Utility also allows the system integrator or end user to add additional information into the MIFD such as serial numbers, housing configurations, and vendor information. Those information not detected by the motherboard BIOS and has to be manually entered through the DMI Configuration Utility and updated into the MIFD. This DMI Configuration Utility provides the same reliability as PnP updating and will prevent the refreshing failures associated with updating the entire BIOS.

### *System Requirements*

The DMI Configuration Utility (DMICFG.EXE) must be used in real mode in order for the program to run, the base memory must be at least 180K. Memory managers like HIMEM.SYS (required by windows) must not be installed. You can boot up from a system diskette without AUTOEXEC.BAT and CONFIG.SYS files, "REM" HIMEM.SYS in the CONFIG.SYS, or press <F5> during bootup to bypass your AUTOEXEC.BAT and CONFIG.SYS files.

# V. SUPPORT SOFTWARE

## Using the ASUS DMI Configuration Utility

### Edit DMI (or delete)



Use the ←→ (left-right) cursors to move the top menu items and the ↑↓ (up-down) cursor to move between the left hand menu items. The bottom of the screen will show the available keys for each screen. Press enter at the menu item to enter the right hand screen for editing. “Edit component” appears on top. The reversed color field is the current cursor position and the blue text are available for editing. The orange text shows autodetected information and are not available for editing. The blue text “Press [ENTER] for detail” contains a second pop-up menu is available, use the + - (plus-minus) keys to change the settings. Enter to exit *and save*, ESC to exit *and not save*.

If the user has made changes, ESC will prompt you to answer Y or N. Enter Y to go back to the left-hand screen *and save*, enter N to go back to left-hand screen and *not save*. If editing has not been made, ESC will send you back to the left hand menu without any messages.

### Notes

A heading, \*\*\* BIOS Auto Detect \*\*\*, appears on the right for each menu item on the left side that has been auto detected by the system BIOS.

A heading, \*\*\* User Modified \*\*\*, will appear on the right for menu items that has been modified by the user.



# V. SUPPORT SOFTWARE

## Save MIFD



You can save the MIFD (normally only saved to flash ROM) to a file by entering the drive and path here. If you want to cancel save, you may press ESC and a message “Bad File Name” appears here to show it was not saved.

## Load MIFD



You can load the disk file to memory by entering a drive and path and file name here.

## Load BIOS Defaults



You can load the BIOS defaults from a MIFD file and can clear all user modified and added data. You must reboot your computer in order for the defaults to be saved back into the Flash BIOS.

# VI. ASUS PCI SCSI Cards

## Symbios SCSI BIOS and Drivers

**NOTE:** The ASUS PCI-SC860 is not supported on the SP97-XV because the EEPROM space is required for the onboard VGA BIOS.

Aside from the system BIOS, the Flash memory chip on the motherboard also contains the Symbios SCSI BIOS. This Symbios SCSI BIOS works in conjunction with the optional ASUS PCI-SC200 controller card to provide Fast SCSI-2 interface when using compatible SCSI devices or the ASUS PCI-SC860 SCSI controller cards to provide Ultra-Fast SCSI-2 interface when using Ultra-Fast SCSI-2 devices.

All SCSI devices you install on your system require driver software to function. The Symbios SCSI BIOS directly supports SCSI hard disks under the DOS, Windows and OS/2 environments. It also uses device drivers from the DOS floppy disk included in the ASUS PCI-SC200 and ASUS PCI-SC860 controller card packages to support hard disks and other SCSI devices working under DOS, Microsoft Windows, Microsoft Windows NT, Novell NetWare and IBM OS/2. These drivers provide higher performance than the direct BIOS support. To use these drivers, you must install them into your system and add them to your system configuration files. Driver support for SCSI devices used with SCO UNIX is also provided. These drivers are included in the second SCO UNIX floppy disk. Windows 95 support is also available using the device drivers included within the Windows software. The ASUS PCI-SC200 and ASUS PCI-SC860 are Plug and Play adapters that are auto detected by BIOS and current operating systems that support Plug and Play features.

For information about these drivers and their usage, please view the Readme files included in the driver packages.

## ASUS PCI-SC200 & PCI-SC860 SCSI Cards

The ASUS PCI-SC200 or the ASUS PCI-SC860 may be bundled with your motherboard or purchased separately. Both cards provide the option of connecting internal or external SCSI devices for a total of 7 devices on each SCSI card.



# VI. ASUS PCI SCSI Cards

## Setting Up the ASUS PCI-SC200 & PCI-SC860

There are two jumper settings you may need to make on the ASUS PCI-SC200 to set it up. One setting assigns the PCI INT interrupt, the other sets the card's termination. The ASUS PCI-SC860 has no jumper settings but you should read the "Terminator Requirements."

## Setting the INT Assignment for the ASUS PCI-SC200

You must use PCI INT A setting in order to properly assign the ASUS PCI-SC200's interrupt. On the ASUS PCI-SC200, you assign the INT by setting jumper JP1 or JP2. The default setting for the card already is INT A, so you do not need to change the setting to use the ASUS PCI-SC200 with this motherboard.

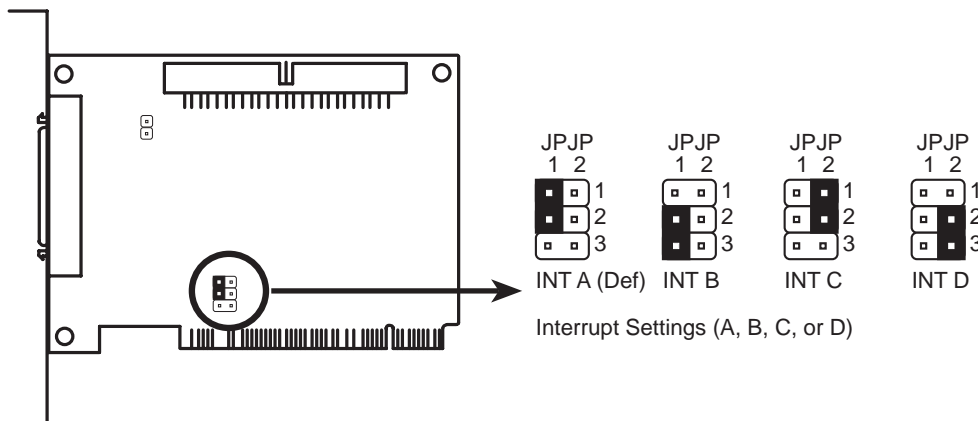

## Terminator Requirements for SCSI Devices

SCSI devices are connected together in a "chain" by cables. Internal devices connect to the ASUS PCI-SC200 or ASUS PCI-SC860 with a fifty-pin flat ribbon cable. External devices connect to the external port with a SCSI-2 cable. If there are more than one internal or external devices, additional devices are connected with cables to form a "daisy chain." Terminating the devices on the ends of the SCSI Bus "chain" is necessary for SCSI devices to work properly. Termination of the devices between the ends must be *Disabled*.



# VI. ASUS PCI SCSI Cards

## Terminator Settings for the ASUS PCI-SC860

Many SCSI devices including the ASUS PCI-SC860 use a set of onboard active resistors to terminate the devices at the ends automatically. Automatic termination requires that the SCSI devices be connected in a straight linear connection or “chain.” Connect SCSI devices to one or two of the SCSI connectors in a linear “chain” for auto termination of the ASUS PCI-SC860 to be effective. Other formations will cause your SCSI devices to not mount properly. You must use the **end** of the ribbon cable when using the internal connector(s) to keep a linear path.

**Additional Note: The Symbios Logic SCSI Configuration Utility is a powerful tool. If, while using it, you somehow disable all your controllers or cannot enter the configuration utility, pressing “Ctrl-A” after memory count during reboot allows you to recover and reconfigure.**

## Terminator Settings for the ASUS PCI-SC200

The ASUS PCI-SC200, on the other hand, has “active” termination that you must set using jumper JP5. There are two settings, "terminated" and "not terminated," as shown below.

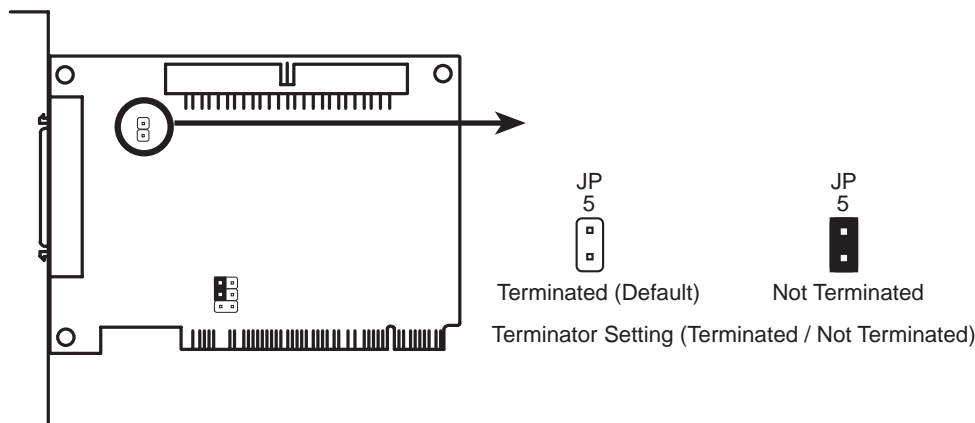

Decide whether or not you need to terminate the ASUS PCI-SC200 based on its position in the SCSI chain. Only the devices at each end of the chain need to be terminated. If you have **only** internal or **only** external devices connected to the ASUS PCI-SC200, then you **must** terminate the ASUS PCI-SC200. If you have **both** internal and external devices connected, you **must not** terminate the card. See the following examples which illustrate this concept.

## VI. ASUS PCI SCSI Cards

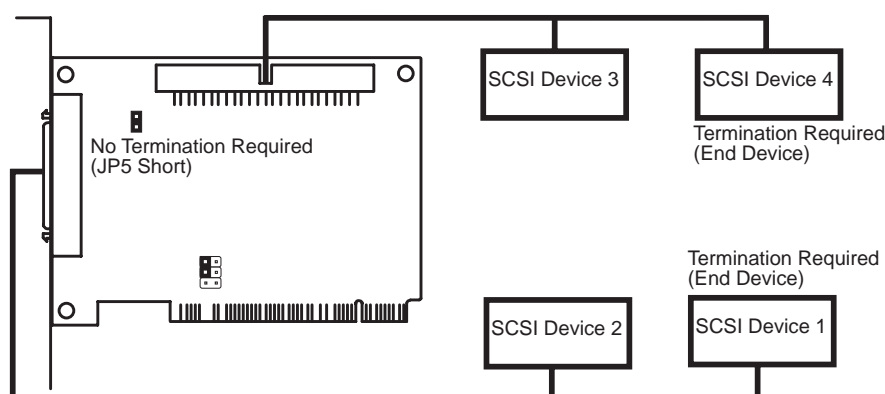
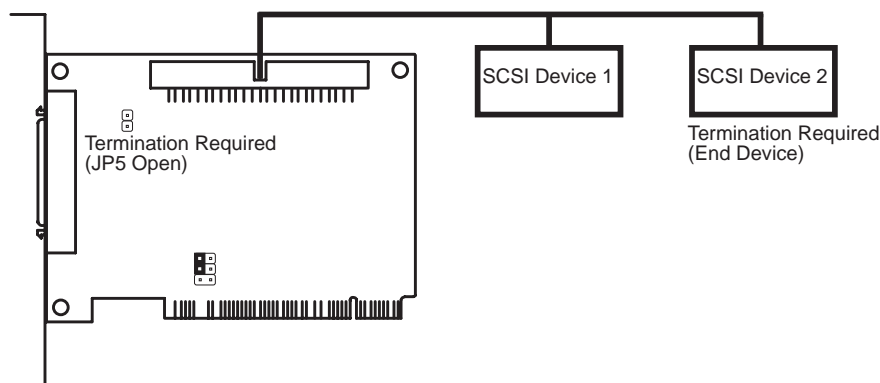

### SCSI ID Numbers for SCSI Devices

All SCSI devices, including the ASUS PCI-SC200 and ASUS PCI-SC860 interface card must have a SCSI identification number that is not in use by any other SCSI device. There are eight possible ID numbers, 0 through 7. The ASUS PCI-SC200 and ASUS PCI-SC860 cards have fixed SCSI IDs of 7. The SCSI ID serves two purposes:

- It uniquely defines each SCSI device on the bus.
- It determines which device controls the bus when two or more devices try to use it at the same time.

SCSI IDs on one channel do not interfere with the IDs on another channel. This applies to two SCSI host adapters that implement different buses as well as dual channels on a single host adapter. You can connect up to seven SCSI devices to the interface card. You must set a SCSI ID number (ID 0 to ID 6) for each device. SCSI devices vary in how they set the ID number. Some use jumpers, others have some kind of selector switch. Refer to the manual for any device you install for details on how to set its ID number.

### SCSI ID Priority

The ASUS PCI-SC200 and ASUS PCI-SC860 are 8bit single-channel SCSI cards. SCSI ID 7 has the highest priority, and SCSI ID 0 has the lowest priority.

**ASUS<sup>®</sup> SP97-XV**  
Pentium<sup>®</sup> Motherboard

**VIDEO SOFTWARE  
USER'S MANUAL**

# CONTENTS

---

VIDEO SOFTWARE USER'S MANUAL .....	65
VIII. DOS UTILITY .....	67
DOS Utility .....	67
1. SVGAUTL.EXE .....	67
1.1 General Description .....	67
1.2 How to Use? .....	67
1.3 What the Parameters Stand for? .....	68
A1. Video Modes .....	69
IX. SOFTWARE DRIVERS .....	74
Software Drivers .....	74
1. Windows 3.1 .....	75
1.0 Version Notes .....	75
1.1 Driver Files .....	75
1.2 Installation .....	76
1.3 Video Operations .....	78
MMPLAY.EXE Button Description .....	79
2. Windows 95 .....	81
2.0 Version Note .....	81
2.1 Driver Files .....	81
2.2 Installation .....	81
2.3 Using "Display Modes" .....	82
2.4 Utilities .....	83
3. Windows NT 3.5 & 3.51 .....	84
4. Windows NT 4.0 .....	85
5. Autodesk ADI 4.2 -Protected Mode .....	86
5.0 General Description .....	86
5.1 AutoCAD R11 Setup .....	87
5.2 AutoCAD R1.2 Setup .....	88
5.3 AutoShade R2.0 Setup .....	89
5.4 3D Studio Version 3.0 Setup .....	90
6. OS/2 V2.1 .....	92
6.0 Driver Notes .....	92
6.1 Driver Files .....	92
6.2 Installation .....	92
7. OS/2 V3.0 (Warp) .....	93
7.0 Driver & OS/2 Version Notes .....	93
7.1 Driver Files .....	93
7.2 Installation .....	93
8. Double Bytes OS/2 Warp .....	94
8.0 Driver & OS/2 Version Notes .....	94
8.1 Driver Files .....	94
8.2 Installation .....	95

# VIII. DOS UTILITY

---

## DOS Utility

### 1. SVGAUTL.EXE

#### 1.1 General Description

SVGAUTL.EXE is one of the utilities of SiS 5597/5598. It supports three functions:

- (1) Video Mode Setting
- (2) Frame Rate Setting
- (3) Power Saving Setting

Since SiS 5597/5598 supports many enhanced Text Mode and Graphic Mode, you can use SVGAUTL.EXE to select the desired video mode.

For 640x480, 800x600, 1024x768, and 1280x1024 resolutions, SiS 5597/5598 supports multiple frame rates.

If your monitor could synchronize with these frame rates, you can use SVGAUTL.EXE to get advantage.

SiS 5597/5598 also supports VESA DPMS Power Saving Modes.

SVGAUTL.EXE can help you to set the capability.

#### 1.2 How to Use?

##### To use SVGAUTL.EXE:

1. Type SVGAUTL in the directory where it resides.  
For example, **C:\>SVGAUTL <Enter>** (assuming SVGAUTL.EXE is in C:\)
2. The Main Menu would appear and direct you to configure SiS 5597/5598.
3. When you complete configuration, you may save your preferences to "AUTOEXEC.BAT file and use it as your power-on (or hardware reset) default environment.

# VIII. DOS UTILITY

---

## 1.3 What the Parameters Stand for?

The meaning of parameters used by SVGAUTL.EXE are explained below:

Syntax:

```
>SVGAUTL [/D:mode_no] [/F0:n0] [/F1:n1] [/F2:n2] [/F3:n3] [/PA:ta] [/PB:tb]
```

where

**/D:** Set the Video Mode to be mode\_no which is a hex number.

For example: Set 1024x768 256 color graphic mode.

```
>SVGAUTL /D:38 <Enter>
```

**/F0:** For 640x480, set frame rate to be n0 Hz.

Three available frame rates are 60, 72, and 75 Hz.

For example : Set 640x480 graphic mode with 60Hz frame rate

```
>SVGAUTL /F0:60 <Enter>
```

**/F1:** For 800x600, set frame rate to be n1 Hz.

Four available frame rates are 56, 60, 72, and 75 Hz.

For example : Set 800x600 graphic mode with 72Hz frame rate.

```
>SVGAUTL /F1:72 <Enter>
```

**/F2:** For 1024x768, set frame rate to be n2 Hz.

Four available frame rates are 87 (Interlace), 60, 70, and 75 Hz.

For example : Set 1024x768 graphic mode with 60Hz frame rate.

```
>SVGAUTL /F2:60 <Enter>
```

**/F3:** For 1280x1024, set frame rate to be n3 Hz.

Two available frame rates are 87 (Interlace) and 60 Hz.

For example : Set 1280x1024 graphic mode with 60Hz frame rate.

```
>SVGAUTL /F3:60 <Enter>
```

**/PA:** Set Standby Timer to be ta minutes. (0 < ta < 15 min.)

For example : Set Standby Timer be 5 minutes.

```
>SVGAUTL /PA:5 <Enter>
```

**/PB:** Set Suspend Timer to be tb minutes. (0 < tb < 15 min.)

For example : Set Suspend Timer be 5 minutes.

```
>SVGAUTL /PB:5 <Enter>
```

**Note:** 1. Suspend Time would be “ta + tb”. (i.e. standby time + suspend time)  
2. The timers will not be very accurate and would just be around the time.

# VIII. DOS UTILITY

## A1. Video Modes

### A1.1 Standard VGA Modes

MODE	TYPE	DISPLAY SIZE	COLORS SHADES	ALPHA FORMAT	BUFFER START	BOX SIZE	MAX PAGES
0	A/N	320x200	16	40x25	B800	8x8	8
0*	A/N	320x350	16	40x25	B800	8x14	8
0+	A/N	360x400	16	40x25	B800	9x16	8
1	A/N	320x200	16	40x25	B800	8x8	8
1*	A/N	320x350	16	40x25	B800	8x14	8
1+	A/N	360x400	16	40x25	B800	9x16	8
2	A/N	640x200	16	80x25	B800	8x8	8
2*	A/N	640x350	16	80x25	B800	8x14	8
2+	A/N	720x400	16	80x25	B800	9x16	8
3	A/N	640x200	16	80x25	B800	8x8	8
3*	A/N	640x350	16	80x25	B800	8x14	8
3+	A/N	720x400	16	80x25	B800	9x16	8
4	APA	320x200	4	40x25	B800	8x8	1
5	APA	320x200	4	40x25	B800	8x8	1
6	APA	640x200	2	80x25	B800	8x8	1
7	A/N	720x350	4	80x25	B000	9x14	8
7+	A/N	720x400	4	80x25	B000	9x16	8
0D	APA	320x200	16	40x25	A000	8x8	8
0E	APA	640x200	16	80x25	A000	8x8	4
0F	APA	640x350	2	80x25	B000	8x14	2
10	APA	640x350	16	80x25	A000	8x14	2
11	APA	640x480	2	80x30	A000	8x16	1
12	APA	640x480	16	80x30	A000	8x16	1
13	APA	320x200	256	40x25	A000	8x8	1

NOTE: 1. A/N: Alpha/Numeric

2. APA: All Point Addressable (Graphics)

# VIII. DOS UTILITY

MODE	DISPLAY SIZE	COLORS SHADES	FRAME RATE.	H-SYNC.	VIDEO FREQ.
0	320x200	16	70	31.5 K	25.1 M
0*	320x350	16	70	31.5 K	25.1 M
0+	360x400	16	70	31.5 K	28.3 M
1	320x200	16	70	31.5 K	25.1 M
1*	320x350	16	70	31.5 K	25.1 M
1+	360x400	16	70	31.5 K	28.3 M
2	640x200	16	70	31.5 K	25.1 M
2*	640x350	16	70	31.5 K	25.1 M
2+	720x400	16	70	31.5 K	28.3 M
3	640x200	16	70	31.5 K	25.1 M
3*	640x350	16	70	31.5 K	25.1 M
3+	720x400	16	70	31.5 K	28.3 M
4	320x200	4	70	31.5 K	25.1 M
5	320x200	4	70	31.5 K	25.1 M
6	640x200	2	70	31.5 K	25.1 M
7*	720x350	4	70	31.5 K	28.3 M
7+	720x400	4	70	31.5 K	28.3 M
0D	320x200	16	70	31.5 K	25.1 M
0E	640x200	16	70	31.5 K	25.1 M
0F	640x350	2	70	31.5 K	25.1 M
10	640x350	16	70	31.5 K	25.1 M
11	640x480	2	60	31.5 K	25.1 M
12	640x480	16	60	31.5 K	25.1 M
13	320x200	256	70	31.5 K	25.1 M

NOTE: i - interlaced mode  
n - noninterlaced mode



# VIII. DOS UTILITY

## A1.2 Enhanced Video Modes

MODE	TYPE	DISPLAY SIZE	COLORS SHADES	ALPHA FORMAT	BUFFER START	BOX SIZE	MAX. PAGES
22	A/N	1056x352	16	132x44	B800	8x8	2
23	A/N	1056x350	16	132x25	B800	8x14	4
24	A/N	1056x364	16	132x28	B800	8x13	4
25	APA	640x480	16	80x60	A000	8x8	1
26	A/N	720x480	16	80x60	B800	9x8	3
29	APA	800x600	16	100x37	A000	8x16	1
2A	A/N	800x600	16	100x40	B800	8x15	4
2D	APA	640x350	256	80x25	A000	8x14	1
2E	APA	640x480	256	80x30	A000	8x16	1
2F	APA	640x400	256	80x25	A000	8x16	1
30	APA	800x600	256	100x37	A000	8x16	1
37	APA	1024x768	16	128x48	A000	8x16	1
38	APA	1024x768	256	128x48	A000	8x16	1
39	APA	1280x1024	16	160x64	A000	8x16	1
3A	APA	1280x1024	256	160x64	A000	8x16	1
40	APA	320x200	32K	40x25	A000	8x8	1
41	APA	320x200	64K	40x25	A000	8x8	1
42	APA	320x200	16.8M	40x25	A000	8x8	1
43	APA	640x480	32K	80x30	A000	8x16	1
44	APA	640x480	64K	80x30	A000	8x16	1
45	APA	640x480	16.8M	80x30	A000	8x16	1
46	APA	800x600	32K	100x37	A000	8x16	1
47	APA	800x600	64K	100x37	A000	8x16	1
48	APA	800x600	16.8M	100x37	A000	8x16	1
49	APA	1024x768	32K	128x48	A000	8x16	1
4A	APA	1024x768	64K	128x48	A000	8x16	1
4B	APA	1024x768	16.8M	128x48	A000	8x16	1
4C	APA	1280x1024	32K	160x64	A000	8x16	1
4D	APA	1280x1024	64K	160x64	A000	8x16	1

NOTE: 1. A/N: Alpha/Numeric  
2. APA: All Point Addressable (Graphics)

# VIII. DOS UTILITY

MODE	DISPLAY SIZE	COLORS SHADES	FRAME RATE.	H-SYNC.	VIDEO FREQ.
22	1056x352	16	70	30.5 K	40.0 M
23	1056x350	16	70	30.5 K	40.0 M
24	1056x364	16	70	30.5 K	40.0 M
25	640x480	16	60	31.5 K	25.1 M
26	720x480	16	60	31.5 K	25.1 M
29	800x600	16	56	35.1 K	30.0 M
29*	800x600	16	60	37.9 K	40.0 M
29+	800x600	16	72	48.0 K	50.0 M
29#	800x600	16	75	46.8 K	50.0 M
29##	800x600	16	85	53.7 K	56.3 M
2A	800x600	16	56	35.1 K	36.0 M
2D	640x350	256	70	31.5 K	25.1 M
2E	640x480	256	60	31.5 K	25.1 M
2E*	640x480	256	72	37.9 K	31.5 M
2E+	640x480	256	75	37.5 K	31.5 M
2E++	640x480	256	85	43.4 K	36.0 M
2F	640x400	256	70	31.5 K	25.1 M
30	800x600	256	56	35.1 K	36.0 M
30*	800x600	256	60	37.9 K	40.0 M
30+	800x600	256	72	48.0 K	50.0 M
30#	800x600	256	75	46.8 K	50.0 M
30##	800x600	256	85	53.7 K	56.3 M
37i	1024x768	16	87	35.5 K	44.9 M
37n	1024x768	16	60	48.4 K	65.0 M
37n+	1024x768	16	70	56.5 K	75.0 M
37n#	1024x768	16	75	60.2 K	80.0 M
37n##	1024x768	16	85	68.7 K	94.5 M
38i	1024x768	256	87	35.5 K	44.9 M
38n	1024x768	256	60	48.4 K	65.0 M
38n+	1024x768	256	70	56.5 K	75.0 M
38n#	1024x768	256	75	60.2 K	80.0 M
38n##	1024x768	256	85	68.7 K	94.5 M
39i	1280x1024	16	87	48.8 K	80.0 M
39n	1280x1024	16	60	65.0 K	110.0 M
39n+	1280x1024	16	75	80.0 K	135.0 M
3Ai	1280x1024	256	87	48.8 K	80.0 M
3An	1280x1024	256	60	65.0 K	110.0 M
3An+	1280x1024	256	75	80.0 K	135.0 M
40	320x200	32K	70	31.5 K	25.1 M
41	320x200	64K	70	31.5 K	25.1 M
42	320x200	16.8M	70	31.5 K	25.1 M
43	640x480	32K	60	31.5 K	25.1 M
43*	640x480	32K	72	37.9 K	31.5 M
43+	640x480	32K	75	37.5 K	31.5 M
43++	640x480	32K	85	43.4 K	36.0 M
44	640x480	64K	60	31.5 K	25.1 M
44*	640x480	64K	72	37.9 K	31.5 M
44+	640x480	64K	75	37.5 K	31.5 M

## VIII. DOS UTILITY

MODE	DISPLAY SIZE	COLORS SHADES	FRAME RATE.	H-SYNC.	VIDEO FREQ.
44++	640x480	64K	85	43.4 K	36.0 M
45	640x480	16.8M	60	31.5 K	25.1 M
45*	640x480	16.8M	72	37.9 K	31.5 M
45+	640x480	16.8M	75	37.5 K	31.5 M
45++	640x480	16.8M	85	43.4 K	36.0 M
46	800x600	32K	56	35.1 K	36.0 M
46*	800x600	32K	60	37.9 K	40.0 M
46+	800x600	32K	72	48.0 K	50.0 M
46#	800x600	32K	75	46.8 K	50.0 M
46##	800x600	32K	85	53.7 K	56.3 M
47	800x600	64K	56	35.1 K	36.0 M
47*	800x600	64K	60	37.9 K	40.0 M
47+	800x600	64K	72	48.0 K	50.0 M
47#	800x600	64K	75	46.8 K	50.0 M
47##	800x600	64K	85	53.7 K	56.3 M
48	800x600	16.8M	56	35.1 K	36.0 M
48*	800x600	16.8M	60	37.9 K	40.0 M
48+	800x600	16.8M	72	48.0 K	50.0 M
48#	800x600	16.8M	75	46.8 K	50.0 M
48##	800x600	16.8M	85	53.7 K	56.3 M
49i	1024x768	32K	87	35.5 K	44.9 M
49n	1024x768	32K	60	48.4 K	65.0 M
49n+	1024x768	32K	70	56.5 K	75.0 M
49n#	1024x768	32K	75	60.2 K	80.0 M
49n##	1024x768	32K	85	68.7 K	94.5 M
4Ai	1024x768	64K	87	35.5 K	44.9 M
4An	1024x768	64K	60	48.4 K	65.0 M
4An+	1024x768	64K	70	56.5 K	75.0 M
4An#	1024x768	64K	75	60.2 K	80.0 M
4An##	1024x768	64K	85	68.7 K	94.5 M
4Bi	1024x768	16.8M	87	35.5 K	44.9 M
4Bn	1024x768	16.8M	60	48.4 K	65.0 M
4Bn+	1024x768	16.8M	70	56.5 K	75.0 M
4Bn#	1024x768	16.8M	75	60.2 K	80.0 M
4Bn##	1024x768	16.8M	85	68.7 K	94.5 M
4Ci	1280x1024	32K	89	48.8 K	80.0 M
4Di	1280x1024	64K	89	48.8 K	80.0 M

NOTE: i - interlaced mode  
n - noninterlaced mode

\* For the limitation of memory bandwidth in 1MB DRAM configuration, the following video modes is not supported in 1MB configuration: modes 45\*, 45+, 46+, 46#, 47+, and 47#.

# IX. SOFTWARE DRIVERS

---

## Software Drivers

To make use of the advance features of SiS 5597/5598, extended graphic and text modes are supported by software application drivers developed by SiS. The following applications are currently supported:

- 3D Studio Ver. 3.0
- AutoCAD/386 Release 11, 12
- Auto Shade/386 Ver. 2.0
- MicroSoft Windows 3.1
- MicroSoft Windows NT Ver. 3.1, 3.5, 3.51, 4.0
- MicroSoft Windows 95
- OS/2 Presentation Manager 2.1 & 3.0

# IX. SOFTWARE DRIVERS

---

## 1. Windows 3.1

### *1.0 Version Notes*

The following description apply to “SiS 5597/5598 Driver Release V1.03” and maybe later release version but not guaranteed.

### *1.1 Driver Files*

1. The enclosed SiS 5597/5598 Windows 3.1 driver contains SETUP.EXE and other installation-related files.

# IX. SOFTWARE DRIVERS

---

## 1.2 Installation

### 1.2.1 Unpack & Copy

To unpack and copy drivers to where they should reside, please follow the following procedures:

1. Boot up Windows using standard VGA mode.
2. In Windows Program Manager Screen, choose “File” item.
3. In “File Item List”, choose “Run” item.
4. In “Run” Screen, select your driver source. e.g. D:\MM\WIN31\SETUP.EXE
5. Follows the directions appeared on the screen to complete the unpack & copy procedures.
6. After unpack & copy complete, a SiS Multimedia Vx.xx” program group would be created and shown on screen.
7. In the “SiS Multimedia Vx.xx” program group, there would be five icons:
  - (1) SiS Multimedia Manager: To create a small “SiS Multimedia” icon on the corner of the screen.
  - (2) SVGA Setup: SiS VGA graphics configuration system
  - (3) SiS MMPlayer: To create a SiS MMPlayer” VCP-like icon on the screen.
  - (4) Center Screen: An utility to adjust the position of display on the screen.
  - (5) Uninstall utility.

### 1.2.2 Graphics Setup

1. In “SiS Multimedia Vx.xx” program group, choose “SVGA Setup” icon to enter “SiS VGA Configuration System” screen.
2. In “SiS VGA Configuration System” Screen, choose which options you would like to use.
3. After completing your selections, choose “OK” to make all your selections effective.
4. Choose “Restart Windows” to re-boot Windows using new settings. Or, choose “Continue” to continue your current Windows processes. (But when you re-boot Windows, the new settings would take effect.)

# IX. SOFTWARE DRIVERS

---

## 1.2.3 Power Saving Setup in Windows

1. In “SiS VGA Configuration System” screen, choose “power saver” item to enter “Power Saver” screen.
2. In “Power Saver” Screen, choose which options you would like to use.
3. After completing the selections, choose “OK” to make all your selections effective.
4. After complete setup, the power\_saver would take effect as you request when time up and you may continue your normal process.

## 1.2.4 Zoom\_Key Setup

In “SiS VGA Configuration System” screen, choose “zooming” item to define “hot keys” for zoom-in or zoom-out screen without entering setup program.

**The operation principles of zoom-in and zoom-out are as follow:**

- (1) The resolution change sequence for zoom-in is  
1024x768 ==> 800x600 ==> 640x480 .
- (2) The resolution change sequence for zoom-out is  
640x480 ==> 800x600 ==> 1024x768 .
- (3) But you must first be able to zoom-in before you may zoom-out, that means you can not get a resolution larger than that you setup.

**To use this feature, please follow the following procedures.**

1. In “SiS VGA Configuration System” screen, choose “zooming” item to enter “Zooming Hotkey” screen.
2. In “Zooming Hotkey” Screen, choose which “hot key” you would like to use and enable it.
3. After completing the selections, choose “OK” to make all your selections effective.
4. After complete setup, you may use your own defined hot key to zoom-in or zoom-out screen.

## 1.2.5 Notes

1. The power saver’s timer settings would be effective even exit Windows back to DOS.

# IX. SOFTWARE DRIVERS

---

## 1.3 Video Operations

### 1.3.1 DCI Function

SiS 5597/5598 supports DCI driver for software MPEG playback and other media player programs which could take advantage of DCI.

The SiS 5597/5598 DCI driver is automatically loaded during “Windows Driver Unpack & Copy” process. Therefore it should be transparent to the end-user and any media players could take advantage of it.

### 1.3.2 SiS MMPlay (SW MPEG)

To make SW MPEG playback more friendly than original SW MPEG player supplier provided, SiS provide an MMPlayer application program to provide an VCP-like (Video Cassette Player) interface.

To take advantage of the SiS MMPlayer, you must first install “SW MPEG Player”. All the SiS provided is just an interface but not a SW MPEG Player at present. If the SW MPEG Player does not exist, the SiS MMPlayer will not work. (Xing or Mediamatics SW MPEG Player supported)

**To use the SiS MMPlayer, you just follow the procedures below:**











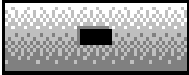



1. In “SiS Multimedia Vx.xx” program group, choose “SiS MMPlayer” icon and SiS MMPlayer VCP-like icon would appear.
2. Enjoy the SW MPEG playback as you like.

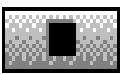

# IX. SOFTWARE DRIVERS

---

## *MMPLAY.EXE Button Description*

	: Power On/Off
	: Open File & Type Control
	: Minimize This Application
	: Eject CD Title (Not implemented yet.)
	: Fast Backward
	: Fast Forward
	: Mark in
	: Mark out
	: Pause
	: Play
	: Stop
	: End
	: Begin
	: Volume increase (Not implemented yet.)
	: Volume decrease (Not implemented yet.)

---

(This page was intentionally left blank)

# IX. SOFTWARE DRIVERS

---

## 2. Windows 95

### 2.0 Version Note

The following description apply to “SiS 5597/5598 Driver Release V1.03” and maybe later release version but not guaranteed.

### 2.1 Driver Files

1. The enclosed SiS 5597/5598 Windows 95 drivers files are:  
**SETUP.EXE**                    **SIS597.DRV**                    **SIS597.INF**  
**SISMINI.VXD**                    **Other Files**
2. All the 16-color, 256-color, 32K/64K-color, and 16M-color drivers are available.

### 2.2 Installation

1. Boot up Windows 95.
2. In Windows 95 “Booted” Screen, select “My Computer” icon.
3. In “My computer” Screen, select “Control Panel” icon.
4. In “Control Panel” Screen, select “Display” icon.
5. In “Display Properties” Screen, select “Settings” item.
6. In refreshed “Display Properties” Screen, select “Change Display\_Type” item.
7. In “Change Display Type” Screen, select “Adapter Type ==> Change” item.
8. In “Select Device” Screen, select “Have Disk...” item.
9. In “Install From Disk” Screen, select your driver source.e.g. A:\WIN95
10. In new “Select Device” Screen, “SiS 5597/5598” would appear and select “OK”. Then Windows 95 would perform driver installation.
11. After completing installation, Windows 95 would go back to “Change Display Type” Screen, select “Close” item.
12. Windows 95 would go back to “Display Properties” Screen, select “Close” or “Apply” item.
13. In “System Settings Change” Screen, select “Yes” item to restart your computer.
14. After restarting, Windows 95 will run on 640x480x256 color, 60NI.

# IX. SOFTWARE DRIVERS

---

## 2.3 Using “Display Modes”

1. Go to “Display Properties” Screen and you will find that “Display Modes” item had been added.
2. First select “Display Modes” item and you may select desired resolution by changing “Desktop area” pointer, desired color by changing “Color palette” value, desired font size by changing “Font size”, and desired refresh rate by changing “Refresh rate”.
3. After completing selection, select “OK” or “Apply” to complete the whole installation.
4. In “SiS 5597/5598 Settings” Screen, select “OK”.
5. Two cases happen :
  - a). You did not change “color” and/or “font size”.
    1. “SiS 5597/5598 Settings” Screen appears again,
    2. Select “Yes” and you may work on your selected mode now.
  - b). You changed “color” and/or “font size”.
    1. System will reboot.
    2. You may work on your selected mode now.

# IX. SOFTWARE DRIVERS

---

## 2.4 Utilities

### 2.4.1 Installation

1. From “Start Menu”, select “Run” item.
2. In “Run” Screen, select your source execution file.  
e.g. D:\MM\WIN95\SETUP.EXE
3. In “SiS Multimedia Setup Ver x.xx”, select “OK”.
4. A “SiS Multimedia Vx.xx” program group would be created and shown on screen, select “Restart Now”.
5. In the “SiS Multimedia Vx.xx” program group, there are three icons:
  - (1) SiS Multimedia Package: To create a small “SiS Multimedia” icon on the corner of the screen.
  - (2) SiS MMPlayer: To create a “SiS MMPlayer” VCP-like icon on the screen.
  - (3) Center Screen: An utility to adjust the position of display on the screen.
6. “SiS Multimedia V x.xx” program group has been created, select “Restart Now”.

### 2.4.2 Operation

1. For Video Operations (“SiS MMPlayer”), please refer to section 1.3.

# IX. SOFTWARE DRIVERS

---

## 3. Windows NT 3.5 & 3.51

### 3.0 Version Note

The following description apply to “SiS 5597/5598 Driver Release V1.03” and maybe later release version but not guaranteed.

### 3.1 Driver Files

(1) The enclosed SiS 5597/5598 Windows NT 3.5 & 3.51 drivers are:

SISTAG	SISV.SYS	SISV256.DLL
SISV.DLL	OEMSETUP.INF	

(2) All the 16-color, 256-color, 32K/64K-color, and 16M-color drivers are available.

### 3.2 Installation

1. Select Control Panel from Main group.
2. Select Display icon.
3. Select Change Display Type from Display Settings.
4. Select Change from Display Type.
5. Select Other from Select Device.
6. Place the SiS 5597/5598 CD-title Disk into CD-ROM Drive.
7. When the “Install from Disk” dialog box appears, type the directory storing the drivers and click “OK”.  
The directory in CD-Title is at “D:\MM\WINNT\WINNT35”.
8. Select Install and click “Yes” when the “Installing Driver” dialog box appears.
9. Select New when the “Windows NT Setup” dialog box appears.
10. Click “Continue” - A message will appear stating that the drivers were successfully installed. Click “OK”. You must now restart Windows NT 3.51.

### 3.3 Selecting resolution and color depth

1. Select Control Panel from Main group.
2. Select Display icon.
3. Select Color Palette to change between 16 colors, 256 colors, 32768 colors, 65536 colors, and 16777216 colors.
4. To select desktop resolution size, go to the Desktop area and use the slide bar to change resolution from 640x480, 800x600, 1024x768, and 1280x1024.
5. Select Test to test the resolution.  
If the display test screen was good then select “Yes” when the “Testing Mode” dialog box appears. If the display test screen was bad then select “No”. Windows NT will give you an error message.
6. If the display test screen was good and you select “Yes”, Windows NT 3.51 will prompt you to restart Windows NT 3.51.

# IX. SOFTWARE DRIVERS

---

## 4. Windows NT 4.0

### 4.0 Version Note

The following description apply to “SiS 5597/5598 Driver Release V1.03” and maybe later release version but not guaranteed.

### 4.1 Driver Files

(1) The enclosed SiS 5597/5598 Windows NT 4.0 drivers are:

SISV.SYS	SISV256.DLL
SISV.DLL	SISV5597.INF

(2) All the 16-color, 256-color, 32K/64K-color, and 16M-color drivers are available.

### 4.2 Installation

1. Click “Start” menu and select Control Panel from Settings group.
2. Select Display icon.
3. Select Settings of Display Properties.
4. Select Display Type.
5. Select Change from the Adapter Type area.
6. Select Have Disk of Change Display.
7. Place the SiS 5597/5598 CD-Title Disk into CD-ROM Drive.
8. When the “Install from Disk” dialog box appears, type the directory storing the drivers and click “OK”.  
The directory in CD-Title is at “D:\MM\WINNT\WINNT40”.
9. When the “Change Display” dialog box appears, click “OK”.
10. When the “Third-party Drivers” dialog box appears, click “Yes” - A message will appear stating that the drivers were successfully installed.
11. Click “OK”. You must now restart Windows NT 4.0.

### 4.3 Selecting resolution and color depth

1. Click “Start” menu and select Control Panel from Settings group.
2. Select Display icon.
3. Select Settings.
4. Select Color Palette to change between 16 colors, 256 colors, 32768 colors, 65536 colors, and 16,777,216 colors.
5. To select desktop resolution size, go to the Desktop area and use the slide bar to change resolution from 640x480, 800x600, 1024x768, and 1280x1024.
6. Select Test to test the resolution. If the display test screen was good then select “Yes” when the “Testing Mode” dialog box appears. If the display test screen was bad then select “No”. Windows NT 4.0 will give you an error message.
7. Click “OK”. If the display test screen was good and you select “Yes”, Windows NT 4.0 will change the mode without restarting Windows NT 4.0.

# IX. SOFTWARE DRIVERS

---

## 5. Autodesk ADI 4.2 -Protected Mode

### 5.0 General Description

#### 5.0.1 Driver Files

1. The enclosed SiS 5597/5598 ADI driver contains the following file:  
**RCPSIS.EXP** SiS ADI Driver (for all resolutions & colors)  
Note: This version of ADI driver does not support 16-color operation.
2. This driver fits for a series of Autodesk Inc. products including:
  - (1) AutoCAD/386 R11
  - (2) AutoCAD/386 R12
  - (3) AutoShade/386 V2.0
  - (4) 3D Studio V3.0
3. Their installation procedures are different from one program to the others. But the first step of installation is the same for all these programs, that is “To unpack and copy drivers to where you would like them to reside.” Therefore, we will state this step below.
4. As to the real installation procedures for each program, we will give a detail description in Sec. 5.1 to Sec. 5.4.

#### 5.0.2 Unpack & Copy

To unpack and copy drivers to where they should reside, please follow the following procedures:

1. Run “INSTDRV.EXE” where it resides.
2. In “SiS Super VGA Drivers Installation” menu, select “A. ADI 4.2” to unpack and copy drivers. (To select, type “A”)
3. In “Unpack & Copy ADI 4.2 Drivers” screen, **keyin the “drive:\directory” where these drivers would reside** (default C:\ADI42). Program would unpack & copy all related driver files to where you assign.
4. After “unpack and copy” completed, exit the INSTDRV.EXE program.
5. Refer to Sec. 5.1 to Sec. 5.4 for the real installation procedures for each program.



# IX. SOFTWARE DRIVERS

---

## 5.1 AutoCAD R11 Setup

1. The following procedures assume that
  - (1) You have complete “unpack & copy” procedure.
  - (2) Your ADI 4.2 drivers are located in C:\ADI42.
2. Add the following setting to your own batch file for AutoCAD R11 (say ACADR11.BAT) or to your “AUTOEXEC.BAT” file:  
SET DSPADI=\ADI42\RCPSIS.EXP <Enter>
3. Delete the configure file ACAD.CFG resides in \ACAD directory.
4. Type ACADR11 <Enter> to configure your AutoCAD R11 system.
5. In “Select Display Device:” item, choose “ADI P386 V4.0/4.1 display”
6. In “Select Display Resolution” screen, choose which display driver you want to use.
7. Go through the whole instructions, and the system would start with the desired display setting.

# IX. SOFTWARE DRIVERS

---

## 5.2 AutoCAD R1.2 Setup

1. The following procedures assume that
  - (1) You have complete “unpack & copy” procedure.
  - (2) Your SiS ADI 4.2 drivers are located in C:\ADI42.
  - (3) Your AutoCAD R12 program is located in C:\ACADR12.
  - (4) Your AutoCAD R12 default drivers are located in C:\ACADR12\DRV.
  - (5) Your AutoCAD R12 configure file ACAD.CFG is located in C:\ACADR12.
2. Copy the following driver file to C:\ACADR12\DRV: RCPSIS.EXP.  
You may complete this step by COPY C:\ADI42\RCPSIS.EXP C:\ACADR12\DRV.
3. Delete your original ACAD.CFG file. You may complete this step by DEL C:\ACADR12\ACAD.CFG.
4. Restart your AutoCAD R12 program as usual.
5. AutoCAD R12 will ask you to complete the configuration procedures since it can't find the configure file ACAD.CFG.
6. Follow the instructions of AutoCAD R12 to proceed configuration.
7. In “Available Video Displays:” item, choose the “SiS Super VGA ADI v4.2 Display and Rendering driver” item.
8. In “Select Display Resolution” screen, choose which display driver you want to use.
9. Go through the whole instructions, and the system would start with the selected display setting.

# IX. SOFTWARE DRIVERS

---

## 5.3 AutoShade R2.0 Setup

1. The following procedures assume that
  - (1) You have complete “unpack & copy” procedure.
  - (2) Your ADI 4.2 drivers are located in C:\ADI42.
2. Add the following settings to your batch file for AutoShade R2.0 (say SHADE2.BAT) or to your “AUTOEXEC.BAT” file.
  - (a) For display driver setting, SET DSPADI=\ADI42\RCPSIS.EXP.
  - (b) For rendering driver setting, SET RDPADI=\ADI42\RCPSIS.EXP.
3. Delete the configure file SHADE.CFG.
4. Type SHADE2 <Enter> to re-configure the AutoShade.
5. While prompting “Select display device:”, choose “P386 AutoDesk Device Interface display driver.”
6. While prompting “Select rendering display driver:”, choose “P386 AutoDesk Device Interface rendering driver.”
7. Go through all the instructions, the system would start with the desired display setting.

# IX. SOFTWARE DRIVERS

---

## 5.4 3D Studio Version 3.0 Setup

1. The following procedures assume that
  - (1) You have complete “unpack & copy” procedure.
  - (2) Your ADI 4.2 drivers are located in C:\ADI42.
2. Create your own **3D Studio V3.0 batch file** (say **3DS3.BAT**) and add the following settings to it, or add the following settings to your “**AUTOEXEC.BAT**” file.
  - (1) **SET RCPADI=C:\ADI42\RCPSIS.EXP**
  - (2) **SET RDPADI=C:\ADI42\RCPSIS.EXP**
3. Execute the new 3DS batch file or reboot the computer using the new “**AUTOEXEC.BAT**” as to make the new settings effective.
4. Change your current working directory to \3DS3 (where your 3D Studio V3.0 usually resides).
5. Delete original configuration file “3DADI.CFG”.
6. Type **3DS VIBCGF** <Enter> to configure your display environment.
7. After the “Company Register Screen” appears, press <Enter> to continue.
8. The “Video Environment Configuration Screen” will appear.

Please follow the following procedures to configure your video display environment.

- (1) In “Main-Display” item,
  - (a) Press <Enter> The selection menu will appear.
  - (b) In selection menu, move cursor to “**RCPADI**”. Press <Enter> to select.
- (2) In “Material-Display” item,
  - (a) Press <Enter> The selection menu will appear.
  - (b) In selection menu, move cursor to “**RCPADI**”. Press <Enter> to select.
- (3) In “Render-Display” item,
  - (a) Press <Enter> The selection menu will appear.
  - (b) In selection menu, move cursor to “**RCPADI**” or “**RDPADI**”. Press <Enter> to select.
- (4) Complete the other selections and exit configuration.

# IX. SOFTWARE DRIVERS

---

9. After exit configure, 3DS will boot automatically using the environment you just select.
10. If your previous configuration is OK, 3DS will ask you to make detail configuration for SiS 5597/5598 drivers. If this didn't happen, please check your previous procedures or contact the technical support people.
11. In the detail configuration for SiS 5597/5598 drivers, just follow the instructions appear on the screen and make your own choice. If you are confused in anything, contact the technical support people for solution.
12. After detail configuration, you will enter the 3DS main display screen and you may begin your 3D Studio work in the environment you make before.
13. Once completing the detail configuration, you may enter 3D Studio in the same configuration simply by type `\3DS\3DS <Enter>` next time.
14. If you want to change your video configuration, just follow the procedures mentioned before to re-configure.

# IX. SOFTWARE DRIVERS

---

## 6. OS/2 V2.1

### 6.0 Driver Notes

1. The following description apply to “SiS 5597/5598 Driver Release V1.03” and maybe later release version but not guaranteed.

### 6.1 Driver Files

1. The enclosed SiS 5597/5598 OS/2 2.1 driver contains the following files:

<b>SISINST.COMD</b>	SiS driver install program
<b>SVGA.EXE</b>	SiS PMI Generator
<b>S768256.DL@</b>	SiS IBMDEV32.DLL Display Driver
<b>OTHERS</b>	other files required during installation

### 6.2 Installation

Before install SiS 5597/5598 OS/2 drivers, make sure:

1. Install your OS/2 system using “**VGA display**” option (i.e. standard VGA).
2. Start your OS/2 system.

#### **Install SiS 5597/5598 OS/2 2.1 drivers as following procedures:**

1. Enter “OS/2 window” or “OS/2 full screen”.
2. Change directory to which holds the SiS 5597/5598 OS/2 2.1 display drivers and type `SISINST <Enter>`.  
For example, `A:\OS2\SBCS.21>SISINST`
3. All the Driver Files will be copied to a subdirectory `C:\SISDRV` and the “Select Screen parameters for SiS SVGA” menu appears and all the resolution (and color) and frame rate supported would be shown on the screen.
4. Choose which one you would like to use and click “OK”.
5. Then installation program would complete all installation process and create a “SiS Setup” for future change mode usage.
6. Shutdown and re-boot OS/2 to make your selection effectively.

# IX. SOFTWARE DRIVERS

---

## 7. OS/2 V3.0 (Warp)

### 7.0 Driver & OS/2 Version Notes

1. The following description apply to “SiS 5597/5598 Driver Release V1.03” and maybe later release version but not guaranteed.
2. All the OS/2 Warp Versions up to SiS 5597/5598 driver Rev. 1.03 would be installed as described in this section except for Double Bytes OS/2 Warp (i.e. Chinese, Japanese, Korea, etc.).
3. For Double Bytes OS/2 Warp installation, please refer to “Sec. 8 Double Bytes OS/2 Warp”.

### 7.1 Driver Files

**The enclosed SiS 5597/5598 OS/2 3.0 driver contains the following files:**

<b>SISINST.CMD</b>	SiS driver install program
<b>SVGA.EXE</b>	SiS PMI Generator
<b>S768256.DL@</b>	SiS IBMDEV32.DLL Display Driver
<b>OTHERS</b>	other files required during installation

### 7.2 Installation

**Before install SiS 5597/5598 OS/2 drivers, make sure:**

1. Install your OS/2 system using “**VGA display**” option (i.e. standard VGA).
2. Start your OS/2 system.

**Install SiS 5597/5598 OS/2 Warp drivers as following procedures:**

1. Enter “OS/2 window” or “OS/2 full screen”.
2. Change directory to which holds the SiS 5597/5598 OS/2 3.0 display drivers and type SISINST <Enter>. For example, A:\OS2\SBCS.30>SISINST
3. All the Driver Files will be copied to a subdirectory C:\SISDRV and the “Select Screen parameters for SiS SVGA” menu appears and all the resolution (and color) and frame rate supported would be shown on the screen.
4. Choose which one you would like to use and click “OK”.
5. Then installation program would complete all installation process and create a “SiS Setup” for future change mode usage.
6. Shutdown and re-boot OS/2 to make your selection effectively.

# IX. SOFTWARE DRIVERS

---

## 8. Double Bytes OS/2 Warp

### 8.0 Driver & OS/2 Version Notes

1. The following description apply to “SiS 5597/5598 Driver Release V1.03” and maybe later release version but not guaranteed.
2. The following description apply to “Double Bytes OS/2 Warp” only. (i.e. Chinese, Japanese, Korea, etc.)

### 8.1 Driver Files

The enclosed SiS 5597/5598 Double Byte OS/2 3.0 driver contains the following files:

<b>SETUP.CMD</b>	SiS driver install program
<b>SVGA.EXE</b>	SiS PMI Generator
<b>S768256.DL@</b>	SiS IBMDEV32.DLL Display Driver
<b>OTHERS</b>	other files required during installation



# IX. SOFTWARE DRIVERS

---

## 8.2 Installation

**For Double Byte OS/2 Warp limitation, the installation process is a two phase installation and can't complete the whole installation in one-time-process.**

**1st phase:** copy files, modify “config.sys”, create “SiS Install” icon then shutdown and re-boot OS/2.

**2nd phase:** double clicks “SiS Install” icon to complete the installation

**Before install SiS 5597/5598 OS/2 drivers, make sure:**

1. Install your OS/2 system using “VGA display” option (i.e. standard VGA).
2. Start your OS/2 system.

**Install SiS 5597/5598 OS/2 Warp drivers as following procedures:**

**1st phase:**

1. Enter “OS/2 window” or “OS/2 full screen”.
2. Change directory to which holds the SiS 5597/5598 OS/2 3.0 display drivers and type SETUP <Enter>, For example, A:\OS2\DBCS.30>SETUP
3. All the Driver Files will be copied to a subdirectory C:\SISDRV and “SiS Install” icon would be created.
4. After completing “setup” program, shutdown and re-boot OS/2.

**2nd phase:**

5. After re-booting OS/2, double clicks “SiS Install” icon. Then the “SiS Install” icon would be executed automatically and “Select Screen parameters for SiS SVGA” screen would appeared on the screen.
6. Select the desired resolution (and color) and frame rate on this screen, then click “OK” to complete installation and “SiS Setup” icon would be created for future change modes and frame rate usage.
7. After completing installation, shutdown and re-boot OS/2 to make your selection effectively.

---

(This page was intentionally left blank)