

BI440ZX Motherboard Product Guide

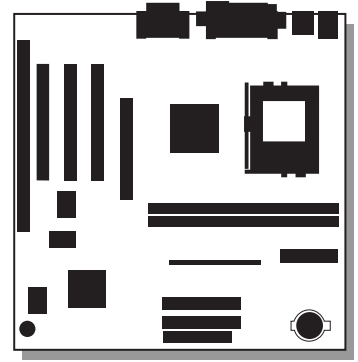

Order Number: 726091-002

Revision History

Revision	Revision History	Date
001	First release of the BI440ZX Motherboard Product Guide.	October 1998
002	Second release of the BI440ZX Motherboard Product Guide. Added BIOS Setup Program Screen chapter.	December 1998

If an FCC declaration of conformity marking is present on the board, the following statement applies:

FCC Declaration of Conformity

This device complies with Part 15 of the FCC Rules. Operation is subject to the following two conditions: (1) this device may not cause harmful interference, and (2) this device must accept any interference received, including interference that may cause undesired operation.

For questions related to the EMC performance of this product, contact:

Intel Corporation
5200 N.E. Elam Young Parkway
Hillsboro, OR 97124
1-800-628-8686

This equipment has been tested and found to comply with the limits for a Class B digital device, pursuant to Part 15 of the FCC Rules. These limits are designed to provide reasonable protection against harmful interference in a residential installation. This equipment generates, uses, and can radiate radio frequency energy and, if not installed and used in accordance with the instructions, may cause harmful interference to radio communications. However, there is no guarantee that interference will not occur in a particular installation. If this equipment does cause harmful interference to radio or television reception, which can be determined by turning the equipment off and on, the user is encouraged to try to correct the interference by one or more of the following measures:

- Reorient or relocate the receiving antenna.
- Increase the separation between the equipment and the receiver.
- Connect the equipment to an outlet on a circuit other than the one to which the receiver is connected.
- Consult the dealer or an experienced radio/TV technician for help.

Canadian Department of Communications Compliance Statement:

This digital apparatus does not exceed the Class B limits for radio noise emissions from digital apparatus set out in the Radio Interference Regulations of the Canadian Department of Communications.

Le présent appareil numérique n'émet pas de bruits radioélectriques dépassant les limites applicables aux appareils numériques de la classe B prescrites dans le Règlement sur le brouillage radioélectrique édicté par le ministère des Communications du Canada.

Disclaimer

Intel Corporation (Intel) makes no warranty of any kind with regard to this material, including, but not limited to, the implied warranties of merchantability and fitness for a particular purpose. Intel assumes no responsibility for any errors that may appear in this document. Intel makes no commitment to update nor to keep current the information contained in this document. No part of this document may be copied or reproduced in any form or by any means without prior written consent of Intel.

An Intel product, when used in accordance with its associated documentation, is "Year 2000 Capable" when, upon installation, it accurately stores, displays, processes, provides, and/or receives date data from, into, and between the twentieth and twenty-first centuries, including leap year calculations, provided that all other technology used in combination with said product properly exchanges date data with it.

† Third-party brands and trademarks are the property of their respective owners.

Copyright © 1998, Intel Corporation. All Rights Reserved

Contents

1 Motherboard Features

Feature Summary.....	7
Components.....	8
Microprocessor.....	9
Main Memory	9
PCI Enhanced IDE Interface	10
Input/Output (I/O) Controller.....	10
Real-Time Clock.....	11
USB Support	11
Accelerated Graphics Port (AGP).....	12
BIOS	12
Expansion Slots.....	12
Power Management	13
Battery.....	13
Wake on Ring / Resume on Ring Technologies (Optional).....	13
Wake on LAN Technology.....	14
Audio Subsystem (Optional).....	14
Speaker (Optional)	14

2 Installing and Replacing Motherboard Components

Before You Begin	15
How to Install and Remove the Motherboard.....	16
How to Install a Celeron Processor	17
How to Remove a Celeron Processor.....	20
How to Install Memory	20
How to Remove Memory	21
How to Replace the Battery.....	22

3 Using the BIOS Setup Program

BIOS Setup Program Modes	25
Function Keys.....	26
How to Access the BIOS Setup Program	26
How To Upgrade the BIOS.....	27
Obtaining the BIOS Upgrade File.....	27
Recording the Current BIOS Settings	27
Creating a Bootable Diskette	28
Creating the BIOS Upgrade Diskette	28
Performing the BIOS Upgrade.....	29
How to Recover the BIOS	29
How to Change the BIOS Language	30
How to Clear the Passwords	31

4 BIOS Setup Program

Maintenance Menu	33
Main Menu	34
Advanced Menu	35
Boot Setting Configuration Submenu	35
Peripheral Configuration Submenu	36
IDE Configuration	38
IDE Configuration Submenus	39
Diskette Configurations Submenu.....	40
Event Log Configuration	40
Video Configuration Submenu	41
Resource Configuration Submenu	41
Security Menu	41
Power Menu	42
Boot Menu.....	43
Exit Menu	44

5 Technical Reference

Motherboard Connectors.....	45
Back Panel Connectors	46
Midboard Connectors	47
Front Panel Connector.....	48
Jumper Blocks.....	49
BIOS Setup Configuration Jumper Block	49
USB Port 0 Configuration Jumper Block (Optional).....	50

A Error Messages

BIOS Beep Codes	51
BIOS Error Messages	51

B Regulatory and Integration Information

Regulatory Compliance	53
Installation Precautions	54
Installation Instructions	54
Ensure Electromagnetic Compatibility (EMC)	55
Ensure Chassis and Accessory Module Certifications	55
Prevent Power Supply Overload.....	56
Place Battery Marking on the Computer	56
Use Only for Intended Applications.....	56

Figures

1. Motherboard Components	8
2. Mounting Screw Holes.....	16
3. Raising the Socket Handle.....	17
4. Inserting the Processor Into the Socket	17
5. Closing the Handle	18
6. Attaching the Heatsink to the Processor	18
7. Attaching the Fan Heatsink Clip.....	19

8.	Connecting the Processor Fan Cable to the Processor Fan Connector	19
9.	Installing a DIMM	21
10.	Removing the Battery	23
11.	Connector Groups	45
12.	Back Panel Connectors	46
13.	Midboard Connectors	47
14.	Front Panel Connector.....	48
15.	Location of the Jumper Blocks.....	49

Tables

1.	Processors Supported by the Motherboard	9
2.	Supported Memory Sizes and Configurations.....	9
3.	Jumper Settings for BIOS Setup Program Modes.....	25
4.	Setup Menu Bar.....	26
5.	Setup Function Keys.....	26
6.	BIOS Setup Program Menu Bar.....	33
7.	Maintenance Menu	33
8.	Main Menu.....	34
9.	Advanced Menu.....	35
10.	Boot Setting Configuration Submenu.....	35
11.	Peripheral Configuration Submenu	36
12.	IDE Device Configuration	38
13.	IDE Configuration Submenus	39
14.	Diskette Configurations Submenu	40
15.	Event Log Configuration Submenu	40
16.	Video Configuration Submenu	41
17.	Resource Configuration Submenu	41
18.	Security Menu.....	41
19.	Power Menu	42
20.	Boot Menu	43
21.	Exit Menu	44
22.	BIOS Setup Configuration Jumper Settings.....	49
23.	USB Port 0 Configuration Jumper Settings.....	50
24.	Beep Codes.....	51
25.	BIOS Error Messages.....	51
26.	Safety Regulations	53
27.	EMC Regulations.....	53

1 Motherboard Features

This chapter gives an overview of the BI440ZX motherboard. The remaining chapters discuss:

- How to add or upgrade components like processors or memory
- How to invoke the BIOS Setup program to modify the motherboard's configuration
- How to upgrade the BIOS
- The contents of the BIOS Setup Program's screens
- The locations of the connectors

Feature Summary

Form Factor	microATX (9.6 inches by 9.6 inches)
Processor	Support for socketed Intel® Celeron™ processors with 66-MHz host bus speed
Memory	<ul style="list-style-type: none">• Two 168-pin dual inline memory module (DIMM) sockets• Supports up to 256 MB of 66 MHz synchronous DRAM (SDRAM)
Chipset	Intel® 82440ZX AGPset, consisting of: <ul style="list-style-type: none">• Intel® 82443ZX PCI/AGP controller (PAC)• Intel® 82371EB PCI ISA IDE Xcelerator (PIIX4E)
I/O Control	SMSC FDC37M807 I/O controller
Peripheral Interfaces	<ul style="list-style-type: none">• Two serial ports• Two Universal Serial Bus (USB) ports• One parallel port• Two IDE interfaces with Ultra DMA support• One diskette drive interface
Video	One Accelerated Graphics Port (AGP) connector
Expansion capabilities	Three available add-in card expansion slots: <ul style="list-style-type: none">• Two dedicated PCI bus add-in card connectors• One shared slot for either a PCI bus or an ISA bus add-in card
BIOS	<ul style="list-style-type: none">• Intel/AMI BIOS• Intel® E28F200B5 2 Mbit flash memory• Support for Advanced Power Management (APM), Advanced Configuration and Power Interface (ACPI), Plug and Play, and SMBIOS
Audio (optional)	AC '97 compatible audio subsystem, consisting of: <ul style="list-style-type: none">• Creative Sound Blaster† AudioPCI 64V AC '97 Digital Controller• CS4297 audio codec

⇒ NOTE

For information about Intel® motherboards, including technical product specifications, BIOS upgrades, and device drivers, see “Products” at the Intel World Wide Web site:

<http://support.intel.com/support/motherboards/desktop>

Components

Figure 1 shows the major components on the motherboard.

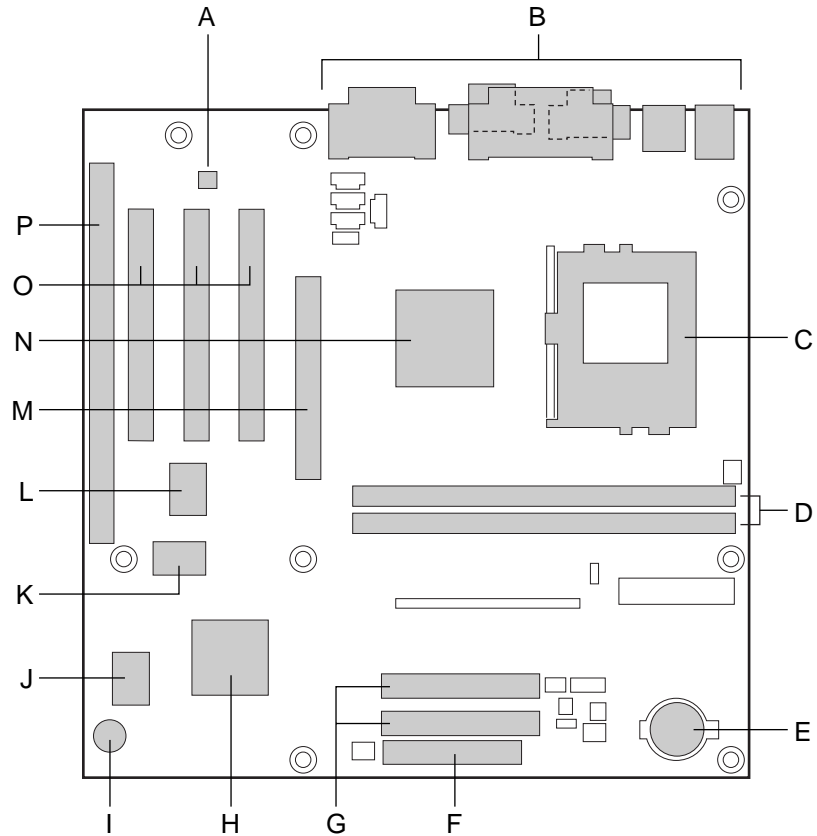

OM07463

A	CS4297 audio codec (optional)	I	Speaker
B	Back panel connectors	J	SMSC FDC37M807 I/O controller
C	Processor socket	K	Flash memory
D	DIMM sockets	L	Creative Sound Blaster AudioPCI 64V AC '97 Digital Controller (optional)
E	Battery	M	AGP connector
F	Diskette drive connector	N	Intel 82443ZX PAC
G	IDE connectors	O	PCI bus add-in card connectors
H	Intel 82371EB PIIX4E	P	ISA bus add-in card connector

Figure 1. Motherboard Components

⇒ NOTE

Components labeled optional do not come on all BI440ZX motherboards.

Microprocessor

The motherboard supports the socketed Celeron processors listed in Table 1. All supported onboard memory can be cached.

Table 1. Processors Supported by the Motherboard

Processor Speed	Host Bus Frequency	Cache Size
300A MHz	66 MHz	128 KB
333 MHz	66 MHz	128 KB

For information about	Refer to
Installing a processor	Page 17
Processor support for the BI440ZX motherboard	http://support.intel.com/support/motherboards/desktop

Main Memory

The motherboard has two sockets for installing DIMMs. Minimum memory size is 16 MB; maximum memory size is 256 MB. The motherboard supports the following memory features:

- 168-pin SPD or non-SPD DIMMs with gold-plated contacts
- 66 MHz or 100 MHz unbuffered SDRAM
- 64-bit (non-ECC) memory
- 3.3 V memory only
- Single- or double-sided DIMMs in the sizes listed in Table 2

Table 2. Supported Memory Sizes and Configurations

DIMM Size	Configuration
16 MB	2 Mbit x 64
32 MB	4 Mbit x 64
64 MB	8 Mbit x 64
128 MB	16 Mbit x 64

For information about	Refer to
Installing memory	Page 20

⇒ NOTE

The board is compatible with both 66 MHz and 100 MHz DIMMs, but installing faster speed memory will not increase system performance (owing to the 66 MHz host bus frequency).

PCI Enhanced IDE Interface

The PCI enhanced IDE interface handles the exchange of information between the processor and peripheral devices like hard disks and add-in boards inside the computer. The interface supports:

- Up to four IDE devices (such as hard drives)
- ATAPI devices (such as CD-ROM drives)
- PIO Mode 3 and PIO Mode 4 devices
- Ultra DMA/33
- Logical block addressing (LBA) of hard drives larger than 528 MB and extended cylinder head sector (ECHS) translation modes
- Support for laser servo (LS-120) drives

For information about	Refer to
The location of the IDE connectors	Figure 13, page 47
The PIIX4E PCI IDE controller	<i>BI440ZX Motherboard Technical Product Specification</i> available through: http://support.intel.com/support/motherboards/desktop

Input/Output (I/O) Controller

The I/O controller handles the exchange of information between the processor and external devices like the mouse and keyboard or a printer that are connected to the computer. The controller features the following:

- Integrated keyboard and mouse controller
- Industry standard diskette drive controller
- One multimode bi-directional parallel port
 - Standard mode: Centronics-compatible operation
 - High speed mode: support for Extended Capabilities Port (ECP) and Enhanced Parallel Port (EPP)
- Two serial ports
- Flexible IRQ and DMA mapping for Windows[†] 95 and Windows 98

For information about	Refer to
The location of the keyboard, mouse, parallel, and serial ports	Figure 12, page 46
The I/O controller device	<i>BI440ZX Motherboard Technical Product Specification</i> available through: http://support.intel.com/support/motherboards/desktop

Real-Time Clock

The motherboard has a time-of-day clock and 100-year calendar that will rollover to 2000 at the turn of the century. A battery on the motherboard keeps the clock current when the computer is turned off.

⇒ NOTE

The recommended method of accessing the date in systems with Intel motherboards is indirectly from the Real-Time Clock (RTC) via the BIOS. The BIOS on Intel motherboards and baseboards contains a century checking and maintenance feature that checks the least two significant digits of the year stored in the RTC during each BIOS request (INT 1Ah) to read the date and, if less than 80 (i.e., 1980 is the first year supported by the PC), updates the century byte to 20. This feature enables operating systems and applications using the BIOS date/time services to reliably manipulate the year as a four-digit value.

For information about	Refer to
Proper date access in systems with Intel motherboards	http://support.intel.com/support/year2000/paper.htm

USB Support

The motherboard has two USB ports. You can connect two USB peripheral devices directly to the computer without an external hub. To attach more than two devices, connect an external hub to either of the built-in ports. The motherboard supports the standard universal host controller interface (UHCI) and takes advantage of standard software drivers written to be compatible with UHCI.

For information about	Refer to
The location of the USB ports	Figure 12, page 46
USB legacy support in the BIOS	<i>BI440ZX Motherboard Technical Product Specification</i> available through: http://support.intel.com/support/motherboards/desktop

⇒ NOTE

Computer systems that have an unshielded cable attached to a USB port might not meet FCC Class B requirements, even if no device or a low-speed USB device is attached to the cable. Use a shielded cable that meets the requirements for a high-speed USB device.

Accelerated Graphics Port (AGP)

The AGP is a high-performance bus for graphics-intensive applications, such as 3D graphics. AGP is independent of the PCI bus and is intended for exclusive use with graphical display devices.

For information about	Refer to
The location of the AGP connector	Figure 1, page 8
Features of the AGP interface	<i>BI440ZX Motherboard Technical Product Specification</i> available through: http://support.intel.com/support/motherboards/desktop

BIOS

The motherboard's system BIOS is contained in a flash memory device on the motherboard. The BIOS provides the power-on self test (POST), the BIOS Setup program, and the PCI and IDE auto-configuration utilities.

For information about	Refer to
Accessing, upgrading, or recovering the BIOS	Chapter 3, beginning on page 25
The contents of the BIOS Setup Program's screens	Chapter 4, beginning on page 33
BIOS support for: <ul style="list-style-type: none"> • PCI and ISA Plug and Play • System Management BIOS (SMBIOS) • Power management • Boot options • USB legacy support • Security features 	<i>BI440ZX Motherboard Technical Product Specification</i> available through: http://support.intel.com/support/motherboards/desktop

Expansion Slots

The motherboard has four expansion slots for installing add-in boards, such as network cards, that expand the capabilities of your computer. The expansion slots are as follows:

- One shared PCI/ISA slot
- Two PCI slots
- One AGP slot

Power Management

The motherboard supports two types of power management — Advanced Power Management (APM) and Advanced Configuration and Power Interface (ACPI). If the board is used with an ACPI-aware operating system, the BIOS provides ACPI support. Otherwise, it defaults to APM support.

For information about	Refer to
How the board supports APM and ACPI	<i>BI440ZX Motherboard Technical Product Specification</i> available through: http://support.intel.com/support/motherboards/desktop

Battery

A battery on the motherboard keeps the clock and the values in CMOS RAM current when your computer is turned off.

For information about	Refer to
The location of the battery	Figure 1, page 8
How to replace the battery	Page 22

Wake on Ring / Resume on Ring Technologies (Optional)

The board supports two technologies that enable telephony devices (such as modems) to access the computer when it is in a power-managed state. The method used depends on the type of telephony device (external or internal) and the power management mode being used (APM or ACPI). The optional Wake on Ring connector is used to implement this feature.

For information about	Refer to
The location of the Wake on Ring connector	Figure 13, page 47
Wake on Ring and Resume on Ring technologies	<i>BI440ZX Motherboard Technical Product Specification</i> available through: http://support.intel.com/support/motherboards/desktop

Wake on LAN[†] Technology

Wake on LAN technology enables remote wakeup of the computer through a network. Wake on LAN technology requires a PCI add-in network interface card (NIC) with remote wakeup capabilities. The remote wakeup connector on the NIC must be connected to the onboard Wake on LAN technology connector.

For information about	Refer to
The location of the Wake on LAN technology connector	Figure 13, page 47
Wake on LAN technology	<i>BI440ZX Motherboard Technical Product Specification</i> available through: http://support.intel.com/support/motherboards/desktop



CAUTION

For Wake on LAN, the 5-V standby line for the power supply must be capable of delivering +5 V ± 5 % at 720 mA. Failure to provide adequate standby current when implementing Wake on LAN, can damage the power supply.

Audio Subsystem (Optional)

The audio subsystem consists of these devices:

- Creative Sound Blaster AudioPCI 64V AC '97 digital controller
- Crystal Semiconductor CS4297 stereo audio codec
- Back panel and onboard audio connectors

For information about	Refer to
The locations of the audio connectors	Chapter 5, beginning on page 45
Audio drivers and utilities	http://support.intel.com/support/motherboards/desktop
The AudioPCI 64V AC '97 digital controller and the CS4297 stereo audio codec	<i>BI440ZX Motherboard Technical Product Specification</i> available through: http://support.intel.com/support/motherboards/desktop

Speaker (Optional)

A 47 Ω inductive speaker is mounted on the motherboard. The speaker provides audible error code (beep code) information during the power-on self test (POST).

For information about	Refer to
The location of the onboard speaker	Figure 1, page 8
BIOS beep codes	Table 24, page 51

2 Installing and Replacing Motherboard Components

This chapter tells you how to:

- Install and remove the motherboard
- Install and remove the processor
- Install and remove memory
- Replace the battery

Before You Begin



CAUTION

Before you install this motherboard in a chassis, see Appendix B for regulatory requirements and precautions.

- Always follow the steps in each procedure in the correct order.
- Set up a log to record information about your computer, such as model, serial numbers, installed options, and configuration information.
- Use an antistatic wrist strap and a conductive foam pad when working on the motherboard.



WARNINGS

The procedures in this chapter assume familiarity with the general terminology associated with personal computers and with the safety practices and regulatory compliance required for using and modifying electronic equipment.

Disconnect the computer from its power source and from any telecommunications links, networks, or modems before performing any of the procedures described in this chapter.

Failure to disconnect power, telecommunications links, networks, or modems before you open the computer or perform any procedures can result in personal injury or equipment damage.

Some circuitry on the motherboard can continue to operate even though the front panel power button is off.



CAUTION

Electrostatic discharge (ESD) can damage components. Perform the procedures described in this chapter only at an ESD workstation. If such a station is not available, you can provide some ESD protection by wearing an antistatic wrist strap and attaching it to a metal part of the computer chassis.

How to Install and Remove the Motherboard

Refer to your chassis manual for instructions on installing and removing the motherboard. The motherboard is secured to the chassis by eight screws. Figure 2 shows the locations of the mounting screw holes.

⇒ NOTES

You will need a Phillips (#2 bit) screwdriver.

Refer to Appendix B for regulatory requirements and installation instructions and precautions.



WARNING

This procedure should be done only by qualified technical personnel. Disconnect the computer from its power source before doing the procedures described here. Failure to disconnect the power before you open the computer can result in personal injury or equipment damage.

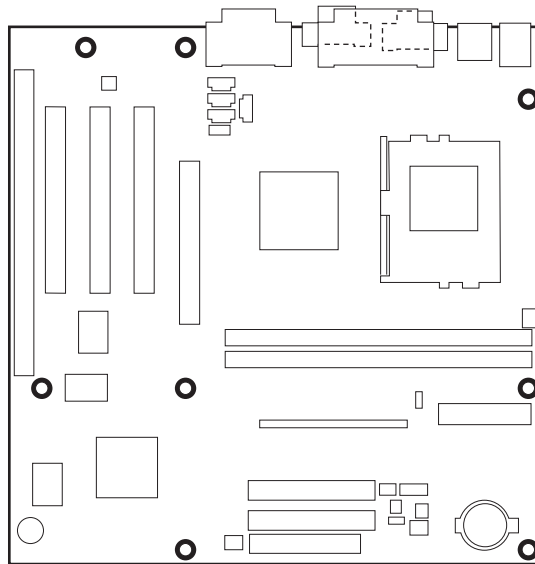

OM07483

Figure 2. Mounting Screw Holes

How to Install a Celeron™ Processor

To install a processor, follow these instructions:

1. Observe the precautions in “Before You Begin” (see page 15).
 2. Raise the socket handle completely (see Figure 3).
-

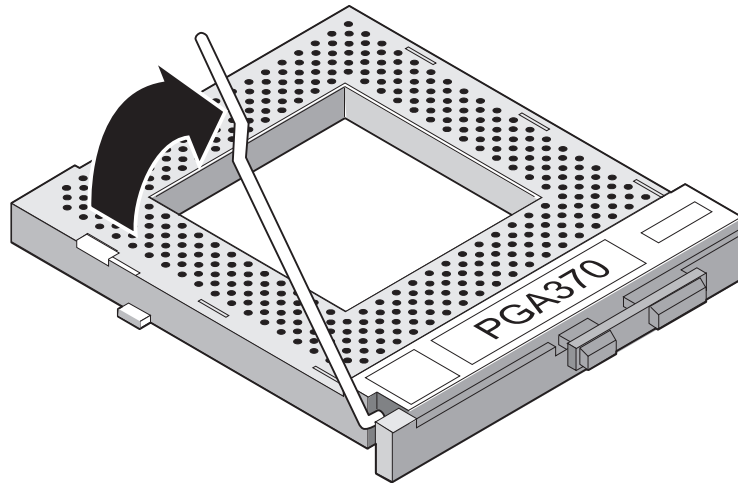

Figure 3. Raising the Socket Handle

3. Aligning the pins of the processor with the socket, insert the processor into the socket (see Figure 4).
-

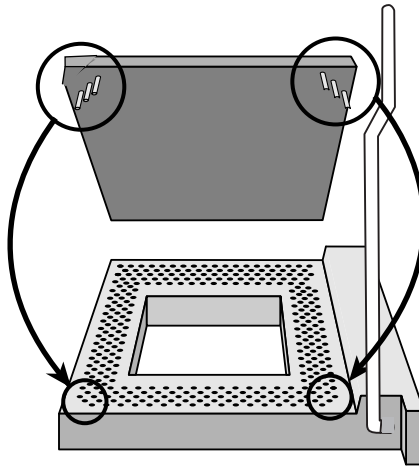

Figure 4. Inserting the Processor Into the Socket

4. Close the handle completely (see Figure 5).

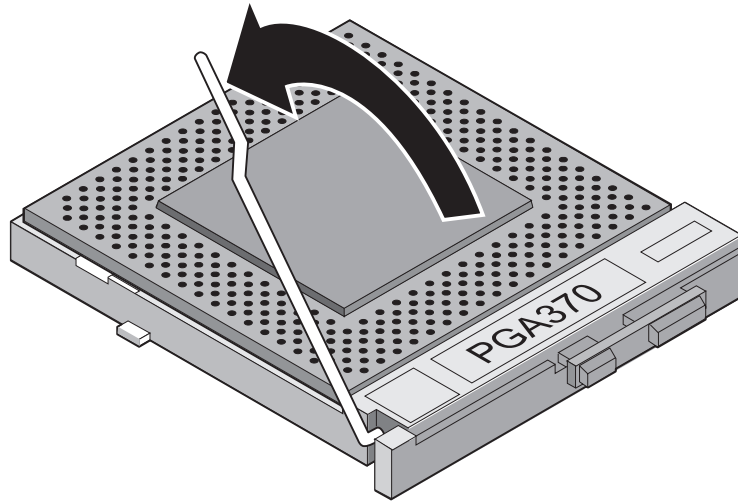

Figure 5. Closing the Handle

5. Peel back the plastic cover from the thermal interface on the bottom of the fan heatsink. Place the fan heatsink on top of the processor (see Figure 6).

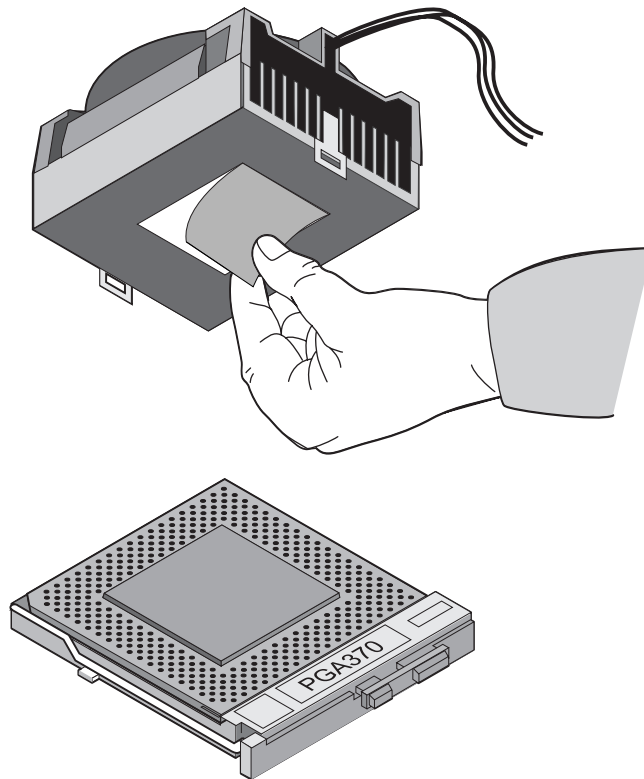

Figure 6. Attaching the Heatsink to the Processor

6. Attach the fan heatsink clip to the processor socket (see Figure 7).

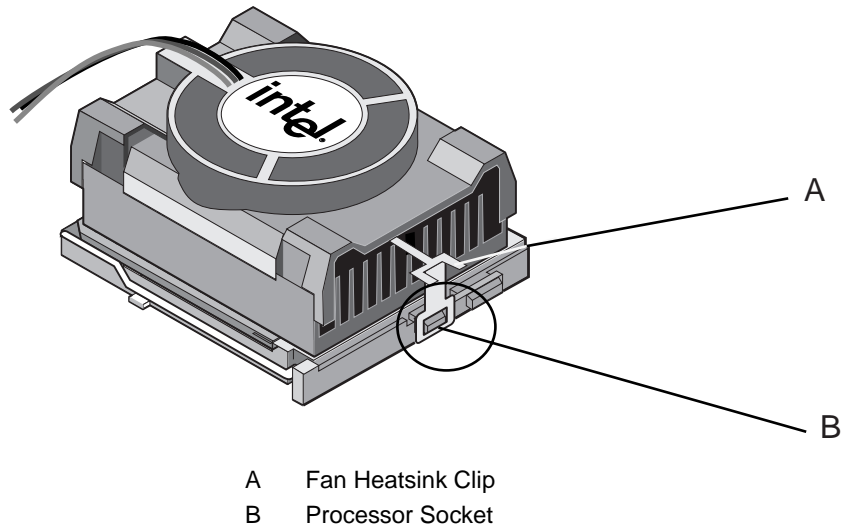

Figure 7. Attaching the Fan Heatsink Clip

7. Connect the processor fan cable to the processor fan connector (see Figure 8).

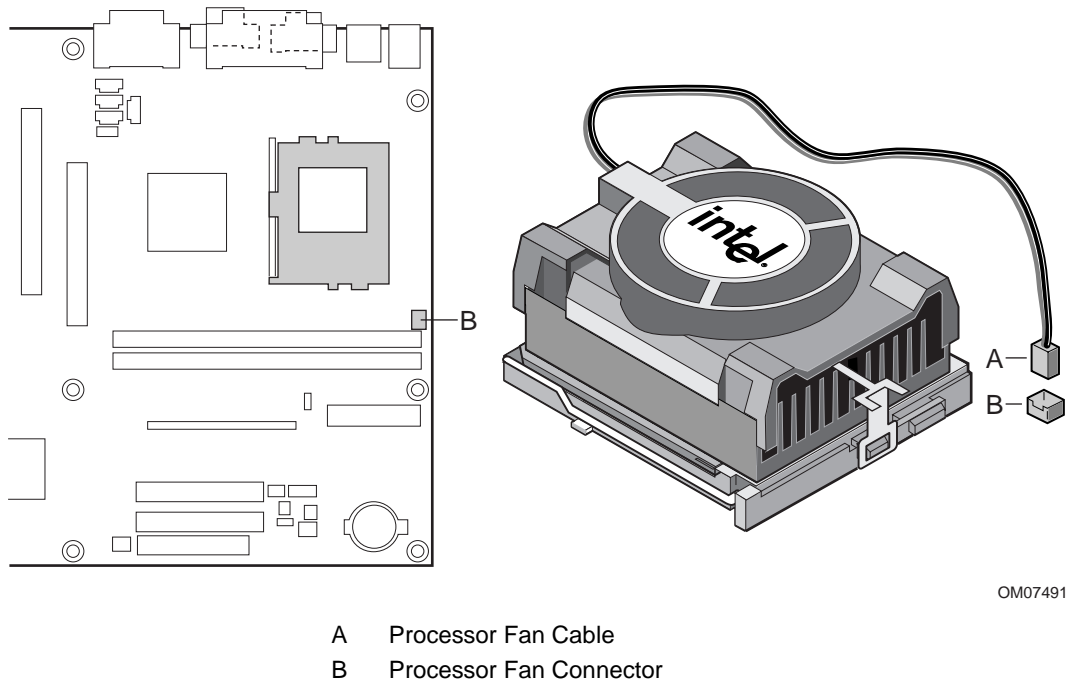

Figure 8. Connecting the Processor Fan Cable to the Processor Fan Connector

How to Remove a Celeron Processor

To remove the processor, follow these instructions:

1. Observe the precautions in “Before You Begin” (see page 15).
2. Disconnect the processor fan cable.
3. Detach the fan heatsink clip.
4. Raise the socket handle completely.
5. Remove the processor.

How to Install Memory

You can install from 16 MB to 256 MB of memory in the DIMM sockets. The board has two DIMM sockets arranged as banks 0 and 1. As shown in Figure 9 on page 21, the DIMM socket closest to the processor is for bank 0.

When adding memory, be aware that:

- You can install DIMMs in either of the two banks. That is, if only one DIMM is being installed, it can be placed in either DIMM socket.
- You can use different sizes of DIMMs in different banks.
- The BIOS detects the size and type of installed memory.

⇒ NOTE

All memory components and DIMMs used with the BI440ZX motherboard must comply with the PC SDRAM Specifications. These include: the PC SDRAM Specification (memory component specific), the PC unbuffered SDRAM Specifications, and the PC Serial Presence Detect Specification. These documents can be accessed through the Internet at:

<http://www.intel.com/design/pcisets/memory>

To install DIMMs, follow these steps:

1. Observe the precautions in “Before You Begin” (see page 15).
2. Turn off all peripheral devices connected to the computer. Turn off the computer.
3. Remove the computer cover and locate the DIMM sockets.
4. Holding the DIMM by the edges, remove it from its antistatic package.
5. Make sure the clips at either end of the socket are pushed away from the socket.
6. Position the DIMM above the socket. Align the two small notches in the bottom edge of the DIMM with the keys in the socket.

7. Insert the bottom edge of the DIMM into the socket (as shown in Figure 9).
8. When the DIMM is seated, push down on the top edge of the DIMM until the retaining clips snap into place. Make sure the clips are firmly in place.
9. Replace the computer cover.

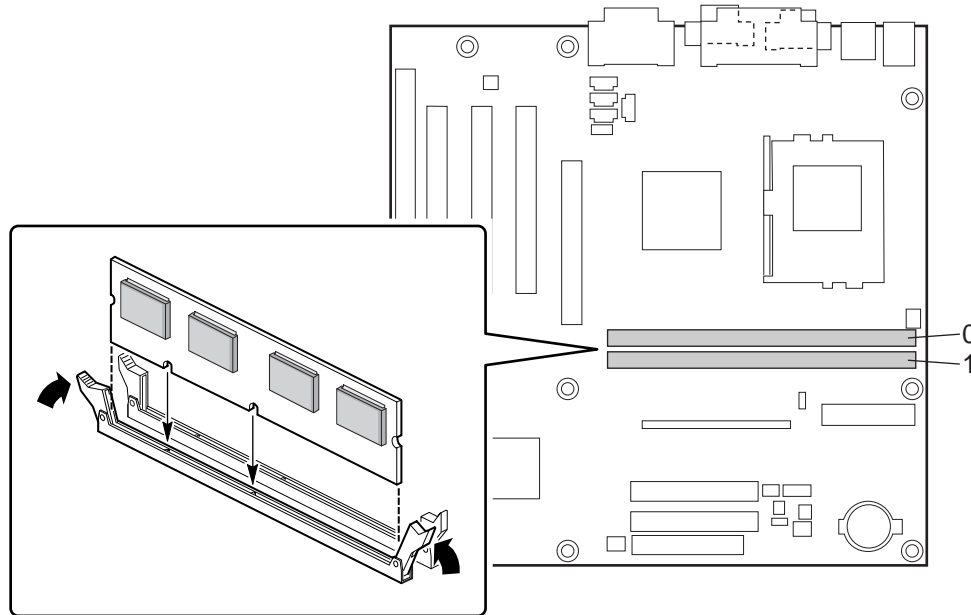

OM07485

Figure 9. Installing a DIMM

How to Remove Memory

To remove a DIMM, follow these steps:

1. Observe the precautions in "Before You Begin" (see page 15).
2. Turn off all peripheral devices connected to the computer. Turn off the computer.
3. Remove the computer cover.
4. Gently spread the retaining clips at each end of the socket. The DIMM pops out of the socket.
5. Hold the DIMM by the edges, lift it away from the socket, and store it in an antistatic package.
6. Reinstall and reconnect any parts you removed or disconnected to reach the DIMM sockets.

How to Replace the Battery

When your computer is turned off, a lithium battery maintains the current time-of-day clock and the values in CMOS RAM current. Figure 10 on page 23 shows the location of the battery.

The battery should last about seven years. When the battery begins to die, it loses voltage; when the voltage drops below a certain level, the BIOS Setup program settings stored in CMOS RAM (for example, the date and time) might not be accurate. Replace the battery with an equivalent one.



WARNING

Danger of explosion if the battery is incorrectly replaced. Replace only with the same or equivalent type recommended by the equipment manufacturer. Discard used batteries according to manufacturer's instructions.



ATTENTION

Il y a danger d'explosion s'il y a remplacement incorrect de la batterie. Remplacer uniquement avec une batterie du même type ou d'un type recommandé par le constructeur. Mettre au rebut les batteries usagées conformément aux instructions du fabricant.



ADVARSEL!

Lithiumbatteri - Eksplosionsfare ved fejlagtig håndtering. Udskiftning må kun ske med batteri af samme fabrikat og type. Levér det brugte batteri tilbage til leverandøren.



ADVARSEL

Lithiumbatteri - Eksplosjonsfare. Ved utskifting benyttes kun batteri som anbefalt av apparatfabrikanten. Brukt batteri returneres apparatleverandøren.



VARNING

Explosionsfara vid felaktigt batteribyte. Använd samma batterityp eller en ekvivalent typ som rekommenderas av apparattillverkaren. Kassera använt batteri enligt fabrikantens instruktion.



VAROITUS

Paristo voi räjähtää, jos se on virheellisesti asennettu. Vaihda paristo ainoastaan laitevalmistajan suosittelemaan tyyppiin. Hävitä käytetty paristo valmistajan ohjeiden mukaisesti.

To replace the battery, follow these steps:

1. Observe the precautions in “Before You Begin” (see page 15).
2. Turn off all peripheral devices connected to the computer. Turn off the computer.
3. Remove the computer cover.
4. Locate the battery on the motherboard (see Figure 10).
5. With a medium flat-bladed screwdriver, gently pry the battery free from its socket. Note the orientation of the “+” and “-” on the battery.
6. Install the new battery in the socket, orienting the “+” and “-” correctly.
7. Replace the computer cover.

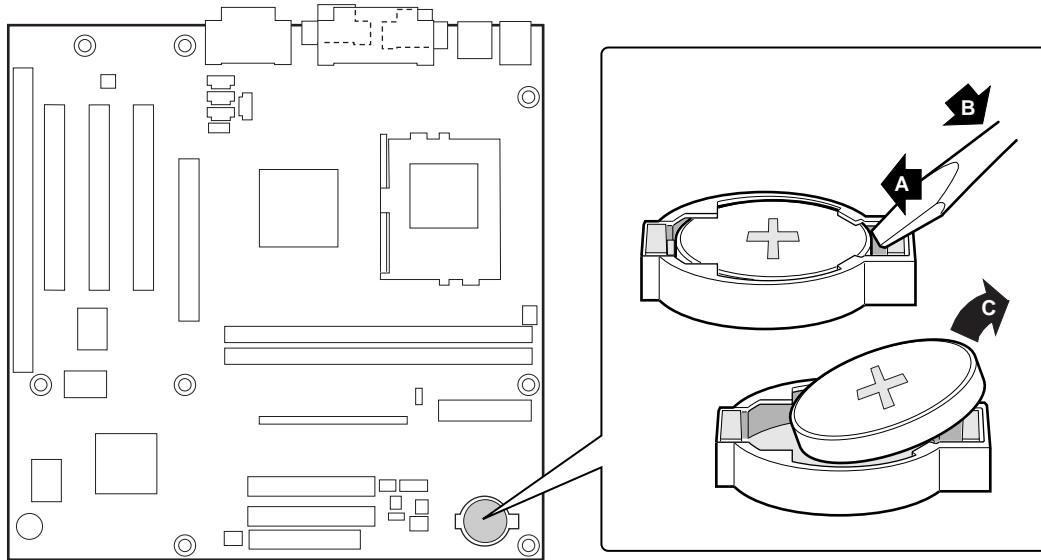

OM07484

Figure 10. Removing the Battery

⇒ **NOTE**

If your local ordinances permit, you may dispose of individual batteries as normal trash. Do not expose batteries to excessive heat or fire. Keep all batteries away from children.

3 Using the BIOS Setup Program

You can use the BIOS Setup program to change the configuration information and boot sequence for the computer. This chapter tells you how to:

- Access the BIOS Setup program
- Upgrade the BIOS
- Recover the BIOS
- Change the BIOS language
- Clear passwords

For information about	Refer to
The contents of the BIOS Setup Program screens	Chapter 4, beginning on page 33
The BIOS Setup program's menus, options, and defaults settings	<i>BI440ZX Motherboard Technical Product Specification</i> available through: http://support.intel.com/support/motherboards/desktop

⇒ NOTE

For reference purposes, you should write down the current Setup settings. When you make changes to the settings, update this record.

BIOS Setup Program Modes



The BIOS Setup program has three modes of operation:

- Normal mode for normal operations
- Configure mode for clearing passwords (page 31 tells how to clear passwords)
- Recovery mode for recovering the BIOS data

The BIOS Setup program operating mode is controlled by the setting of the configuration jumper block J7H1 (see Figure 15 on page 49). The jumper is set to normal mode at the factory.

Table 3 shows jumper settings for the different Setup modes.

Table 3. Jumper Settings for BIOS Setup Program Modes

Function / Mode	Jumper Setting	Configuration
Normal	1-2 J7H1 	The BIOS uses current configuration information and passwords for booting.
Configure	2-3 J7H1 	After the POST runs, Setup runs automatically. The maintenance menu is displayed.
Recovery	none J7H1 	The BIOS attempts to recover the BIOS configuration. A recovery diskette is required.

⇒ NOTE

The Setup menus described in this section apply to BI440ZX motherboards with BIOS identifier 4B4IZOXA.86A. Motherboards with other BIOS identifiers might have differences in some of the Setup menu screens.

Table 4 is an overview of the menu screens in the BIOS Setup program.

Table 4. Setup Menu Bar

Setup Menu Screen	Description
Maintenance	Clears the Setup passwords. This menu is only available in configure mode.
Main	Allocates resources for hardware components.
Advanced	Specifies advanced features available through the chipset.
Security	Specifies passwords and security features.
Power	Specifies power management features.
Boot	Specifies boot options and power supply controls.
Exit	Saves or discards changes to the BIOS Setup program options.

Function Keys

Table 5 shows the function keys available for menu screens.

Table 5. Setup Function Keys

Setup Key	Description
<F1> or <Alt-H>	Brings up a help screen for the current item. Help text appears on the right side of the screen for each selection.
<Esc>	Exits the menu.
<←> or <→>	Selects a different menu screen.
<↑> or <↓>	Moves cursor up or down.
<F9>	Load the default configuration values for the current menu.
<F10>	Save the current values and exit Setup.
<Enter>	Executes command or selects the submenu.

How to Access the BIOS Setup Program

To enter the BIOS Setup program, turn the computer on and immediately press <F2> until you see the message:

```
Entering SETUP
```

How To Upgrade the BIOS

Before you upgrade the BIOS, prepare by:

- Obtaining the BIOS upgrade file
- Recording the current BIOS settings
- Creating a bootable diskette
- Creating the BIOS upgrade diskette

Obtaining the BIOS Upgrade File

You can upgrade to a new version of the BIOS by using the BIOS upgrade file. The BIOS upgrade file is a compressed self-extracting archive that contains all the files you need to upgrade the BIOS. The BIOS upgrade file contains:

- New BIOS files
- BIOS recovery files
- Intel® Flash Memory Update Utility

You can obtain the BIOS upgrade file through your computer supplier or from the Intel World Wide Web site:

<http://support.intel.com/support/motherboards/desktop/>

⇒ NOTE

Please review the instructions distributed with the update utility before attempting a BIOS upgrade.

The Intel Flash Memory Update Utility allows you to:

- Upgrade the BIOS in flash memory
- Update the language section of the BIOS

Recording the Current BIOS Settings

1. Boot the computer and immediately press <F2> until you see the message:

Entering SETUP

⇒ NOTE

Do not skip step 2. You will need these settings to configure your computer at the end of the upgrade procedure.

2. Write down the current settings in the BIOS Setup program.

Creating a Bootable Diskette

⇒ NOTE

If your drive A is an LS-120 diskette drive, you must use a 1.44-MB diskette as the bootable BIOS upgrade diskette. The computer is unable to recover a BIOS from an LS-120 diskette.

Create a Bootable Diskette (using a DOS system to create the bootable diskette)

- Place an unformatted diskette in the diskette drive and format the diskette using the /S option.
Example: format a: /s
- Alternatively, place a formatted diskette in the diskette drive and use the "sys" command.
Example: sys a:

Create a Bootable Diskette (using a non-DOS system to create the bootable diskette)

- Double click on the file 'MK_BOOTZ.EXE' (which is located inside the self-extracting BIOS file). This will create a 'README.TXT' file.

Follow the directions in the 'README.TXT' file.

Creating the BIOS Upgrade Diskette

Obtain the BIOS upgrade file as described in “Obtaining the BIOS Upgrade File” and then:

1. Copy the BIOS upgrade file to a temporary directory on your hard disk.
2. From the C:\ prompt, change to the temporary directory.
3. To extract the file, type the name of the BIOS upgrade file, for example:

```
RCBIOS01.exe
```

4. Press <Enter>. The extracted file contains the following files:

```
LICENSE.TXT
BIOINSTR.TXT
BIOS.EXE
MK_BOOTZ.EXE
```

5. Read the LICENSE.TXT file, which contains the software license agreement, and the BIOINSTR.TXT file, which contains the instructions for the BIOS upgrade.
6. Insert the bootable diskette into drive A.
7. To extract the BIOS.EXE file to the diskette, change to the temporary directory that holds the BIOS.EXE file and type:

```
BIOS A:
```

8. Press <Enter>.
9. The diskette now holds the new BIOS files, the Intel Flash Update Utility, and the recovery files.

Performing the BIOS Upgrade

1. Boot the computer with the BIOS upgrade diskette in drive A. Press <Enter> to go to the Main Menu. The flash memory update utility screen appears.
2. Select Update flash memory area from a file. Press <Enter>.
3. Select Update System BIOS. Press <Enter>.
4. Use the arrow keys to select the correct .bio file. Press <Enter>.
5. When the utility asks for confirmation that you want to flash the new BIOS into memory, select Continue with programming. Press <Enter>.
6. When the utility displays the message Reboot Warning, remove the diskette. Press <Enter>.
7. As the computer boots, check the BIOS identifier (version number) to make sure the upgrade was successful. If a logo appears, press <Esc> to view POST messages.
8. To enter the BIOS Setup program, press <F1> when you see the message:
 Press <F1> to Run SETUP
9. For proper operation, load the BIOS Setup program defaults. To load the defaults, press <F9>.
10. To accept the defaults, press <Enter>.
11. In Setup, set the options to the settings you wrote down before beginning the BIOS upgrade.
12. To save the settings, press <F10>.
13. To accept the settings, press <Enter>.
14. Turn off the computer and reboot.

How to Recover the BIOS

It is unlikely that anything will interrupt the BIOS upgrade; however, if an interruption occurs, the BIOS could be damaged. The following steps explain how to recover the BIOS if an upgrade fails. The following procedure uses recovery mode for the BIOS Setup program. See page 25 for more information on Setup modes.

⇒ NOTE

Because of the small amount of code available in the non-erasable boot block area, there is no video support. You will not see anything on the screen during this procedure. Monitor the procedure by listening to the speaker and looking at the diskette drive LED.

1. Turn off the computer, disconnect the computer's power cord, and disconnect all external peripherals.
2. Remove the computer cover and locate the BIOS Setup program configuration jumper (see Figure 15 on page 49).
3. Remove the jumper from all pins as shown below to set recovery mode for Setup.

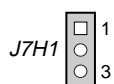

4. Insert the bootable BIOS upgrade diskette into diskette drive A.

5. Replace the computer cover, connect the power cord, turn on the computer, and allow it to boot. The recovery process will take a few minutes.
6. Listen to the speaker.
 - Two beeps and the end of activity in drive A indicate successful BIOS recovery.
 - A series of continuous beeps indicates failed BIOS recovery.
7. If recovery fails, return to step 1 and repeat the recovery process.
8. If recovery is successful, turn off the computer and disconnect its power cord.
9. Remove the computer cover and continue with the following steps.
10. On the jumper block (J7H1), move the jumper back to pins 1-2 as shown below to set normal mode for Setup.

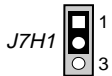

11. Leave the upgrade diskette in drive A, replace the computer cover, and connect the computer's power cord.
12. Turn on the computer and continue with the BIOS upgrade (see page 29).

How to Change the BIOS Language

You can use the BIOS upgrade utility to change the language the BIOS uses for messages and the BIOS Setup program. Use a bootable diskette containing the Intel Flash Memory Update Utility and language files (see “Performing the BIOS Upgrade” on page 29).

1. Boot the computer with the bootable diskette in drive A. The BIOS upgrade utility screen appears.
2. Select `Update Flash Memory From a File`.
3. Select `Update Language Set`. Press `<Enter>`.
4. Select drive A and use the arrow keys to select the correct `.lng` file. Press `<Enter>`.
5. When the utility asks for confirmation that you want to flash the new language into memory, select `Continue with Programming`. Press `<Enter>`.
6. When the utility displays the message `upgrade is complete`, remove the diskette. Press `<Enter>`.
7. The computer will reboot and the changes will take effect.

How to Clear the Passwords

This procedure assumes that the motherboard is installed in the computer and the configuration jumper block is set to normal mode.

1. Observe the precautions in “Before You Begin” (see page 15).
2. Turn off all peripheral devices connected to the computer. Turn off the computer.
3. Remove the computer cover.
4. Find the BIOS Setup program configuration jumper (see Figure 15 on page 49).
5. Place the jumper on pins 2-3 as shown below. This puts the BIOS in configure mode.

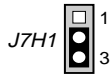

6. Replace the cover, turn on the computer, and allow it to boot.
7. The computer starts the BIOS Setup program. Setup displays the Maintenance menu.
8. Use the arrow keys to select Clear Passwords. Press <Enter> and Setup displays a pop-up screen requesting that you confirm clearing the password. Select Yes and press <Enter>. Setup displays the Maintenance menu again.
9. Press <F10> to save the current values and exit Setup.
10. Turn off the computer.
11. Remove the computer cover.
12. To restore normal operation, place the jumper on pins 1-2 as shown below.



13. Replace the cover and turn on the computer.

4 BIOS Setup Program

The BIOS Setup program is for viewing and changing the BIOS settings for a computer. The BIOS Setup program is accessed by pressing the <F2> key after the Power-On Self Test (POST) memory test begins and before the operating system boot begins. This chapter describes the contents of the BIOS Setup Program's screens.

⇒ NOTE

The Setup screens described in this section apply to BI440ZX motherboards with BIOS identifier 4B4IZOXA.86A. Motherboards with other BIOS identifiers might have differences in some of the Setup screens.

Table 6 shows the menus available from the menu bar at the top of the BIOS Setup program screen.

Table 6. BIOS Setup Program Menu Bar

BISO Setup Program Menu Screen	Description
Maintenance	Used for clearing the BIOS Setup program passwords. This menu is only available in configure mode.
Main	Allocates resources for hardware components.
Advanced	Specifies advanced features available through the chipset.
Security	Specifies passwords and security features.
Power	Specifies power management features.
Boot	Specifies boot options and power supply controls.
Exit	Saves or discards changes to the BIOS Setup program options.

Maintenance Menu

This menu is for clearing the Setup passwords. Setup only displays this menu in configure mode. See page 25 for information about setting configure mode.

Table 7. Maintenance Menu

Feature	Options	Description
Clear All Passwords	No options	Clears the user and administrative passwords

Main Menu

This menu reports processor and memory information and is for configuring the system date and system time.

Table 8. Main Menu

Feature	Options	Description
BIOS Version	No options	Displays the version of the BIOS.
Processor Type	No options	Displays processor type.
Processor Speed	No options	Displays processor speed.
Cache RAM	No options	Displays the size of second-level cache.
Total Memory	No options	Displays the total amount of RAM on the motherboard.
Bank 0 Bank 1	No options	Displays size and type of DIMM installed in each memory bank.
Language	<ul style="list-style-type: none"> • English (US) (default) • German • French • Italian • Spanish 	Selects the default language used by the BIOS.
Cache Bus ECC	[N/A]	Cache bus ECC is not supported.
Memory Configuration	[Non-ECC]	Not supported. (The Intel 82443ZX PAC does not provide ECC support.)
System Time	Hour, minute, and second	Specifies the current time.
System Date	Month, day, and year	Specifies the current date.

Advanced Menu

This menu is for setting advanced features that are available through the chipset.

Table 9. Advanced Menu

Feature	Options	Description
Boot Setting Configuration	No options	Configures Plug and Play and the Numlock key, and resets configuration data. When selected, displays the Boot Settings Configuration submenu.
Peripheral Configuration	No options	Configures peripheral ports and devices. When selected, displays the Peripheral Configuration submenu.
IDE Configuration	No options	Specifies type of connected IDE device.
Diskette Configuration	No options	When selected, displays the Floppy Options submenu.
Event Log Configuration	No options	Configures Event Logging. When selected, displays the Event Log Configuration submenu.
Video Configuration	No options	Configures video features. When selected, displays the Video Configuration submenu.
Resource Configuration	No options	Configures memory blocks and IRQs for legacy ISA devices. When selected, displays the Resource Configuration submenu.

Boot Setting Configuration Submenu

This menu is for setting Plug and Play and the Numlock key, and for resetting configuration data.

Table 10. Boot Setting Configuration Submenu

Feature	Options	Description
Plug & Play O/S	<ul style="list-style-type: none"> • No (default) • Yes 	Specifies if a Plug and Play operating system is being used. <i>No</i> lets the BIOS configure all devices. <i>Yes</i> lets the operating system configure Plug and Play devices. Not required with a Plug and Play operating system.
Reset Config Data	<ul style="list-style-type: none"> • No (default) • Yes 	Clears the BIOS configuration data on the next boot.
Numlock	<ul style="list-style-type: none"> • Off • On (default) 	Specifies the power on state of the Numlock feature on the numeric keypad of the keyboard.

Peripheral Configuration Submenu

This submenu is used for configuring the computer peripherals.

Table 11. Peripheral Configuration Submenu

Feature	Options	Description
Serial port A	<ul style="list-style-type: none"> • Disabled • Enabled • Auto (default) 	<p>Configures serial port A.</p> <p><i>Auto</i> assigns the first free COM port, normally COM1, the address 3F8h, and the interrupt IRQ4.</p> <p>An * (asterisk) displayed next to an address indicates a conflict with another device.</p>
Base I/O address	<ul style="list-style-type: none"> • 3F8 (default) • 2F8 • 3E8 • 2E8 	<p>Specifies the base I/O address for serial port A, if serial port A is Enabled.</p>
Interrupt	<ul style="list-style-type: none"> • IRQ 3 • IRQ 4 (default) 	<p>Specifies the interrupt for serial port A, if serial port A is Enabled.</p>
Serial port B	<ul style="list-style-type: none"> • Disabled • Enabled • Auto (default) 	<p>Configures serial port B.</p> <p><i>Auto</i> assigns the first free COM port, normally COM2, the address 2F8h and the interrupt IRQ3.</p> <p>An * (asterisk) displayed next to an address indicates a conflict with another device.</p> <p>If either serial port address is set, that address will not appear in the list of options for the other serial port.</p>
Mode	<ul style="list-style-type: none"> • Normal (default) • IrDA† SIR-A • ASK_IR 	<p>Specifies the mode for serial port B for normal (COM 2) or infrared applications. This option is not available if serial port B has been disabled.</p>
Base I/O address	<ul style="list-style-type: none"> • 3F8 • 2F8 (default) • 3E8 • 2E8 	<p>Specifies the base I/O address for serial port B.</p>
Interrupt	<ul style="list-style-type: none"> • IRQ 3 (default) • IRQ 4 	<p>Specifies the interrupt for serial port B.</p>

continued

Table 11. Peripheral Configuration Submenu (continued)

Feature	Options	Description
Parallel port	<ul style="list-style-type: none"> • Disabled • Enabled • Auto (default) 	<p>Configures the parallel port.</p> <p><i>Auto</i> assigns LPT1 the address 378h and the interrupt IRQ7.</p> <p>An * (asterisk) displayed next to an address indicates a conflict with another device.</p>
Mode	<ul style="list-style-type: none"> • Output Only • Bi-directional (default) • EPP • ECP 	<p>Selects the mode for the parallel port. Not available if the parallel port is disabled.</p> <p><i>Output Only</i> operates in AT[†]-compatible mode.</p> <p><i>Bi-directional</i> operates in PS/2-compatible mode.</p> <p><i>EPP</i> is Extended Parallel Port mode, a high-speed bi-directional mode.</p> <p><i>ECP</i> is Enhanced Capabilities Port mode, a high-speed bi-directional mode.</p>
Base I/O address	<ul style="list-style-type: none"> • 378 (default) • 278 • 228 	Specifies the base I/O address for the parallel port.
Interrupt	<ul style="list-style-type: none"> • IRQ 5 (default) • IRQ 7 	Specifies the interrupt for the parallel port.
Audio Device	<ul style="list-style-type: none"> • Disabled • Enabled (default) 	Enables or disables the onboard audio subsystem.
Legacy USB Support	<ul style="list-style-type: none"> • Disabled • Enabled • Auto (default) 	Enables or disables USB legacy support.

IDE Configuration

Table 12. IDE Device Configuration

Feature	Options	Description
IDE Controller	<ul style="list-style-type: none"> • Disabled • Primary • Secondary • Both (default) 	Specifies the integrated IDE controller. <i>Primary</i> enables only the Primary IDE Controller. <i>Secondary</i> enables only the Secondary IDE Controller. <i>Both</i> enables both IDE controllers.
Hard Disk Pre-Delay	<ul style="list-style-type: none"> • Disabled (default) • 3 Seconds • 6 Seconds • 9 Seconds • 12 Seconds • 15 Seconds • 21 Seconds • 30 Seconds 	Specifies the hard disk drive pre-delay.
Primary IDE Master	No options	Reports type of connected IDE device. When selected, displays the Primary IDE Master submenu.
Primary IDE Slave	No options	Reports type of connected IDE device. When selected, displays the Primary IDE Slave submenu.
Secondary IDE Master	No options	Reports type of connected IDE device. When selected, displays the Secondary IDE Master submenu.
Secondary IDE Slave	No options	Reports type of connected IDE device. When selected, displays the Secondary IDE Slave submenu.

IDE Configuration Submenus

This submenu is for configuring IDE devices, including:

- Primary IDE master
- Primary IDE slave
- Secondary IDE master
- Secondary IDE slave

Table 13. IDE Configuration Submenus

Feature	Options	Description
Type	<ul style="list-style-type: none"> • None • User • Auto (default) • CD-ROM • ATAPI Removable • Other ATAPI • IDE Removable 	<p>Specifies the IDE configuration mode for IDE devices.</p> <p><i>User</i> allows the cylinders, heads, and sectors fields to be changed.</p> <p><i>Auto</i> automatically fills in the values for the cylinders, heads, and sectors fields.</p>
Maximum Capacity	No options	Reports the maximum capacity for the hard disk, if the type is User or Auto.
LBA Mode Control	<ul style="list-style-type: none"> • Disabled • Enabled (default) 	Enables or disables the LBA mode control.
Multi-Sector Transfers	<ul style="list-style-type: none"> • Disabled • 2 Sectors (default) • 4 Sectors • 8 Sectors • 16 Sectors 	<p>Specifies number of sectors per block for transfers from the hard disk drive to memory.</p> <p>Check the hard disk drive's specifications for optimum setting.</p>
Transfer Mode	<ul style="list-style-type: none"> • Standard • Fast PIO 1 (default) • Fast PIO 2 • Fast PIO 3 • Fast PIO 4 • FPIO 3 / DMA 1 • FPIO 4 / DMA 2 	Specifies the method for moving data to/from the drive.
Ultra DMA	<ul style="list-style-type: none"> • Disabled (default) • Mode 0 • Mode 1 • Mode 2 	Specifies the Ultra DMA mode for the drive.

Diskette Configurations Submenu

This submenu is for configuring the diskette drive.

Table 14. Diskette Configurations Submenu

Feature	Options	Description
Diskette Controller	<ul style="list-style-type: none"> Disabled Enabled (default) 	Disables or enables the integrated diskette controller.
Diskette A:	<ul style="list-style-type: none"> Not Installed 360 KB, 5¼" 1.2 MB, 5¼" 720 KB, 3½" 1.44/1.25 MB, 3½" (default) 2.88 MB, 3½" 	Specifies the capacity and physical size of diskette drive A.
Diskette Write Protect	<ul style="list-style-type: none"> Disabled (default) Enabled 	Disables or enables write protect for the diskette drive.

Event Log Configuration

This submenu is for configuring the event logging features.

Table 15. Event Log Configuration Submenu

Feature	Options	Description
Event log	No options	Indicates if there is space available in the event log.
Event log validity	No options	Indicates if the contents of the event log are valid.
View event log	[Enter]	Displays the event log.
Clear all event logs	<ul style="list-style-type: none"> No (default) Yes 	Clears the event log after rebooting.
Event Logging	<ul style="list-style-type: none"> Disabled Enabled (default) 	Enables logging of Events.
ECC Event Logging	<ul style="list-style-type: none"> Disabled Enabled (default) 	Enables logging of ECC events.
Mark events as read	[Enter]	Marks all events as read.

Video Configuration Submenu

This submenu is for configuring video features.

Table 16. Video Configuration Submenu

Feature	Options	Description
Palette Snooping	<ul style="list-style-type: none"> • Disabled (default) • Enabled 	Controls the ability of a primary PCI graphics controller to share a common palette with an ISA add-in video card.
AGP Aperture Size	<ul style="list-style-type: none"> • 64 MB (default) • 256 MB 	Specifies the aperture size for the AGP video controller.

Resource Configuration Submenu

This submenu is for configuring the memory and interrupts.

Table 17. Resource Configuration Submenu

Feature	Options	Description
Memory Reservation	<ul style="list-style-type: none"> • C8000 – CBFFF Available (default) Reserved • CC000- CFFFF Available (default) Reserved • D0000 - D3FFF Available (default) Reserved • D4000 - D7FFF Available (default) Reserved • D8000 – DBFFF Available (default) Reserved • DC000 – DFFFF Available (default) Reserved 	Reserves specific upper memory blocks for use by legacy ISA devices.
IRQ Reservation	<ul style="list-style-type: none"> • IRQ3 Available (default) Reserved • IRQ4 Available (default) Reserved • IRQ5 Available (default) Reserved • IRQ7 Available (default) Reserved • IRQ10 Available (default) Reserved • IRQ11 Available (default) Reserved 	Reserves specific IRQs for use by legacy ISA devices. An * (asterisk) displayed next to an IRQ indicates an IRQ conflict.

Security Menu

This menu is for setting passwords and security features.

Table 18. Security Menu

Feature	Options	Description
User Password Is	No options	Reports if there is a user password set.
Supervisor Password Is	No options	Reports if there is a supervisor password set.
Set User Password	Password can be up to seven alphanumeric characters.	Specifies the user password.
Set Supervisor Password	Password can be up to seven alphanumeric characters.	Specifies the supervisor password.

Power Menu

This menu is for setting power management features.

Table 19. Power Menu

Feature	Options	Description
Power Management	<ul style="list-style-type: none"> • Disabled • Enabled (default) 	Enables or disables the BIOS power management feature.
Inactivity Timer	<ul style="list-style-type: none"> • Off • 1 Minute • 5 Minutes • 10 Minutes • 20 Minutes (default) • 30 Minutes • 60 Minutes • 120 Minutes 	Specifies the amount of time before the computer enters standby mode.
Hard Drive	<ul style="list-style-type: none"> • Disabled • Enabled (default) 	Enables power management for hard disks during standby and suspend modes.
Video Power Down	<ul style="list-style-type: none"> • Disabled • Standby • Suspend (default) • Sleep 	Specifies power management for video during standby and suspend modes.

Boot Menu

This menu is for setting the boot features and the boot sequence.

Table 20. Boot Menu

Feature	Options	Description
Quiet Boot	<ul style="list-style-type: none"> Disabled Enabled (default) 	<p><i>Disabled</i> displays normal POST messages.</p> <p><i>Enabled</i> displays OEM logo instead of POST messages.</p>
Quick Boot	<ul style="list-style-type: none"> Disabled Enabled (default) 	Enables the computer to boot without running certain POST tests.
Scan User Flash Area	<ul style="list-style-type: none"> Disabled (default) Enabled 	Enables the BIOS to scan the flash memory for user binary files that are executed at boot time.
After Power Failure	<ul style="list-style-type: none"> Stays Off Last State (default) Power On 	<p>Specifies the mode of operation if an AC/Power loss occurs.</p> <p><i>Power On</i> restores power to the computer.</p> <p><i>Stay Off</i> keeps the power off until the power button is pressed.</p> <p><i>Last State</i> restores the previous power state before power loss occurred.</p>
On Modem Ring	<ul style="list-style-type: none"> Stay Off (default) Power On 	Specifies how the computer responds to an incoming call on an installed modem when the power is off.
On LAN	<ul style="list-style-type: none"> Stay Off Power On (default) 	Specifies how the computer responds to a LAN wakeup event when the power is off.
On PME	<ul style="list-style-type: none"> Stay Off (default) Power On 	Specifies how the computer responds to a PME wakeup event when the power is off.
First Boot Device Second Boot Device Third Boot Device Fourth Boot Device	<ul style="list-style-type: none"> Disabled 1st IDE-HDD (Note 1) 2nd IDE-HDD 3rd IDE-HDD 4th IDE-HDD Floppy ARMD-FDD (Note 2) ARMD-HDD (Note 3) ATAPI CDROM SCSI Network I2O 	<p>Specifies the boot sequence from the available devices. To specify boot sequence:</p> <ol style="list-style-type: none"> Select the boot device with <↑> or <↓>. Press <Enter> to set the selection as the intended boot device. <p>The operating system assigns a drive letter to each boot device in the order listed. Changing the order of the devices changes the drive lettering.</p> <p>Not all of the devices in this list are available as second, third, and fourth boot devices. The default settings for the first through fourth boot devices are, respectively:</p> <ul style="list-style-type: none"> Floppy 1st IDE-HDD ATAPI CDROM Disabled

Notes:

- HDD = Hard Disk Drive
- ARMD-FDD = ATAPI removable device - floppy disk drive
- ARMD-HDD = ATAPI removable device - hard disk drive

Exit Menu

This menu is for exiting the BIOS Setup program, saving changes, and loading and saving defaults.

Table 21. Exit Menu

Feature	Description
Exit Saving Changes	Exits and saves the changes in CMOS SRAM.
Exit Discarding Changes	Exits without saving any changes made in the BIOS Setup program.
Load Setup Defaults	Loads the factory default values for all the Setup options.
Load Custom Defaults	Loads the custom defaults for Setup options.
Save Custom Defaults	Saves the current values as custom defaults. Normally, the BIOS reads the Setup values from flash memory. If this memory is corrupted, the BIOS reads the custom defaults. If no custom defaults are set, the BIOS reads the factory defaults.
Discard Changes	Discards changes without exiting Setup. The option values present when the computer was turned on are used.

5 Technical Reference

Motherboard Connectors

The motherboard's connectors can be divided into three groups, as shown in Figure 11.

For information about

Pin descriptions of the motherboard connectors

Refer to

BI440ZX Motherboard Technical Product Specification
available through:
<http://support.intel.com/support/motherboards/desktop>

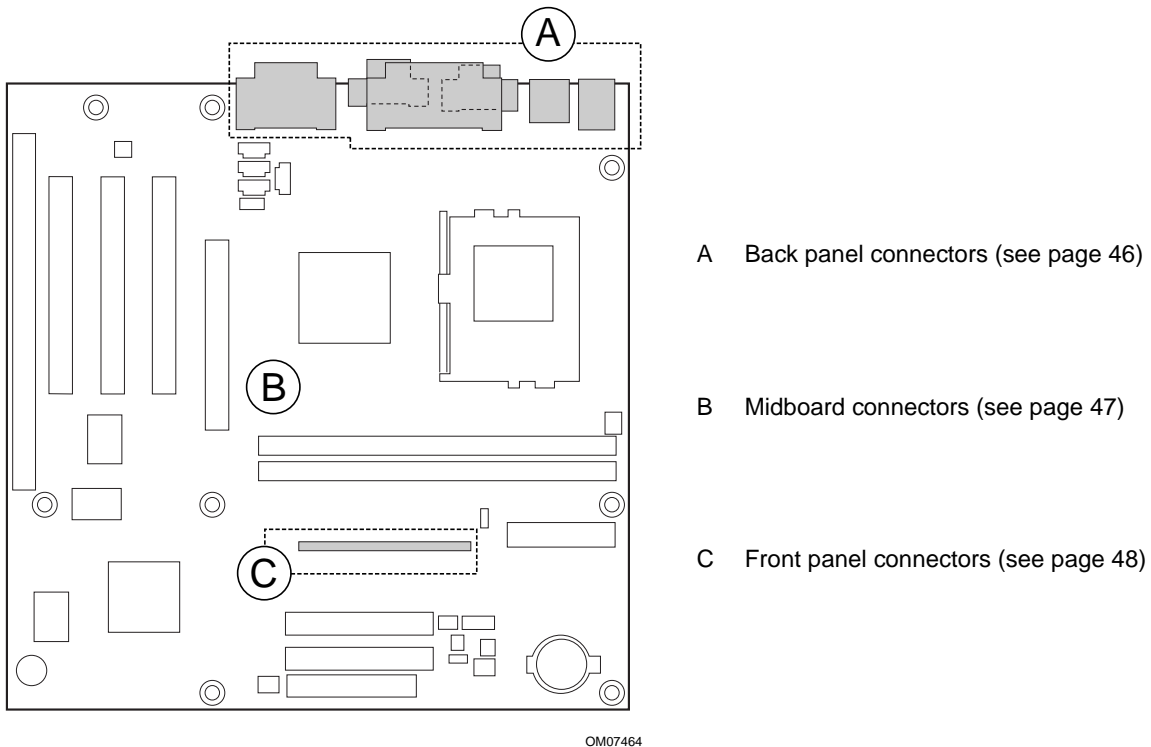

Figure 11. Connector Groups



CAUTION

Many of the midboard and front panel connectors provide operating voltage (+5 V DC and +12 V DC, for example) to devices inside the computer chassis, such as fans and internal peripherals. These connectors are not overcurrent protected. Do not use these connectors for powering devices external to the computer chassis. A fault in the load presented by the external devices could cause damage to the computer, the interconnecting cable, and the external devices themselves.

Back Panel Connectors

Figure 12 shows the back panel connectors on the motherboard.

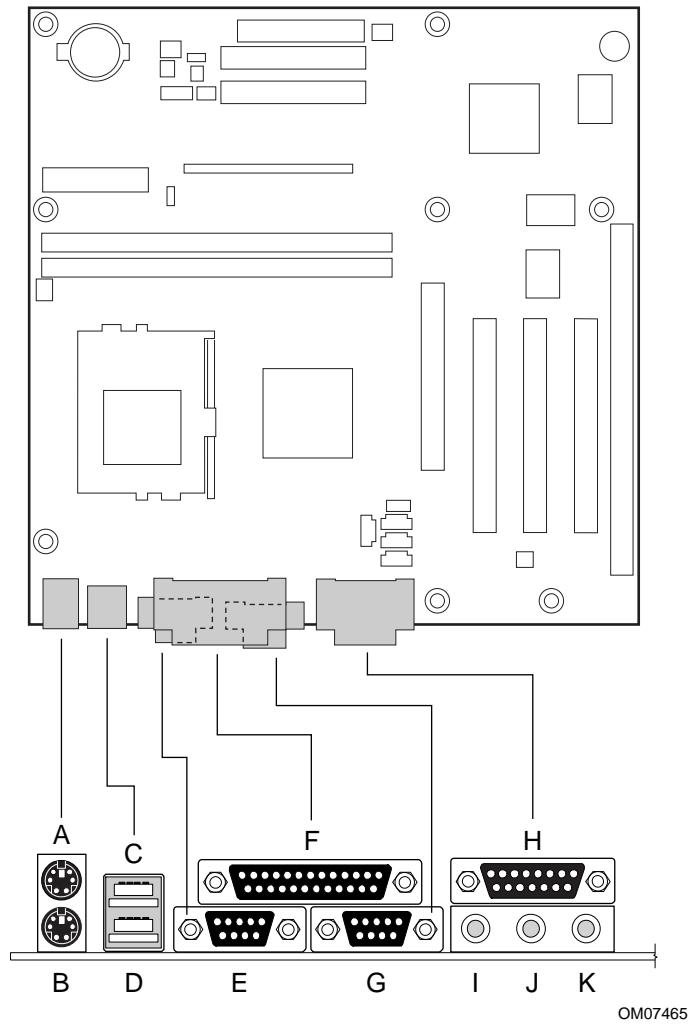

A	PS/2 [†] keyboard or mouse	G	Serial port B
B	PS/2 keyboard or mouse	H	MIDI/Game port
C	USB port 0	I	Audio line out
D	USB port 1	J	Audio line in
E	Serial port A	K	Mic in
F	Parallel port		

Figure 12. Back Panel Connectors

⇒ NOTE

The Line out connector, located on the back panel, is designed to power headphones or amplified speakers only. Poor audio quality may occur if passive (non-amplified) speakers are connected to this output.

Midboard Connectors

Figure 13 shows the locations of the midboard connectors.

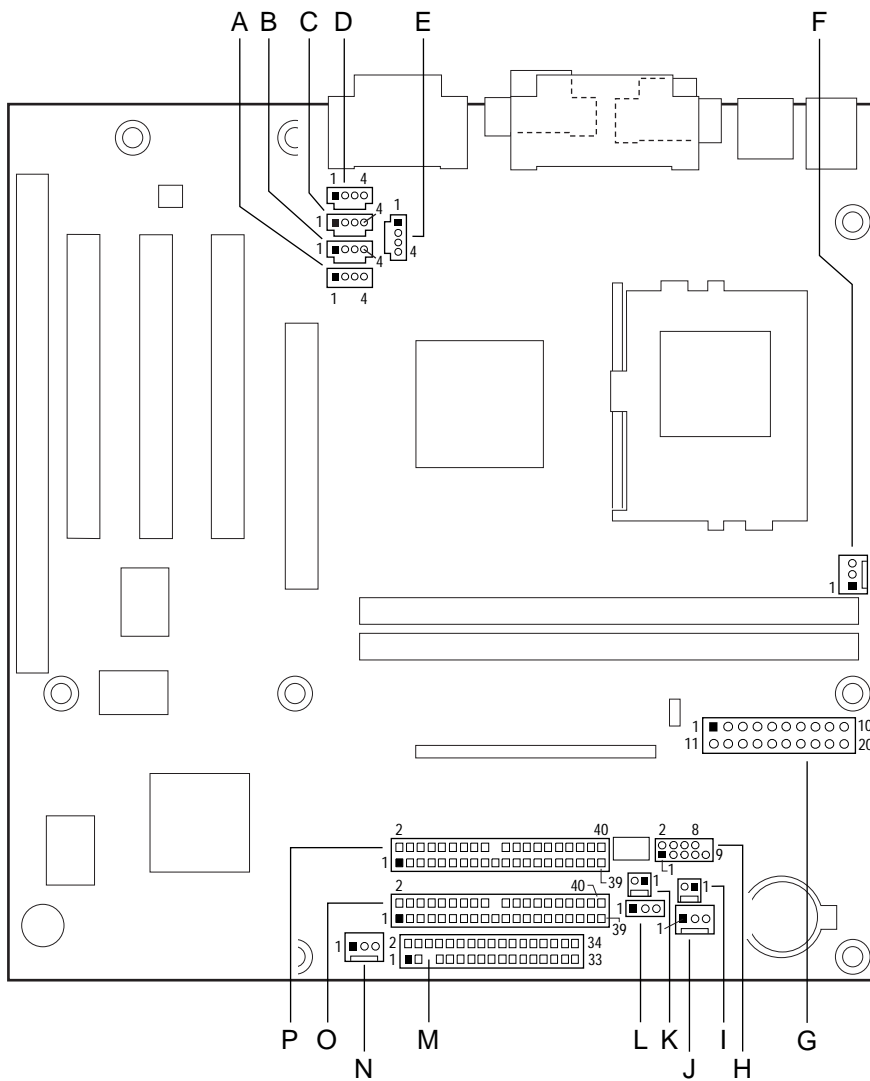

OM07481

- | | | | |
|---|---------------------------------------|---|-------------------------------------|
| A | CD-ROM, legacy style, 2 mm (optional) | I | Wake on Ring (optional) |
| B | Video source line-in, blue (optional) | J | Power supply fan control (optional) |
| C | Auxiliary line in, natural (optional) | K | SCSI LED (optional) |
| D | Telephony, green (optional) | L | Wake on LAN technology |
| E | ATAPI CD-ROM, black (optional) | M | Diskette drive |
| F | Processor fan | N | System fan (optional) |
| G | Power | O | Primary IDE |
| H | USB Front Panel (optional) | P | Secondary IDE |

Figure 13. Midboard Connectors

Front Panel Connector

Figure 14 shows the location of the front panel connector.

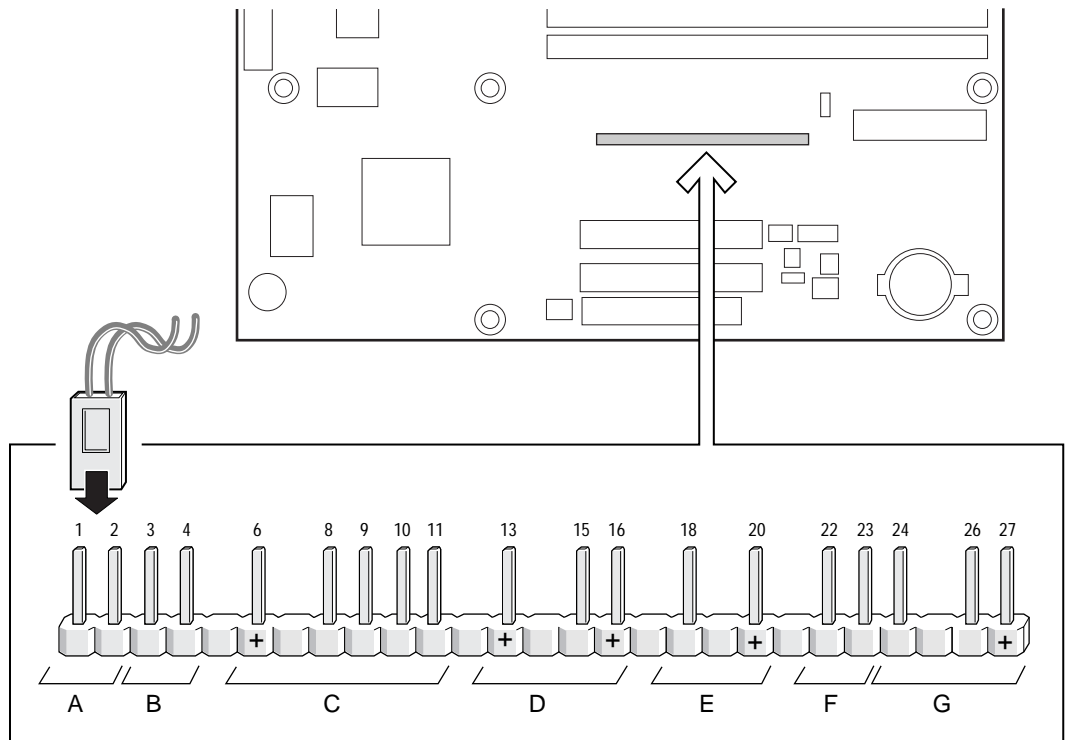

OM07470

- A Power switch
- B Sleep/Resume switch
- C Infrared port
- D Hard drive activity LED
- E Power LED
- F Reset switch
- G Offboard speaker

Figure 14. Front Panel Connector

Jumper Blocks

Figure 15 shows the location of the motherboard's jumper blocks.



CAUTION

Do not move jumpers with the power on. Always turn off the power and unplug the power cord from the computer before changing jumper settings. Otherwise, the board could be damaged.

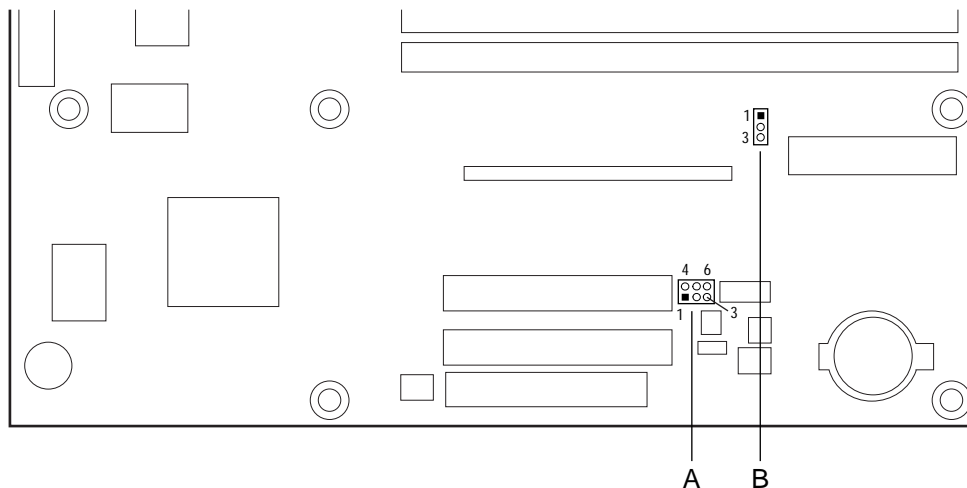

OM07471



- A USB Port 0 configuration jumper block (optional)
- B BIOS setup configuration jumper block

Figure 15. Location of the Jumper Blocks

BIOS Setup Configuration Jumper Block

This 3-pin jumper block enables all motherboard configuration to be done in BIOS Setup. Table 22 describes the jumper settings for normal, configure, and recovery modes.

Table 22. BIOS Setup Configuration Jumper Settings

Function / Mode	Jumper Setting	Configuration
Normal	1-2 <i>J7H1</i> 	The BIOS uses current configuration information and passwords for booting.
Configure	2-3 <i>J7H1</i> 	After the POST runs, Setup runs automatically. The maintenance menu is displayed.
Recovery	none <i>J7H1</i> 	The BIOS attempts to recover the BIOS configuration. A recovery diskette is required.

USB Port 0 Configuration Jumper Block (Optional)

This 6-pin jumper block enables configuration of USB Port 0. Table 23 describes the jumper settings for configuring USB Port 0.

Table 23. USB Port 0 Configuration Jumper Settings

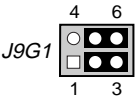
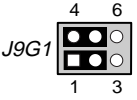
Jumper Setting	Configuration
2-3 and 5-6 	USB Port 0 signals are routed to the back panel
1-2 and 4-5 	USB Port 0 signals are routed for a front panel USB connector

A Error Messages

BIOS Beep Codes

Whenever a recoverable error occurs during power-on self test (POST), the BIOS displays an error message describing the problem. The BIOS also issues a beep code (one long tone followed by two short tones) during POST if the video configuration fails (a faulty video card or no card installed) or if an external ROM module does not properly checksum to zero.

Table 24. Beep Codes

Beep	Description
1	Refresh failure
2	Parity can not be reset
3	First 64 K memory failure
4	Timer not operational
5	Processor failure (Reserved; not used)
6	8042 GateA20 cannot be toggled
7	Exception interrupt error
8	Display memory R/W error
9	ROM checksum error (Reserved; not used)
10	CMOS Shutdown register test error
11	Invalid BIOS (e.g., POST module not found)

BIOS Error Messages

Table 25. BIOS Error Messages

Error Message	Explanation
GA20 Error	An error occurred with Gate-A20 when switching to protected mode during the memory test.
Pri Master HDD Error Pri Slave HDD Error Sec Master HDD Error Sec Slave HDD Error	Could not read sector from corresponding drive.
Pri Master Drive - ATAPI Incompatible Pri Slave Drive - ATAPI Incompatible Sec Master Drive - ATAPI Incompatible Sec Slave Drive - ATAPI Incompatible	Corresponding drive in not an ATAPI device. Run Setup to make sure device is selected correctly.
A: Drive Error B: Drive Error	No response from diskette drive.

continued

Table 25. BIOS Error Messages (continued)

Error Message	Explanation
Cache Memory Bad	An error occurred when testing L2 cache. Cache memory may be bad.
CMOS Battery Low	The battery may be losing power. Replace the battery soon.
CMOS Display Type Wrong	The display type is different than what has been stored in CMOS. Check Setup to make sure type is correct.
CMOS Checksum Bad	The CMOS checksum is incorrect. CMOS memory may have been corrupted. Run Setup to reset values.
CMOS Settings Wrong	CMOS values are not the same as the last boot. These values have either been corrupted or the battery has failed.
CMOS Date/Time Not Set	The time and/or date values stored in CMOS are invalid. Run Setup to set correct values.
DMA Error	Error during read/write test of DMA controller.
FDC Failure	Error occurred trying to access diskette drive controller.
HDC Failure	Error occurred trying to access hard disk controller.
Checking NVRAM.....	NVRAM is being checked to see if it is valid.
Update OK!	NVRAM was invalid and has been updated.
Updated Failed	NVRAM was invalid but was unable to be updated.
Keyboard Is Locked	The system keyboard lock is engaged. The system must be unlocked to continue to boot.
Keyboard Error	Error in the keyboard connection. Make sure keyboard is connected properly.
KB/Interface Error	Keyboard Interface test failed.
Memory Size Decreased	Memory size has decreased since the last boot. If no memory was removed then memory may be bad.
Memory Size Increased	Memory size has increased since the last boot. If no memory was added there may be a problem with the system.
Memory Size Changed	Memory size has changed since the last boot. If no memory was added or removed then memory may be bad.
No Boot Device Available	System did not find a device to boot.
Off Board Parity Error	A parity error occurred on an offboard card. This error is followed by an address.
On Board Parity Error	A parity error occurred in onboard memory. This error is followed by an address.
Parity Error	A parity error occurred in onboard memory at an unknown address.
NVRAM / CMOS / PASSWORD cleared by Jumper	NVRAM, CMOS, and passwords have been cleared. The system should be powered down and the jumper removed.
<CTRL_N> Pressed	CMOS is ignored and NVRAM is cleared. User must enter Setup.

B Regulatory and Integration Information

This appendix contains:

- Safety standards, electromagnetic compatibility regulations, and product certification markings for this motherboard
- Instructions and precautions for integrators who are installing this motherboard in a chassis

Regulatory Compliance

This motherboard complies with the following safety and EMC regulations when correctly installed in a compatible chassis

Table 26. Safety Regulations

Regulation	Title
UL 1950/CSA950, 3 rd edition, Dated 07-28-95	Bi-National Standard for Safety of Information Technology Equipment including Electrical Business Equipment. (USA and Canada)
EN 60950, 2 nd Edition, 1992 (with Amendments 1, 2, 3, and 4)	The Standard for Safety of Information Technology Equipment including Electrical Business Equipment. (European Community)
IEC 950, 2 nd edition, 1991 (with Amendments 1, 2, 3, and 4)	The Standard for Safety of Information Technology Equipment including Electrical Business Equipment. (International)
EMKO-TSE (74-SEC) 207/94	Summary of Nordic deviations to EN 60950. (Norway, Sweden, Denmark, and Finland)

Table 27. EMC Regulations

Regulation	Title
FCC Class B	Title 47 of the Code of Federal Regulations, Parts 2 and 15, Subpart B, pertaining to unintentional radiators. (USA)
CISPR 22, 2 nd Edition, 1993 (Class B)	Limits and methods of measurement of Radio Interference Characteristics of Information Technology Equipment. (International)
VCCI Class B (ITE)	Implementation Regulations for Voluntary Control of Radio Interference by Data Processing Equipment and Electronic Office Machines. (Japan)
EN55022 (1994) (Class B)	Limits and methods of measurement of Radio Interference Characteristics of Information Technology Equipment. (Europe)
EN50082-1 (1992)	Generic Immunity Standard; currently compliance is determined via testing to IEC 801-2, -3, and -4. (Europe)
ICES-003 (1997)	Interference-Causing Equipment Standard, Digital Apparatus, Class B (Including CRC c.1374). (Canada)

This printed circuit assembly has the following product certification markings

- UL Joint Recognition Mark: Consists of small c followed by a stylized backward UR and followed by a small US (Component side)
- Manufacturer's recognition mark: Consists of a unique UL recognized manufacturer's logo, along with a flammability rating (94V-0) (Solder side)
- UL File Number for motherboards: E139761 (Component side)
- PB Part Number: Intel bare circuit board part number (Solder side) 720848-001
- Battery "+ Side Up" marking: Located on the component side of the board in close proximity to the battery holder
- FCC Logo/Declaration: (Solder side)
- CE Mark: (Component side) The CE mark should also be on the shipping container

Installation Precautions

When you install and test the motherboard, observe all warnings and cautions in the installation instructions.

To avoid injury, be careful of:

- Sharp pins on connectors
- Sharp pins on printed circuit assemblies
- Rough edges and sharp corners on the chassis
- Hot components (like processors, voltage regulators, and heat sinks)
- Damage to wires that could cause a short circuit

Observe all warnings and cautions that instruct you to refer computer servicing to qualified technical personnel.



WARNING

Do not open the power supply. Risk of electric shock and burns from high voltage and rapid overheating. Refer servicing of the power supply to qualified technical personnel.

Installation Instructions



CAUTION

Follow these guidelines to meet safety and regulatory requirements when installing this board assembly.

Read and adhere to all of these instructions and the instructions supplied with the chassis and associated modules. If the instructions for the chassis are inconsistent with these instructions or the instructions for associated modules, contact the supplier's technical support to find out how you can ensure that your computer meets safety and regulatory requirements. If you do not follow these instructions and the instructions provided by chassis and module suppliers, you increase safety risk and the possibility of noncompliance with regional laws and regulations.

Ensure Electromagnetic Compatibility (EMC)

Before computer integration, make sure that the power supply and other modules have passed EMC testing using a motherboard with a processor from the same family and operating at the same (or higher) speed as the processor on this motherboard.

In the installation instructions for the host chassis, power supply, and other modules pay close attention to the following:

- Certifications
- External I/O cable shielding and filtering
- Mounting, grounding, and bonding requirements
- Keying connectors when mismating of connectors could be hazardous

If the power supply and other modules have not passed applicable EMC testing before integration, EMC testing must be conducted on a representative sample of the newly completed computer.

Ensure Chassis and Accessory Module Certifications

Make sure that the chassis, any added subassembly, such as a board or drive assembly, and internal or external wiring, are certified for the region(s) where the end-product will be used. Marks on the product are proof of certification. Certification marks are as follows:

In Europe

The CE marking signifies compliance with all relevant European requirements. If the chassis does not bear the CE marking, obtain a supplier's Declaration of Conformity to the appropriate standards required by the European EMC Directive and Low Voltage Directive. Other directives, such as the Machinery and Telecommunications Directives, might also apply depending on the type of product. No regulatory assessment is necessary for low voltage DC wiring used internally or wiring used externally when provided with appropriate overcurrent protection. Appropriate protection is provided by a maximum 8-A current limiting circuit or a maximum 5-A fuse or positive temperature coefficient (PTC) resistor. All Intel motherboards now have PTCs on all external ports that provide DC power externally.

In the United States

A certification mark by a Nationally Recognized Testing Laboratory (NRTL) such as UL, CSA, or ETL signifies compliance with safety requirements. External wiring must be UL Listed and suitable for the intended use. Internal wiring must be UL Listed or Recognized and rated for applicable voltages and temperatures. The FCC mark (Class A for commercial or industrial only or Class B for residential) signifies compliance with electromagnetic interference requirements.

In Canada

A nationally recognized certification mark such as CSA or cUL signifies compliance with safety requirements. No regulatory assessment is necessary for low voltage DC wiring used internally or wiring used externally when provided with appropriate overcurrent protection. Appropriate protection is provided by a maximum 8-A current limiting circuit or a maximum 5-A fuse or positive temperature coefficient (PTC) resistor. All Intel motherboards now have PTCs on all external ports that provide DC power externally.

Prevent Power Supply Overload

Unless the power supply has inherent overcurrent protection, do not overload the power supply output. To avoid overloading the power supply, make sure that the calculated total current load of all the modules within the computer is less than the output current rating of the power supply. If you do not do this, the power supply could overheat, catch fire, or damage the insulation that separates hazardous AC line circuitry from low-voltage user accessible circuitry. If the load drawn by a module cannot be determined by the markings and instructions supplied with the module, contact the module supplier's technical support.

Place Battery Marking on the Computer

There is insufficient space on this motherboard to provide instructions for replacing and disposing of the battery. The following warning must be placed permanently and legibly on the chassis as near as possible to the battery.



WARNINGS

Danger of explosion if battery is incorrectly replaced.

Replace with only the same or equivalent type recommended by the manufacturer. Dispose of used batteries according to the manufacturer's instructions.

Use Only for Intended Applications

This motherboard was evaluated for use in computers that will be installed in offices, homes, schools, computer rooms, and similar locations. The suitability of this product for other applications, (such as medical, industrial, alarm systems, and test equipment) might require further evaluation.