

**6A815EP+**  
**(INTEL i815EP Chipset, S-370)**  
**ATX Form Factor**  
**Main Board**  
User's Manual  
(Ver. 1.0)

## **Copyright**

Copyright©2001 by this company. No part of this document may be reproduced, transmitted, transcribed, stored in a retrievable system, or translated into any natural or computer language, in any form or by any means without prior written permission. This manual and the information contained here are protected by copyright. All rights reserved.

Manual version: 1.0  
Ref. No: 3053338  
Published in 2001

### **Warning and disclaimer**

This manual is designed to provide information about the Pentium® II/III main board. Every has effort have been made to make this manual as accurate as possible, but no warranty or fitness is implied. All the information is provided on an 'as is' basis. The author and his corresponding publishing company shall have neither liability nor responsibility to any person or entity with respect to any loss or damages arising from the information contained in this manual or from the use of the system board that accompanies it.

Information contained in this manual is subject to change without notice. The manufacturer of the system board will not be held responsible for technical or editorial omissions made herein, nor for the incidental or consequential damages resulting from its furnishing, performance, functionality or use. Subsequent changes to this manual will be incorporated into the next edition. We welcome any suggestion regarding this manual or our computer products.

### **Trademarks**

- Intel® and Pentium® are registered trademarks of Intel® Corporation.
- IBM® is a registered trademark of International Business Machines Corporation.
- Microsoft® is a registered trademark of Microsoft® Corporation.
- PCI® is a registered trademark of PCI® Special Interest Groups.
- AWARD® is a registered trademark of Award Software Inc.

All other trademarks are the property of their respective owners.

---

## Table of Contents

■	<b>Chapter 1 Introduction.....</b>	<b>1</b>
1-1	Overview.....	1
1-2	Specifications.....	3
1-3	Notice of Hardware Installation.....	4
1-4	Notice of CD Driver Installation.....	5
1-5	Software Driver Installation.....	6
1-6	Creative Sound Driver Installation .....	7
■	<b>Chapter 2 Installation.....</b>	<b>8</b>
2-1	Layout Reference.....	8
2-2	Jumper Setting.....	9
2-2-1	JP6 : Keyboard Wake Up Selector.....	8
2-2-2	JP8 : Flash ROM (BIOS) Selector.....	10
2-2-3	JP7 :USB Keyboard Wake Up.....	11
2-2-4	S2, JP15, JP17, JP18: CPU & DIMM Clock Select.....	12
2-2-5	JP27: RTC-COMS Status.....	13
2-2-6	S1:CPU Vcore Selector.....	14
2-2-7	JP30: Creative Sound Selection(optional) .....	16
2-3	Connectors .....	17
2-3-1	Front Panel.....	17
2-3-2	Back Panel.....	19
	<i>KBD/PS2 MOUSE</i> .....	20
	<i>USB1/USB2</i> .....	20
	<i>COM1 &amp; COM2</i> .....	20
	<i>LPT</i> .....	20
	<i>Midi/Game Port &amp; External Audio Connectors</i> .....	20
2-3-3	ATX Power Supply Connector.....	21
2-3-4	CPU Fan Connectors.....	22
2-3-5	LR2: IrDA Connector.....	23
2-3-6	JP2/JP3: CD_IN.....	24
2-3-7	Floppy Disk Connector.....	25
2-3-8	IDE1 & IDE2.....	26
2-3-9	WOL1 : Wake up on LAN.....	27
2-3-10	CN11: Smart Card Reader Connector (Optional) .....	28
2-4	DIMM Installation.....	29

---

■	<b>Chapter 3 Phoenix™ BIOS Porting Guide.....</b>	<b>25</b>
3-1	Product Overview.....	25
3-2	Graphical Launch Screen(GLS).....	26
■	<b>Chapter 4 BIOS Setup.....</b>	<b>27</b>
4-1	Award BIOS CMOS Setup.....	27
4-1-1	Standard CMOS Features.....	28
4-1-2	Advanced BIOS Features .....	31
4-1-3	Advanced Chipset Features.....	35
4-1-4	Integrated Peripherals.....	38
4-1-5	Power Management Setup.....	43
4-1-6	PnP/PCI Configuration Setup.....	47
4-1-7	PC Health Status.....	49
4-1-8	Frequency/Voltage Control.....	50
4-1-9	Load Fail-Safe Defaults.....	52
4-1-10	Load Optimized Defaults.....	53
4-1-11	Supervisor/User Password.....	54
4-1-12	Save & Exit Setup.....	57
4-1-13	Quit Without Saving.....	58
■	<b>Chapter 5 Appendix.....</b>	<b>59</b>
5-1	Memory Map.....	59
5-2	I/O Map.....	60
5-3	Time & DMA Channels Map.....	61
5-4	Interrupt Map.....	62
5-5	RTC & CMOS RAM Map.....	63
5-6	Award BIOS Hard Disk Type.....	64
5-7	ISA I/O Address Map.....	66
■	<b>Chapter 6 Q &amp; A.....</b>	<b>68</b>
6-1	Error Messages During Power on Self Test.....	68

---

# Chapter 1 Introduction

## 1-1 Overview

The main board utilizes Intel's latest i815EP chipset integrated with new architects such as high-speed 2X/4X mode AGP interface multiplexed UDMA66/100, CNR (communication Networking Riser) SDRAM, USB port are designed to fit INTEL® PPGA and FC-PGA 66/100MHz Celeron CPUs or FC-PGA 100/133MHz PIII® Coppermine™/CyrixIII CPUs.

The Intel®815EP Chipset is a high-flexibility chipset designed to extend from the basic graphics/multimedia PC platform up to the mainstream performance desktop platform. The chipset consists of a Memory Controller Hub(Intel® 815 MCH), an I/O Controller Hub(ICH) for the I/O subsystem, and a Firmware Hub(FWH). The Intel®815EP MCH integrates a system memory SDRAM controller that supports a 64-bit 100/133 MHz SDRAM array.

The main board also employs ITE I/O LPC controller utilizing with fully Plug and Play device and keyboard password setup. It supports 2.88 MB Floppy, Dual 16550 compatible (with 16 bytes FIFO, up to 460K baud rate) serial Port, ECP (Enhanced Capabilities Port), EPP(Enhanced Parallel Port) parallel port, SPP(Standard Parallel Port), Infrared IrDA (HPSIR), and Amplitude Shift Keyed IR. (ASKIR) port and hardware monitor functions too.

The main board contains 5\*PCI for highest performance I/O add-on adapter cards. It supports Matrix Independent PCI routing for optimal multiple PCI adapter operations and is PCI 2.2 specification compliant. It supports back to back sequential CPU to PCI Memory writes to PCI Burst Write for full PCI throughput. The new CNR Slot is designed to fit C(Communication) N(Networking) R(Riser) or MR card.

---

The main board has 3 dual in-line memory modules (DIMM) which can be installed with PC-100/PC-133 SDRAM memory. The memory subsystem supports up to 512 MB SDRAM of non-buffered 3.3V using standard 168-pin DIMM sockets.

In conclusion, the system chipset and design make the main board a high performance, cost-effective, and energy efficient main board which meets a variety of price/performance levels. The main board is an ideal platform for the increasing requirements of today's and future's desktop applications.



*AC-97, CNR are optional functions.*

---

## 1-2 Specifications

- **PCB Board size** : 30.5cm(L) x 21.0cm(W), ATX form factor, 4 layers PCB.
- **CPU** : Socket370 for Intel® Celeron™/Coppermine™ PIII® or VIA CyrixIII CPU up to 1GHz or faster processor.



*CPU is not enclosed in the package.*

- **Memory** : Supports up to 3 double sided DIMMs at 100MHz system memory bus.  
Supports up to 2 double sided or 3 single sided DIMMs at 133MHz system memory bus.
- **AGP** : support 1X/2X/4X AGP VGA cards.
- **Expansion Slot** : 5 x PCI slots, 1 x AGP, 1 x CNR
- **Other features**
  - Windows 95/98 power off
  - Keyboard wake-up
  - Mouse wake-up
  - DMI, ACPI supported BIOS



*INTEL 815EP chipset only supports up to 2 double sided DIMMs at 133MHz CPU Bus.*



---

## 1-3 Notice of Hardware Installation

Before installing the main board hardware, please note the following things.

### **A. Check the package**

If any of the below items is missing or damaged, contact the dealer from whom you purchase. Leave this main board in its original package until you are ready to install it. In the package, there are:

- the main board
- manual
- cables
- driver & utility / CD

### **B. Make sure power is off.**

During hardware installation, be sure that there is no power connected in this period.

### **C. Avoid ESD (Electrical Static Discharge)**

While working with this main board, always wear a grounded wristband or ankle strap to avoid ESD (Electrical Static Discharge).

---

## 1-4 Notice of CD Driver Installation

This CD contains the following drivers. The user must read “Index” (HTML format) before installing required drivers. Index offers all the information on all the drivers.

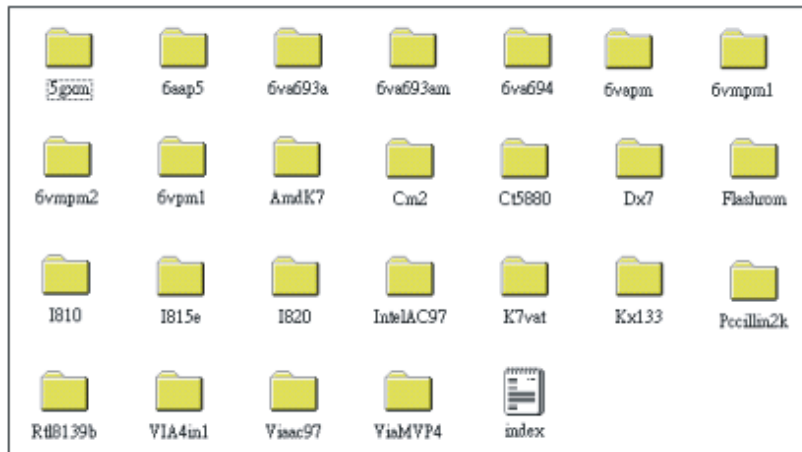

*CD driver is always updated with the latest version, and thus the actual CD content may be different from the above picture.*

1. **Main boards:** 5gxm, 6aap5, 6va693a, 6va693am, 6va694, 6vapm, 6vmpm1, 6vmpm2, 6vpm1, Amdk7, I810, I815e, I820, K7vat, Kx133, ViaMVP4 (please select I815E directory for this main board)
2. **For sound codec drivers (AD1881), please load from i815e directory.**
3. **For Hardware Sound (Optional) CT5880, please load from CT5880 directory.**
4. **DX7:** Windows DirectX7 driver.
5. **Flashrom:** BIOS flash upgrade utility .

---

## 1-5 Software Driver Installation

Unlike i440BX, i815EP chipset is not supported by the drivers within Windows operating system, **USERS NEED TO INSTALL DRIVERS VERY CAREFULLY OR SYSTEM WILL HANG UP UNEXPECTEDLY!**

Load drivers from attached CD & find sub-directories under i815E directory as:

**Inf**.....(Setup driver for i815EP chipset)

Load drivers from attached CD & find sub-directories under i815E directory as:

**AD1881**.....(Drivers for AC-97 Codec Sound function)

User needs to install drivers

**Inf** → **AD1881** as below:

### **FOR WINDOWS OPERATING SYSTEM :**

- (1) Install Inf :  
Load attached CD & find “Inf” directory. Then execute “Setup” file.  
(Window versions are Win98 or higher version).
- (2) Audio Driver Installation (AC-97 Codec Sound driver)  
Find “AD1881” sub-directory, then find Win-98 sub-directory, then find “Win98” execute “SETUP” & restart system.

---

## 1-6 **Install Creative Sound Driver Installation (Optional Function)**

Load drivers form attached CD & find Sub-directories under CT5880 directory.

- Install win9Xdrv if your operation system is win95, 98.
- Install nt4drv if your operation system is NT4.0.
- Install win2000 if your operation system is win2000.

---

## Chapter 2 Installation

### 2-1 Layout Reference

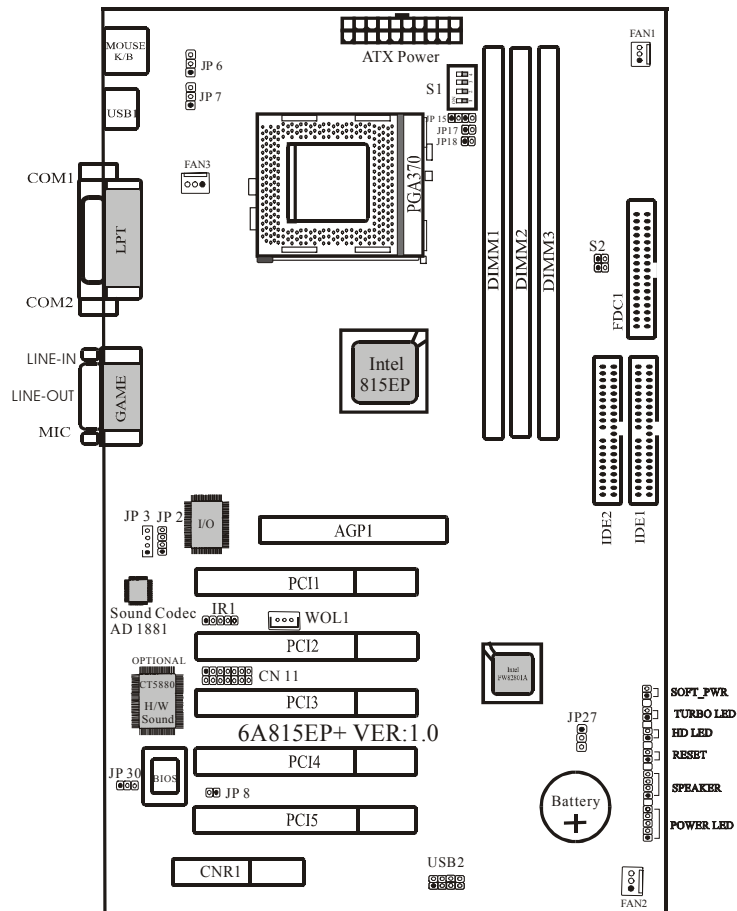

---

## 2-2 Jumper Setting

### 2-2-1 JP6 : Keyboard Wake up Selection

**JP6** is a 3-pin selector which provides keyboard wake up function. Set "1-2" to disable and set "2-3" to enable keyboard wake up function.

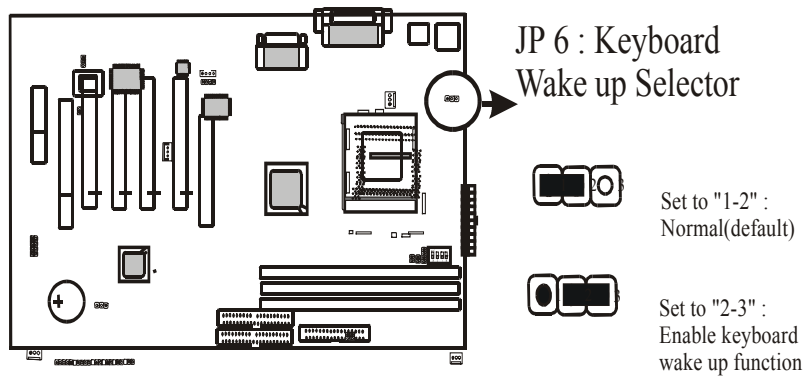

---

## 2-2-2 JP8 : Flash ROM (BIOS) Selection

*JP8* is a 2-pin connector which provides Flash ROM function “**enabled/disabled**” as below.

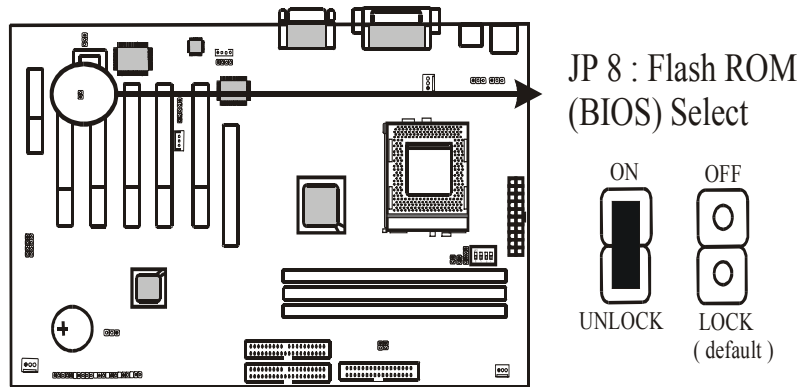

Make sure JP8 is ON (unlock) when you refresh a BIOS.

---

### 2-2-3 JP7 : USB Keyboard Wake Up

JP7 is a 3-pin selector, which provides USB key board wake up function. Set “1-2” to disable & “2-3” to enable USB keyboard wake up function.

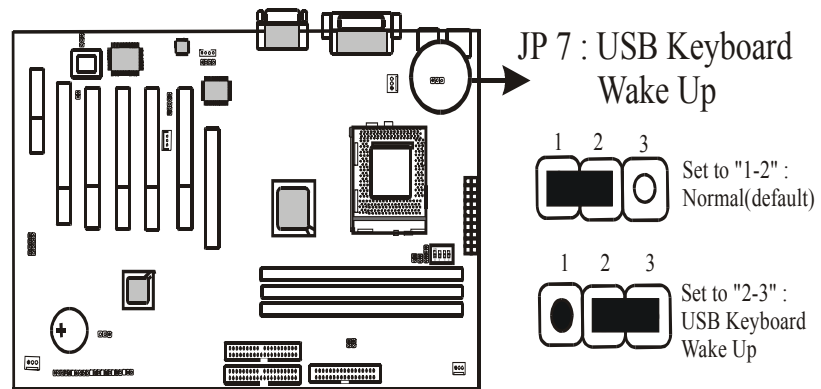



## 2-2-4 S2、JP15、JP17、JP18 : CPU & DIMM Clock Selection

All these jumpers are set to select CPU/ DIMM types for special purposes (not recommended).

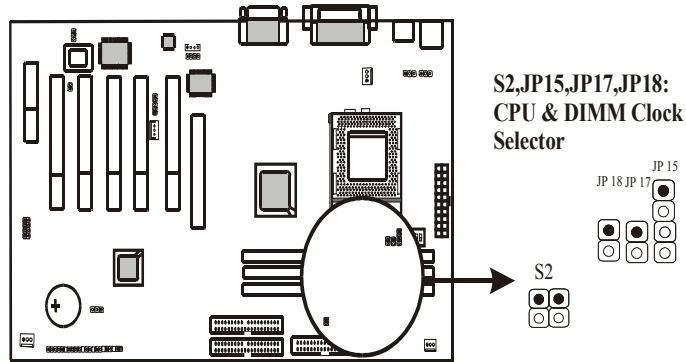

		S2		JP15		JP17	JP18
CPU	DIMM	1	2	1-2	3-4		
66 MHz	100MHz	ON	ON	ON	ON	OFF	OFF
66 MHz	100MHz	ON	ON	OFF	OFF	ON	ON
100MHz	100MHz	OFF	ON	OFF	OFF	ON	OFF
133MHz	133MHz	ON	OFF	OFF	OFF	OFF	OFF
133MHz	100MHz	OFF	OFF	OFF	OFF	OFF	OFF

Frequency auto detect (default)



1. The frequency is auto detected, no need to set jumpers unless you need to adjust them for special purposes (over-clocking).
2. The manufacturer shall have neither liability nor responsibility to any person or entity with respect to any loss or damages arising by users' over-clocking.

---

## 2-2-5 JP 27: RTC – CMOS Status

RTC is a 3-pin connector. Clear CMOS if system password is forgotten. Below are details to show how to clear CMOS.

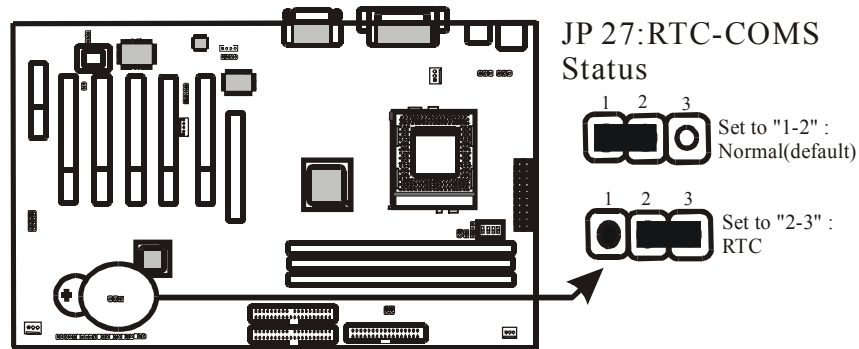

### Procedure to clear CMOS:

- Step 1: Shut down the system and disconnect the power supply from AC power.
- Step 2: Pull out the power supply cable from the power connector.
- Step 3: Short the CMOS jumper by putting jumper cap on Pin 2-3 for a few seconds.
- Step 4: Return the cap to pin 1-2 at normal setup.
- Step 5: Link the power cable to the connector & connect AC power to power supply.
- Step 6: Turn on system power.

 *If you'd like to set password, press "Del" Key during system boot up to enter CMOS setup and establish a new password.*

## 2-2-6 S1:CPU Vcore Selection

S1 is a 4-pin DIP switch which provides CPU Vcore selection to meet customer's special requirements (Over-clocking or over-voltage, but it is not recommended).

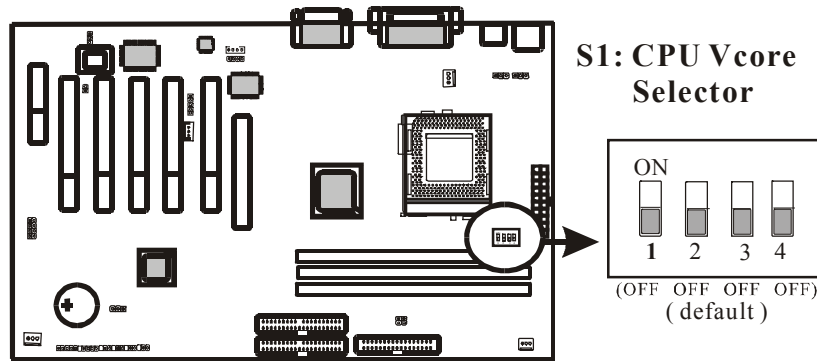

CPU Volt.	S1				
	1	2	3	4	
1.35V		OFF	OFF	OFF	ON
1.40V		OFF	OFF	ON	OFF
1.45V		OFF	OFF	ON	ON
1.50V		OFF	ON	OFF	OFF
1.55V		OFF	ON	OFF	ON
1.60V		OFF	ON	ON	OFF

---

1.65V		OFF	ON	ON	ON
1.70V		ON	OFF	OFF	OFF
1.75V		ON	OFF	OFF	ON
1.80V		ON	OFF	ON	OFF
1.85V		ON	OFF	ON	ON
1.90V		ON	ON	OFF	OFF
1.95V		ON	ON	OFF	ON
2.00V		ON	ON	ON	OFF
2.05V		ON	ON	ON	ON



*CPU will auto-detect Vcore, please don't change default setting. The manufacture shall have neither liability nor responsibility to any person or entity with respect to any loss or damages arising by users' over-clocking or over-voltage.*

---

## 2-2-7 JP30: Creative Sound Function (Optional)

Only on board hardware Creative Sound version main board provides this function.

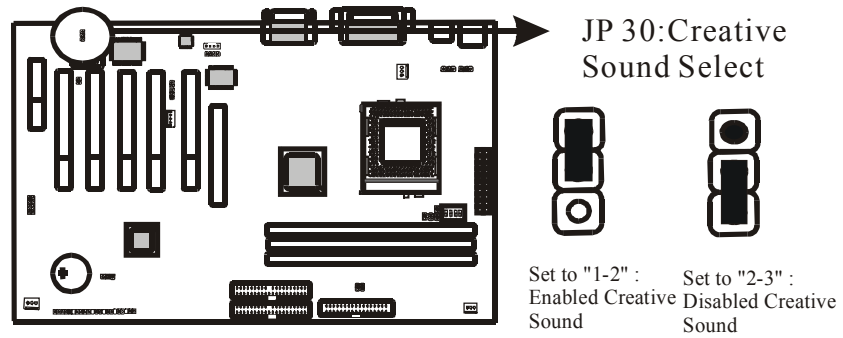

---

## 2-3 Connectors

### 2-3-1 Front Panel

*Front panel* has connectors such as “POWER LED,” “SPEAKER,” “RESET,” “HD LED,” “TURBO LED,” “POWER ON.” Please refer to the following further information.

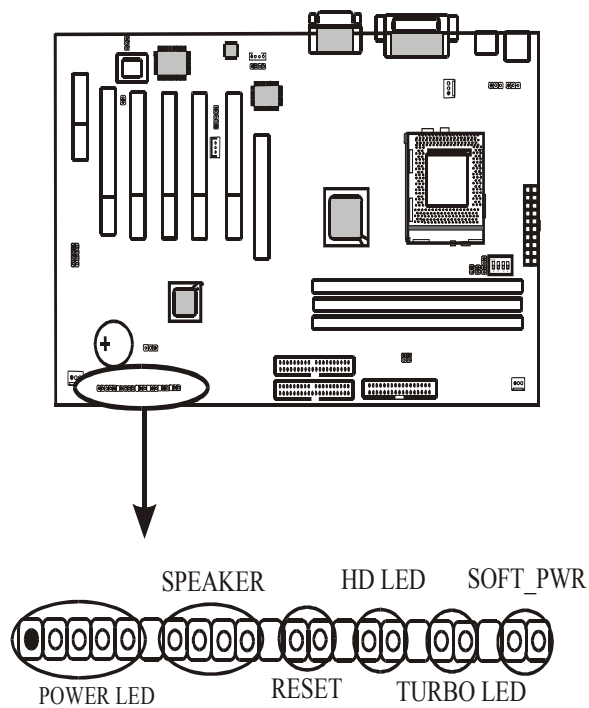

---

**POWER LED** is a 3-pin connector. It is used to connect the LED on the case front panel. The LED shows the status of the power.

**SPEAKER** is a 4-pin keyed Berg strip. It is used to connect to the case speaker to the main board for sound purpose.

**RESET** is a 2-pin keyed Berg strip, connected to the push button reset switch on the case's front panel. Shorting both pin 1 & pin 2 can reset the system, which is similar to the power off and then on again.

**HD LED** (Hard Disk activity LED connector) is a 2-pin keyed Berg strip. It is used to connect to front panel Hard Disk LED.

**TURBO LED** is a 2-pin Berg strip on case front panel indicates the current speed status of system.

**SOFT\_PWR** is for ATX power supply only.

---

### 2-3-2 Back Panel

Back Panel Connectors are GAME Port, MIC, LINE-IN, LINE-OUT, COM1/COM2, LPT, USB1/USB2, PS/2 keyboard, and PS/2 mouse on case back panel.

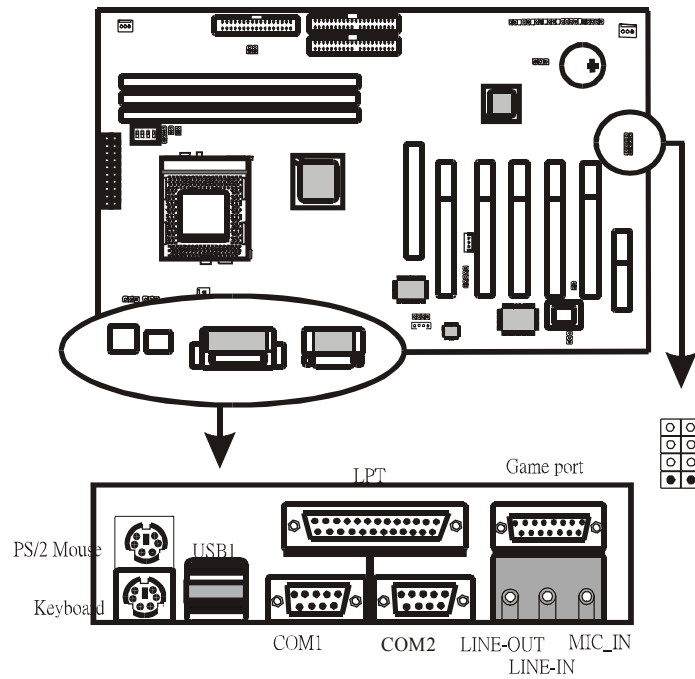



---

## **KBD/PS2 MOUSE**

*The onboard PS/2 keyboard and mouse connectors* are 6-pin Mini-Din connectors.

## **USB1/USB2 : USB (Universal Serial Bus) Connector**

*Universal Serial Bus connector*, marked as “USB1,” is used to connect USB devices. There are 2 USB connectors on this main board.

## **COM1/COM2**

*The onboard serial port 1 and port 2* are the 9-pin D-subminiature male connector COM1 and COM2. COM1 and COM2 can be disabled in BIOS setup. Please refer to Chapter 3 “Integrated Peripherals” for more information.

## **LPT**

*The onboard parallel port* is a 25-pin female connector. It supports standard Printer port, Enhanced Parallel Port (EPP), Extended Capabilities Port (ECP), Standard Parallel Port (SPP).

## **Midi/Game Port & External Audio Connectors**

*Midi/Game port* has 15 pins connecting to the game joystick. External Audio connectors are “LINE-OUT, LINE-IN, MIC-IN” for audio functions.

---

### 2-3-3 ATX Power Supply Connector

*ATX power connector* has 20 pins, which is especially designed for ATX case. The ATX power supply supports the function of the “**Soft Power On Momentary Switch**” which connects the front panel switch to the 2-pin **SOFT-PWR** on the system board. While the power switch on the back of ATX power is turned on, the full power will not go into the system board until the front panel switch is momentarily pressed. Push the switch again to turn off the power to the system board.

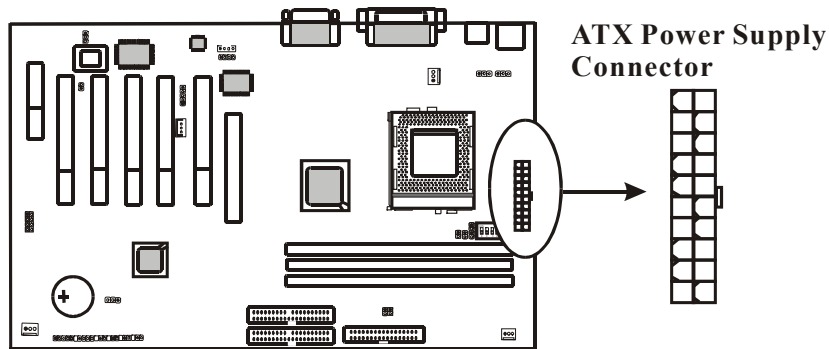

*To support i815EP chipset, we suggest that Pin 17 signal 5VSB on ATX Power supply should be able to offer at least 1A driving ability.*

---

### 2-3-4 CPU Fan Connectors

*There are 3 fan connectors* on this system board, and it is marked as “FAN1”, “FAN2”, “FAN3”. Each fan connector has three pins.

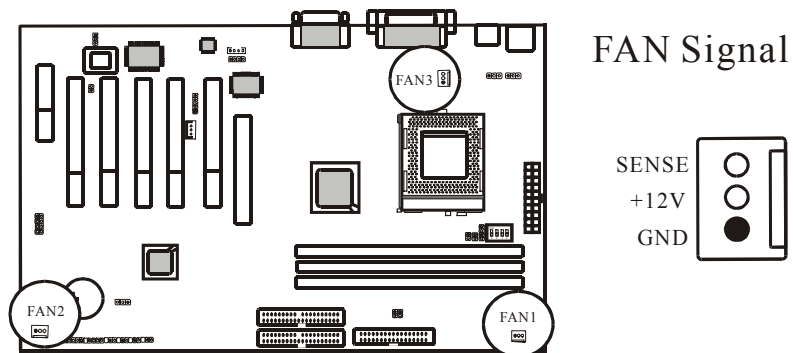

---

### 2-3-5 IR2 : IrDA Connector

**IR connector** supports wireless infrared module. With this module and application software like Laplink, or Win95 Direct Cable Connection, user can transfer data to or from laptops, notebooks, PDA and printers. This connector supports **HPSIR**, **ASKIR**, and **Fast IR**.

Attach Infrared module to IR connector. Be sure to put in the right direction during installation.

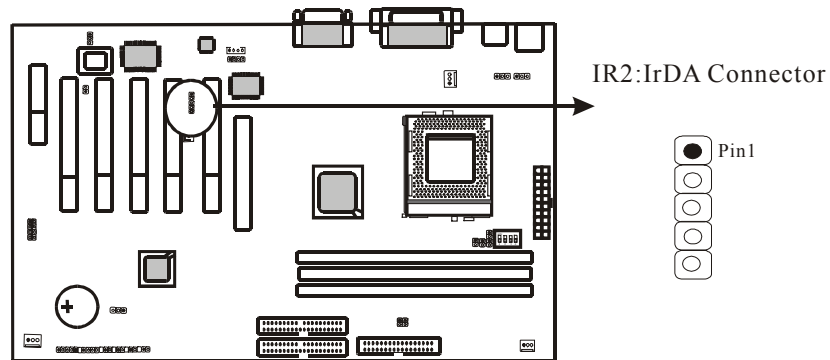

	<b>IR2</b>
<b>1</b>	VCC
<b>2</b>	NONE
<b>3</b>	IRRX
<b>4</b>	GND
<b>5</b>	IRTX

---

### 2-3-6 JP2/JP3: CD\_IN

CD\_IN is a CD ROM external audio input signal to line-out (speaker) of the main board.

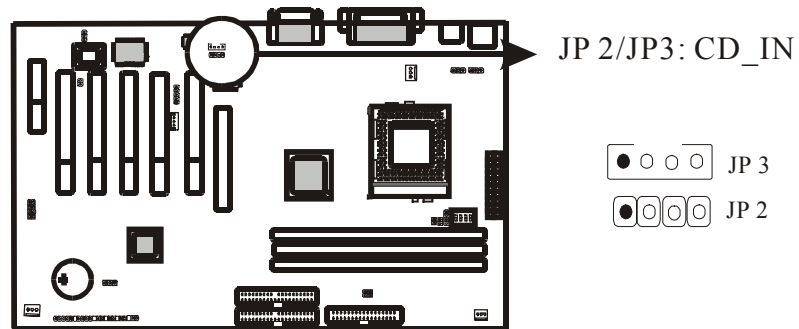

---

### 2-3-7 Floppy Disk Connector

*Floppy Disk Connector* has 34 pins and is used to attach the floppy drive cable.

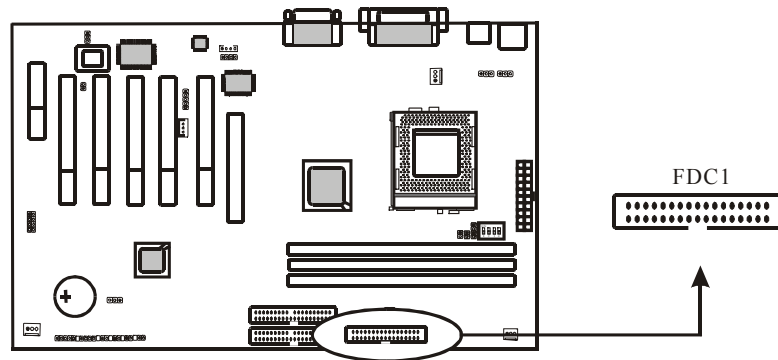

---

### 2-3-8 IDE1 & IDE2

*IDE1 and IDE2* are 39-pin IDE connectors (Ultra 66/Ultra 100). **IDE1** is primary channel, and **IDE2** is secondary channel. Each channel supports 2 IDE devices, and 4 devices in total for this main board.

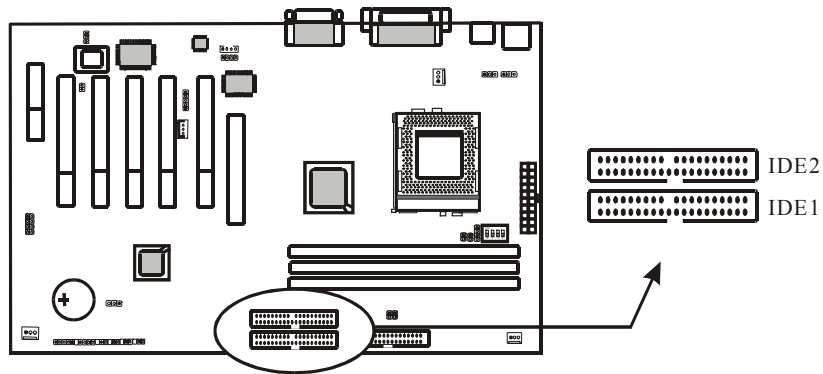

---

### 2-3-9 WOL1 : Wake up on LAN

*Wake up on LAN*, marked as “WOL1,” is a 3-pin connector. To support this feature, a network card is required for the system and network management software must be installed too.

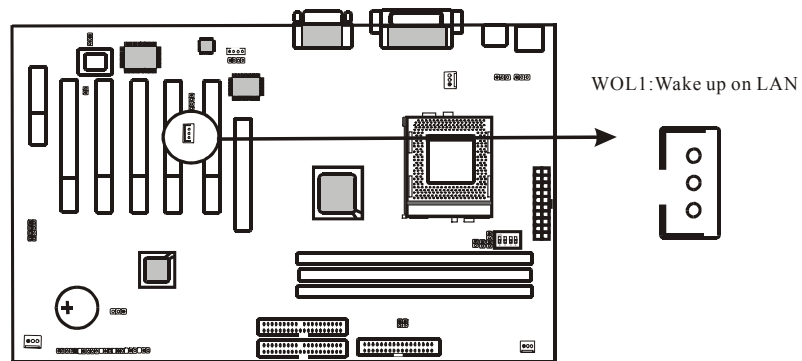

***WOL(Wake up on LAN) function requirement:***

***Power supply should be able to offer at least 1A driving ability to the signal “5V trickle voltage.”***



---

### 2-3-10 CN11: Smart Card Reader Connector(Optional)

The Smart Card is capable of providing secured storage facilities for sensitive personal information (such as Private Keys, Account numbers, Passwords, Medical information, etc...). The Smart Card Reader can be used for a broad range of application in GSM, ID, pay TV, banking,... and so forth.

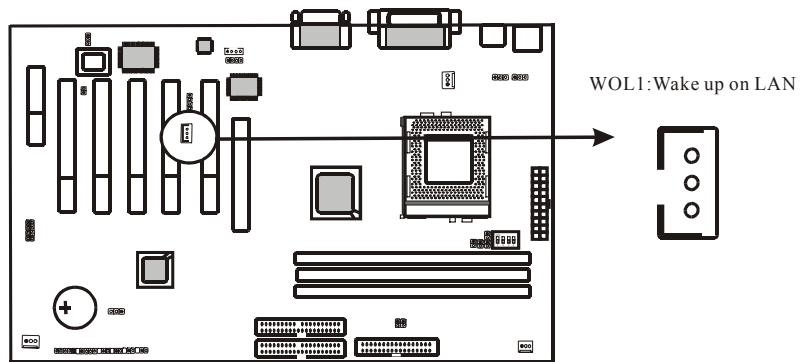

---

## 2-4 DIMM Installation

Please make sure DIMM is 3.3V DIMM. Either DIMM1, DIMM2 or DIMM3 supports 8 MB, 16 MB, 32 MB, 64 MB, and 128MB. Maximum memory for **SDRAM is up to 512 MB.**

Insert the module as shown. Due to different number of pins on either side of the breaks, the module will only fit in the direction as shown. SDRAM DIMM modules have different pin contacts on each side and therefore have a higher pin density.

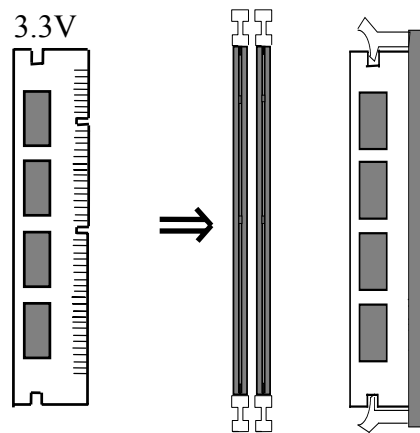

*SDRAM memory supports PC-100/PC-133 DIMM.*

---

## Chapter 3 PhoenixNet™ BIOS Porting Guide

### 3-1 Product Overview

PhoenixNet™ is an end-user content service that displays system configuration during the power on of a Personal Computer, and delivers promotional icons to the desktop.

PhonixNet delivers 1) one-click, easy access to the Internet, 2) offers from leading Internet companies, and 3) anti-virus protection(Trend ChipAway Virus™) as well as other free offers.

Each of the components has specific functionality and the interactions between the components and the effects that each has upon the other will be examined in this document.

---

## 3-2 Graphical Launch Screen (GLS)

The first ROMSmarts component, GLS, displays a graphical screen to the user early in the boot process, as the first image displayed on the screen. This display remains on the screen throughout the normal BIOS initialization phase called POST.

The GLS component will replace the old text-based POST with a full graphical screen. The screen will display PC metrics such as CPU vendor, model and speed, memory and hard disk size.

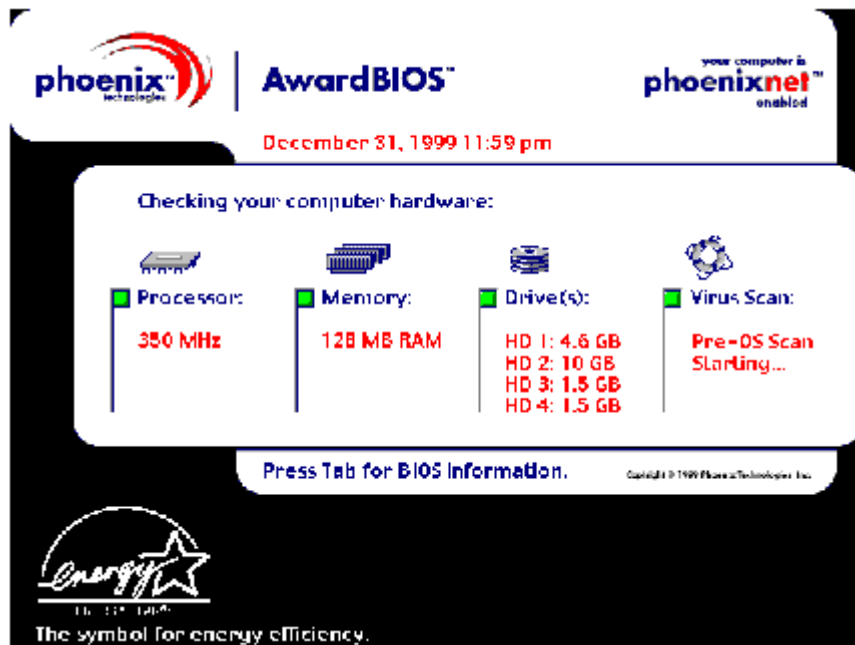

---

## Chapter 4 BIOS Setup

### 4-1 Award<sup>®</sup> BIOS CMOS Setup

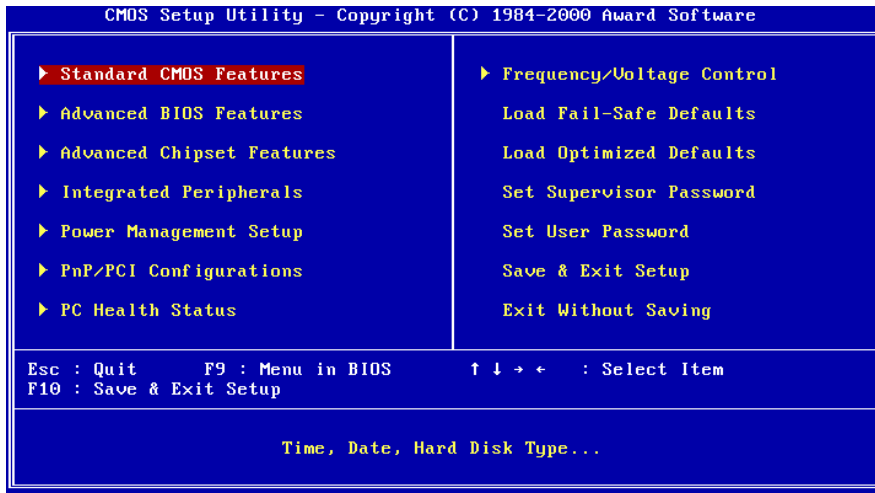

The menu displays all the major selection items and allows user to select any of the shown item. The selection is made by moving cursor (press any direction key) to the item and press <Enter> key. An on-line help message is displayed at the bottom of the screen as cursor is moved to various items which provide user better understanding of each function. When a selection is made, the menu of the selected item will appear. So the user can modify associated configuration parameters.

---

## 4-1-1 Standard CMOS Features

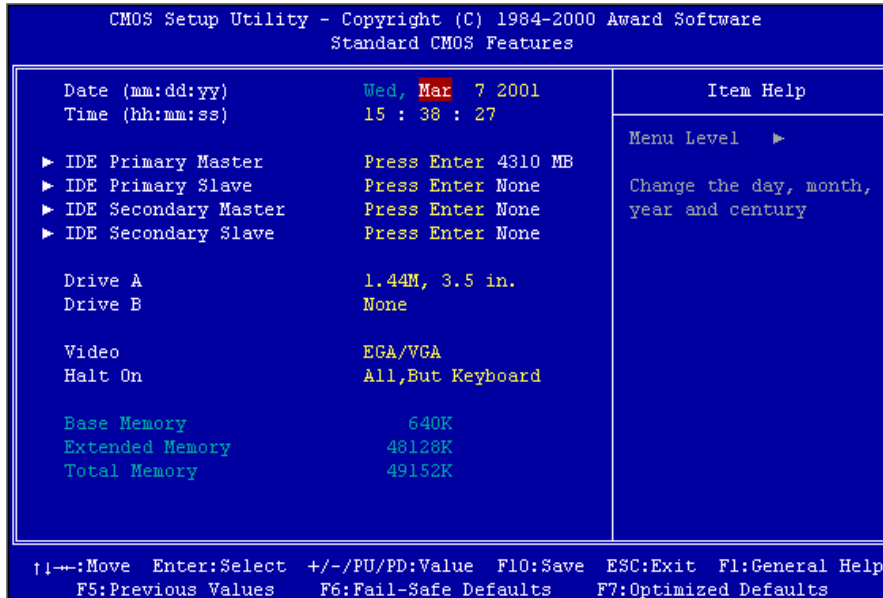

The "Standard CMOS Features" allows user to configure system setting such as **current date and time, type of hard disk drive** installed in the system, **floppy drive type**, and the type of **display monitor**. Memory size is auto detected by the BIOS and displayed for your reference. When a field is highlighted (direction keys to move cursor and <Enter> key to select). The entries in the field will be changed by pressing <PageDown> or <PageUp> key or user can enter new data directly from the keyboard.

CMOS Setup Utility - Copyright (C) 1984-2000 Award Software		
IDE Primary Master		
IDE HDD Auto-Detection	Press Enter	Item Help
IDE Primary Master	Auto	Menu Level >>
Access Mode	Auto	To auto-detect the
Capacity	4310 MB	HDD's size, head... on
Cylinder	14848	this channel
Head	9	
Precomp	65535	
Landing Zone	14847	
Sector	63	

↑|←:Move Enter:Select +/-/PU/PD:Value F10:Save ESC:Exit F1:General Help  
F5:Previous Values F6:Fail-Safe Defaults F7:Optimized Defaults

---

## Hard Disk Configurations

- 1. IDE HDD Auto-Detection** : press this item to Auto Detect the HDD type.
- 2. IDE Primary Master** : select "AUTO" to detect the mode type automatically. Select "NORMAL" users have to redefine the following 4-8 items according to HDD. "NONE" means this item disabled.
- 3. ACCESS MODE** : select "AUTO" to detect the mode type automatically. If your hard disk supports the **LBA** mode, select "**LBA**" or "**LARGE**". However, if your hard disk cylinder is more than 1024 and does not support the LBA function, you have to set at "**LARGE**." Select "**CHS**" for user type. **CHS (Cylinder Head Sector)** is for old type HDD.
- 4. CYLS** : the cylinder number of the hard disk.
- 5. HEAD** : the read/write head number of hard disk. The range is from "**1**" to "**16**".
- 6. PRECOMP**: the cylinder number at which the disk drive changes the write timing.
- 7. LANDING ZONE** : the cylinder number that the disk drive heads (read/write) are seated when the disk drive is parked.
- 8. SECTOR** : the sector number of each track defined on the hard disk. The range is from "**1**" to "**64**".



**Note 1:** if hard disk's primary master/slave and secondary master/slave were set to "**auto**", the hard disk size and model will be auto detected on display during POST.



**Note 2:** "**halt on**" is to determine when to halt the system by the BIOS if error occurred during POST.



---

## 4-1-2 Advanced BIOS Features

Menu below shows all of the manufacturer's default values of this main board. Move the cursor by pressing <PageDown>/- or <PageUp>/+ key to modify the parameters, press [F1] key to display help message of the selected item. This setup program also provide 2 convenient ways to load the default parameter data from BIOS [F6] and [F7] area if shown data is corrupted. This provides the system a capability to recover from any possible error.

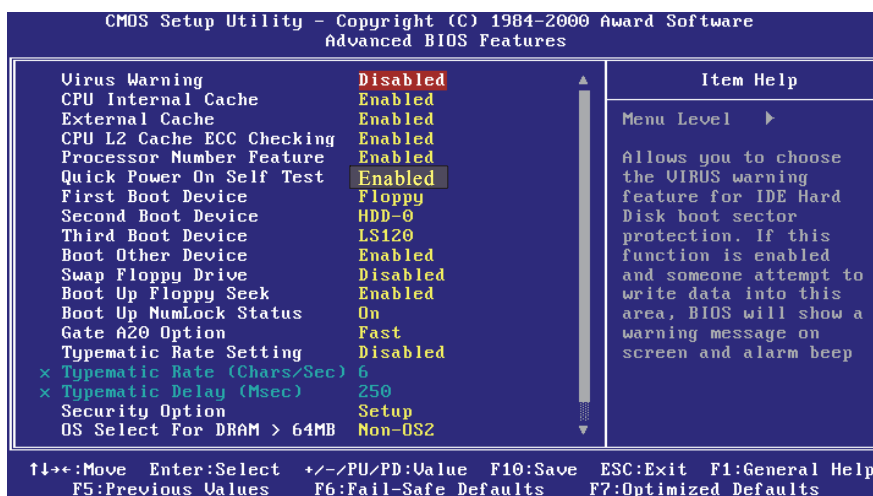

***Virus Warning***  
**:Enabled**  
**:Disabled (default)**

---

***CPU Internal Cache***

**Enabled :** enable L1 cache (default)

**Disabled:** disable L1 cache

***External Cache***

**Enabled:** enable L2 cache (default)

**Disabled:** disable L2 cache

***CPU L2 Cache ECC Checking***

**Enabled:** enable L2 cache ECC checking(default)

**Disabled:** disable L2 cache ECC checking

***Processor Number Feature***

**:Enabled** (default)

**:Disabled**

***Quick Power On Self Test***

This category speeds up power on self test.

**Enabled:** BIOS will shorten or skip some check items. (default)

**Disabled:** normal speed

***First Boot Device***

This category determines which drive the system searches first. System will search in turn for floppy disk drive; second is hard disk drive, and finally Floppy drive. Default value is "**FLOPPY**". Options are as below:

**FLOPPY; LS120; HDD-0; SCSI; CDROM; HDD-1; HDD-2; HDD-3; ZIP100; LAN; Disabled**

***Second Boot Device***

This category determines which drive the system searches first. System will search in turn for floppy disk drive; second is hard disk drive, and finally Floppy drive. Default value is "**HDD-0**". Options are as below:

**FLOPPY; LS120; HDD-0; SCSI; CDROM; HDD-1; HDD-2; HDD-3; ZIP100;LAN; Disabled**

---

### ***Third Boot Device***

This category determines which drive the system searches first. System will search in turn for floppy disk drive; second is hard disk drive, and finally Floppy drive. Default value is “**LS120**”. Options are as below:

**FLOPPY; LS120; HDD-0; SCSI; CDROM; HDD-1; HDD-2; HDD-3; ZIP100; LAN; Disabled;**

### ***Boot Other Device***

**:Enabled** (default)

**:Disabled**

### ***Swap Floppy Drive***

**Enabled:** floppy A&B will be swapped.

**Disabled:** floppy A&B will not be swapped. (default)

### ***Boot Up Floppy Seek***

BIOS will determine if the floppy disk drive is 40 or 80 tracks. 360k type is 40 tracks while 720K/ 1.2M and 1.44M are all 80 tracks. Default value is **Enabled**.

**:Disabled**

**:Enabled**

### ***Boot Up Numlock Status***

**:On** (default)

**:Off**

### ***Gate A20 Option***

**:Normal**

**:Fast** (default)

### ***Typematic Rate Setting***

This determines the typematic rate.

**Enabled:** enable typematic rate and typematic delay programming.

**Disabled**(default) : disable typematic rate and typematic delay programming. The system BIOS will use default value of this 2 items and the default is controlled by keyboard.

---

**Typematic Rate(Chars/Sec)**

6: 6 Characters Per Second (default)

8, 10, 12, 15, 20, 24, 30: 8, 10, 12, 15, 20, 24, 30 Characters Per Second

**Typematic Delay (Msec)**

This is the interval between the first and second character displayed.

**250** : 250 msec (default)

**500** : 500 msec

**750** : 750 msec

**1000** : 1000 msec

**Security Option**

Item	Function	Note
Setup (default)	Security protection in CMOS setup menu	After setting password in BIOS CMOS “ <b>Supervisor Password</b> ” or <b>User Password,</b> ” it protects BIOS CMOS setup.
System	Security protection in system boot-up & BIOS setup	This function secures the system under system boot-up and BIOS setup after setting password.

**OS Select For DRAM> 64MB**

This option is especially set for OS2 operating system. Set “**Non-OS2**” for RAM memory over 64MB and set “**Non-OS2**” for other operating systems like Windows® 95/98 or NT.

:**Non-OS2** (default)

:**OS2**

**Report No FDD For WIN 95**

:**No** (default)

:**Yes**

---

### 4-1-3 Advanced Chipset Features

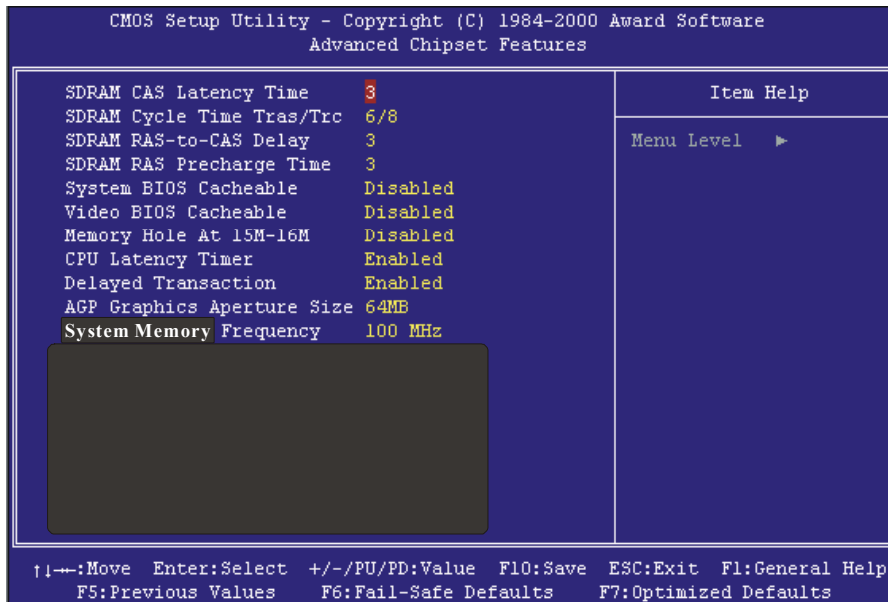

#### *SDRAM CAS Latency Time*

: 2  
: 3 (default)

#### *SDRAM Cycle Time Tras/Trc*

: 5/7  
:6/8 (default)

---

***SDRAM RAS-to-CAS Delay***

**:3** (default)

**:2**

***SDRAM RAS Precharge Time***

SDRAM precharge time by RAS

**: 3** (default)

**: 2**

***System BIOS Cacheable***

It defines whether system BIOS area cacheable or not.

**:Disabled** (default)

**:Enabled**

***Video BIOS Cacheable***

It defines whether video BIOS area cacheable or not.

**:Disabled** (default)

**:Enabled**

***Memory Hole at 15M-16M:*** this field enables a memory hole in main memory space. CPU cycles matching an enabled hold are passed on to PCI note that a selection can not be changed while the L2 cache is enabled.

**:Disabled** (default)

**:Enabled**

***CPU Latency Timer***

**:Disabled**

**:Enabled** (default)

***Delayed Transaction***

**:Disabled**

**:Enabled** (default)

***AGP Graphics Aperture Size***

**: 64MB** (default)

**: 32MB**

---

*System Memory Frequency*

: **100MHz** (default)

: **133MHz**

: **Auto**

---

## 4-1-4 Integrated Peripherals

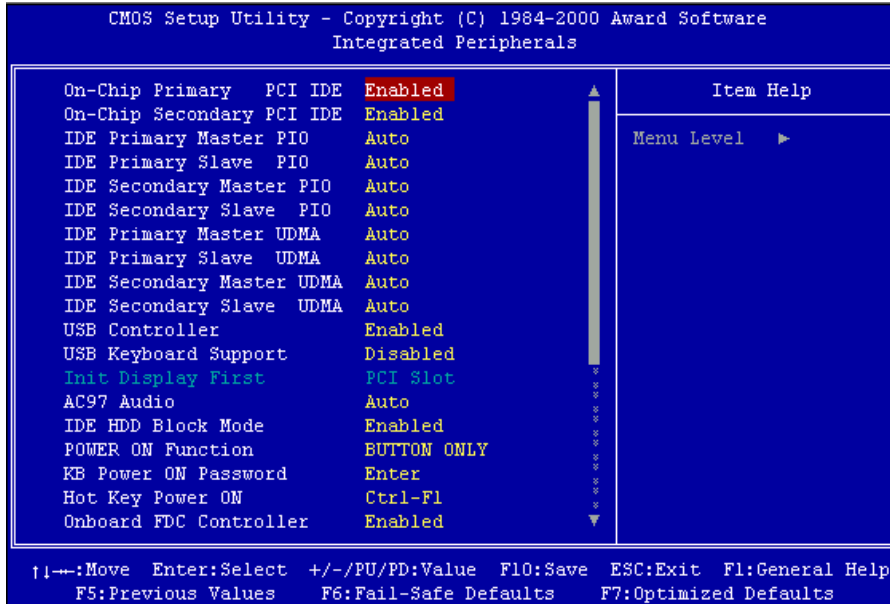

### *OnChip Primary PCI IDE*

:Disabled

:Enabled (default)

### *OnChip Secondary PCI IDE*

:Disabled

:Enabled (default)

### *IDE Primary Master PIO*

This feature detects your primary master hard disk device.

:Auto (default)

:Mode 0,1,2,3,4



---

***IDE Primary Slave PIO***

This feature detects your primary master hard disk device.

**:Auto** (default)

**:Mode 0,1,2,3,4**

***IDE Secondary Master PIO***

This feature detects your secondary master hard disk device.

**:Auto** (default)

**:Mode 0,1,2,3,4**

***IDE Secondary Slave PIO***

This feature detects your secondary master hard disk device.

**:Auto** (default)

**:Mode 0,1,2,3,4**

***IDE Primary Master UDMA***

**:Disabled**

**:Auto**(default)

***IDE Primary Slave UDMA***

**:Disabled**

**:Auto**(default)

***IDE Secondary Master UDMA***

**:Disabled**

**:Auto**(default)

***IDE Secondary Slave UDMA***

**:Disabled**

**:Auto**(default)

***USB Controller***

**:Enabled**(default)

**:Disabled**

---

***USB Keyboard support***

**:Disabled**(default)

**:Enabled**

***Init Display First***

**:PCI Slot**

***AC97 Audio*** (For AC-97 Sound Codec use only)

**:Auto**(default)

**:Disabled**

***AC97 Modem*** (For AC-97 Sound Codec use only)

**:Auto** (default)

**:Disable**

***IDE HDD Block Mode***

**:Enabled**(default)

**:Disabled**

***POWER ON Function***

**:Password**

**:Hot KEY**

**:Mouse Move**

**:Mouse Click**

**:Any KEY**

**:BUTTON ONLY**(default)

**:Keyboard 98**

***KB Power ON Password***

**:Enter** (default)

***Hot Key Power ON***

**:Ctrl-F1**(default)

**:Ctrl-F2 ~Ctrl-F12**

---

***Onboard FDC Controller***

**:Disabled**  
**:Enabled (default)**

***Onboard Serial Port 1***

**:Disabled**  
**:3F8/IRQ4 (default)**  
**:2F8/IRQ3**  
**:3E8/IRQ4**  
**:2E8/IRQ3**  
**:Auto**

***Onboard Serial Port 2***

**:Disabled**  
**:3F8/IRQ4**  
**:2F8/IRQ3 (default)**  
**:3E8/IRQ4**  
**:2E8/IRQ3**  
**:Auto**

***UART Mode Select***

**:Normal (default)**  
**:IrDA**  
**:ASKIR**  
**:SCR**

***UR2 Duplex Mode***

**:Full**  
**:Half (default)**

***Onboard Parallel Port***

**:Disabled**  
**:378/IRQ7 (default)**  
**:278/IRQ5**  
**:3BC/IRQ7**

---

***Parallel Port Mode***

**: SPP** (default)  
**: EPP**  
**: ECP**  
**: ECP + EPP**

***ECP Mode Use DMA***

**:1**  
**:3**(default)

***PWRON After PWR-Fail***

**:Off** (default)  
**:On**  
**:Former-Sts**

***Game Port Address***

**:Disabled**  
**:201** (default)  
**:209**

***Midi Port Address***

**:Disabled** (default)  
**: 330**  
**: 300**

***Midi Port IRQ***

**:10** (default)  
**:5**

---

## 4-1-5 Power Management Setup

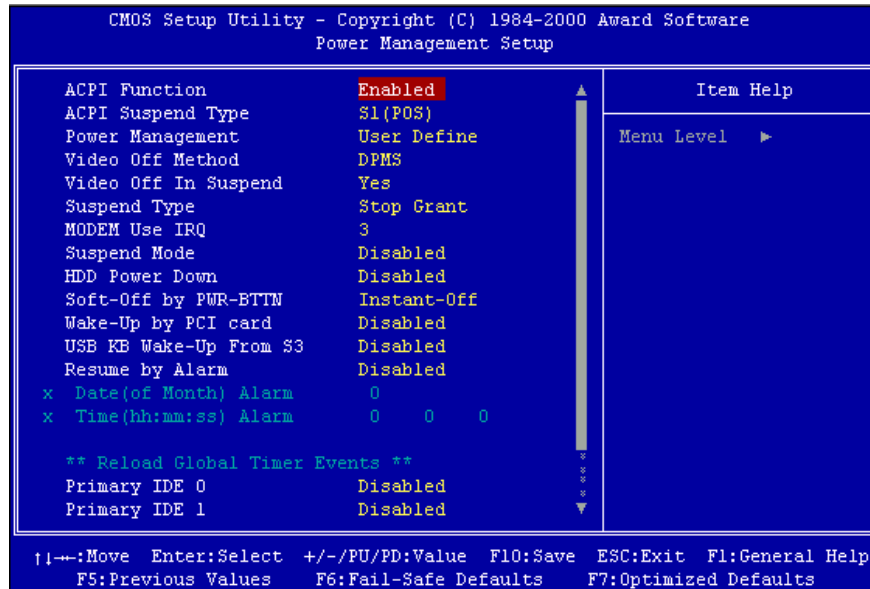

---

***ACPI Function***

**:Enabled** (default)

**:Disabled**

***ACPI Suspend Type***

**:S1(POS)** (default)

**:S3(STR)**

***Power Management***

**:User Define**(default) --- users can configure their own power management

**:Min Saving**

**:Max Saving**

***Video Off Method***

**:Blank Screen**

**:V/H Sync+Blank**

**:DPMS** (default)

***Video Off In Suspend***

**:No**

**:Yes** (default)

***Suspend Type***

**:Stop Grant** (default)

**:PwrOn Suspend**

***MODEM Use IRQ***

**:3** (default)

**: NA, 4, 5, 7, 9, 10, 11**

***Suspend mode***

**:Disabled**(default)

**:1min, 2 min, 4 min, 8 min, 12 min, 20 min, 30 min, 40 min, 1 Hour**

---

***HDD Power Down***

**:Disabled**(default)

**:1 min --- 15 min**

***Soft-Off by PWR-BTN***

**:Instant-Off** (default)

**:Delay 4 Sec.**

***Wake-Up by PCI card***

**:Disabled** disble this function (default)

**:Enabled** modem ring on function---system can be turned on through modem.

***USB KB Wake-Up From S3***

**:Disabled**(default)

**:Enabled**

***Resume by Alarm***

**:Disabled** (default)

**:Enabled**

***Primary IDE 0***

**:Disabled** (default)

**:Enabled**

***Primary IDE 1***

**:Disabled** (default)

**:Enabled**

***Secondary IDE 0***

**:Disabled** (default)

**:Enabled**

***Secondary IDE 1***

**:Disabled** (default)

**:Enabled**

---

***FDD, COM, LPT Port***

**:Disabled** (default)

**:Enabled**

***PCI PIRQ[A-D]#***

**:Disabled** (default)

**:Enabled**



---

## 4-1-6 PnP / PCI Configuration Setup

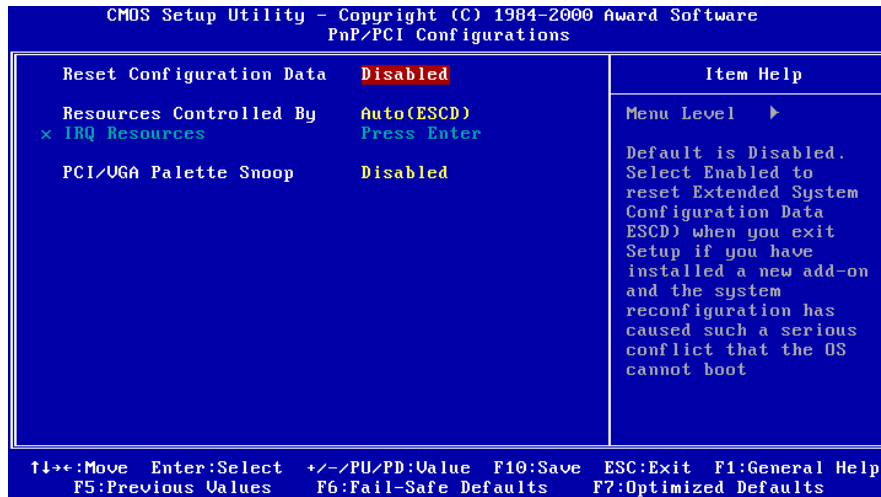

---

***Reset Configuration Data***

**:Disabled**(default)

**:Enabled---** to reset “**Extended System Configuration Data(ESCD)** when you exit setup if you have installed a new add-on card and the system reconfiguration has caused such a serious conflict that the operating system can not boot up.

***Resources Controlled By***

**:Manual**

The table will show the below items: “**Reset Configuration Data, IRQ-3 assigned to.**” The user can adjust the shown items as required.

**:Auto(ESCD)** (default)

The table will not show the above items, and the system will automatically assign the above setup.

***PCI/VGA Palette Snoop***

**:Disabled** (default)

**:Enabled**

***INT Pin 1 Assignment***

**:Auto**(default)

***INT Pin 2 Assignment***

**:Auto**(default)

***INT Pin 3 Assignment***

**:Auto**(default)

***INT Pin 4 Assignment***

**:Auto**(default)

---

## 4-1-7 PC Health Status

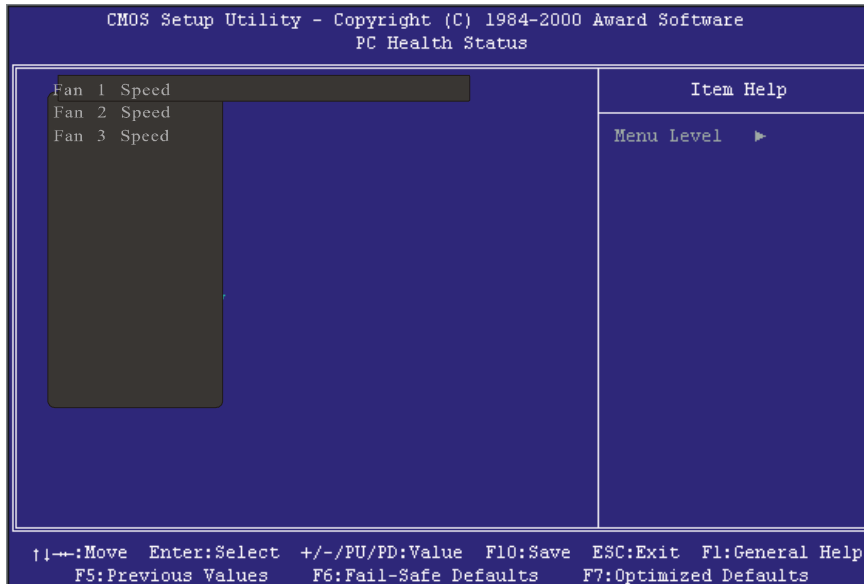

***Current CPU Fan1 Speed/Fan2 Speed/Fan3 Speed:***  
System will automatically detect the above items and show the status.

---

## 4-1-8 Frequency/Voltage Control

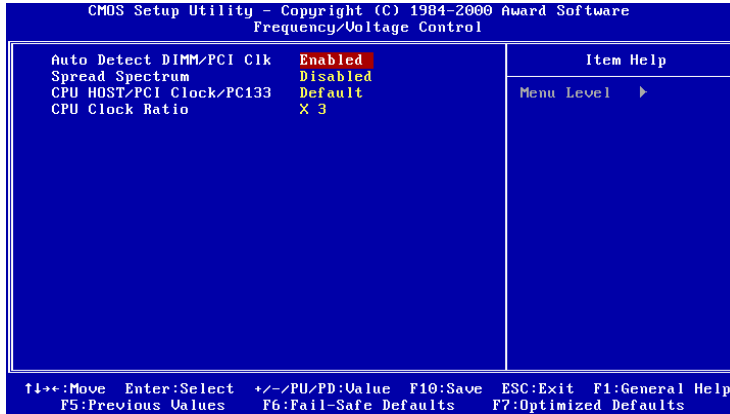

### *Auto Detect DIMM/PCI Clk*

: Enabled (default)

: Disabled

### *Spread Spectrum*

: Disabled (default)

: Enabled

### *CPU HOST/PCI Clock/PC133*

:Default (Default)

: 133/33Mhz/Yes, 137/34Mhz/Yes, 140/35Mhz/Yes, 145/36Mhz/Yes,  
150/37Mhz/Yes, 160/38Mhz/Yes, 166/42Mhz/Yes

### *CPU Clock Ratio*

:X3(default)

:X3.5, X 4, X 4.5, X 5, X 5.5, X 6, X 6.5, X 7, X 7.5, X 8



*This selection is reserved for manufacturers to pass CE test only not available for users.*

---

#### 4-1-9 Load Fail-Safe Defaults

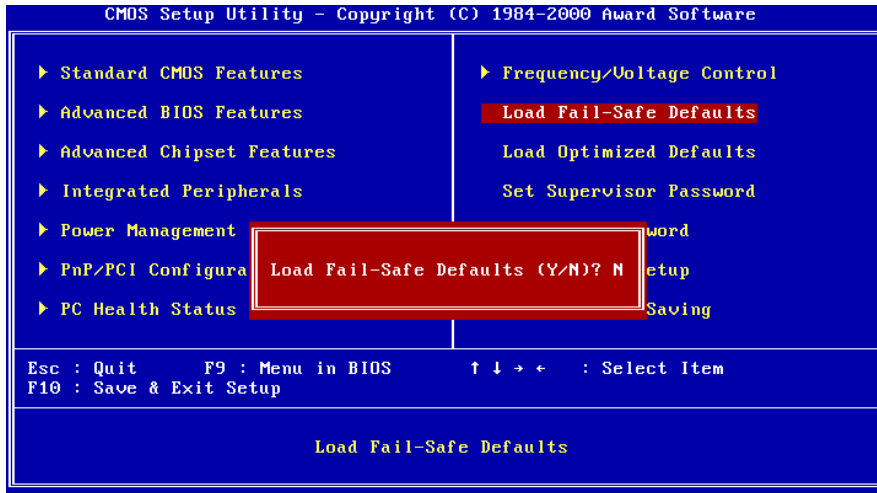

"**Load Fail-Safe Defaults**" loads optimized settings which are stored in the BIOS ROM. The auto-configured settings only affect "**BIOS Features Setup**" and "**Chipset Features Setup**" screens. There is no effect on the standard CMOS setup. To use this feature, highlight it on the main screen and press the <Enter> key. A line will appear on screen asking if you want to load the setup default values. Press the <Y> key and then press the <Enter> key. The setup defaults will then load. If not, enter <N>.

---

## 4-1-10 Load Optimized Defaults

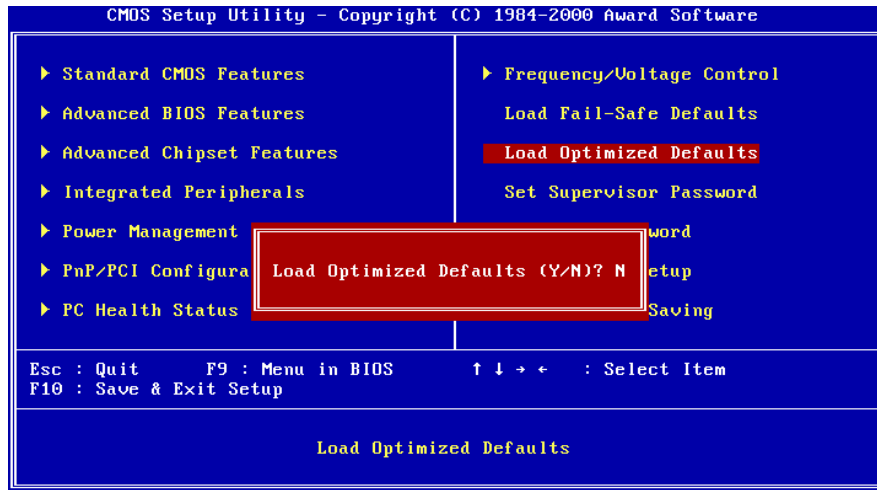

"Load Optimized Defaults" loads optimized settings which are stored in the BIOS ROM. The auto-configured settings only affect "BIOS Features Setup" and "Chipset Features Setup" screens. There is no effect on the standard CMOS setup. To use this feature, highlight it on the main screen and press the <Enter> key. A line will appear on screen asking if you want to load the setup default values. Press the <Y> key and then press the <Enter> key. The setup defaults will then load. If not, enter <N>.

---

## 4-1-11 Supervisor/User Password

The "Supervisor/User Password setting" utility sets the security protection. There are two kinds of password functions in the setup menu : one is "Supervisor Password," and the other is "User Password." Their difference is:

**Supervisor Password:** this function allows you the right to change the options of setup menu.

**User Password:** this function only allows you to enter the setup menu but not to change the options of the setup menu except "USER PASSWORD," "SAVE & EXIT SETUP," and "EXIT WITHOUT SAVING."

### 1. How to set "Supervisor Password" & "User Password"

The setup of "Supervisor Password" and "User Password" has the same steps.

Step 1: Enter Password --Press <Enter> after appointing the password.

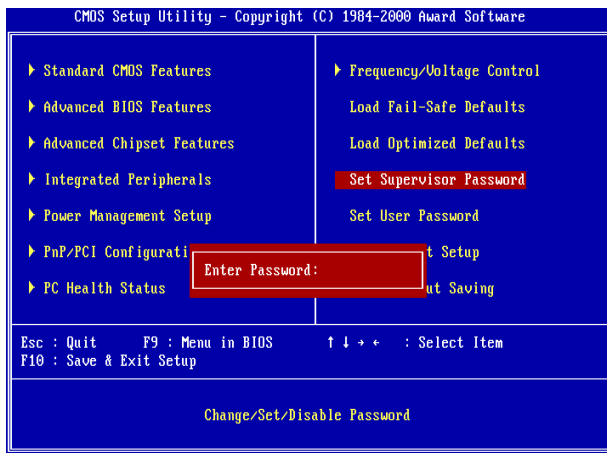

---

### Step 2: Confirm Password

Type the password again and press <Enter>.

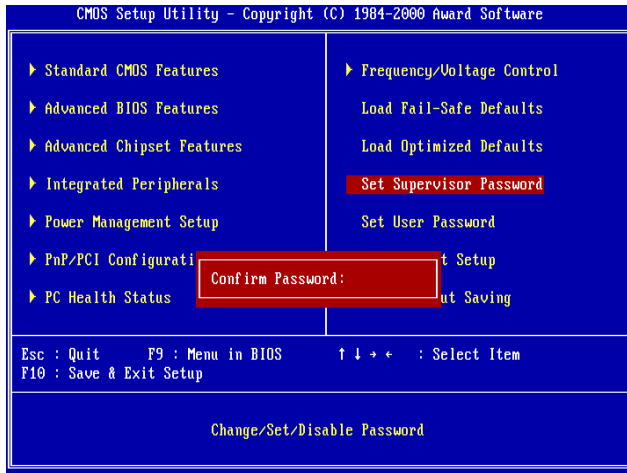

If you forget password, please clear CMOS.  
(refer to jumper RTC1)

### Step 3: Set “Security Option” in “BIOS Features Setup”

After setting password, enter “Security Option” in “BIOS Features Setup.” There are 2 options “Setup” & “System.” “Setup” will only secure CMOS setup through password. “System” is to secure PC system and password is required during system boot-up in addition to CMOS setup.



---

## 2. How to Disable “Supervisor Password” & “User Password”

Step 1: Go to CMOS Setup Menu (need to key in password first)

Step 2: Enter “Supervisor Password” or “User Password”

When it shows “Enter Password.” Press the <Enter> key instead of entering a new password when "ENTER PASSWORD" appears. It will inform “PASSWORD DISABLED PRESS ANY KEY TO CONTINUE.” Thus, press any key as instructed to disable the password.

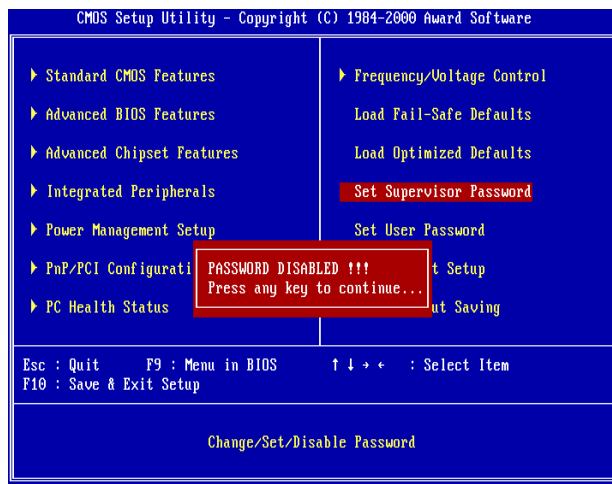

---

## 4-1-12 Save & Exit Setup

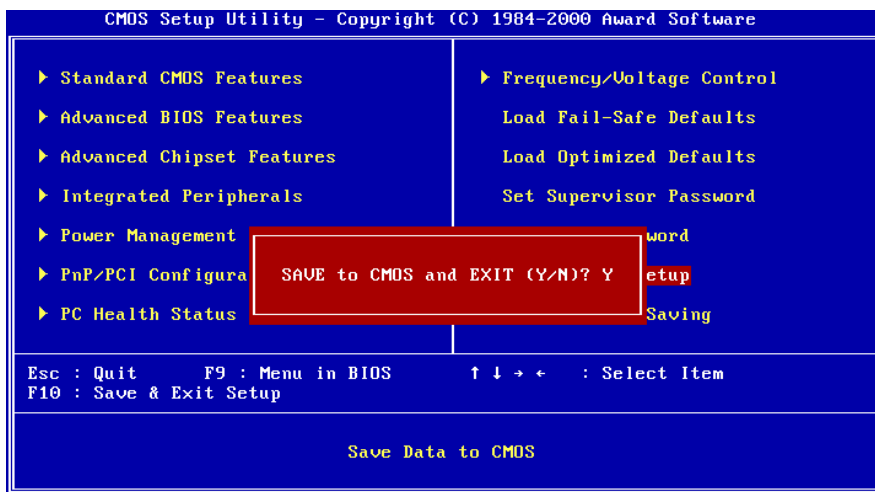

The "Save & Exit Setup" option will bring you back to boot up procedure with all the changes you have made which are recorded in the CMOS RAM.

---

## 4-1-13 Quit Without Saving

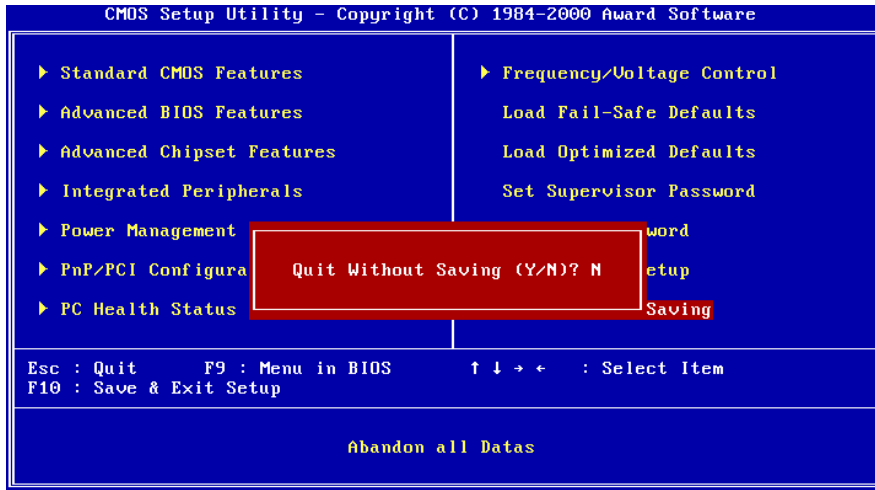

The "**Quit Without Saving**" option will bring you back to normal boot up procedure without saving any data into CMOS RAM. All of the old data in the CMOS will not be destroyed.

---

## Chapter 5      Appendix

### 5-1   Memory Map

Address range	Size	Description
00000-7FFFF	512K	Conventional memory
80000-9FBFF	127K	Extended conventional memory
9FC00-9FFFF	1K	Extended BIOS data area if PS/2 mouse is installed
A0000-C7FFF	160K	Available for hi DOS memory
C8000-DFFFF	96K	Available for hi DOS memory and adapter ROMs
E0000-EEFFF	60K	Available for UMB
EF000-EFFFF	4K	Video service routine for monochrome & CGA adapter
F0000-F7FFF	32K	BIOS CMOS setup utility
F8000-FCFFF	20K	BIOS runtime service routine (2)
FD000-FDFFF	4K	Plug and play escd data area
FE000-FFFFF	8K	BIOS runtime service routine (1)

---

## 5-2 I/O Map

000-01F	DMA controller (master)
020-021	Interrupt controller (master)
022-023	Chipset control registers. I/O ports
040-05F	Timer control registers
060-06F	Keyboard interface controller (8042)
070-07F	RTC ports & CMOS I/O ports
080-09F	DMA register
0A0-0BF	Interrupt controller (slave)
0C0-0DF	DMA controller (slave)
0F0-0FF	Math coprocessor
1F0-1FB	Hard disk controller
278-27F	Parallel port 2
2B0-2DF	Graphics adapter controller
2F8-2FF	Serial port 2
360-36F	Network ports
378-37F	Parallel port 1
3B0-3BF	Monochrome & parallel port adapter
3C0-3CF	EGA adapter
3D0-3DF	CGA adapter
3F0-3F7	Floppy disk controller
3F8-3FF	Serial port-1

---

## 5-3 Time & DMA Channels Map

### Time map:

- Timer channel 0 system timer interrupt
- Timer channel 1 DRAM refresh request
- Timer channel 2 speaker tone generator

### Dma channels:

- DMA channel 0 available
- DMA channel 1 onboard ECP (option)
- DMA channel 2 floppy disk (ITE chip)
- DMA channel 3 onboard ECP (default)
- DMA channel 4 cascade for DMA controller 1
- DMA channel 5 available
- DMA channel 6 available
- DMA channel 7 available

---

## 5-4 Interrupt Map

A. **NMI:** non-maskable interrupt

B. **IRQ(H/W):**

- 0 system timer interrupt from timer 0
- 1. keyboard output buffer full
- 2. cascade for IRQ 8-15
- 3. serial port2
- 4. serial port1
- 5. parallel port 2
- 6. floppy disk (ITE chip)
- 7. parallel port 1
- 8. RTC clock
- 9. available
- 10. available
- 11. available
- 12. PS/2 mouse
- 13. math coprocessor
- 14. onboard hard disk (IDE1) channel
- 15. onboard hard disk (IDE2) channel

---

## 5-5 RTC & CMOS RAM Map

00	Seconds
01	Seconds Alarm
02	Minutes
03	Minutes Alarm
04	Hours
05	Hours Alarm
06	Day of Week
07	Day of Month
08	Month
09	Year
0A	Status Register A
0B	Status Register B
0C	Status Register C
0D	Status Register D
0E	Diagnostic Status Byte
0F	Shutdown Byte
10	Floppy Disk Type Drive Type Byte
12	Hard Disk Type Byte
13	Reserved
14	Equipment Type
15	Base Memory Low Byte
16	Base Memory High Byte
17	Extension Memory Low Byte
18	Extension Memory High Byte
19-2D	
2E-2F	
30	Reserved for Extension Memory Low Byte
31	Reserved for Extension Memory High Byte
33	Information Flag
34-3F	Reserved
40-7F	Reserved for Chipset Setting Data



---

## 5-6 Award BIOS Hard Disk Type

Type	Cylinder	Heads	Write Pre-comp	Landing Zone	Sectors	Size
1	306	4	128	305	17	10MB
2	615	4	300	615	17	21MB
3	615	6	300	615	17	32MB
4	940	8	512	940	17	65MB
5	940	6	512	940	17	49MB
6	615	4	65535	615	17	21MB
7	462	8	256	511	17	32MB
8	733	5	65535	733	17	31MB
9	900	15	65535	901	17	117MB
10	820	3	65535	820	17	21MB
11	855	5	65535	855	17	37MB
12	855	7	65535	855	17	52MB
13	306	8	128	319	17	21MB
14	733	7	65535	733	17	44MB
16	612	4	0	663	17	21MB
17	977	5	300	977	17	42MB
18	977	7	65535	977	17	59MB
19	1024	7	512	1023	17	62MB
20	733	5	300	732	17	31MB
21	733	7	300	732	17	44MB
22	733	5	300	733	17	31MB
23	306	4	0	336	17	10MB
24	977	5	0	925	17	42MB
25	1024	9	65535	925	17	80MB
26	1224	7	65535	754	17	74MB

---

Type	Cylinder	Heads	Write Pre-comp	Landing Zone	Sectors	Size
27	1224	11	65535	754	17	117MB
28	1224	15	65535	699	17	159MB
29	1024	8	65535	823	17	71MB
30	1024	11	65535	1023	17	98MB
31	918	11	65535	1023	17	87MB
32	925	9	65535	926	17	72MB
33	1024	10	65535	1023	17	89MB
34	1024	12	65535	1023	17	106MB
35	1024	13	65535	1023	17	115MB
36	1024	14	65535	1023	17	124MB
37	1024	2	65535	1023	17	17MB
38	1024	16	65535	1023	17	142MB
39	918	15	65535	1023	17	119MB
40	820	6	65535	820	17	42MB
41	1024	5	65535	1023	17	44MB
42	1024	8	65535	1023	17	68MB
43	809	6	65535	852	17	42MB
44	809	9	65535	852	17	64MB
45	776	8	65535	775	17	104MB
46	AUTO	0	0	0	0	
47	USER'S	TYPE				

---

## 5-7 ISA I/O Address Map

I/O Address (HEX)	I/O device
000 - 01F	DMA Controller 1, 8237A-5
020 - 03F	Interrupt Controller 1, 8259A
040 - 05F	System Timer, 8254-2
060 - 06F	8042 Keyboard Controller
070 - 07F	real-time Clock/CMOS and NMI Mask
080 - 09F	DMA Page Register, 74LS612
0A0 - 0BF	Interrupt Controller 2, 8259A
0C0 - 0DF	DMA Controller 2, 8237A-5
0F0 - 0FF	i486 Math Coprocessor
1F0 - 1F8	Fixed Disk Drive Adapter
200 - 207	Game I/O
20C - 20D	Reserved
21F	Reserved
278 - 27F	Parallel Printer Port 2
2B0 - 2DF	Alternate Enhanced Graphic Adapter
2E1	GPIB Adapter 0
2E2 - 2E3	Data Acquisition Adapter 0
2F8 - 2FF	Serial Port 2 (RS-232-C)
300 - 31F	Prototype Card
360 - 363	PC Network (Low Address)
364 - 367	Reserved
368 - 36B	PC Network (High Address)
36C - 36F	Reserved
378 - 37F	Parallel Printer Port 1

---

I/O Address (HEX)	I/O device
380 - 38F	SDLC, Bisynchronous 2
390 - 393	Cluster
3A0 - 3AF	Bisynchronous 1
3B0 - 3BF	Monochrome Display and Printer Adapter
3C0 - 3CF	Enhanced Graphics Adapter
3D0 - 3DF	Color/Graphics Monitor Adapter
3F0 - 3F7	Diskette Drive Controller
3F8 - 3FF	Serial Port 1 (RS-232-C)
6E2 - 6E3	Data Acquisition Adapter 1
790 - 793	Cluster Adapter 1
AE2 - AE3	Data Acquisition Adapter 2
B90 - B93	Cluster Adapter 2
EE2 - EE3	Data Acquisition Adapter 3
1390 - 1393	Cluster Adapter 3
22E1	GPIB Adapter 1
2390 - 2393	Cluster Adapter 4
42E1	GPIB Adapter 2
62E1	GPIB Adapter 3
82E1	GPIB Adapter 4
A2E1	GPIB Adapter 5
C2E1	GPIB Adapter 6
E2E1	GPIB Adapter 7

---

## Chapter 6 Q & A

### 6-1 Error Messages During Power on Self Test

During **power on self test (post)**, BIOS will automatically detect the system devices. Below are the questions that users most often ask. The user may press “**Esc**” key to skip the full memory test.

**1. *Beep sound***

While power on, the system makes beep sound to offer different messages. If the system is configured correctly, it prompts a short beep to show device configuration is done correctly. When VGA card and DIMM modules are not plugged well, the system makes longer and constant beep sounds.

**2. *BIOS ROM checksum error***

It indicates the checksum of the BIOS code is not right and system will always halt on power on screen. Contact the dealer to exchange a new BIOS.

**3. *CMOS battery fail***

It indicates the CMOS battery does not work. Contact the dealer to exchange a new battery.

**4. *CMOS checksum error***

It indicates the CMOS checksum is incorrect. Load the default values in BIOS to solve this problem. This error may result from weak BIOS, so replace new BIOS if necessary.

---

**5. *Hard disk initiation***

**Please wait a moment...**

Some hard drives require more time to initiate.

**6. *Hard disk install failure***

The system can not find or initiate the hard drive controller or the drive. Check if the controller is set correctly. If no hard disk is installed, "**Hard drive selection**" must be set to "**none.**"

**7. *Keyboard error or no keyboard present***

This means the system can not initialize the keyboard. Check if the keyboard is plugged well and be sure no keys are pressed during POST.

**8. *Keyboard is lock out - Unlock the key***

When this message comes out, check if there is anything mis-placed on the keyboard. Be sure nothing touches the keys.

**9. *Memory test fails***

There will be more information to specify the type and location of the memory error.

**10. *Primary master hard disk fail***

The BIOS finds an error in the primary master hard disk drive.

**11. *Primary slave hard disk fail***

The BIOS finds an error in the primary slave hard disk drive.

**12. *Secondary master hard disk fail***

The BIOS finds an error in the secondary slave master hard disk drive.

**13. *Secondary slave hard disk fail***

The BIOS finds an error in the secondary slave IDE hard disk drive.

