

1. Jumper Location Diagram for "B59 V1.X " Pentium main board

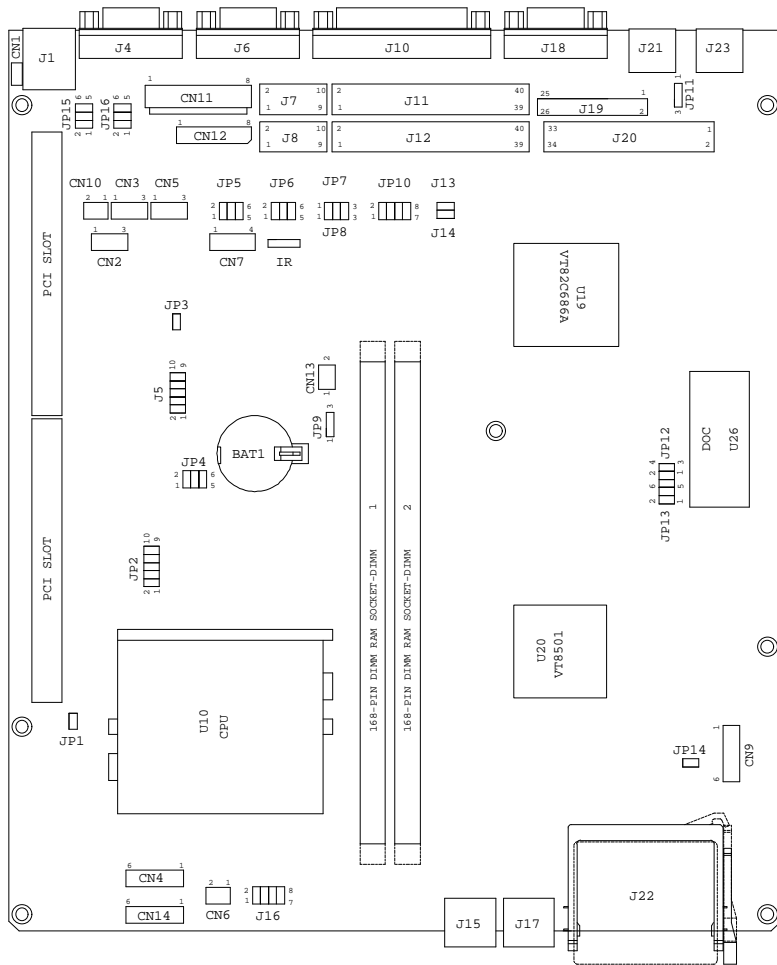

2. Memory configuration for “B59 V1.X” main board

- **System Memory Configuration**

Capacity	DIMM 1	DIMM 2
16MB	16MB	None
32MB	16MB	16MB
32MB	32MB	None
64MB	32MB	32MB
64MB	64MB	None
80MB	16MB	64MB
80MB	64MB	16MB
128MB	64MB	64MB
128MB	128MB	None
256MB	128MB	128MB

- **External Cache RAM Configuration.**

Capacity	SDRAM Type	Quantity	Location
256KB	32k x 64	1pcs	U15
512KB	64k x 64	1pcs	U15

3. Jumper Setting

In order to set up the correct configuration, here is the description about how to set the jumpers to enable/disable or change functions. All jumpers location please refer to jumper location diagram.

- **CPU type selection :J4, J10**

CPU	JP4			JP10			
	1-2	3-4	5-6	1-2	3-4	5-6	7-8
Pentium 100MHz	Open	Open	Open	Close	Open	Open	Open
Pentium 120MHz	Close	Open	Open	Open	Open	Open	Open
Pentium 133MHz	Close	Open	Open	Close	Open	Open	Open
Pentium 150MHz	Close	Close	Open	Open	Open	Open	Open
Pentium 166MHz	Close	Close	Open	Close	Open	Open	Open
IDT C6 180MHz	Open	Close	Open	Open	Open	Open	Open
IDT C6 200MHz	Open	Close	Open	Close	Open	Open	Open
Pentium 200MHz MMX	Open	Close	Open	Close	Open	Open	Open
Pentium 233MHz MMX	Open	Open	Open	Close	Open	Open	Open
AMD K6/233MHz(AFR)	Open	Open	Open	Close	Open	Open	Open
AMD K6/266MHz(AFR)	Close	Open	Close	Close	Open	Open	Open
AMD K6-2/266MHz							
AMD K6-2/300MHz	Open	Close	Open	Close	Close	Close	Open
AMD K6-2/350MHz	Open	Open	Open	Close	Close	Close	Open
AMD K6-2/400MHz	Close	Open	Close	Close	Close	Close	Open
AMD K6-3/400MHz							
AMD K6-3/450MHz	Close	Close	Close	Close	Close	Close	Open
AMD K6 -2/450MHZ							
AMD K6-2/500MHZ	Open	Close	Close	Close	Close	Close	Open
AMD-K6-3/500MHZ							

● **CPU Voltage selection :**

Vcore	JP2				
	1-2	3-4	5-6	7-8	9-10
1.5	Open	Open	Close	Open	Close
1.6	Open	Close	Close	Open	Close
1.7	Open	Open	Open	Close	Close
1.8	Open	Close	Open	Close	Close
1.9	Open	Open	Close	Close	Close
2.0	Open	Close	Close	Close	Close
2.1	Close	Open	Open	Open	Open
2.2	Open	Close	Open	Open	Open
2.3	Close	Close	Open	Open	Open
2.4	Open	Open	Close	Open	Open
2.5	Close	Open	Close	Open	open
2.6	Open	Close	Close	Open	Open
2.7	Close	Close	Close	Open	Open
2.8	Open	Open	Open	Close	Open
2.9	Close	Open	Open	Close	Open
3.0	Open	Close	Open	Close	Open
3.1	Close	Close	Open	Close	Open
3.2	Open	Open	Close	Close	Open
3.3	Close	Open	Close	Close	Open
3.4	Open	Close	Close	Close	Open
3.5	Close	Close	Close	Close	Open

● **CMOS data clean function : JP9**

CMOS data	JP9
Clean	2-3
Normal (default)	1-2

- **Disk On Chip address selection: JP12, JP13**

Address	JP12	JP13
0CC00H – 0CDDFFH	1-2	1-2
0D000H – 0D1FFH	1-2	3-4
0D400H – 0D5FFH	3-4	3-4
0D800H – 0D9FFH	1-2	5-6
0DC00H – 0DDFFH	3-4	5-6

- **RS232 Select Jumper :JP5,JP6,JP15,JP16**

RS232 Select	JP5,JP6,JP15,JP16
Normal (default)	1-2
RS232 pin1 use +5V	3-4
RS232 pin1 use +12V	5-6

● **Digital I/O (4 Output & 4 Input) : J5**

This main board provide the basic digital I/O signal controller, user can develop the program and extra controller to open and sense of the cash drawer based on the digital I/O function on this main board.

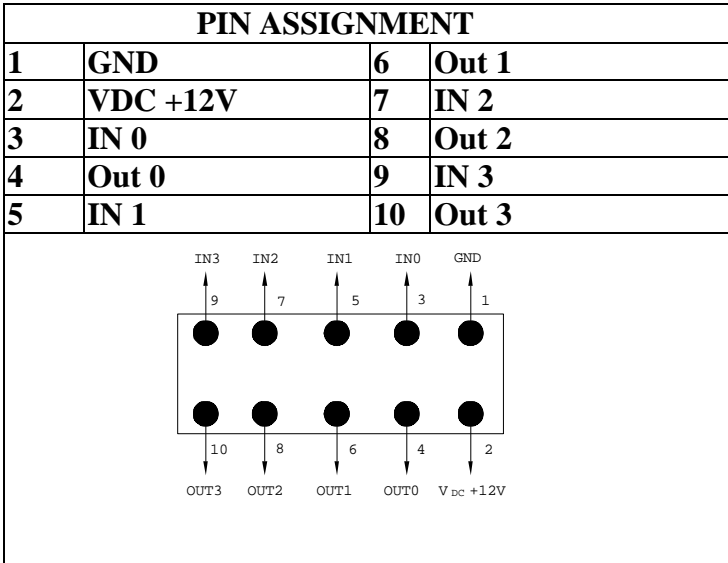

n Digital output programming

The output is TTL Level. The output signal must be TTL compatible.

Output	Address	Bit
Out 0	206	0
Out 1	206	1
Out 2	206	2
Out 3	206	3
Example : (“0” = off “1” =on)		
Data 00 = Out 0 and Out 1 = “0”		
Data 01 = Out 0 = “1”		
Data 02 = Out 1 = “1”		
Data 03 = Out 0 and Out 1 = “1”		

n Digital input programming

The input signal must be TTL compatible.

put	In	Address	Bit
IN 0		206	0
IN 1		206	1
IN 2		206	2
IN 3		206	3
Example : If input 206 is [0111], then input 3 is “0”, If input 206 is [0011], then input 3 & 4 are “0”			