

ThinkPad 380XD (2635)

ThinkPad 385XD (2635)

Hardware Maintenance Manual

May 1998

ThinkPad 380XD (2635)

ThinkPad 385XD (2635)

Hardware Maintenance Manual

May 1998



Note

Before using this information and the product it supports, be sure to read the general information under "Notices" on page 123.

First Edition (May 1998)

The following paragraph does not apply to the United Kingdom or any country where such provisions are inconsistent with local law:

INTERNATIONAL BUSINESS MACHINES CORPORATION PROVIDES THIS PUBLICATION "AS IS" WITHOUT ANY WARRANTY OF ANY KIND, EITHER EXPRESS OR IMPLIED, INCLUDING, BUT NOT LIMITED TO, THE LIMITED WARRANTIES OF MERCHANTABILITY OR FITNESS FOR A PARTICULAR PURPOSE. Some states do not allow disclaimer or express or implied warranties in certain transactions; therefore, this statement may not apply to you.

This publication could include technical inaccuracies or typographical errors. Changes are periodically made to the information herein; these changes will be incorporated in new editions of the publication. IBM may make improvements or changes to the products or the programs described in this publication at any time.

It is possible that this publication may contain references to, or information about, IBM products (machines and programs), programming, or services that are not announced in your country. Such references or information must not be construed to mean that IBM intends to announce such IBM products, programming, or services in your country.

Requests for technical information about IBM products should be made to your IBM authorized dealer or your IBM marketing representative.

© **Copyright International Business Machines Corporation 1998. All rights reserved.** Note to U.S. Government Users – Documentation related to restricted rights – Use, duplication, or disclosure is subject to restrictions set forth in GSA ADP Schedule Contract with IBM Corp.

About This Manual

This manual contains service and reference information for IBM ThinkPad 380XD, 385XD (2635) products. Use this manual along with the advanced diagnostic tests to troubleshoot problems effectively.

The manual is divided into sections as follows:

- The Introduction section provides general information, guidelines, and safety information required to service computers.
- The product-specific section includes service, reference, and product-specific parts information.

Important

This manual is intended for trained servicers who are familiar with ThinkPad products. Use this manual along with the advanced diagnostic tests to troubleshoot problems effectively.

Before servicing an IBM ThinkPad product, be sure to review the safety information under “Safety Notices (Multi-lingual Translations)” on page 5 and “Safety Information” on page 12.

Related Publications

The following product publications are available through IBM or your IBM Authorized Dealer.

Publication	Part, Form Number
Mobile Systems HMM Volume 1: Laptop, Notebook, Portable, and ThinkPad Computers (Models L40, CL57, N45, N51, P70/P75, ThinkPad 300, 350, 500, 510, 710T, Expansion Unit, Dock I, Dock II)	30H2356, S82G-1501-01
Mobile Systems HMM Volume 2: ThinkPad Computers (Models 340, 355, 360, 370, 700, 701, 720, 750, 755)	30H2357, S82G-1502-03
Mobile Systems HMM Volume 3: ThinkPad Computers (Models 365, 380, 385, 560, 760, SelectaDock)	84H8099, S82G-1503-05
Mobile Systems HMM Volume 4: ThinkPad Computers (Models 380, 385, 560, 760, 765)	05L1271, S05L-1270-01

Related Diskettes

The following diskettes are available through IBM or your IBM Authorized Dealer.

Diskette	Part, Form Number
ThinkPad 300 (2615) Advanced Diagnostics Diskette	33G9361, S33G-9361
ThinkPad 350, 350C, 425, 425C (2618) Advanced Diagnostics Diskette	A211000, GA21-1000
ThinkPad 365 (2625) Advanced Diagnostics Diskette	76H7578, S30H-2498
ThinkPad 380/385 (2635) Maintenance Diskette	06J0333, S06J-0333
ThinkPad 500 (2603) Advanced Diagnostics Diskette	71G3702, S71G-3702
ThinkPad 510 (2604) Advanced Diagnostics Diskette	83G8095, S83G-8095
ThinkPad 700 (9552) Reference Diskette	42G2017, S42G-2017
ThinkPad 700C (9552) Reference Diskette	42G2023, S42G-2023
ThinkPad 720/720C (9552) Reference Diskette	61G1194, S61G-1194
ThinkPad Hardware Maintenance Diskette (for all Models 355, 360, 560, 750, 755, 760)	78H5384, S78H-5384
ThinkPad Dock I (3545)	71G4140, S71G-4140
Docking Station (3550)	42G2428, S42G-2428
Data/Fax Modem	61G1556, S61G-1556
FaxConcentrator/A	84F8540, S84F-8540

IBM ThinkPad 380XD, 385XD (2635)

Introduction	3
How to Use Error Messages	4
How to Read POST Error Messages	4
Safety Notices (Multi-lingual Translations)	5
Safety Information	12
General Safety	12
Electrical Safety	13
Safety Inspection Guide	14
Handling Electrostatic Discharge-Sensitive Devices	16
Grounding Requirements	16
Laser Compliance Statement	17
Read This First	19
Product Overview	23
Checkout Guide	25
Audio Checkout	26
Diskette Drive Checkout	26
Fan Checkout	27
Keyboard or Auxiliary Input Device Checkout	27
Memory Checkout	28
Power Systems Checkout	29
Status Indicator Checkout	32
System Board and CPU Card Checkout	32
TrackPoint III Checkout	32
Optional Device Checkout	33
Port Replicator Checkout	33
External Monitor Self-Test	34
Power Management Features	35
Symptom-to-FRU Index	38
Numeric Error Codes	38
Beep Symptoms	43
Function-Related Symptoms	44
Indicator-Related Symptoms	44
Infrared-Related Symptoms	45
Keyboard- or TrackPoint III-Related Symptoms	45
LCD-Related Symptoms	46
Peripheral-Device-Related Symptoms	46
Power-Related Symptoms	47
Other Symptoms	47
Intermittent Problems	47
Undetermined Problems	48
Running the Diagnostics	49
PC Card (PCMCIA) Slots Test	50
Universal Serial Bus (USB) Test	50
Displaying the Error Log	50
Checking the Installed Devices List	50
Diagnostic Error Codes	52
Related Service Procedures	55
Status Indicators	55
Password Combinations	56
Running a Low-Level Format	57
Maintenance Diskette Download	57

Fn Key Combinations	57
FRU Removals and Replacements	58
Important Notice	59
FRU Service Procedure	60
Removal Reference	61
1010 DIMM Card and Backup Battery	62
1020 Battery Pack	63
1030 Hard Disk Drive	64
1040 Keyboard Unit	66
1050 Keyboard and Speaker	69
1060 CD-ROM Drive and Diskette Drive Assembly	71
1070 Diskette Drive and CD-ROM Drive	72
1080 LCD Unit	76
1090 Fan Assembly, CPU Card, Thermal Rubber	79
1100 Upper Shield Case	82
1110 Box Speaker and Microphone	83
1120 DC/DC Card	85
1130 System Board and PC Card Slot	87
1140 Battery Pack Latch	90
2010 LCD Front Cover	91
2020 LCD Panel	93
2030 LCD Inverter Card	97
2040 LCD Misc. Parts	99
2050 LCD Cable	103
Locations	104
Front View	104
Bottom View	105
Rear View	106
Parts Listing	107
System Unit	108
Hard Disk Drive, CD-ROM, Diskette Drive	110
LCD FRU	111
Option Parts List	118
Notices	123
Trademarks	123

Introduction

Important

Diskette fixes are customer installable. The diskette fixes are located on the PC Company Bulletin Board Service (BBS). The direct phone line for modem connection is 919-557-0001 or tieline 255-0001.

Advise customers to contact the PC Company HelpCenter at 800-772-2227 if they need assistance in obtaining or installing any diskette fixes.

Customers in Canada should call IBM HelpPC at 800-565-3344 for assistance or down-load information. The Canadian BBS phone numbers are:

Montreal	514-938-3022
Toronto	905-316-4255
Vancouver	604-664-6464
Winnipeg	204-934-2735

FRU Replacement Strategy

Ensure that all diskette fixes are installed prior to replacing any FRUs. And, use the following strategy to prevent unnecessary FRU replacement and service expense:

- **If you are instructed to replace a FRU and that does not correct the problem, reinstall the original FRU before you continue.**
- Some computers have both a processor board and a system board. If you are instructed to replace either the processor board or the system board, and the first board that you replaced does not correct the problem, reinstall the original board, then replace the other (processor or system) board.
- If an adapter or device consists of more than one FRU, an error code may be caused by any of the FRUs. Before replacing the adapter or device, remove the FRUs, one by one, to see if the symptoms change. Replace only the FRU that changed the symptoms.

Attention

A customized setup configuration (other than default settings) may exist on the computer you are servicing. Running Automatic Configuration may alter those settings. Note the current configuration settings (using the View Configuration option) and verify that the settings are in place when service is complete.

The advanced diagnostic tests are intended to test *only* IBM products. Non-IBM products or modified options can give false errors and invalid responses.

Hard Disk Drive Replacement Strategy:

Always try to run a low-level format before replacing a hard disk drive.

Attention

The drive startup sequence in the computer you are servicing might have been changed. Be extremely careful during write operations such as copying, saving, or formatting. Data or programs can be overwritten if you select an incorrect drive.

How to Use Error Messages

Use the error codes displayed on the screen to diagnose failures. If more than one error code is displayed, begin the diagnosis with the first error code. The cause of the first error code can result in false error codes being displayed. If no error code is displayed, see if the error symptom is listed in the Symptom-to-FRU Index for the computer you are servicing.

How to Read POST Error Messages

POST error messages are displayed on the screen as three, four, five, or eight digits. The error messages that can be displayed as shorter POST messages are highlighted in this index. Some digits will represent different information for SCSI errors versus non-SCSI errors.

The following example shows which digits display the shorter POST error messages and also defines the SCSI information in an eight-digit error message.

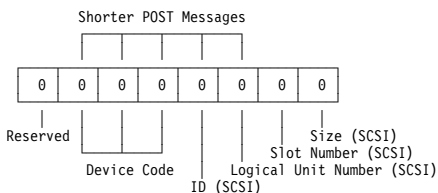

All SCSI devices are set to a different SCSI ID.

Duplicate SCSI ID settings can generate a false error message. Use the SCSI ID to determine whether the error message is coming from an internal or an external device.

Safety Notices (Multi-lingual Translations)

In this manual, safety notices appear in English with a page number reference to the appropriate multi-lingual, translated safety notice found in this section.

The following safety notices are provided in English, French, German, Italian, and Spanish languages.

Safety Notice 1

Before the computer is powered-on after FRU replacement, make sure all screws, springs, or other small parts are in place and are not left loose inside the computer. Verify this by shaking the computer and listening for rattling sounds. Metallic parts or metal flakes can cause electrical shorts.

Avant de remettre l'ordinateur sous tension après remplacement d'une unité en clientèle, vérifiez que tous les ressorts, vis et autres pièces sont bien en place et bien fixées. Pour ce faire, secouez l'unité et assurez-vous qu'aucun bruit suspect ne se produit. Des pièces métalliques ou des copeaux de métal pourraient causer un court-circuit.

Bevor nach einem FRU-Austausch der Computer wieder angeschlossen wird, muß sichergestellt werden, daß keine Schrauben, Federn oder andere Kleinteile fehlen oder im Gehäuse vergessen wurden. Der Computer muß geschüttelt und auf Klappergeräusche geprüft werden. Metallteile oder -splitter können Kurzschlüsse erzeugen.

Prima di accendere l'elaboratore dopo che é stata effettuata la sostituzione di una FRU, accertarsi che tutte le viti, le molle e tutte le altri parti di piccole dimensioni siano nella corretta posizione e non siano sparse all'interno dell'elaboratore. Verificare ciò scuotendo l'elaboratore e prestando attenzione ad eventuali rumori; eventuali parti o pezzetti metallici possono provocare cortocircuiti pericolosi.

Antes de encender el sistema despues de sustituir una FRU, compruebe que todos los tornillos, muelles y demás piezas pequeñas se encuentran en su sitio y no se encuentran sueltas dentro del sistema. Compruébelo agitando el sistema y escuchando los posibles ruidos que provocarían. Las piezas metálicas pueden causar cortocircuitos eléctricos.

Safety Notice 2

Some standby batteries contain a small amount of nickel and cadmium. Do not disassemble it, recharge it, throw it into fire or water, or short-circuit it. Dispose of the battery as required by local ordinances or regulations. Use only the battery in the appropriate parts listing. Use of an incorrect battery can result in ignition or explosion of the battery.

Certaines batteries de secours contiennent du nickel et du cadmium. Ne les démontez pas, ne les rechargez pas, ne les exposez ni au feu ni à l'eau. Ne les mettez pas en court-circuit. Pour les mettre au rebut, conformez-vous à la réglementation en vigueur. Lorsque vous remplacez la pile de sauvegarde ou celle de l'horloge temps réel, veillez à n'utiliser que les modèles cités dans la liste de pièces détachées adéquate. Une batterie ou une pile inappropriée risque de prendre feu ou d'exploser.

Die Bereitschaftsbatterie, die sich unter dem Diskettenlaufwerk befindet, kann geringe Mengen Nickel und Cadmium enthalten. Sie darf nur durch die Verkaufsstelle oder den IBM Kundendienst ausgetauscht werden. Sie darf nicht zerlegt, wiederaufgeladen, kurzgeschlossen, oder Feuer oder Wasser ausgesetzt werden. Die Batterie kann schwere Verbrennungen oder Verätzungen verursachen. Bei der Entsorgung die örtlichen Bestimmungen für Sondermüll beachten. Beim Ersetzen der Bereitschafts- oder Systembatterie nur Batterien des Typs verwenden, der in der Ersatzteilliste aufgeführt ist. Der Einsatz falscher Batterien kann zu Entzündung oder Explosion führen.

Alcune batterie di riserva contengono una piccola quantità di nichel e cadmio. Non smontarle, ricaricarle, gettarle nel fuoco o nell'acqua né cortocircuitarle. Smaltirle secondo la normativa in vigore (DPR 915/82, successive disposizioni e disposizioni locali). Quando si sostituisce la batteria dell'RTC (real time clock) o la batteria di supporto, utilizzare soltanto i tipi inseriti nell'appropriato Catalogo parti. L'impiego di una batteria non adatta potrebbe determinare l'incendio o l'esplosione della batteria stessa.

Algunas baterías de reserva contienen una pequeña cantidad de níquel y cadmio. No las desmonte, ni recargue, ni las eche al fuego o al agua ni las cortocircuite. Deséchelas tal como dispone la normativa local. Utilice sólo baterías que se encuentren en la lista de piezas. La utilización de una batería no apropiada puede provocar la ignición o explosión de la misma.

Safety Notice 3

The battery pack contains small amounts of nickel. Do not disassemble it, throw it into fire or water, or short-circuit it. Dispose of the battery pack as required by local ordinances or regulations. Use only the battery in the appropriate parts listing when replacing the battery pack. Use of an incorrect battery can result in ignition or explosion of the battery.

La batterie contient du nickel. Ne la démontez pas, ne l'exposez ni au feu ni à l'eau. Ne la mettez pas en court-circuit. Pour la mettre au rebut, conformez-vous à la réglementation en vigueur. Lorsque vous remplacez la batterie, veillez à n'utiliser que les modèles cités dans la liste de pièces détachées adéquate. En effet, une batterie inappropriée risque de prendre feu ou d'exploser.

Akkus enthalten geringe Mengen von Nickel. Sie dürfen nicht zerlegt, wiederaufgeladen, kurzgeschlossen, oder Feuer oder Wasser ausgesetzt werden. Bei der Entsorgung die örtlichen Bestimmungen für Sondermüll beachten. Beim Ersetzen der Batterie nur Batterien des Typs verwenden, der in der Ersatzteilliste aufgeführt ist. Der Einsatz falscher Batterien kann zu Entzündung oder Explosion führen.

La batteria contiene piccole quantità di nichel. Non smontarla, gettarla nel fuoco o nell'acqua né cortocircuitarla. Smaltirla secondo la normativa in vigore (DPR 915/82, successive disposizioni e disposizioni locali). Quando si sostituisce la batteria, utilizzare soltanto i tipi inseriti nell'appropriato Catalogo parti. L'impiego di una batteria non adatta potrebbe determinare l'incendio o l'esplosione della batteria stessa.

Las baterías contienen pequeñas cantidades de níquel. No las desmonte, ni recargue, ni las eche al fuego o al agua ni las cortocircuite. Deséchelas tal como dispone la normativa local. Utilice sólo baterías que se encuentren en la lista de piezas al sustituir la batería. La utilización de una batería no apropiada puede provocar la ignición o explosión de la misma.

Safety Notice 4

The lithium battery can cause a fire, explosion, or severe burn. Do not recharge it, remove its polarized connector, disassemble it, heat it above 100°C (212°F), incinerate it, or expose its cell contents to water. Dispose of the battery as required by local ordinances or regulations. Use only the battery in the appropriate parts listing. Use of an incorrect battery can result in ignition or explosion of the battery.

La pile de sauvegarde contient du lithium. Elle présente des risques d'incendie, d'explosion ou de brûlures graves. Ne la rechargez pas, ne retirez pas son connecteur polarisé et ne la démontez pas. Ne l'exposez pas à une température supérieure à 100°C, ne la faites pas brûler et n'en exposez pas le contenu à l'eau. Mettez la pile au rebut conformément à la réglementation en vigueur. Une pile inappropriée risque de prendre feu ou d'exploser.

Die Systematterie ist eine Lithiumatterie. Sie kann sich entzünden, explodieren oder schwere Verbrennungen hervorrufen. Batterien dieses Typs dürfen nicht aufgeladen, zerlegt, über 100 C erhitzt oder verbrannt werden. Auch darf ihr Inhalt nicht mit Wasser in Verbindung gebracht oder der zur richtigen Polung angebrachte Verbindungsstecker entfernt werden. Bei der Entsorgung die örtlichen Bestimmungen für Sondermüll beachten. Beim Ersetzen der Batterie nur Batterien des Typs verwenden, der in der Ersatzteilliste aufgeführt ist. Der Einsatz falscher Batterien kann zu Entzündung oder Explosion führen.

La batteria di supporto è una batteria al litio e può incendiarsi, esplodere o procurare gravi ustioni. Evitare di ricaricarla, smontarne il connettore polarizzato, smontarla, riscaldarla ad una temperatura superiore ai 100 gradi centigradi, incendiarla o gettarla in acqua. Smaltirla secondo la normativa in vigore (DPR 915/82, successive disposizioni e disposizioni locali). L'impiego di una batteria non adatta potrebbe determinare l'incendio o l'esplosione della batteria stessa.

La batería de repuesto es una batería de litio y puede provocar incendios, explosiones o quemaduras graves. No la recargue, ni quite el conector polarizado, ni la desmonte, ni caliente por encima de los 100°C (212°F), ni la incinere ni exponga el contenido de sus celdas al agua. Deséchela tal como dispone la normativa local.

Safety Notice 5

If the LCD breaks and the fluid from inside the LCD gets into your eyes or on your hands, immediately wash the affected areas with water for at least 15 minutes. Seek medical care if any symptoms from the fluid are present after washing.

Si le panneau d'affichage à cristaux liquides se brise et que vous recevez dans les yeux ou sur les mains une partie du fluide, rincez-les abondamment pendant au moins quinze minutes. Consultez un médecin si des symptômes persistent après le lavage.

Die Leuchtstoffröhre im LCD-Bildschirm enthält Quecksilber. Bei der Entsorgung die örtlichen Bestimmungen für Sondermüll beachten. Der LCD-Bildschirm besteht aus Glas und kann zerbrechen, wenn er unsachgemäß behandelt wird oder der Computer auf den Boden fällt. Wenn der Bildschirm beschädigt ist und die darin befindliche Flüssigkeit in Kontakt mit Haut und Augen gerät, sollten die betroffenen Stellen mindestens 15 Minuten mit Wasser abgespült und bei Beschwerden anschließend ein Arzt aufgesucht werden.

Nel caso che caso l'LCD si dovesse rompere ed il liquido in esso contenuto entrasse in contatto con gli occhi o le mani, lavare immediatamente le parti interessate con acqua corrente per almeno 15 minuti; poi consultare un medico se i sintomi dovessero permanere.

Si la LCD se rompe y el fluido de su interior entra en contacto con sus ojos o sus manos, lave inmediatamente las áreas afectadas con agua durante 15 minutos como mínimo. Obtenga atención medica si se presenta algún síntoma del fluido despues de lavarse.

Safety Notice 6

To avoid shock, do not remove the plastic cover that surrounds the lower portion of the inverter card.

Afin d'éviter tout risque de choc électrique, ne retirez pas le cache en plastique protégeant la partie inférieure de la carte d'alimentation.

Aus Sicherheitsgründen die Kunststoffabdeckung, die den unteren Teil der Spannungswandlerplatine umgibt, nicht entfernen.

Per evitare scosse elettriche, non rimuovere la copertura in plastica che avvolge la parte inferiore della scheda invertitore.

Para evitar descargas, no quite la cubierta de plástico que rodea la parte baja de la tarjeta invertida.

Safety Notice 7

Though main batteries have low voltage, a shorted or grounded battery can produce enough current to burn combustible materials or personnel.

Bien que le voltage des batteries principales soit peu élevé, le court-circuit ou la mise à la masse d'une batterie peut produire suffisamment de courant pour brûler des matériaux combustibles ou causer des brûlures corporelles graves.

Obwohl Hauptbatterien eine niedrige Spannung haben, können sie doch bei Kurzschluß oder Erdung genug Strom abgeben, um brennbare Materialien zu entzünden oder Verletzungen bei Personen hervorzurufen.

Sebbene le batterie di alimentazione siano a basso voltaggio, una batteria in corto circuito o a massa può fornire corrente sufficiente da bruciare materiali combustibili o provocare ustioni ai tecnici di manutenzione.

Aunque las baterías principales tienen un voltaje bajo, una batería cortocircuitada o con contacto a tierra puede producir la corriente suficiente como para quemar material combustible o provocar quemaduras en el personal.

Safety Notice 8

Before removing any FRU, power-off the computer, unplug all power cords from electrical outlets, remove the battery pack, then disconnect any interconnecting cables.

Avant de retirer une unité remplaçable en clientèle, mettez le système hors tension, débranchez tous les cordons d'alimentation des socles de prise de courant, retirez la batterie et déconnectez tous les cordons d'interface.

Die Stromzufuhr muß abgeschaltet, alle Stromkabel aus der Steckdose gezogen, der Akku entfernt und alle Verbindungskabel abgenommen sein, bevor eine FRU entfernt wird.

Prima di rimuovere qualsiasi FRU, spegnere il sistema, scollegare dalle prese elettriche tutti i cavi di alimentazione, rimuovere la batteria e poi scollegare i cavi di interconnessione.

Antes de quitar una FRU, apague el sistema, desenchufe todos los cables de las tomas de corriente eléctrica, quite la batería y, a continuación, desconecte cualquier cable de conexión entre dispositivos.

Safety Information

The following section contains the safety information that you need to be familiar with before servicing an IBM mobile computer.

General Safety

Follow these rules to ensure general safety:

- Observe good housekeeping in the area of the machines during and after maintenance.
- When lifting any heavy object:
 1. Ensure you can stand safely without slipping.
 2. Distribute the weight of the object equally between your feet.
 3. Use a slow lifting force. Never move suddenly or twist when you attempt to lift.
 4. Lift by standing or by pushing up with your leg muscles; this action removes the strain from the muscles in your back. *Do not attempt to lift any objects that weigh more than 16 kg (35 lb) or objects that you think are too heavy for you.*
- Do not perform any action that causes hazards to the customer, or that makes the equipment unsafe.
- Before you start the machine, ensure that other service representatives and the customer's personnel are not in a hazardous position.
- Place removed covers and other parts in a safe place, away from all personnel, while you are servicing the machine.
- Keep your tool case away from walk areas so that other people will not trip over it.
- Do not wear loose clothing that can be trapped in the moving parts of a machine. Ensure that your sleeves are fastened or rolled up above your elbows. If your hair is long, fasten it.
- Insert the ends of your necktie or scarf inside clothing or fasten it with a nonconductive clip, approximately 8 centimeters (3 inches) from the end.
- Do not wear jewelry, chains, metal-frame eyeglasses, or metal fasteners for your clothing.

Attention: Metal objects are good electrical conductors.

- Wear safety glasses when you are: hammering, drilling soldering, cutting wire, attaching springs, using solvents, or working in any other conditions that might be hazardous to your eyes.
- After service, reinstall all safety shields, guards, labels, and ground wires. Replace any safety device that is worn or defective.
- Reinstall all covers correctly before returning the machine to the customer.

Electrical Safety

Observe the following rules when working on electrical equipment.

Important

Use only approved tools and test equipment. Some hand tools have handles covered with a soft material that does not insulate you when working with live electrical currents.

Many customers have, near their equipment, rubber floor mats that contain small conductive fibers to decrease electrostatic discharges. Do not use this type of mat to protect yourself from electrical shock.

- Find the room emergency power-off (EPO) switch, disconnecting switch, or electrical outlet. If an electrical accident occurs, you can then operate the switch or unplug the power cord quickly.
- Do not work alone under hazardous conditions or near equipment that has hazardous voltages.
- Disconnect all power before:
 - Performing a mechanical inspection
 - Working near power supplies
 - Removing or installing main units
- Before you start to work on the machine, unplug the power cord. If you cannot unplug it, ask the customer to power-off the wall box that supplies power to the machine and to lock the wall box in the off position.
- If you need to work on a machine that has *exposed* electrical circuits, observe the following precautions:
 - Ensure that another person, familiar with the power-off controls, is near you.

Attention: Another person must be there to switch off the power, if necessary.
 - Use only one hand when working with powered-on electrical equipment; keep the other hand in your pocket or behind your back.

Attention: There must be a complete circuit to cause electrical shock. By observing the above rule, you may prevent a current from passing through your body.
 - When using testers, set the controls correctly and use the approved probe leads and accessories for that tester.
 - Stand on suitable rubber mats (obtained locally, if necessary) to insulate you from grounds such as metal floor strips and machine frames.

Observe the special safety precautions when you work with very high voltages; these instructions are in the safety sections of maintenance information. Use extreme care when measuring high voltages.

- Regularly inspect and maintain your electrical hand tools for safe operational condition.
- Do not use worn or broken tools and testers.
- *Never assume* that power has been disconnected from a circuit. First, *check* that it has been powered-off.
- Always look carefully for possible hazards in your work area. Examples of these hazards are moist floors, nongrounded power extension cables, power surges, and missing safety grounds.
- Do not touch live electrical circuits with the reflective surface of a plastic dental mirror. The surface is conductive; such touching can cause personal injury and machine damage.
- Do not service the following parts *with the power on* when they are removed from their normal operating places in a machine:
 - Power supply units
 - Pumps
 - Blowers and fans
 - Motor generators

and similar units. (This practice ensures correct grounding of the units.)

- If an electrical accident occurs:
 - **Use caution; do not become a victim yourself.**
 - **Switch off power.**
 - **Send another person to get medical aid.**

Safety Inspection Guide

The intent of this inspection guide is to assist you in identifying potentially unsafe conditions on these products. Each machine, as it was designed and built, had required safety items installed to protect users and service personnel from injury. This guide addresses only those items. However, good judgment should be used to identify potential safety hazards due to attachment of non-IBM features or options not covered by this inspection guide.

If any unsafe conditions are present, you must determine how serious the apparent hazard could be and whether you can continue without first correcting the problem.

Consider these conditions and the safety hazards they present:

- Electrical hazards, especially primary power (primary voltage on the frame can cause serious or fatal electrical shock).
- Explosive hazards, such as a damaged CRT face or bulging capacitor
- Mechanical hazards, such as loose or missing hardware

The guide consists of a series of steps presented in a checklist. Begin the checks with the power off, and the power cord disconnected.

Checklist:

1. Check exterior covers for damage (loose, broken, or sharp edges).
2. Power-off the computer. Disconnect the power cord.
3. Check the power cord for:
 - a. A third-wire ground connector in good condition. Use a meter to measure third-wire ground continuity for 0.1 ohm or less between the external ground pin and frame ground.
 - b. The power cord should be the appropriate type as specified in the parts listings.
 - c. Insulation must not be frayed or worn.
4. Remove the cover.
5. Check for any obvious non-IBM alterations. Use good judgment as to the safety of any non-IBM alterations.
6. Check inside the unit for any obvious unsafe conditions, such as metal filings, contamination, water or other liquids, or signs of fire or smoke damage.
7. Check for worn, frayed, or pinched cables.
8. Check that the power-supply cover fasteners (screws or rivets) have not been removed or tampered with.

Handling Electrostatic Discharge-Sensitive Devices

Any computer part containing transistors or integrated circuits (ICs) should be considered sensitive to electrostatic discharge (ESD). ESD damage can occur when there is a difference in charge between objects. Protect against ESD damage by equalizing the charge so that the machine, the part, the work mat, and the person handling the part are all at the same charge.

Notes

1. Use product-specific ESD procedures when they exceed the requirements noted here.
2. Make sure that the ESD protective devices you use have been certified (ISO 9000) as fully effective.

When handling ESD-sensitive parts:

- Keep the parts in protective packages until they are inserted into the product.
- Avoid contact with other people.
- Wear a grounded wrist strap against your skin to eliminate static on your body.
- Prevent the part from touching your clothing. Most clothing is insulative and retains a charge even when you are wearing a wrist strap.
- Use the black side of a grounded work mat to provide a static-free work surface. The mat is especially useful when handling ESD-sensitive devices.
- Select a grounding system, such as those listed below, to provide protection that meets the specific service requirement.

Note

The use of a grounding system is desirable but not required to protect against ESD damage.

- Attach the ESD ground clip to any frame ground, ground braid, or green-wire ground.
- Use an ESD common ground or reference point when working on a double-insulated or battery-operated system. You can use coax or connector-outside shells on these systems.
- Use the round ground-prong of the AC plug on AC-operated computers.

Grounding Requirements

Electrical grounding of the computer is required for operator safety and correct system function. Proper grounding of the electrical outlet can be verified by a certified electrician.

Laser Compliance Statement

Some IBM Personal Computer models are equipped from the factory with a CD-ROM drive. CD-ROM drives are also sold separately as options. The CD-ROM drive is a laser product. The CD-ROM drive is certified in the U.S. to conform to the requirements of the Department of Health and Human Services 21 Code of Federal Regulations (DHHS 21 CFR) Subchapter J for Class 1 laser products. Elsewhere, the drive is certified to conform to the requirements of the International Electrotechnical Commission (IEC) 825 and CENELEC EN 60 825 for Class 1 laser products.

When a CD-ROM drive is installed, note the following.



CAUTION:

Use of controls or adjustments or performance of procedures other than those specified herein might result in hazardous radiation exposure.

O uso de controles, ajustes ou desempenho de procedimentos diferentes daqueles aqui especificados pode resultar em perigosa exposição à radiação.

凡未在这里指明的任何控制用法、调整、行为，都会导致严重后果。

Pour éviter tout risque d'exposition au rayon laser, respectez les consignes de réglage et d'utilisation des commandes, ainsi que les procédures décrites.

Werden Steuer- und Einstellelemente anders als hier festgesetzt verwendet, kann gefährliche Laserstrahlung auftreten.

Az itt előírt eljárásoktól, beállításoktól és vezérlésektől eltérni a lézersugárzás veszélye miatt kockázatos !

L'utilizzo di controlli, regolazioni o l'esecuzione di procedure diverse da quelle specificate possono provocare l'esposizione a

Использование элементов настройки и выполнение процедур иных, чем указано здесь, может привести к опасному радиационному облучению.

Použitie kontrol, úprav alebo iných vykonaní od iných výrobcov, ako je v tomto špecifikované, mohlo by mať za následok nebezpečenstvo vystavenia sa vyžiarovaniu.

El uso de controles o ajustes o la ejecución de procedimientos distintos de los aquí especificados puede provocar la exposición a radiaciones peligrosas.

Opening the CD-ROM drive could result in exposure to hazardous laser radiation. There are no serviceable parts inside the CD-ROM drive. **Do not open.**

Some CD-ROM drives contain an embedded Class 3A or Class 3B laser diode. Note the following.

DANGER:

Laser radiation when open. Do not stare into the beam, do not view directly with optical instruments, and avoid direct exposure to the beam.

Radiação por raio laser ao abrir. Não olhe fixo no feixe de luz, não olhe diretamente por meio de instrumentos óticos e evite exposição direta com o feixe de luz.

开启时会有激光发射时，请勿盯视激光光束，请勿直接查看视觉仪器，并且避免直接接触在激光光束之中。

Rayonnement laser si carter ouvert. Évitez de fixer le faisceau, de le regarder directement avec des instruments optiques, ou de vous exposer au rayon.

Laserstrahlung bei geöffnetem Gerät. Nicht direkt oder über optische Instrumente in den Laserstrahl sehen und den Strahlungsbereich meiden.

Kinyitáskor lézersugár ! Ne nézzen bele se szabad szemmel, se optikai eszközökkel. Kerülje a sugárnyalábbal való érintkezést !

Aprendo l'unità vengono emesse radiazioni laser. Non fissare il fascio, non guardarlo direttamente con strumenti ottici e evitare l'esposizione diretta al fascio.

Открывая, берегитесь лазерного излучения. Не смотрите на луч, не разглядывайте его с помощью оптических инструментов, а также избегайте прямого воздействия лазерного луча.

Keď je laserová jednotka otvorená. Vyhnite sa priamemu pohľadu a neľadte priamo s optickými nástrojmi do lúča a vyhnite sa priamemu vystaveniu lúčov.

Radiación láser al abrir. No mire fijamente ni examine con instrumental óptico el haz de luz. Evite la exposición directa al haz.

Read This First

Before you go to the checkout guide, be sure to read this section.

Important Notes

- **Only certified trained personnel should service the computer.**
- Read FRU service procedures before replacing any FRUs.
- **Be extremely careful during write operations such as copying, saving, or formatting.**
Drives in the computer that you are servicing might have been rearranged or the drive start-up sequence might have been altered. If you select an incorrect drive, data or programs can be overwritten.
- **Replace FRUs only for the correct model.**
When you replace the FRU, make sure the model of the machine and FRU part number are correct by referring to the parts list.
- **FRUs should not be replaced because of a single, unreproducible failure.** Single failures can occur from a variety of reasons that have nothing to do with a hardware problem, such as cosmic radiation, electrostatic discharge, or software errors. FRU replacement should be considered only when a recurring problem exists. If this is suspected, clear the error log and run the test again. Do not replace any FRUs if log errors do not reappear.
- **Be careful not to replace a nondefective FRU.**

How to Use Error Messages: Use the error codes displayed on the screen to diagnose failures. If more than one error code is displayed, begin the diagnosis with the first error code. The cause of the first error code can result in false error codes being displayed. If no error code is displayed, see if the error symptom is listed in the “Symptom-to-FRU Index” on page 38.

Port Replicator Problems: If you suspect a problem with the Port Replicator, see “Port Replicator Checkout” on page 33.

How to Diagnose Multiple FRUs: When the adapter or device has more than one FRU, the error code could be caused by either FRU. Before replacing multiple FRUs, try removing or exchanging each FRU, one by one in the designated sequence, to see if the symptoms change.

What to Do First: The service personnel must fill in the following information in the parts exchange form or parts return form that is attached to the returned FRU:

- ___ 1. Name and phone number of service personnel
- ___ 2. Date of service
- ___ 3. Date when the part failed
- ___ 4. Date of purchase
- ___ 5. Failure symptoms, error codes appearing on the monitor, and beep symptoms
- ___ 6. Procedure index and page number in which the failing FRU was detected
- ___ 7. Failing FRU name and the part number
- ___ 8. Machine type, model number, and serial number
- ___ 9. Customer's name and address

Before checking problems with the computer, determine whether the damage is covered under the warranty by referring to the following:

Warranty Note: During the warranty period, the customer may be responsible for repair costs if the computer damage was caused by misuse, accident, modification, unsuitable physical or operating environment, or improper maintenance by the customer. The following list provides some common items that are not covered under warranty and some symptoms that may indicate the system was subjected to stresses beyond normal use:

The following is not covered under warranty:

- LCD panel cracked by applying excessive force or by being dropped
- Scratched (cosmetic) parts
- Cracked or broken plastic parts, broken latches, broken pins, or broken connectors caused by excessive force
- Damage caused by liquid spilled into the system
- Damage caused by improperly inserting a PC card or installation of an incompatible card
- Damage caused by any foreign material in the FDD
- Diskette drive damage caused by pressing the diskette drive cover or inserting diskettes with multiple labels
- Damaged or bent diskette eject button
- CD-ROM drive damage caused by shock from excessive force, or by being dropped
- Fuses blown by attaching a nonsupported device
- Forgotten computer password (making the computer unusable)

The following symptoms might indicate damage caused by nonwarranted activities:

- Missing parts may be a symptom of unauthorized service or modification.
- HDD spindles can become noisy from being subjected to excessive force or from being dropped.
- I9990303 errors can be caused by exposure to strong magnetic fields.

Disabling the Power-On Password:

- **When only the power-on password is installed.**
 1. Turn off the computer.
 2. Turn the computer upside down, loosen the memory-slot cover screw **1**, and remove the memory-slot cover **2**.
 3. Short across the power-on password jumper pads **3**.

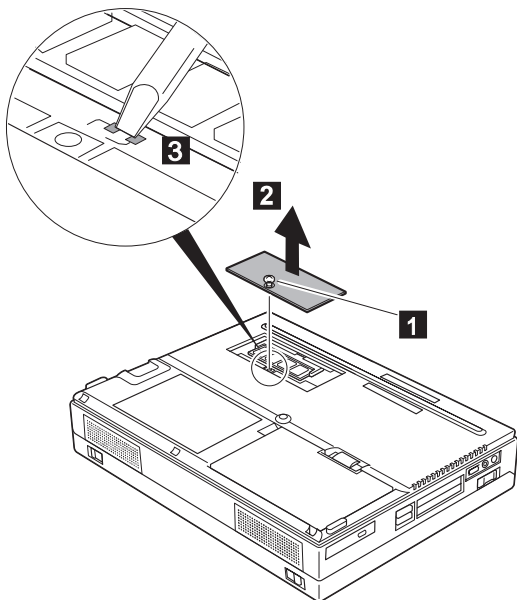

4. Turn on the computer to clear the password, and wait until the POST ends.
5. Reinstall the memory-slot cover, and turn the computer right side up.

Verify that the password prompt does not appear.

To reactivate the password, set the password again.

- **When both the power-on password and the supervisor password are set.**
 1. Turn off the computer.
 2. Turn the computer upside down, loosen the memory-slot cover screw **1**, remove the memory-slot cover **2**.
 3. Short the two password jumper pads on the system board (see **3** of the previous page).
 4. Turn on the computer. After a few seconds, the password prompt appears.
 5. Enter the **supervisor password**. The “Easy-setup main menu” appears.
 6. Select **Password** and then **Power on**. A rectangular box appears.
 7. Enter the **supervisor password** and press the **Space bar** once.
 8. Press **Enter** twice.
 9. Select **Exit**.
 10. Select **Restart** in the “Easy-setup main menu” and wait until the POST ends.
 11. Reinstall the memory-slot cover, and turn the computer right side up.

Verify that the password prompt does not appear.

To reactivate the password, set the password again.

Power Shutdown Switch: The power shutdown switch resets the system regardless of the microcode status and forces a power off. Use this push button to power off when power is not completely off or when the microcode is in a hung state.

Hole for Power Shutdown Switch

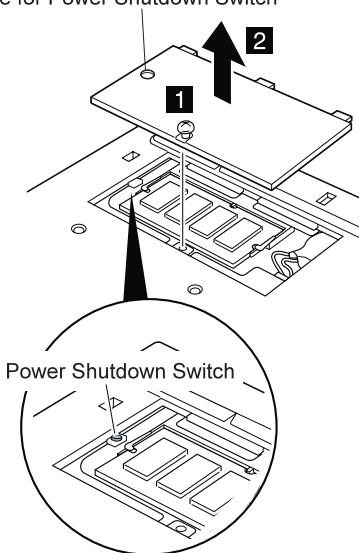

Product Overview

The following table is an overview of the system features of the IBM ThinkPad 380XD or 385XD computer.

Feature	Description
Processor	<p>380XD 2635-8xx/9xx/Bxx</p> <ul style="list-style-type: none"> Intel® Pentium® 233 MHz with MMX™ <p>2635-Axx</p> <ul style="list-style-type: none"> Intel® Pentium® 266 MHz with MMX™ <p>2635-Exx</p> <ul style="list-style-type: none"> Intel® Pentium® II 233 MHz with MMX™ <p>2635-Fxx</p> <ul style="list-style-type: none"> Intel® Pentium® II 266 MHz with MMX™ <p>385XD 2635-8xx</p> <ul style="list-style-type: none"> Intel® Pentium® 233 MHz with MMX™ <p>2635-9xx</p> <ul style="list-style-type: none"> Intel® Pentium® 266 MHz with MMX™ <p>2635-Dxx</p> <ul style="list-style-type: none"> Intel® Pentium® II 266 MHz with MMX™
Bus Architecture	PCI Bus
Memory (Standard)	<ul style="list-style-type: none"> 32MB (on the system board)
Memory (Option)	<p>2635-8xx/9xx/Axx/Bxx</p> <ul style="list-style-type: none"> 8MB and 16MB 70ns EDO DIMM card 16MB, 32MB, and 64MB EDO DIMM card (max. 96MB) <p>2635-Dxx/Exx/Fxx</p> <ul style="list-style-type: none"> 16MB, 32MB, and 64MB 60ns EDO DIMM card (max. 96MB)
CMOS RAM	242 bytes
LCD	<p>380XD 2635-8xx/Exx</p> <ul style="list-style-type: none"> 12.1-inch, 16M colors, 800×600 pixel HPA¹ color LCD <p>2635-9xx/Axx/Bxx/Fxx</p> <ul style="list-style-type: none"> 12.1-inch, 16M colors, 800×600 pixel TFT color LCD <p>385XD 2635-8xx/9xx/Dxx</p> <ul style="list-style-type: none"> 12.1-inch, 16M colors, 800×600 pixel HPA² color LCD
Diskette Drive (Internal)	<ul style="list-style-type: none"> 1.44 MB (3-mode), 3.5-inch

Feature	Description
CD-ROM Drive	<ul style="list-style-type: none"> • 10x—24x
Hard Disk Drive	<p>380XD 2635-8xx</p> <ul style="list-style-type: none"> • 3.2-GB, 2.5-inch, IDE interface <p>2635-9xx/Exx</p> <ul style="list-style-type: none"> • 4.0-GB, 2.5-inch, IDE interface <p>2635-Axx/Fxx</p> <ul style="list-style-type: none"> • 5.1-GB, 2.5-inch, IDE interface <p>385XD 2635-8xx</p> <ul style="list-style-type: none"> • 2.1-GB, 2.5-inch, IDE interface <p>2635-9xx/Dxx</p> <ul style="list-style-type: none"> • 3.2-GB, 2.5-inch, IDE interface
I/O Port	<ul style="list-style-type: none"> • Serial • Parallel • USB • External monitor • Headphone • Microphone • Port replicator
Audio	<ul style="list-style-type: none"> • 16-bit audio • Internal speakers • Internal microphone • Mechanical volume
Infrared Transfer	<ul style="list-style-type: none"> • IrDA 1.1
PC Card	<ul style="list-style-type: none"> • One Type III or two Type I / Type II • CardBus support • ZV card support
AC Adapter	56Watt type
Note: 1: High Performance Addressing	

Checkout Guide

Use the following procedure as a guide for computer problems. The diagnostic tests are intended to test only IBM products. Non-IBM products, prototype cards, or modified options can give false errors and invalid system responses.

1. Obtain the symptoms in detail.
2. Verify the symptoms by running the diagnostic test to re-create the same error or by repeating the same operation.

Note

To run the diagnostic test, refer to "Running the Diagnostics" on page 49. If the symptoms occur at irregular intervals and cannot be re-created (and therefore cannot be verified), go to "Symptom-to-FRU Index" on page 38; then go to "Intermittent Problems" on page 47.

3. Match the verified symptoms with the following table and determine the page to go to.

Verified Symptoms	Go To
Power failure. (The power indicator does not go on or stay on.)	"Power Systems Checkout" on page 29.
POST does not complete. No beeps or error codes are displayed.	"Symptom-to-FRU Index" on page 38, and then go to "No Beep Symptoms" on page 43.
The configuration is not the same as the installed devices.	"Checking the Installed Devices List" on page 50.
POST beeps, but no error codes are displayed.	"Symptom-to-FRU Index" on page 38, and then go to "Beep Symptoms" on page 43.
POST detected an error and displayed numeric error codes.	"Symptom-to-FRU Index" on page 38, and then go to "Numeric Error Codes" on page 38.
The diagnostic test detected an error and displayed a FRU code.	"FRU Codes" on page 53.
Other symptoms (such as LCD monitor problems).	"Symptom-to-FRU Index" on page 38, and then go to "Other Symptoms" on page 47.

Audio Checkout

1. Go to the diagnostic menu by selecting **Test** in the Easy-Setup menu.
2. Select **Audio** and run the diagnostic tests.
3. If the test detects an audio problem, replace the system board.

Diskette Drive Checkout

This checkout is to isolate the problem to a controller, drive, or diskette. A write-enabled, blank, formatted 2HD diskette is required.

FDD-1 represents a diskette drive in the ThinkPad computer.

Attention

Make sure that the diskette does not have more than one label on its surface. Inserting diskettes with multiple labels into the drive can damage it.

Take the following procedure to select the test device:

1. Click on **Test** in the Easy-Setup menu.
2. Press **Ctrl+A** to enter the advanced diagnostic menu. The ThinkPad FRU Connections window appears.
3. Click on **Exit**. The keyboard layout appears on the screen.
4. Click on **Exit**.
5. Click on **FDD-1**.
6. Type **Y** (Yes) to the question that appears on the screen. Insert a blank diskette into the drive when instructed.
7. Press **Enter** to run the diskette drive test.
 - a. If the controller test detects an error and FRU code 10 appears, replace the system board.
 - b. If the controller test runs without any errors, the drive read/write tests start automatically.
 - c. If the drive read/write test detects an error and either FRU code 50 for FDD-1 appears, replace the drive.

If the drive is attached to a port replicator, go to "Port Replicator Checkout" on page 33 to isolate the replicator. Otherwise, go on to the next step.
8. If the drive is attached through a port replicator, go to the service manual of the port replicator to isolate the problem.
9. If no error occurs when you test the formatted diskette, suspect the diskette that the customer used when reporting the problem.

Fan Checkout

To check the fan, listen for the fan. If you cannot hear it running at power-on, replace the fan. If you can hear it running but not steadily, do the diagnostic test.

1. Start Easy-Setup.
2. Click on **Test**.
3. Press **Ctrl+A** to enter the advanced diagnostic mode. The ThinkPad Connection windows appear.
4. Click on **Exit**. The keyboard layout appears on the screen.
5. Click on **Exit**.
6. Click on **System Board** then press **Enter** to run the test.

Follow the instructions that appear on the screen. If the test detects a fan problem, replace it.

Keyboard or Auxiliary Input Device Checkout

Remove any external keyboard before testing the built-in keyboard.

If the keyboard does not work or an unexpected character appears, make sure that the flexible cable extending from the keyboard is correctly seated in the connector on the DC/DC card.

If the keyboard cable connection is correct, check the DC/DC card.

If the tests do not detect a keyboard problem, run the **keyboard test** by doing the following:

1. Go to the diagnostic menu by selecting **Test** in the Easy-Setup menu.
2. Press **Ctrl+A** to enter to the advanced diagnostic mode.
The ThinkPad FRU Connections window appears. (If **Ctrl+A** does not work, triple-click on the icon on the right bottom corner of the basic diagnostic window.)
3. Make sure that the keyboard connection is **Connected**; then press **Esc** to exit the screen. A layout of the keyboard appears on the screen.
4. Check that when each key is pressed, the key's position on the keyboard layout on the screen changes to a black square.
Note: When the **Fn** key is pressed, a black square appears briefly.
5. Press **Ctrl+Pause** to end the test.

If the tests detect a keyboard problem, do the following one at a time:

Warning: Do not replace a nondefective FRU.

- Reseat the keyboard cables.
- Replace the DC/DC card.

- Replace the system board.

Auxiliary Input Devices: The following auxiliary input devices are supported:

- Numeric keypad
- Mouse (PS/2 compatible)
- External keyboard (with keyboard/mouse cable)

If any of these devices do not work, reseal the cable connector and repeat the failing operation.

If the problem remains, replace the device, and then the system board.

Memory Checkout

DIMMs are available for increasing memory capacity.

DIMM	Displayed Value
No DIMM installed	32192 KB
8 MB	40384 KB
16 MB	48576 KB
32 MB	64960 KB
64 MB	97728 KB

Memory errors may cause error messages to appear on the screen or may hang the operating system.

Take the following procedure to isolate memory problems:

1. Turn off the computer and remove any installed DIMM from the slot.
2. Press and hold the **F1** key; then turn on the computer. Hold the **F1** key down until the Easy-Setup menu appears.
3. Select **Test** and press **Enter**.
4. Select **Memory** and press **Enter** to run the memory test for the base memory. If an error appears, replace the system board.
5. Turn off the computer and reinstall the DIMM; then turn on the computer. Verify the memory size; then test the memory. If an error message appears, replace the DIMM.

If a memory problem occur intermittently, perform the loop option test. If the test detects an error, it prints an error log on a printer connected to the parallel port. See "Displaying the Error Log" on page 50 for more information.

Flash Memory Update: System setup programs and diagnostic tests are stored in the flash memory. A flash memory update is required when:

- A new version of the system program is installed.
- A new features or options is added to the computer.

To update the flash memory, do the following:

1. Obtain an appropriate diskette containing the update.
2. Insert the System Program Service diskette into drive A, and turn on the computer with ac power or a fully charged battery.
3. Select **Update system programs** from the menu.

Power Systems Checkout

To determine whether a power systems problem is due to the AC Adapter or the battery, do the following:

1. Remove the battery.
 2. Connect the AC Adapter and check that power is supplied.
 3. Disconnect the AC Adapter and install the charged battery; then check that power is supplied by the battery.
- If the problem is due to the AC Adapter, go to “AC Adapter Checkout”
 - If the problem is due to the battery, go to “Battery Checkout” on page 30

If the problem is not due to the AC Adapter or the battery, go to “Backup Battery Checkout (Nonrechargeable)” on page 31

AC Adapter Checkout: This checkout is used only when the computer fails under ac power.

- If the problem occurs only when the AC Adapter is used with a port replicator, replace the replicator.
 - If the power-on indicator does not turn on, check the power cord of the AC Adapter for conductivity and installation.
1. Unplug the AC Adapter cable from the computer and measure the output voltage at the cable plug. See the following figure:

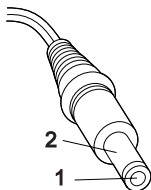

Pin	Voltage (V dc)
1	+15.5 to +17.0
2	Ground

- a. If the voltage persists, go to the next step.
- b. If the voltage is correct, make sure the connection between the DC/DC card and the system board is not loose.

- c. Replace the DC/DC card.
 - d. If the problem is not corrected, replace the system board.
 - e. If the problem persists, go to “Undetermined Problems” on page 48.
2. Unplug the AC Adapter cable from the ac power outlet and wait 5 minutes or longer to allow the overvoltage protection circuit to be fully discharged and initialized.
 3. Plug the AC Adapter cable into the ac power outlet.
 4. Measure the output voltage of the AC Adapter.
 5. If the voltage is still not correct, replace the AC Adapter.

Note: An audible noise from the AC Adapter does not always indicate a defect.

Battery Checkout: If the error is due to the battery, do the following:

1. Turn off the computer.
2. Remove the battery and measure the voltage between the battery terminals 1 (+) and 4 (-).

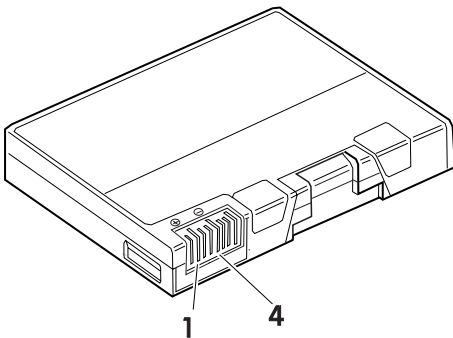

Terminal	Voltage (V dc) / Signal
1	+0 to +13.5
4	Ground (-)

Note: Signal lines not used in these steps are used for communication between the system and the battery.

3. If the voltage is less than +11.0 V dc, the battery has been discharged. Recharge the battery.

If the voltage is still less than +11.0 V dc after recharging, replace the battery.

Note: The voltage of the battery could show 0 V because of the overdischarge protection circuit. Try to trickle charge the battery by attaching it to the computer with the AC adapter.

- If the voltage is more than +11.0 V dc, measure the resistance between the battery terminals 3 and 4. The resistance must be 4 to 30 K ohms.

If the resistance is not correct, replace the battery.

If the resistance is correct, replace the DC/DC card.

Checking Operational Charging

Note

Battery charging will not start unless the Fuel-Gauge is below 95%. At below 95%, the battery will start charging to 100% of its capacity. This limitation protects the battery from overcharging and also prolongs its life.

To check the operational charging, install a fully discharged battery or a battery that is less than 50% charged.

Turn on the computer while it is connected to the AC Adapter. If the battery status indicator does not turn on, turn off the computer, remove the battery, and let the battery return to room temperature. Reinstall the battery, and turn on the computer (still connected to the AC Adapter). If the charge indicator still does not turn on, replace the battery.

Backup Battery Checkout (Nonrechargeable)

- Turn off the computer and unplug the AC Adapter from the computer.
- Open the Memory-slot cover.
- Remove the backup battery. (Refer to "1010 DIMM Card and Backup Battery" on page 62 to remove the battery.)
- Measure the voltage of the backup battery connector.

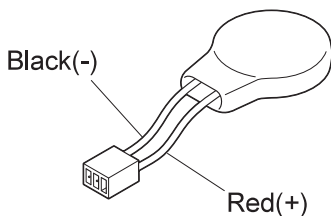

Wire	Voltage (V dc)
Red	+2.5 to +3.7
Black	Ground

- If the voltage is correct, replace the system board.
- If the voltage is not correct, the backup battery has been discharged. Replace the backup battery.
- If the backup battery discharges quickly after replacement, replace the system board.

Status Indicator Checkout

If an LED problem occurs, do the following:

1. Turn off the computer.
2. Turn on the computer.
3. All the LEDs in the indicator panel should turn on for a moment soon after the computer is powered on. Make sure they turn on.

If the problem persists, replace the system board.

System Board and CPU Card Checkout

The system board and the CPU Card FRUs perform the operation on the computer. Processor problems can be caused by either FRU. Generally, the CPU Card has a lower failure rate. If a numeric code indicates the system board or the CPU Card as failing, do the following procedure to isolate the problem:

1. Run the system board test to verify the symptom. This test verifies both the system board and the CPU Card. If no error is detected, return to “Undetermined Problems” on page 48.

Note: Do not touch the keyboard and the pointing device when the system board is being tested. This might cause unexpected errors.

2. If FRU code 10 appears, replace the system board, but do not replace the CPU Card. Transfer the CPU Card from the old system board to the new system board.
3. If FRU code 11 appears, reseal the CPU Card.
4. Rerun the test to verify the fix.
5. If FRU code 11 remains, replace the CPU Card.

If this procedure does not correct the problem, go to “Undetermined Problems” on page 48.

TrackPoint III Checkout

If the TrackPoint III does not work, do the following:

1. Run the ThinkPad Configuration program and check if the configuration of the TrackPoint III is enabled.
2. If it is not, select **Enable** and enable it.
3. If you still have a problem, continue to the next step.

Drifting Pointer

There may be cases when the pointer drifts for a short while on the screen, this is not a hardware problem. This movement can occur when a slight, steady pressure is applied to the TrackPoint III pointer. No service action needs be taken.

4. Go to the Easy-Setup menu.
5. Move to an item with the pointing stick.
6. Press any one of the two click buttons.
7. Verify that the item is selected.
8. Verify that all buttons work correctly.
9. If the problem still persists, do the following one at a time:

Warning: Do not replace a nondefective FRU.

- Reseat the TrackPoint III cable.
- Replace the keyboard.
- Replace the DC/DC card.
- Replace the system board.

Optional Device Checkout

If you suspect an optional device problem, do either of the following:

- "Port Replicator Checkout"
- "External Monitor Self-Test"

Port Replicator Checkout

Do the following procedures to isolate a port replicator problem. A port replicator attaches to the system expansion connector at the rear of the computer.

1. Turn off the computer.
2. Remove the failing devices from the replicator.
3. Unplug the AC adapter from the replicator, if attached.
4. Remove the port replicator from the computer.
5. Reconnect the failing device directly to the computer. (If another device is already connected to the computer, remove it first.)
6. Go to the "Running the Diagnostics" on page 49 and run the diagnostics.
7. If the advanced diagnostic device test does not find an error, suspect a problem with the port replicator of the system expansion bus.
8. Turn off the computer and reconnect the port replicator.
9. Turn on the computer and run the following advanced diagnostic tests:
 - Serial port test with the wrap plug installed on the replicator

- Parallel port test with the wrap plug installed on the replicator
10. If diagnostic errors appear, replace the replicator or diskette drive attachment unit.
If the problem remains after the replacement, replace the system board.
 11. If power problems appear only when the replicator is used, replace the replicator.

External Monitor Self-Test

If a monitor problem occurs only when an external monitor is connected, do the following:

Note: Before you replace a monitor:

- Check that the 95XX systems support either 63XX, 85XX, or 95XX displays.
- Make sure that the external monitor is properly connected to the computer.

If the screen is rolling, replace the external monitor. If that does not correct the problem, replace the FRUs in the following order:

1. System board
2. Bus adapter (if used)

If the screen is not rolling, run the monitor self-test as follows:

1. Power-off the computer and monitor.
2. Disconnect the monitor signal cable.
3. Power-on the monitor
4. Set the contrast to its maximum position.
5. Set the brightness control to the center detent position.

Check the following conditions:

- The screen contrast and brightness control are adjustable.
- The screen is either white or light gray, with a black margin (test margin).
- The screen is set to **CRT** or **both** on the ThinkPad Configuration program.

Note: The location of the test margin may vary with the type of monitor. It can be either at the top and/or bottom, or left and/or right of the screen.

If you do not see a test margin on the screen, replace the monitor. If there is a test margin on the screen, replace the system board.

Power Management Features

Three power management modes are provided by the computer to reduce power consumption and to prolong battery life.

Standby Mode: In standby mode, the following occurs:

- The LCD backlight turns off.
- The hard disk drive motor stops.

The following events cause the computer to enter standby mode:

- Standby is requested by the **Fn** key (**Fn+F3**).
- There is inactivity under **auto-standby** mode set by the ThinkPad Configuration program.

The computer exits standby mode and resumes operation when any key is pressed.

Suspend Mode: In suspend mode, the following occurs:

- The LCD backlight turns off.
- The hard disk drive motor stops.
- The LCD is powered off.
- The hard disk drive is powered off.
- The CPU stops.

The following events cause the computer to enter suspend mode:

- Suspend mode is requested by the **Fn** key (**Fn+F4**).
- The LCD is closed.
- A time-out occurred on the following devices:
 - Keyboard
 - TrackPoint III
 - Hard disk drive
 - Parallel connector
 - Diskette drive
 - AC Adapter

The duration of inactivity is specified in **Suspend Timer** of the ThinkPad Configuration program.

- The battery power is low and the orange battery power indicator blinks.
- Either the PS2 OFF or the PS2 SUSpend command is set in the ThinkPad Configuration program.

Notes:

1. To disable suspend mode, set the mode to “Will not suspend even if LCD is closed.” in the ThinkPad Configuration program.
2. If the computer is being powered by ac power and a communication PC Card is being used, the computer enters *standby mode* instead of entering the normal *suspend mode*, and the PC Card and application programs remain active.
3. The computer will not enter suspend mode when a communication link is active.

The following events cause the computer to return from suspend mode to normal operation:

- The LCD is opened.
- The real time clock alarm is signaled.
- The ring indicator (RI) is signaled by a serial device or a PC Card device.
- The **Fn** key is pressed.
- An external keyboard key is pressed while the computer is operating with ac power.

The computer exits suspend mode and enters hibernation mode when a preset timer condition is satisfied.

Hibernation Mode: In hibernation mode, the following occurs:

- The system status, RAM, VRAM, and setup data are stored on the hard disk.
- The computer is powered off.

Notes:

The computer cannot enter hibernation mode if it is being powered by ac power and a communication PC Card is used.

The following events cause the computer to enter hibernation mode:

- Hibernation mode is requested by the **Fn** key (**Fn+F12**).
- Timer conditions are satisfied in suspend mode.
- A critically low battery condition occurs.
- The PS2 HIBernation command is set in the ThinkPad Configuration program.

The computer exits hibernation mode and resumes operation when the power-on switch is pressed. When power is turned on, the hibernation file in the boot record on the hard disk drive is read and system status is restored from the hard disk drive.

Port Replicator Power Overload: If a power shutdown occurs intermittently when PC Card devices are used with a port replicator, suspect an over-current problem. Some PC Card devices use much power, and if at some point the required power exceeds the allowed power, a power shutdown occurs. Isolate this problem to a device by removing each device simultaneously and then using the computer under the same condition as when the power shutdown occurred. This will determine which device is causing the overload.

Symptom-to-FRU Index

The Symptom-to-FRU Index lists the symptoms and errors and the possible causes. The most likely cause is listed first.

Note: Perform the FRU replacement or actions in the sequence shown in the “FRU/Action” columns. If a FRU replacement did not solve the problem, put the original part back in the computer. Do not replace a nondefective FRU.

This index can also help you determine the next possible FRUs to be replaced when servicing a computer.

Numeric error codes show the errors detected in POST or system operation. In the following error codes, **X** can be any number.

If no codes are available, use narrative symptoms.

If the symptom is not listed, go to “Undetermined Problems” on page 48.

Note: For IBM devices not supported by diagnostic codes in the ThinkPad notebook computers, see the manual for that device.

Numeric Error Codes

Symptom / Error	FRU / Action in Sequence
10X 101: Interrupt failure. 102: Timer failure. 103: Timer interrupt failure. 104: Protected mode failure. 105: Last 8042 command not accepted. 107: NMI test failure. 108: Timer bus test failure. 109: Low meg-chip select test.	System board
110 (Planar parity.)	<ol style="list-style-type: none">1. Go to “Memory Checkout” on page 28.2. DIMM3. Detach the expansion unit if it is attached to the computer.4. System board

Symptom / Error	FRU / Action in Sequence
111 (I/O parity.)	<ol style="list-style-type: none"> 1. Go to “Memory Checkout” on page 28. 2. Port replicator 3. System board
158 (Hard disk password is not set even though the supervisor password is set.)	Set the password for hard disk drive.
159 (Hard disk password is not set the same as the supervisor password.)	Set the correct password for hard disk drive.
161 (Dead battery.)	<ol style="list-style-type: none"> 1. Go to “Backup Battery Checkout (Nonrechargeable)” on page 31. 2. Backup battery 3. System board
163 (Time and date were not set.)	<ol style="list-style-type: none"> 1. Set time and date. 2. System board
173 (Configuration data was lost.)	<ol style="list-style-type: none"> 1. Select OK in the error screen; then set the time and date. 2. Backup battery 3. System board
174 (Configuration error: Perform “Checking the Installed Devices List” on page 50 before changing any FRUs.)	<ol style="list-style-type: none"> 1. Check device configuration. 2. Hard disk drive 3. System board
175, 177, 178 175: EEPROM CRC #1 error. 177: Supervisor password check sum error. 178: EEPROM is not functional.	System board
183 (Incorrect password entered at the supervisor password prompt.)	Have the user examine the password.
184 (Power-on password check sum error.)	Reset the power-on password in Easy-Setup.
185 (The start-up sequence is not valid. Probably the computer was powered off when the start-up sequence was being updated.)	Reset the start-up sequence in Easy-Setup.

Symptom / Error	FRU / Action in Sequence
186	System Board
190 (A depleted battery pack was installed when the power was on.)	Go to “Battery Checkout” on page 30.
191XX (PM initialization error.)	System board
192 (Fan error)	<ol style="list-style-type: none"> Fan System board
195 (The configuration read from the hibernation data storage area does not match the actual configuration.)	<p>Check if the configuration was changed. For example, check if the DIMM is added.</p>
196 (A read error occurred in the hibernation area of the hard disk drive.)	<ol style="list-style-type: none"> Run the hard disk drive test. Hard disk drive
199XX (Resume error.)	System board
1XX	System board
225 (Unsupported memory module)	<ol style="list-style-type: none"> Check if a supported DIMM is installed. DIMM Card System board
2XX 201: Memory data error. 202: Memory line error 00–15. 203: Memory line error 16–23. 205: Memory test failure on on-board memory. 221: ROM to RAM remap error.	<ol style="list-style-type: none"> Go to “Memory Checkout” on page 28. DIMM System board
301, 303, 304, 305, 3XX (301: Keyboard error.)	<ol style="list-style-type: none"> Go to “Keyboard or Auxiliary Input Device Checkout” on page 27. Keyboard External numeric keypad External keyboard Keyboard/mouse cable DC/DC card System board

Symptom / Error	FRU / Action in Sequence
601, 6XX (601: Diskette drive or controller error.)	<ol style="list-style-type: none"> 1. Go to “Diskette Drive Checkout” on page 26. 2. CD-ROM and FDD assembly 3. Diskette 4. System board
602 (Diskette read error.)	<ol style="list-style-type: none"> 1. Go to “Diskette Drive Checkout” on page 26. 2. Diskette 3. CD-ROM and FDD assembly
604 (An unacceptable ID was read from the diskette drive.)	<ol style="list-style-type: none"> 1. Go to “Diskette Drive Checkout” on page 26. 2. CD-ROM and FDD assembly 3. System board
11XX 1101: Serial_A test failure.	<ol style="list-style-type: none"> 1. Serial device 2. Communication cable 3. System board
12XX 1201: Serial_B test failure.	<ol style="list-style-type: none"> 1. System board (infrared)
17XX 1701: Hard disk controller failure. 1780, 1790: Hard disk 0 error. 1781, 1791: Hard disk 1 error.	<ol style="list-style-type: none"> 1. Hard disk drive 2. System board
24XX (2401: System board video error.)	System board
808X 8081: PCMCIA presence test failure. (PCMCIA revision number also checked.) 8082: PCMCIA registration test failure.	<ol style="list-style-type: none"> 1. PC Card slot assembly 2. PCMCIA device 3. System board
860X (Pointing device error when TrackPoint III is disabled.) 8601: System bus error—8042 mouse interface. 8602: External mouse error. 8603: System bus error or mouse error.	<ol style="list-style-type: none"> 1. External mouse 2. External keyboard 3. System board

Symptom / Error	FRU / Action in Sequence
<p>861X (Pointing device error when TrackPoint III is enabled.)</p> <p>8611: System bus error—I/F between 8042 and IPDC. 8612: TrackPoint error. 8613: System board or TrackPoint error.</p>	<ol style="list-style-type: none"> 1. Reseat the keyboard cable on the DC/DC card 2. Keyboard 3. External mouse 4. DC/DC card 5. System board
<p>I9990301 I9990302 I9990305</p> <p>I9990301: Hard disk error. I9990302: Invalid hard disk boot record. I9990305: No bootable device.</p>	<ol style="list-style-type: none"> 1. Check that the operating system is installed in the hard disk drive. If not, install the operating system. 2. Reseat the boot device. 3. Check the start-up sequence for the correct boot device. 4. Check that the operating system boots correctly.
<p>I9990303 (Bank–2 flash ROM check sum error.)</p>	<p>System board</p>
<p>Other codes not listed above.</p>	<p>Go to “Undetermined Problems” on page 48.</p>

Beep Symptoms

Symptom / Error	FRU / Action in Sequence
Continuous beeps.	System board
One beep and a blank, unreadable, or flashing LCD.	<ol style="list-style-type: none"> 1. Reseat the LCD connector 2. LCD assembly 3. System board
One beep, and the message "Unable to access boot source" appears.	<ol style="list-style-type: none"> 1. Boot device 2. System board
One long and two short beeps, and a blank or an unreadable LCD.	<ol style="list-style-type: none"> 1. System board 2. LCD assembly
One long beep followed by four short beeps each time the power switch is operated. (System cannot turn on due to low battery voltage.)	Connect the AC Adapter or install a fully charged battery.
One beep every second. (System is shutting down due to low battery voltage.)	Connect the AC Adapter or install a fully charged battery. (Allow the system to completely shut down before changing the battery.)
Two short beeps with error codes.	POST error. See "Numeric Error Codes" on page 38.
Two short beeps and a blank screen.	System board

No Beep Symptoms

Symptom / Error	FRU / Action in Sequence
No beep, power-on indicator not on, and a blank LCD during POST.	<ol style="list-style-type: none"> 1. Go to "Power Systems Checkout" on page 29. 2. DC/DC card 3. System board 4. CPU Card 5. Check the power outlet
No beep, power-on indicator on, and a blank LCD during POST.	<ol style="list-style-type: none"> 1. DC/DC card 2. System board 3. CPU Card
No beep, power-on indicator on, and a blinking cursor only during POST.	<ol style="list-style-type: none"> 1. DC/DC card 2. CPU Card 3. System board
No beep during POST but the system runs correctly.	<ol style="list-style-type: none"> 1. Turn the volume up and check the speaker. 2. Speaker 3. System board

Function-Related Symptoms

Symptom / Error	FRU / Action in Sequence
The system does not suspend or resume when the LCD is closed or opened.	<ol style="list-style-type: none"> 1. Go to “Suspend Mode” on page 35, and check that the computer can enter suspend mode. 2. Boot an operating system and press Fn+F4. If the computer enters suspend mode, suspect that the application program is not working properly. 3. LCD assembly 4. System board
The battery Fuel-Gauge does not go higher than 90%.	Go to “Battery Checkout” on page 30 and see the note.
The memory count (size) appears different from the actual size.	Go to “Memory Checkout” on page 28.
The system configuration does not match the installed devices.	Go to “Checking the Installed Devices List” on page 50.
The system hangs intermittently.	Go to “Intermittent Problems” on page 47.

Indicator-Related Symptoms

Symptom / Error	FRU / Action in Sequence
The indicator incorrectly remains off or on, but the system runs correctly.	<ol style="list-style-type: none"> 1. System board 2. DC/DC card
The battery power status indicator blinks from green, yellow, to orange.	<ol style="list-style-type: none"> 1. Check that a correct battery is installed. 2. Battery pack 3. DC/DC card 4. System board
The battery indicator does not turn on when the battery is installed.	<ol style="list-style-type: none"> 1. DC/DC card 2. Battery pack 3. System board

Infrared-Related Symptoms

Symptom / Error	FRU / Action in Sequence
Unable to communicate using the Infrared (IR) Port.	<ol style="list-style-type: none">1. Make sure the setup for the IR is correct. Use the ThinkPad Configurations utility.2. Make sure there are no fluorescent lights near the computer. The computer may receive optical noise from the fluorescent light.3. Run the advanced diagnostic test. If an error occurs and a FRU code is displayed, replace the parts shown by the FRU code.

Keyboard- or TrackPoint III-Related Symptoms

Symptom / Error	FRU / Action in Sequence
The keyboard (one or more keys) does not work.	<ol style="list-style-type: none">1. Reseat the keyboard cable on the DC/DC card.2. Keyboard3. System board
The TrackPoint III does not work.	<ol style="list-style-type: none">1. Reseat the keyboard cable on the DC/DC card.2. Go to "TrackPoint III Checkout" on page 32.3. Keyboard4. System board
The pointer moves automatically or does not work correctly.	See "TrackPoint III Checkout" on page 32.

LCD-Related Symptoms

Important

The TFT LCD for the notebook computer contains over 921,000 thin-film transistors (TFTs). A small number of missing, discolored, or lighted dots (on all the time) is characteristic of TFT LCD technology, but excessive pixel problems can cause viewing concerns. The LCD should be replaced if the number of missing, discolored, or lighted dots in any background is **21 or more**.

Symptom / Error	FRU / Action in Sequence
No beep, power-on indicator on, and a blank LCD during POST.	<ol style="list-style-type: none"> 1. Reseat the CPU Card 2. DC/DC card 3. System board
<ol style="list-style-type: none"> 1. LCD backlight not working. 2. LCD too dark. 3. LCD brightness cannot be adjusted. 4. LCD contrast cannot be adjusted. 	<ol style="list-style-type: none"> 1. Reseat the LCD connectors. 2. LCD assembly 3. System board
<ol style="list-style-type: none"> 1. The LCD screen is unreadable. 2. Some pels missing in characters. 3. The screen is abnormal. 4. Wrong color displayed. 	<ol style="list-style-type: none"> 1. See important note for "LCD-Related Symptoms." 2. Reseat all LCD connectors. 3. LCD assembly 4. System board
LCD has extra horizontal or vertical lines displayed.	LCD assembly

Peripheral-Device-Related Symptoms

Symptom / Error	FRU / Action in Sequence
The external monitor does not work correctly.	Connect the external monitor to another PC. If the monitor works fine, replace the system board. If not, replace the external monitor.
Printer problems.	<ol style="list-style-type: none"> 1. Run printer self-test. 2. Parallel port wrap test. 3. System board 4. Printer cable <p>(See the printer manual for the above tests.)</p>

Symptom / Error	FRU / Action in Sequence
Serial or parallel port device problems.	<ol style="list-style-type: none"> 1. Run serial or parallel port wrap test. (See the device manual for the test.) 2. Device 3. System board 4. Device cable

Power-Related Symptoms

Symptom / Error	FRU / Action in Sequence
Power shuts down during operation.	<ol style="list-style-type: none"> 1. Go to “Power Systems Checkout” on page 29. 2. Battery pack 3. Remove the battery pack and let it cool for 2 hours. 4. DC/DC card 5. System board 6. Check the power outlet.
The system does not power off. (See “Power Shutdown Switch” on page 22.)	<ol style="list-style-type: none"> 1. Press the power shutdown switch. 2. DC/DC card 3. System board

Other Symptoms

Symptom / Error	FRU / Action in Sequence
Errors occur only when the port replicator is used.	See “Port Replicator Checkout” on page 33.
PC Card slot pin is damaged.	PC Card slots assembly.

Note: If you cannot find a symptom or an error in this list and the problem remains, see “Undetermined Problems” on page 48.

Intermittent Problems

Intermittent system hang problems can be caused by a variety of reasons that have nothing to do with a hardware defect, such as: cosmic radiation, electrostatic discharge, or software errors. FRU replacement should be considered only when a recurring problem exists.

When analyzing the intermittent problem, do the following:

1. Run the advanced diagnostic test for the system board in loop mode **at least 10 times**.
2. If no error is detected, do **not** replace any FRUs.

3. If any error is detected, replace the FRU shown by the FRU code. Rerun the test to verify that no more errors exist.

Undetermined Problems

You are here because the diagnostic tests did not identify which adapter or device failed, installed devices are incorrect, a short circuit is suspected, or the system is inoperative. Follow these procedures to isolate the failing FRU (do not isolate nondefective FRUs).

Verify that all attached devices are supported by the computer.

Verify that the power supply being used at the time of the failure is operating correctly. (See "Power Systems Checkout" on page 29):

1. Turn off the computer.
2. Visually check them for damages. If any problems are found, replace the FRU.
3. Remove or disconnect all of the following devices:
 - a. Non-IBM devices
 - b. Devices attached to the port replicator
 - c. Printer, mouse, and other external devices
 - d. Battery pack
 - e. Hard disk drive
 - f. CD-ROM and FDD
 - g. DIMM
 - h. PC Cards
4. Turn on the computer.
5. Determine if the problem is solved.
6. If the problem is solved, reconnect the removed devices one at a time until you find the failing FRU.
7. If the problem remains, replace the following FRUs one at a time. Do not replace a nondefective FRU.
 - a. System board
 - b. DC/DC card
 - c. LCD assembly
 - d. CPU Card

Running the Diagnostics

Use either TrackPoint III or the cursor move keys to interact with the tests.

The following table lists the special tools used in the diagnostics:

Tool Name	Part Number
PC test card	35G4703
Tri-Connector wrap plug	72X8546
USB parallel test cable	05K2580

Use either TrackPoint III or the cursor move keys to interact with the tests. The **Enter** key works in the same way as when selecting the **OK** icon to reply OK.

1. Press and hold **F1**; then turn on the computer. Hold **F1** down until the Easy-Setup menu appears.
2. Click on **Test**. The basic diagnostic menu appears.
3. Click on a device to run the test. The test progress window appears; then **OK** appears under the tested device icon when the test ends without any errors.
4. Start the **Advanced Diagnostic test** by pressing **Ctrl+A** on the basic diagnostic menu. The ThinkPad FRU connections window appears.
5. Click on **Exit** or press the **Esc** key. The keyboard test window appears.
6. When you press a key, a mark appears or disappears on the corresponding key position on the screen. Repeat this step for any key that needs to be tested. You can run the keyboard test if you press the **Ctrl+K** keys at the advanced diagnostic menu.
7. To exit the keyboard test, click on **Exit** or press the **Ctrl+Break** keys. The Advanced Diagnostics menu appears.

- Click on a device to test, or click on **Test All** to test all devices.

Click on **Looptest** to run the tests in a repeated loop. The loop option menu appears. Click on a device; a ✓ mark appears beside the selected device. Repeat this step to select multiple devices. Click on **OK** to start the diagnostic loop. If no device is selected, all devices tests are looped.

- To exit the loop, keep pressing **Ctrl+Pause**. A beep sounds to notify that exit interrupt is sensed by the test program. Press **Esc** to exit from the loop test.

PC Card (PCMCIA) Slots Test

The green LED on the PC test card (P/N 35G4703) turns on when the PC Card (PCMCIA) slot test is running. If the LED does not turn on, check that the card is installed correctly by reseating it. If the LED still does not turn on after the card is reseated, try using another slot for the test. If the LED still does not turn on and the test fails, replace the FRU shown by the diagnostic error code.

Universal Serial Bus (USB) Test

At the advanced diagnostic test menu, connect the USB parallel test cable (P/N 05K2580) to the computer. Click on the USB icon to run the test. Follow the instructions on the screen. **OK** appears if the test passes and three lines of error codes appear if the test fails. The defective FRU must be the DC/DC card or the system board.

Use cable number 2 for an external USB port on the port replicator.

Displaying the Error Log

Diagnostic errors are printed on a printer that is attached to the parallel port when the error is detected. The error is also logged in the system memory.

Use the following procedures to display the errors:

- Enter the advanced diagnostic test.
- Press **Ctrl+E**.
- The error log appears.
- To exit the window, click on **Exit** or press **Esc** key.

The error log is not saved when the system power is turned off.

Checking the Installed Devices List

If a device is installed but its icon appears in gray shade rather than in dark shade on the basic diagnostics test menu, the device is defective. Reseat the device connectors. If the symptom remains, replace the device or the system board. If needed, adjust the contrast control to clearly distinguish the shades of the icon.

If a device that is not installed appears in dark shade (for example, FDD-2 appears in dark shade when *no* second FDD is installed), do the following:

1. Replace the **first** device in the configuration, such as an FDD-1.
2. If the problem persists, replace the system board.

The Parallel, and Serial icons are always displayed in dark shade, because the icons represent subsystems of the system board, not the attachment of devices.

The FDD-1 icon represents the **first** drive in the system configuration for each type of device. The FDD-2 icon represents the **second** drive, attached through a port replicator.

Diagnostic Error Codes

If an error is detected, the following appears:

- Large **X** on the left side of the device icon.
- Device ID (three digits)
- Error code (two digits)
- FRU code (four digits)







For example:











 SystemBoard
 DEV 001
 ERR 02
 FRU 0010

The device ID and error code indicate the detailed portion of the FRU that caused the error. If replacing a FRU does not correct the problem, see the device ID or error code from the previous failure. If they changed, the new FRU might be defective, or it may have been incorrectly installed.

Device ID: If an error is detected by the diagnostic tests, a three-digit device ID is displayed, indicating the suspected device.

Icon	Device ID	Suspected Device
 SystemBoard	001	System board
	003	Keyboard
	007	Math coprocessor
	086	Pointing device
 Memory	002	Memory
 Display	050	Display
	054	
 HDD	017	Hard disk drive
1  FDD-1	006	Built-in FDD
2  FDD-2	066	1. External diskette drive 2. FDD connector of the port replicator
1  PCMCIA-1	080	1. PC card slot connector 2. PC Card

Icon	Device ID	Suspected Device
 PCMCIA-2	088	External PC Card
 Parallel	009	Parallel
 Serial	011	Serial
 CDROM	215	CD-ROM
 Infrared	103	IR
 Audio	153	Audio (Crystal)
 USB-1	154	USB port
 USB-2	155	USB port of the port replicator

FRU Codes: If an error is detected by the diagnostic tests, a four-digit FRU code is displayed. The FRU code indicates two suspected FRUs. Replace the FRU that is indicated by the **two leftmost digits** first; then replace the FRU that is indicated by the **two rightmost digits**. No FRU is assigned to code 00. If only one FRU is suspected, the other FRU code digits are filled with zeros. See the reference page before replacing the FRU.

FRU Code	FRU
10	System board
11	CPU Card
12	DC/DC card
20	Memory (see "Memory Checkout" on page 28)
30	Reserved
32	External keyboard
33	External mouse
34	AC Adapter

FRU Code	FRU
35	Speaker
36	Battery in the battery bay
38	Fan
40	LCD unit
45	External monitor
50	<ol style="list-style-type: none"> 1. Reseat the diskette drive (FDD-1). 2. Reseat the external FDD cable on the video card. 3. Diskette drive (FDD-1)
51	<ol style="list-style-type: none"> 1. Reseat the diskette drive (FDD-2). 2. Diskette drive (FDD-2)
60	<ol style="list-style-type: none"> 1. Reseat the hard disk drive (HDD). 2. Hard disk drive (HDD)
70	PCMCIA-2 (replicator)
72	<ol style="list-style-type: none"> 1. Reseat the PC card slot assembly 2. PC Card slot assembly
73	Port replicator

Note: The device ID and error codes are used to indicate the detailed portion of the FRU that is causing the error. If replacing a FRU does not correct the problem, see the device ID or error code from the previous failure. If they changed, the new FRU might be defective, or it may have been incorrectly installed.

If the problem persists even after the FRUs are replaced, go to “Undetermined Problems” on page 48.

Related Service Procedures





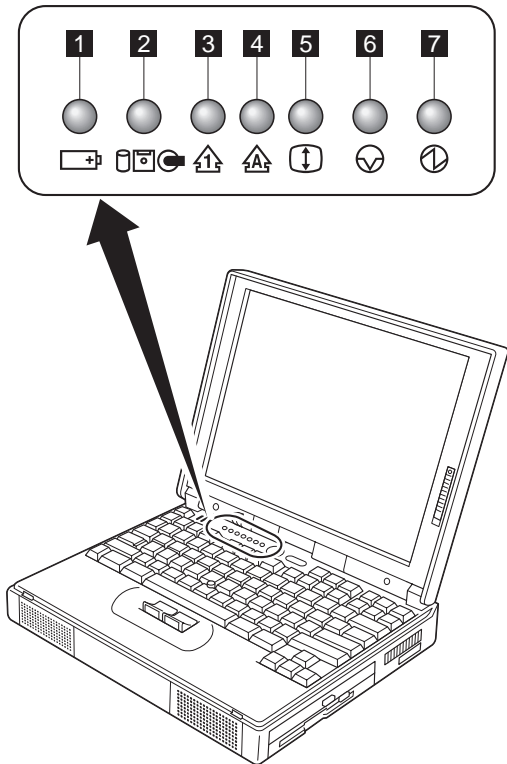

This section provides information on the following:

- “Status Indicators”
- “Password Combinations” on page 56
- “Running a Low-Level Format” on page 57
- “Maintenance Diskette Download” on page 57
- “Fn Key Combinations” on page 57

Status Indicators

The status indicators show the current computer status in different colors (green and orange):



Symbol	Color	Meaning
1 Battery 	Green	The battery is fully charged.
	Orange	The battery is charging.
	Blinking orange	The battery needs charging.
2 Hard Disk In Use 	Orange	Data is read from or written to the hard disk, diskette, or CD-ROM.
3 Numeric Lock 	Green	The numeric keypad on the keyboard is enabled.
4 Caps Lock 	Green	Caps Lock mode is enabled.
5 Scroll Lock 	Green	Arrow keys can be used as screen-scroll function keys.
6 Suspend Mode 	Green	Suspend mode
	Blinking Green	Entering suspend mode or hibernation mode, or reusing normal operation.
7 Power On 	Green	Power on

Password Combinations

The Model 380XD or 385XD supports the following passwords:

- Power-on password (POP)
- Hard disk password (HDP)
- Supervisor password (PAP)

The password combinations are:

- When the **POP** is the same as one of the **HDPs** (HDP-1 or HDP-2), a POP prompt and an HDP prompt with different passwords appear.
- When the **POP** is not the same as any of the
- When the **PAP** is used, the **HDP-1** or the **HDP-2** is automatically enabled but the HDP prompt does not appear. The HDP-1 and HDP-2 are then set to the same password as the PAP.

Running a Low-Level Format

Attention: Make sure the drive address to be formatted is correct. This procedure erases all information on the disk.

Do the following to format the hard disk:

1. Turn off the computer.
2. Insert the **ThinkPad Hardware Maintenance Diskette Ver 1.40** or later into diskette drive **A** and turn on the computer.
3. Select **Format the hard disk** from the main menu.
4. Select the drive from the menu.
5. Follow the instructions on the screen.

Maintenance Diskette Download

You cannot get the maintenance diskette from the parts center, but you can download from the IBM internal web site.

The following is the URL of the IBM internal Web site:

<http://pccbbs.raleigh.ibm.com/>

Fn Key Combinations

The following table shows the **Fn** key and function key combinations and their corresponding functions.

The **Fn** key works independently from the operating system. The operating system obtains the status through the system management interface to control the system.

Fn +	Description
F1	Reserved
F2	Fuel-Gauge monitor on or off
F3	Standby mode invocation
F4	Suspend mode invocation
F5	Reserved
F6	Reserved
F7	Switching between the LCD and an external monitor
F8	Switching between the screen expansion is on and off (no symbol on the key)
F9	Reserved
F10	Reserved
F11	Switching the power management mode (High Performance, Automatic, and Customized)
F12	Hibernation invocation

FRU Removals and Replacements

This section contains information about removals and replacements.

- Do not damage any FRUs. Only certified and trained personnel should service the computer.
- The arrows in the “Removals and Replacements” section show the direction of movement to remove a FRU, or to turn a screw to release the FRU. The arrows are marked in numeric order, in square callouts, to show the correct sequence of removal.
- When other FRUs must be removed before the failing FRU is removed, they are listed in that order.
- To replace a FRU, reverse the removal procedure and follow any notes that pertain to replacement. See “Locations” for internal cable connections and arrangement information.
- When replacing a FRU, use the correct screw size as shown in the procedures.

Safety Notice 1: Translation on page 5

Before the computer is powered-on after FRU replacement, make sure all screws, springs, or other small parts, are in place and are not left loose inside the computer. Verify this by shaking the computer and listening for rattling sounds. Metallic parts or metal flakes can cause electrical short circuits.

Safety Notice 4: Translation on page 8

The lithium battery can cause a fire, explosion, or severe burn. Do not recharge it, remove its polarized connector, disassemble it, heat it above 100°C (212°F), incinerate it, or expose its cell contents to water. Dispose of the battery as required by local ordinances or regulations. Use only the battery in the appropriate parts listing. Use of an incorrect battery can result in ignition or explosion of the battery.

Safety Notice 8: Translation on page 11

Before removing any FRU, power-off the computer, unplug all power cords from electrical outlets, remove the battery pack, and then disconnect any interconnecting cables.

Attention: The system board is sensitive to, and can be damaged by, electrostatic discharge. Establish personal grounding by touching a ground point with one hand before touching these units. Use an electrostatic discharge (ESD) strap (P/N 6405959) to establish personal grounding.

Important Notice

This machine uses special nylon-coated screws with the following characteristics:

- They maintain tight connection.
- They do not easily come loose, even with shock or vibration.

But:

- They need additional force to tighten.
- They should not be reused.

Do the following when you service this machine:

- Keep the screw kit (P/N 12J0808) in your tool bag.
- Always use new screws.
- Use a torque screwdriver if you have one.

Screw Tightening Information: Loose screws can cause a reliability problem. The IBM ThinkPad computer addresses this problem with nylon-coated screws. Tighten screws as follows:

- **Plastic to plastic**

Turn an additional **90 degrees** after the screw head touches the surface of the plastic part:

90 degrees more

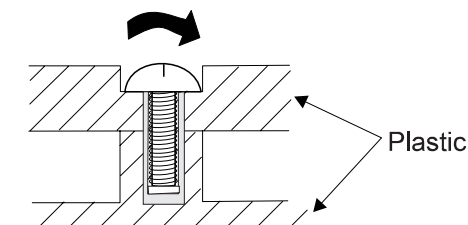

- **Logic card to plastic**

Turn an additional **180 degrees** after the screw head touches the surface of the logic card:

180 degrees more

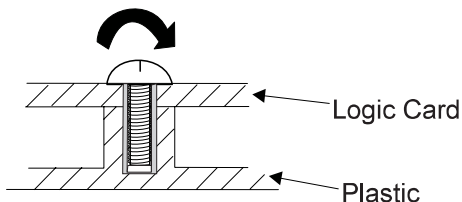

- **Torque driver**

If you have a torque driver, refer to the "Torque" instructions with each step.

FRU Service Procedure

Review the following procedures before replacing any FRUs.

Replacing the System Board: The EEPROM on the system board contains the valid product data (VPD)—that is, a system unit serial number and a system board serial number. When you replace the system board, restore the system unit serial number using the **Set system identification** utility in the ThinkPad hardware maintenance diskette. The serial number label is attached to the computer.

Note: Do not power off the computer while restoring the VPD.

Removal Reference

Refer to the following chart for the removal order:

Ref. No.	FRU	Page No.
1010	DIMM Card and Backup Battery	62
1020	Battery Pack	63
1030	Hard Disk Drive	64
1040	Keyboard Unit	66
1050	Keyboard and Speaker	69
1060	CD-ROM Drive and Diskette Drive Assembly	71
1070	Diskette Drive and Diskette Drive Assembly	72
1080	LCD Unit	76
1090	Fan Assembly, CPU Card, and Thermal Rubber	79
1100	Upper Shield Case	82
1110	Box Speaker and Microphone	83
1120	DC/DC Card	85
1130	System Board and PC Card Slot	87
1140	Battery Pack Latch	90
2010	LCD Front Cover	91
2020	LCD Panel	93
2030	LCD Inverter Card	97
2040	LCD Misc. Parts	99
2050	LCD Cable	103

1010 DIMM Card and Backup Battery

Safety Notice 4: Translation on page 8

The lithium battery can cause a fire, explosion, or severe burn. Do not recharge it, remove its polarized connector, disassemble it, heat it above 100°C (212°F), incinerate it, or expose its cell contents to water. Dispose of the battery as required by local ordinances or regulations. Use only the battery in the appropriate parts listing. Use of an incorrect battery can result in ignition or explosion of the battery.

1 Turn the computer upside down.

2 3 4 5 6 : DIMM
2 3 7 : Backup battery

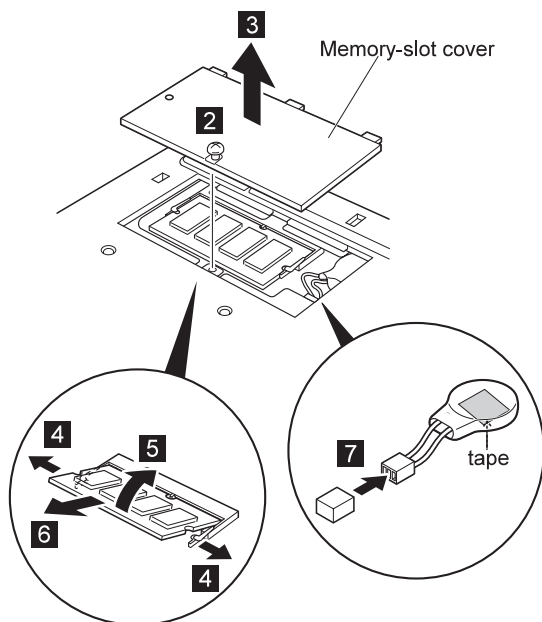

When installing:

When installing a new backup battery, place it where the old one was on the printed circuit board (system board) with double-sided adhesive tape.

Step	Size (Quantity)	Torque
2	—	3-4 kgcm

Note: You can loosen the screw in step **2**, but cannot remove it.

1020 Battery Pack

1 Turn the computer upside down.

Pull up the battery pack lock **2**, push it back **3**, and then pull up the battery pack **4**.

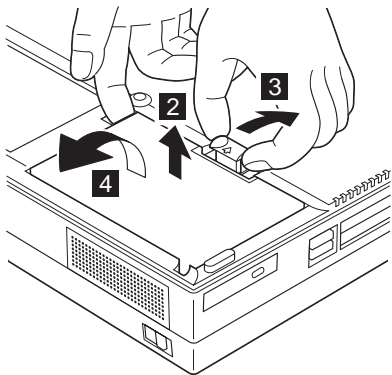

1030 Hard Disk Drive

Warning

Do not drop or apply any shock to the hard disk drive. The hard disk drive is sensitive to physical shock. Incorrect handling can cause damage and permanent loss of data on the hard disk. Before removing the hard disk drive, have the user make a backup copy of all the information on the hard disk. Never remove the hard disk drive while the system is operating or is in suspend mode.

- Battery Pack (1020)

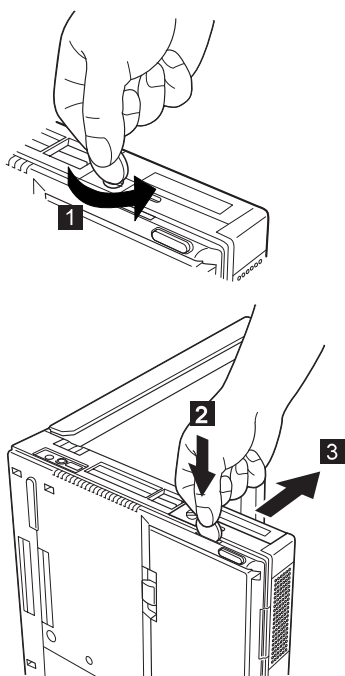

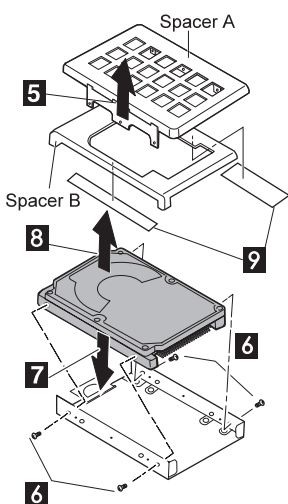
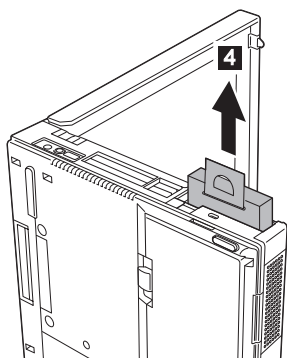

Information on spacers

The relation between the thickness of the HDD and the spacers is as follows:

12.5 mm	Spacer
17 mm	None

Step	Size (Quantity)	Torque
6	M 3 x 2.8 mm, Flathead (4)	3-4 kgcm

Note: Make sure you use the correct screw, and tighten all screws firmly to the torque shown in the table if you have a torque screwdriver. **Never use a screw that you removed. Use a new one. Make sure the screws are tightened firmly.**

1040 Keyboard Unit

- Battery Pack (1020)

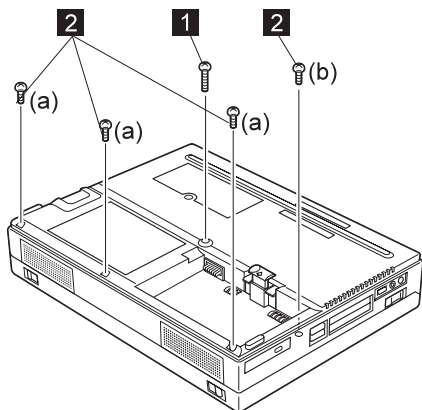

Step	Size (Quantity)	Torque
1	M 2.5 x 25 mm, nylon-coated (1)	3-4 kgcm
2	(a) M 2.5 x 8 mm, nylon-coated (3) (b) M 2.5 x 6 mm, nylon-coated (1)	3-4 kgcm

Note: Make sure you use the correct screw, and tighten all screws firmly to the torque shown in the table if you have a torque screwdriver. **Never use a screw that you removed. Use a new one. Make sure the screws are tightened firmly.**

- 3** Make sure that the battery pack lock is not sticking out, and turn the computer right side up.

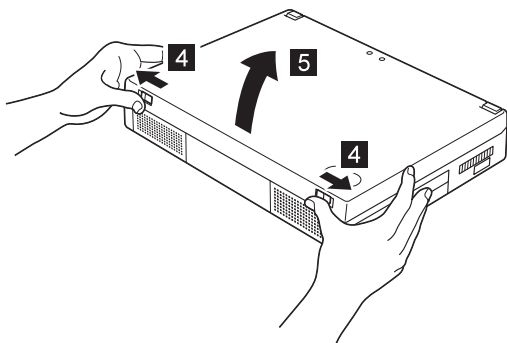

Note: In order not to damage the connectors, pull the keyboard assembly toward you a **little** in step **7**, and then go to step **8**.

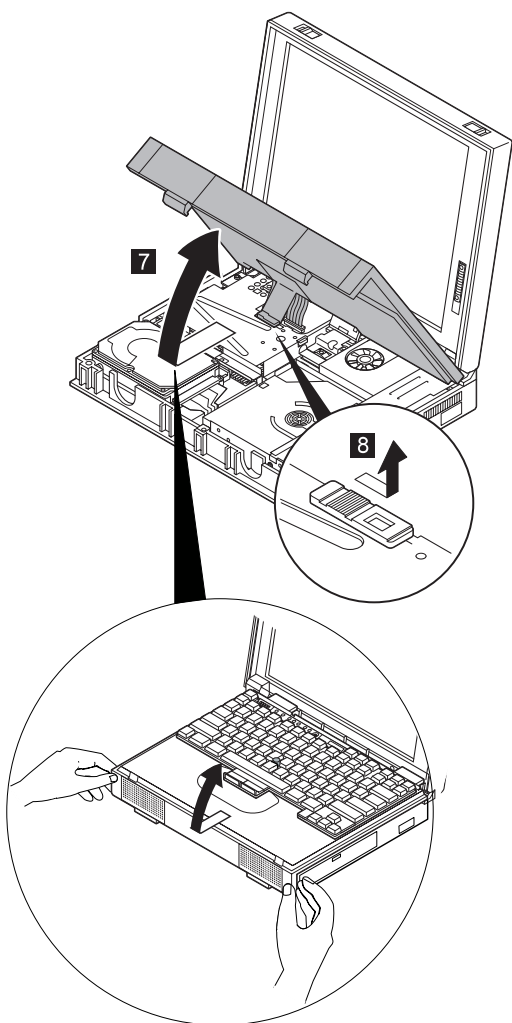

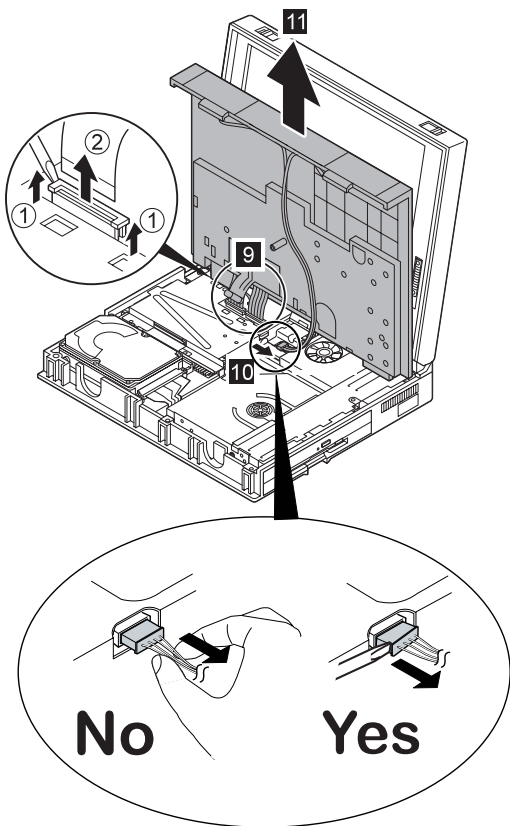

When installing

See the following figure for the direction of the speaker connector:

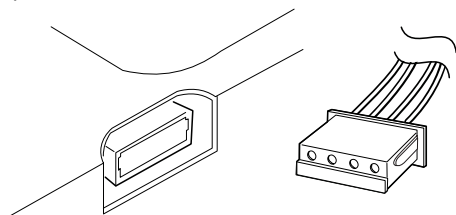

When replacing

Apply a model name label on the keyboard.

1050 Keyboard and Speaker

- Battery Pack (1020)
- Keyboard Unit (1040)

Important: When you release **latch B**, be careful not to apply any force to area **A** (lenses for status indicators).

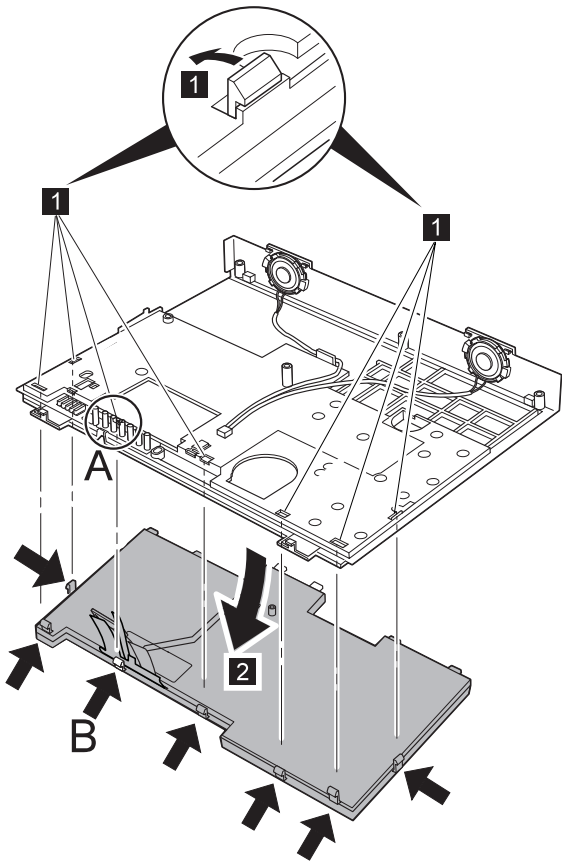

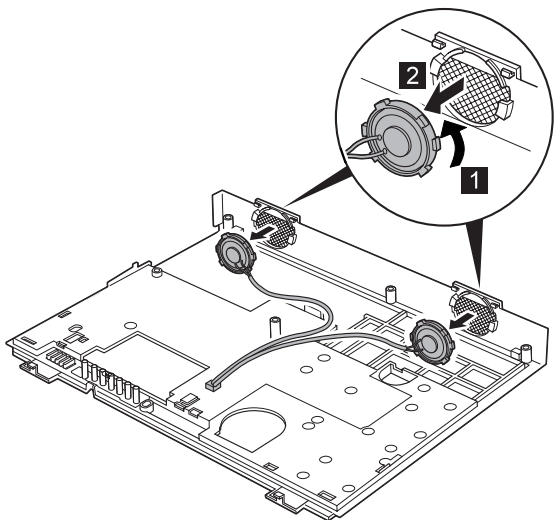

When installing

The following figure shows the route for the speaker cables.

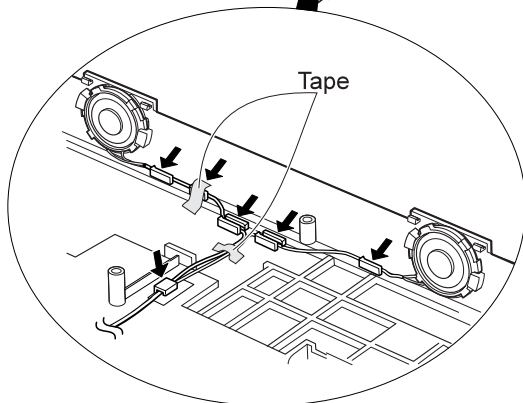
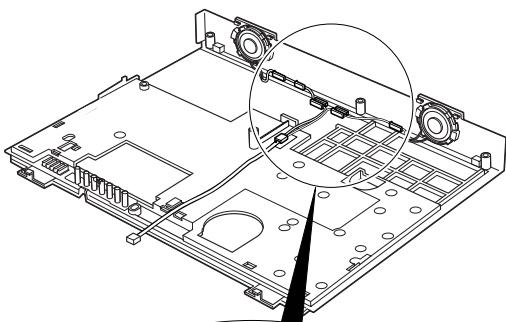

1060 CD-ROM Drive and Diskette Drive Assembly

- Battery Pack (1020)
- Keyboard Unit (1040)

Note: Be careful that the computer does not fall backward when you remove the CD-ROM and diskette drive assembly.

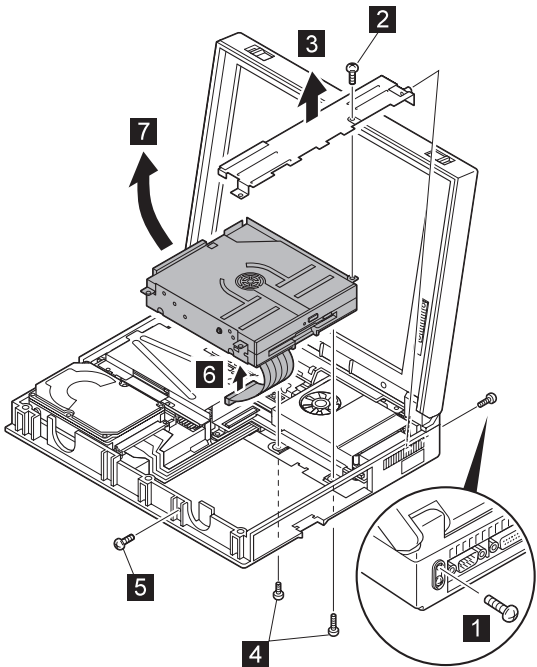

Step	Size (Quantity)	Torque
1	M 2.5 x 6 mm, nylon-coated (1)	3-4 kgcm
2	M 2.5 x 6 mm, nylon-coated (1)	3-4 kgcm
4	M 2.5 x 8 mm, nylon-coated (2)	3-4 kgcm
5	M 2.5 x 6 mm, nylon-coated (1)	3-4 kgcm

Note: Make sure you use the correct screw, and tighten all screws firmly to the torque shown in the table if you have a torque screwdriver. **Never use a screw that you removed. Use a new one. Make sure the screws are tightened firmly.**

1070 Diskette Drive and CD-ROM Drive

- Battery Pack (1020)
- Keyboard Unit (1040)
- CD-ROM and Diskette Drive Assembly (1060)

Note: When replacing, be sure to firmly tighten the pink and yellow screws.

Diskette Drive

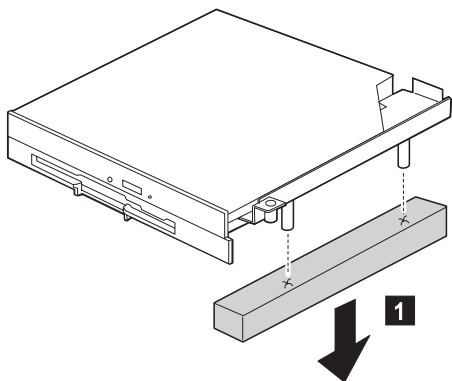

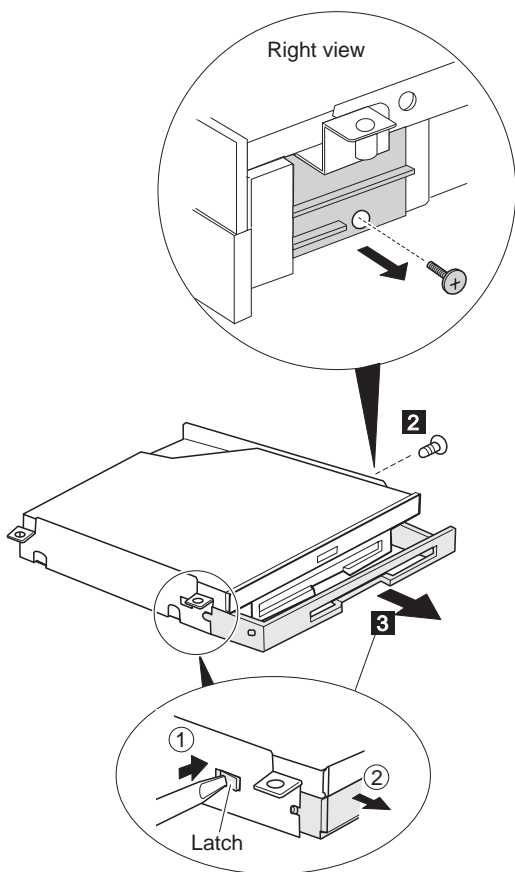

Step	Size (Quantity)	Torque
2	M 2.6 x 4 mm Yellow (1)	4 kgcm
<p>Note: Make sure you use the correct screw, and tighten all screws firmly to the torque shown in the table if you have a torque screwdriver. Never use a screw that you removed. Use a new one. Make sure the screws are tightened firmly.</p>		

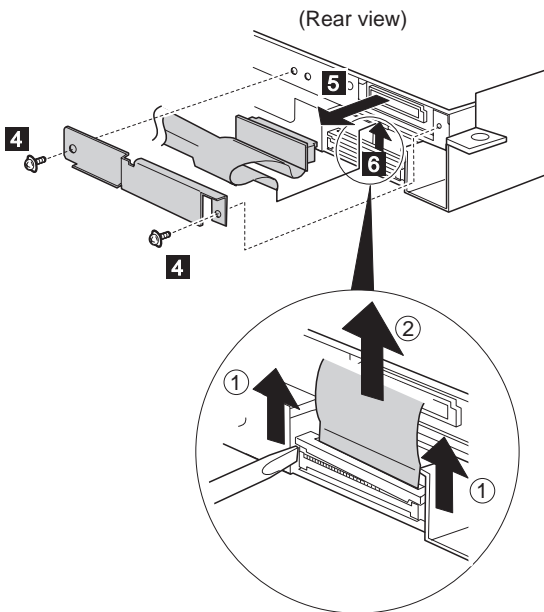

Step	Size (Quantity)	Torque
4	M 2 x 1.7 mm, special-head, Blue (2)	1.5-1.8 kgcm

Note: Make sure you use the correct screw, and tighten all screws firmly to the torque shown in the table if you have a torque screwdriver. **Never use a screw that you removed. Use a new one. Make sure the screws are tightened firmly.**

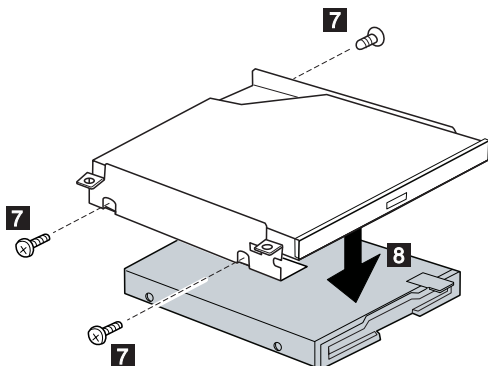

Step	Size (Quantity)	Torque
7	M 2.6 x 2.8 mm pink (3)	4 kgcm
<p>Note: Make sure you use the correct screw, and tighten all screws firmly to the torque shown in the table if you have a torque screwdriver. Never use a screw that you removed. Use a new one. Make sure the screws are tightened firmly.</p>		

10X - 24X CD-ROM (05K8868)

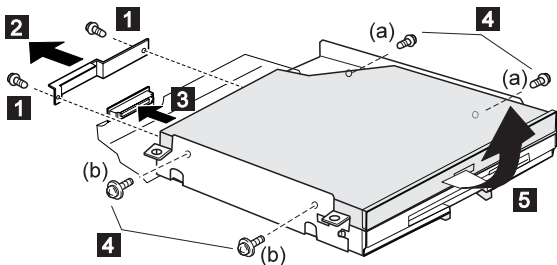

Step	Size (Quantity)	Torque
1	M 2 x 1.7 mm, special-head, blue (2)	1.5-1.8 kgcm
4	(a) M 2 x 1.7 mm, special-head, blue (2) (b) M 2 x 2.4 mm, special-head, yellow (2)	1.5-1.8 kgcm
<p>Note: Make sure you use the correct screw, and tighten all screws firmly to the torque shown in the table if you have a torque screwdriver. Never use a screw that you removed. Use a new one. Make sure the screws are tightened firmly.</p>		

1080 LCD Unit

- Battery Pack (1020)
- Keyboard Unit (1040)

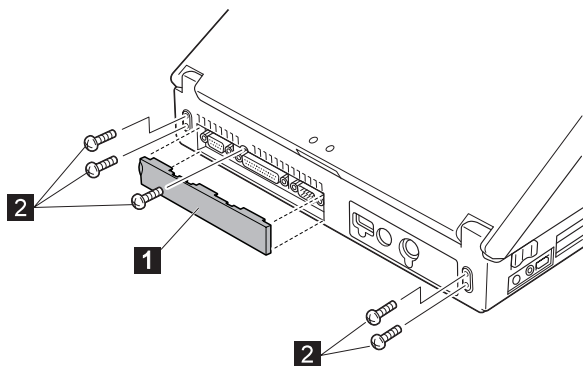

Step	Size (Quantity)	Torque
2	M 2.5 x 6 mm, nylon-coated (5)	3-4 kgcm
Note: Make sure you use the correct screw, and tighten all screws firmly to the torque shown in the table if you have a torque screwdriver. Never use a screw that you removed. Use a new one. Make sure the screws are tightened firmly.		

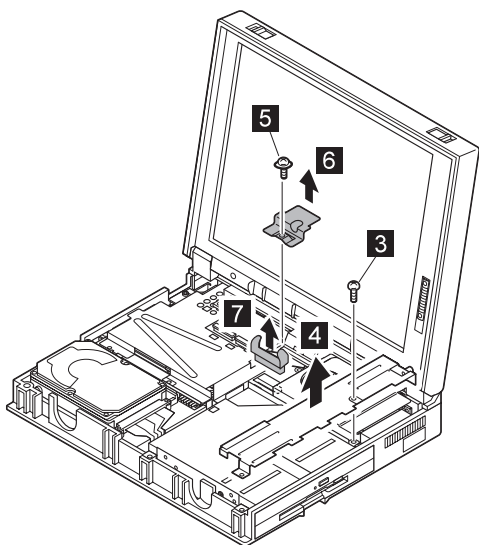

Step	Size (Quantity)	Torque
3	M 2.5 x 6 mm, nylon-coated (1)	3-4 kgcm
5	M 2.5 x 6 mm, special-head (1)	3 kgcm

Note: Make sure you use the correct screw, and tighten all screws firmly to the torque shown in the table if you have a torque screwdriver. **Never use a screw that you removed. Use a new one. Make sure the screws are tightened firmly.**

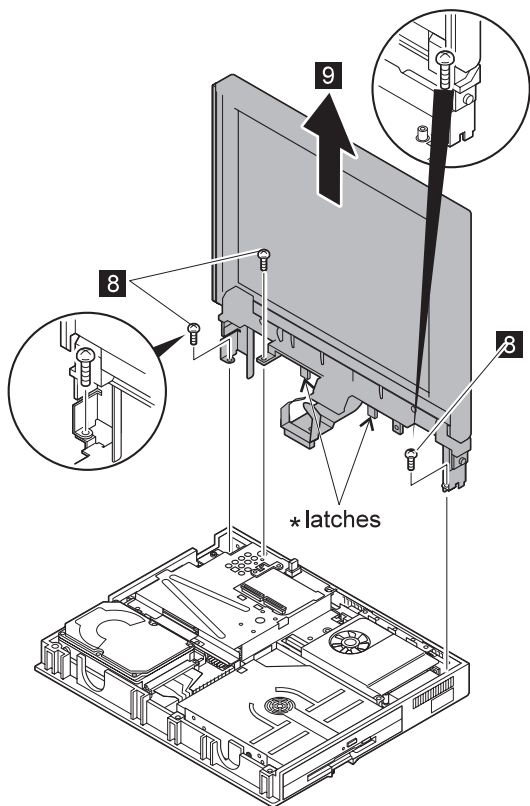

* When removing the LCD, be careful not to damage the latches.

Step	Size (Quantity)	Torque
8	M 2.5 x 6 mm, nylon-coated (3)	3-4 kgcm
<p>Note: Make sure you use the correct screw, and tighten all screws firmly to the torque shown in the table if you have a torque screwdriver. Never use a screw that you removed. Use a new one. Make sure the screws are tightened firmly.</p>		

1090 Fan Assembly, CPU Card, Thermal Rubber

- Battery Pack (1020)
- Keyboard Unit (1040)
- CD-ROM and Diskette Drive Assembly (1060)
- LCD Unit (1080)

Attention:

When removing, be careful not to damage the CPU card.

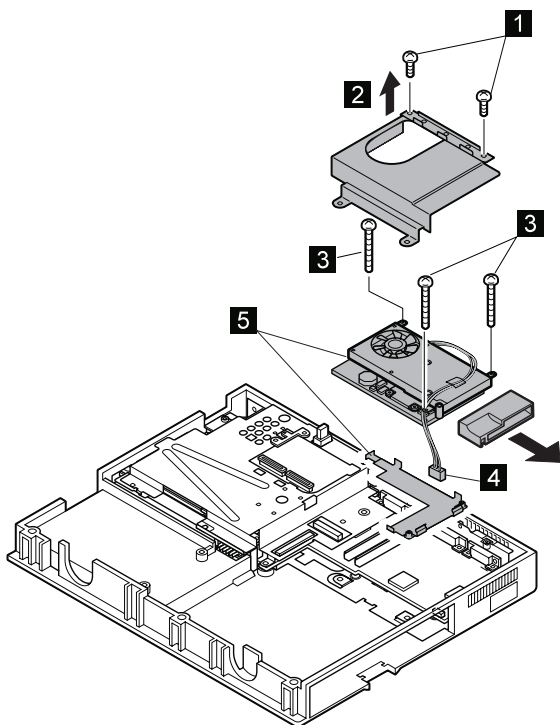

Step	Size (Quantity)	Torque
1	M 2 x 6 mm, nylon-coated (2)	2-3 kgcm
3	M 2 x 18 mm, nylon-coated (3)	2-3 kgcm

Note: Make sure you use the correct screw, and tighten all screws firmly to the torque shown in the table if you have a torque screwdriver. **Never use a screw that you removed. Use a new one. Make sure the screws are tightened firmly.**

2635-8xx/9xx/Axx/Bxx

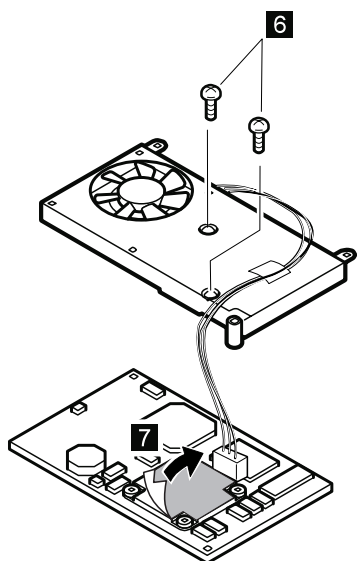

2635-Dxx/Exx/Fxx

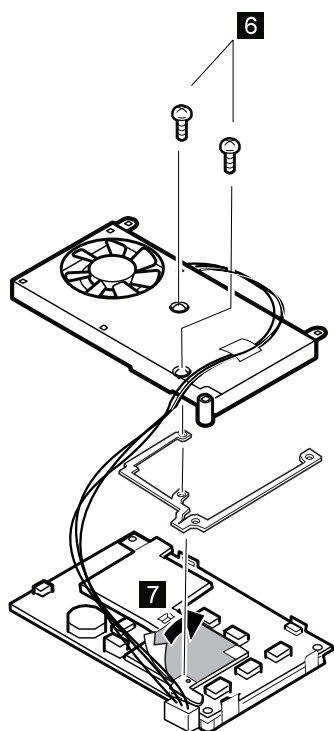

Step	Size (Quantity)	Torque
6	M 2 x 6 mm, nylon-coated (2)	2-3 kgcm
<p>Note: Make sure you use the correct screw, and tighten all screws firmly to the torque shown in the table if you have a torque screwdriver. Never use a screw that you removed. Use a new one. Make sure the screws are tightened firmly.</p>		

When installing

- Make sure the connectors are fitted firmly by **pressing the corners of the card.**

2635-8xx/9xx/Axx/Bxx

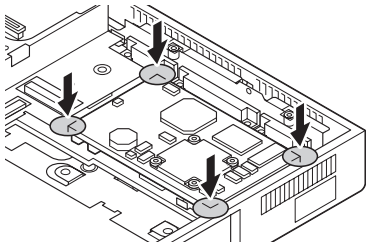

2635-Dxx/Exx/Fxx

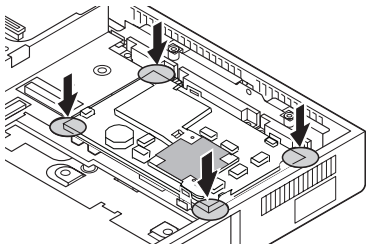

A loose connection or a damaged card causes a power failure.

- The following figure shows the route of the fan assembly cables:

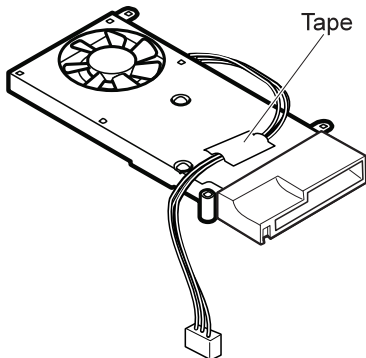

1100 Upper Shield Case

- Battery Pack (1020)
- Keyboard Unit (1040)
- CD-ROM/Diskette Drive Assembly (1060)
- LCD Unit (1080)

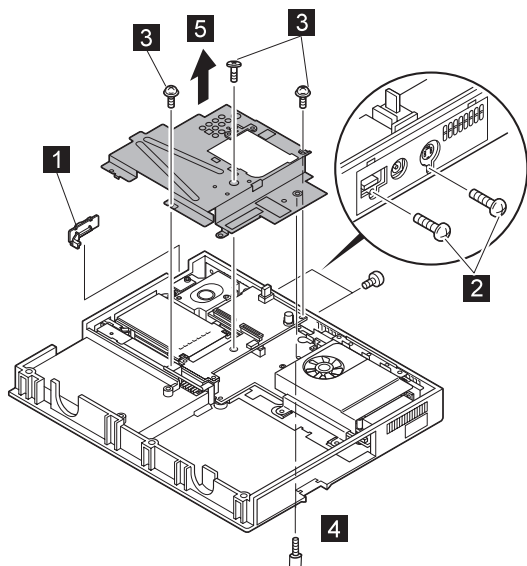

Step	Size (Quantity)	Torque
2	M 2.5 x 8 mm, nylon-coated (2)	3-4 kgcm
3	M 2.5 x 6 mm, nylon-coated (3)	3-4 kgcm
4	M 2.5 x 6 mm, bighead (1)	3-4 kgcm

Note: Make sure you use the correct screw, and tighten all screws firmly to the torque shown in the table if you have a torque screwdriver. **Never use a screw that you removed. Use a new one. Make sure the screws are tightened firmly.**

1110 Box Speaker and Microphone

- Battery Pack (1020)
- Keyboard Unit (1040)
- CD-ROM and Diskette Drive Assembly (1060)
- LCD Unit (1080)
- Upper Shield Case (1100)

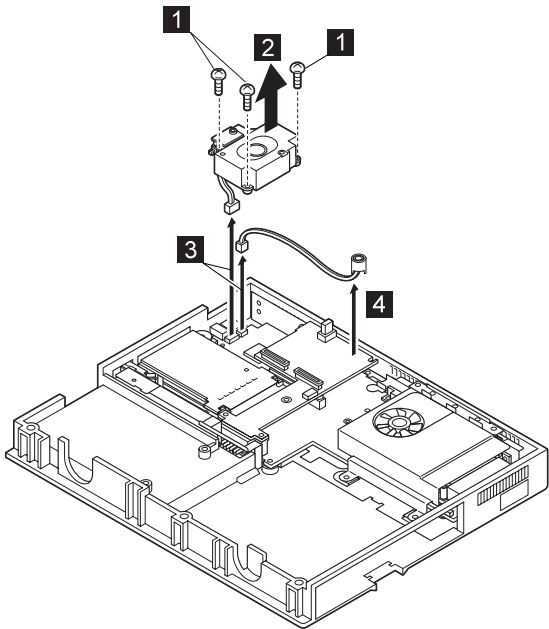

Step	Size (Quantity)	Torque
1	M 2.5 x 12 mm, nylon-coated (3)	3-4 kgcm
Note: Make sure you use the correct screw, and tighten all screws firmly to the torque shown in the table if you have a torque screwdriver. Never use a screw that you removed. Use a new one. Make sure the screws are tightened firmly.		

When installing

The following figure shows the route for the microphone and speaker cables:

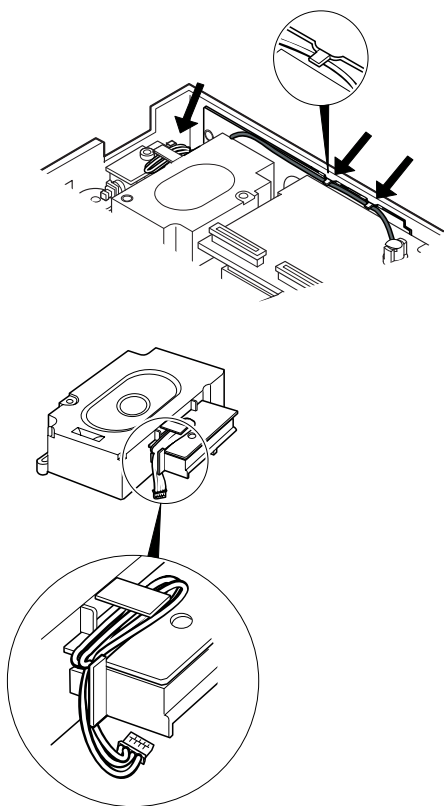

1120 DC/DC Card

- Battery Pack (1020)
- Keyboard Unit (1040)
- CD-ROM and Diskette Drive Assembly (1060)
- LCD Unit (1080)
- Upper Shield Case (1100)

Pay attention that the **connectors** tend to be caught in the base cover.

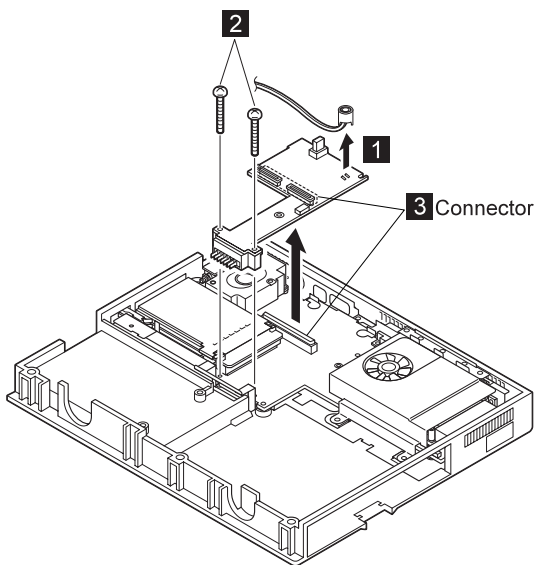

Step	Size (Quantity)	Torque
2	M 2.5 x 22 mm, nylon-coated (2)	3-4 kgcm
Note: Make sure you use the correct screw, and tighten all screws firmly to the torque shown in the table if you have a torque screwdriver. Never use a screw that you removed. Use a new one. Make sure the screws are tightened firmly.		

When installing

The following figure shows the route for the microphone cable:

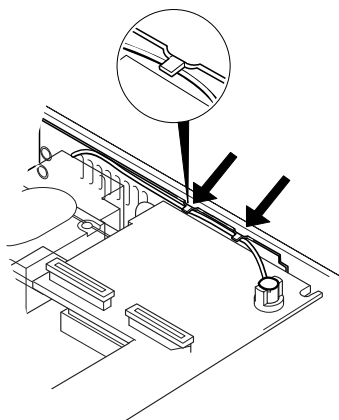

1130 System Board and PC Card Slot

1. The system unit serial number must be restored when the system board is replaced. To restore the system unit serial number, select the option "Set system identification" on the maintenance diskette. The flash ROM on the system board contains the vital product data (VPD)—that is, the system unit serial number, system board serial number, and other computer-unique data.
 2. Do not turn off the computer while restoring the VPD. The system unit serial number label is attached to the base cover.
 3. Before removing and replacing the system board assembly, make sure that the PC Cards are removed and the eject buttons are not sticking out. If the PC Card eject buttons are sticking out, pull them further out slightly and fold them to the right; then push up the system board assembly from the bottom.
- Battery Pack (1020)
 - Keyboard Unit (1040)
 - CD-ROM and Diskette Drive Assembly (1060)
 - LCD Unit (1080)
 - Fan Assembly/CPU Card (1090)
 - Upper Shield Case (1100)

Pay attention to the **connectors** that tend to catch in the cover.

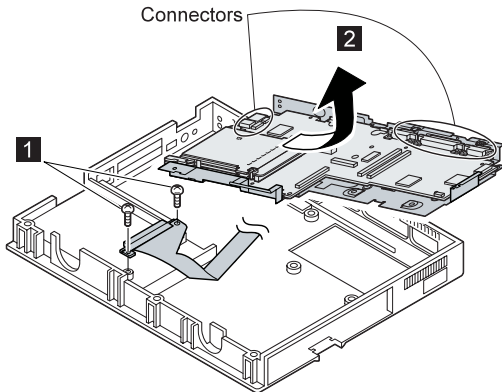

Step	Size (Quantity)	Torque
1	M 2.5 x 6 mm, nylon-coated (2)	3-4 kgcm

Note: Make sure you use the correct screw, and tighten all screws firmly to the torque shown in the table if you have a torque screwdriver. **Never use a screw that you removed. Use a new one. Make sure the screws are tightened firmly.**

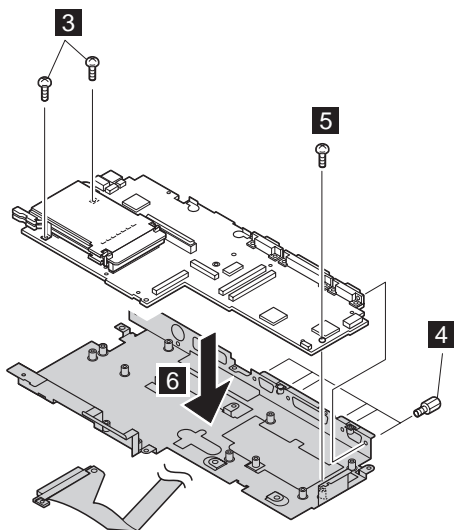

Step	Size (Quantity)	Torque
3	M 2.5 x 6 mm, nylon-coated (2)	3-4 kgcm
4	Hex stud screw (6)	3-4 kgcm
5	M 2.5 x 6 mm, nylon-coated (1)	3-4 kgcm
<p>Note: Make sure you use the correct screw, and tighten all screws firmly to the torque shown in the table if you have a torque screwdriver. Never use a screw that you removed. Use a new one. Make sure the screws are tightened firmly.</p>		

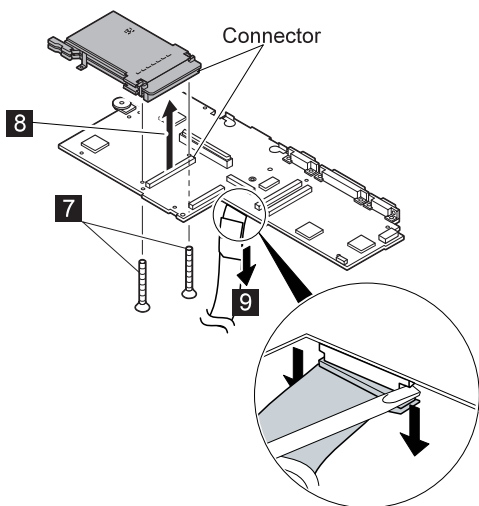

Step	Size (Quantity)	Torque
7	M 2 x 18 mm, nylon-coated (2)	2-3 kgcm
<p>Note: Make sure you use the correct screw, and tighten all screws firmly to the torque shown in the table if you have a torque screwdriver. Never use a screw that you removed. Use a new one. Make sure the screws are tightened firmly.</p>		

1140 Battery Pack Latch

- Battery Pack (1020)
- Keyboard Unit (1040)
- CD-ROM and Diskette Drive Assembly (1060)
- LCD Unit (1080)
- Fan Assembly/CPU Card (1090)
- Upper Shield Case (1100)
- System Board and PC Card Slot (1130)

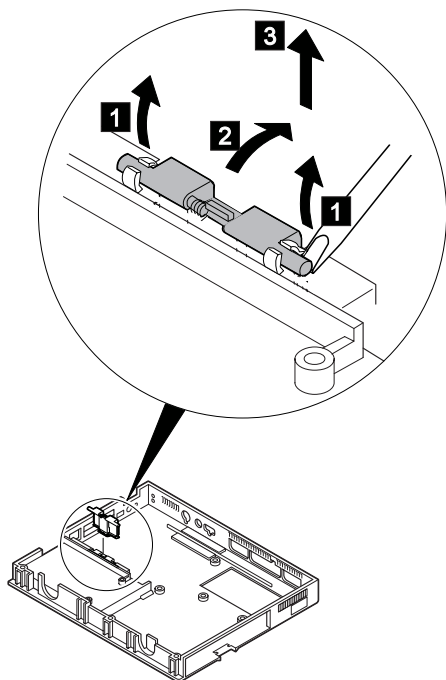

2010 LCD Front Cover

- Memory-slot Cover (DIMM Card) **(1010)**
- Battery Pack **(1020)**
- Keyboard Unit **(1040)**
- LCD Unit **(1080)**

1 2 3 : LCD Front Cover
4 : Control Knob

Notes:

1. The LCD front cover has several latches. Release the latches as shown in the figure in step **3**.
2. When replacing the control knob in step **4**, make sure that it works correctly.

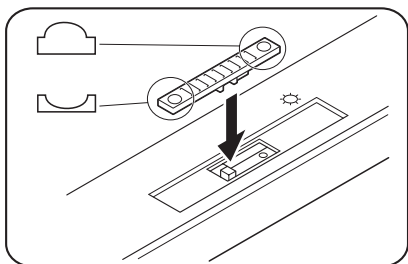

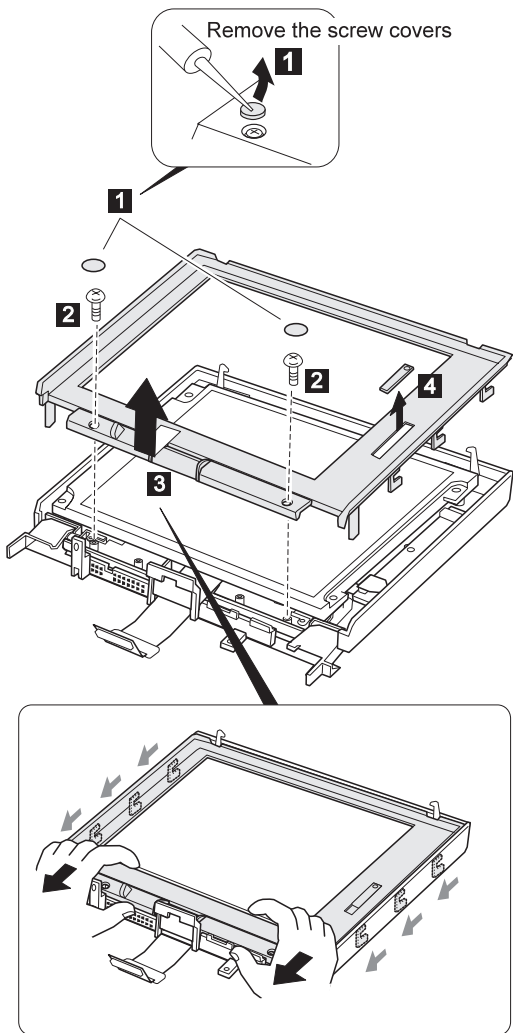

Step	Size (Quantity)	Torque
2	M 2.5 x 6 mm, nylon-coated(2)	3-4 kgcm
<p>Note: Make sure you use the correct screw, and tighten all screws firmly to the torque shown in the table if you have a torque screwdriver. Never use a screw that you removed. Use a new one. Make sure the screws are tightened firmly.</p>		

2020 LCD Panel

- Memory-slot Cover (DIMM Card) **(1010)**
- Battery Pack **(1020)**
- Keyboard Unit **(1040)**
- LCD Unit **(1080)**
- LCD Front Cover **(2010)**

Note on LCD identification

You can distinguish between HPA LCD, TFT LCD type 1, and TFT LCD type 2 by the label on the LCD cable:

HPA LCD: 05K9309 or 05K9320

TFT LCD Type 1: 05K9312 or 05K9322

TFT LCD Type 2: 05K9311 or 05K9321

HPA LCD Panel

(Labeled 05K9309 or 05K9320)

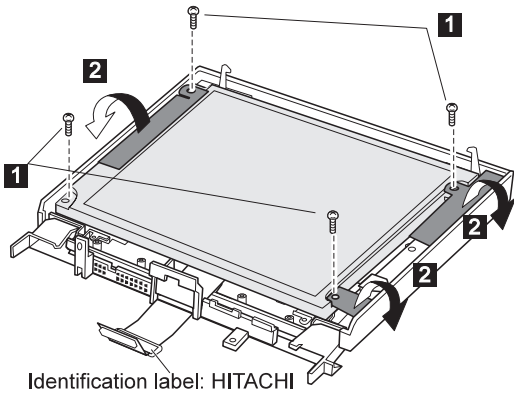

Note: In step **4** , lift the LCD panel slightly to disconnect the flexible cable in step **5** .

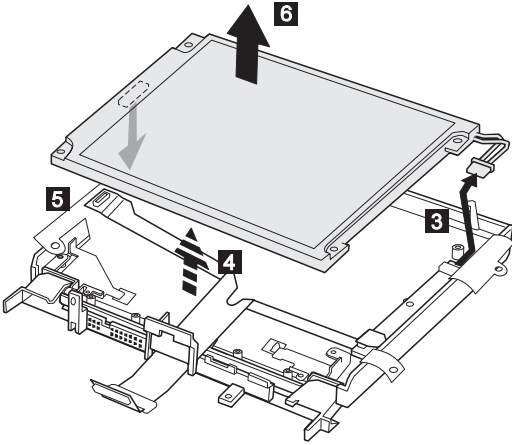

Step	Size (Quantity)	Torque
1	M 2.5 x 6 mm, nylon-coated(4)	3-4 kgcm
Note: Make sure you use the correct screw, and tighten all screws firmly to the torque shown in the table if you have a torque screwdriver. Never use a screw that you removed. Use a new one. Make sure the screws are tightened firmly.		

TFT LCD Panel

Note on TFT LCD identification

You can distinguish between HPA LCD, TFT LCD type 1 and type 2 by the label on the LCD cable. The labels are said as follows.

HPA LCD: 05K9309 or 05K9320

TFT LCD Type 1: 05K9312 or 05K9322

TFT LCD Type 2: 05K9311 or 05K9321

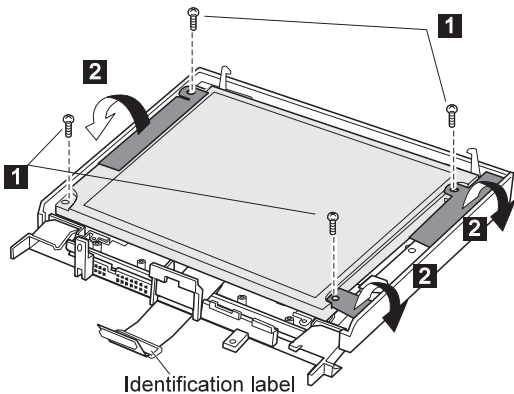

Step	Size (Quantity)	Torque
1	M 2.5 x 6 mm, nylon-coated (4)	3-4 kgcm
Note: Make sure you use the correct screw, and tighten all screws firmly to the torque shown in the table if you have a torque screwdriver. Never use a screw that you removed. Use a new one. Make sure the screws are tightened firmly.		

Type 1 (Labeled 05K9312 or 05K9322)

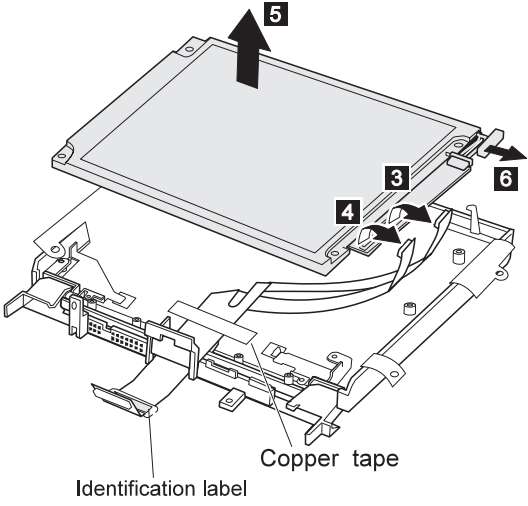

Type 2 (Labeled 05K9311 or 05K9321)

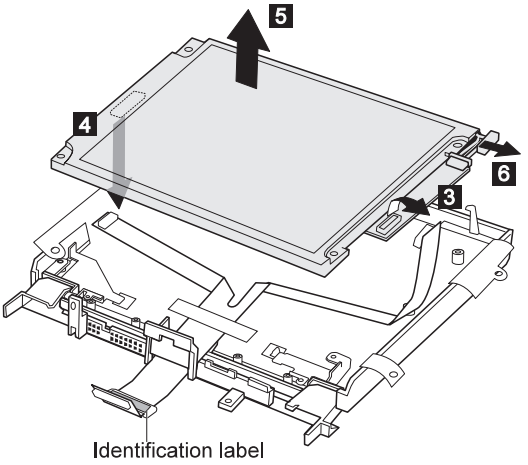

2030 LCD Inverter Card

- Memory-slot Cover (DIMM Card) (1010)
- Battery Pack (1020)
- Keyboard Unit (1040)
- CD-ROM/Diskette Drive Assembly (1060)
- LCD Unit (1080)
- LCD Front Cover (2010)
- LCD Panel (2020)

HPA LCD

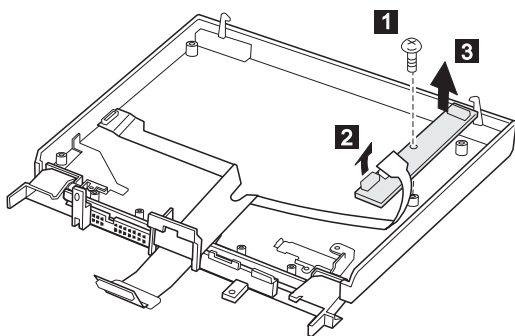

Step	Size (Quantity)	Torque
1	M 2.5 x 6 mm, nylon-coated(1)	3-4 kgcm
Note: Make sure you use the correct screw, and tighten all screws firmly to the torque shown in the table if you have a torque screwdriver. Never use a screw that you removed. Use a new one. Make sure the screws are tightened firmly.		

TFT LCD

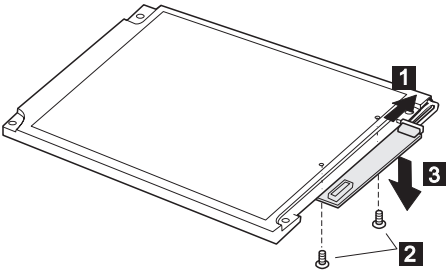

Step	Size (Quantity)	Torque
2	M 2.0 x 3.7 mm, nylon-coated (2)	3-4 kgcm
Note: Make sure you use the correct screw, and tighten all screws firmly to the torque shown in the table if you have a torque screwdriver. Never use a screw that you removed. Use a new one. Make sure the screws are tightened firmly.		

2040 LCD Misc. Parts

- Memory-slot Cover (DIMM Card) (1010)
- Battery Pack (1020)
- Keyboard Unit (1040)
- CD-ROM/Diskette Drive Assembly (1060)
- LCD Unit (1080)
- LCD Front Cover (2010)
- LCD Panel (2020)
- LCD Inverter Card (2030)

Hinges/Latches

HPA LCD

1 2 3 : Hinges
4 5 : Latches

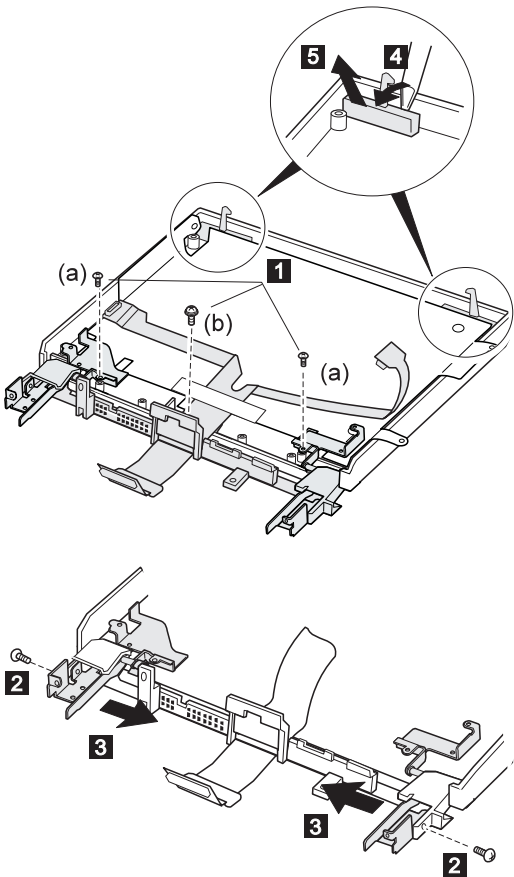

Step	Size (Quantity)	Torque
1	(a) M 2.5 x 6mm, nylon-coated (2)	3-4 kgcm
	(b) M 2.5 x 6mm, special-head (1)	3-3.5 kgcm
2	M 2.5 x 6mm, nylon-coated (2)	3-4 kgcm
<p>Note: Make sure you use the correct screw, and tighten all screws firmly to the torque shown in the table if you have a torque screwdriver. Never use a screw that you removed. Use a new one. Make sure the screws are tightened firmly.</p>		

When replacing: When replacing **the hinge covers** removed in step **5**, attach them to the shield sheet with double-sided adhesive tape as the old ones had been attached.

TFT LCD: This figure shows the TFT type 1 LCD. For the type 2, the same procedure applies.

- 1 2 3** : Hinges
4 5 : Latches

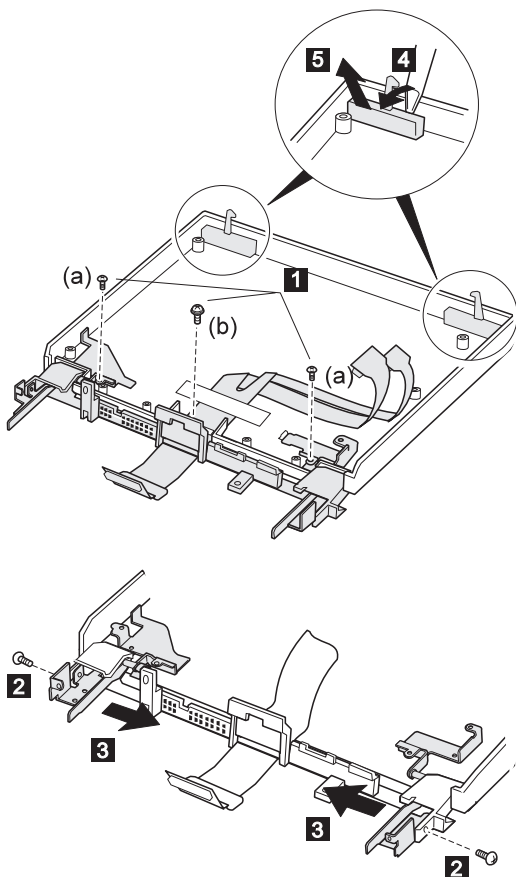

Step	Size (Quantity)	Torque
1	(a) M 2.5 x 6mm, nylon-coated (2)	3-4 kgcm
	(b) M 2.5 x 6mm, special-head (1)	3-3.5 kgcm
2	M 2.5 x 6mm, nylon-coated (2)	3-4 kgcm

Note: Make sure you use the correct screw, and tighten all screws firmly to the torque shown in the table if you have a torque screwdriver. **Never use a screw that you removed. Use a new one. Make sure the screws are tightened firmly.**

When replacing: When replacing the hinge covers removed in step **5**, attach them to the shield sheet with double-sided adhesive tape as the old ones had been attached.

When replacing:

Replace the LCD miscellaneous parts as follows:

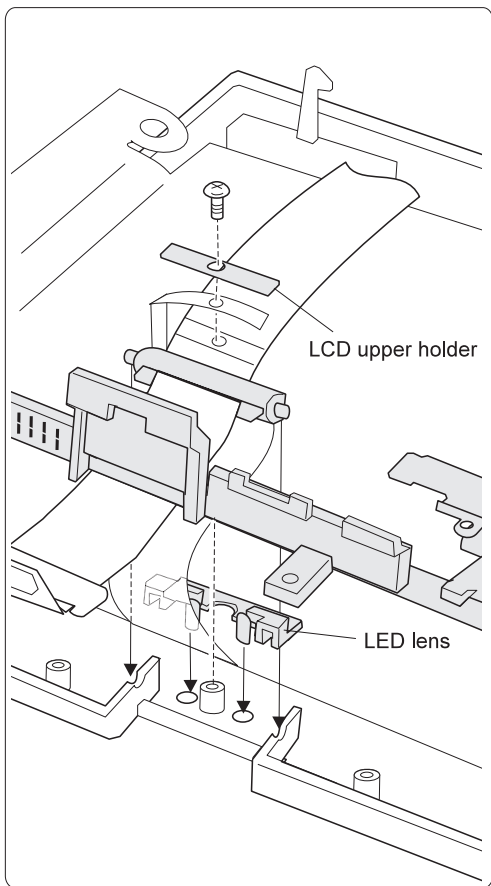

2050 LCD Cable

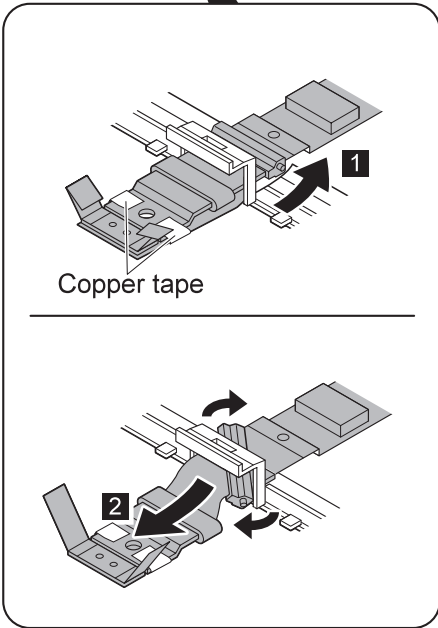
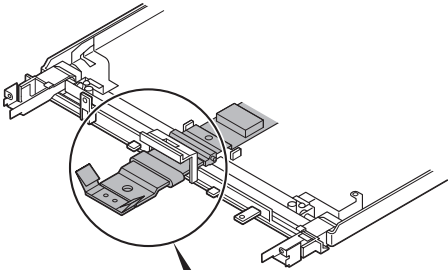

Locations

Front View

- 1** LCD latches
- 2** Color LCD screen
- 3** (TFT display model) Brightness control
(HPA display model) Contrast control
- 4** Fan louver
- 5** Infrared port
- 6** Diskette eject button
- 7** Diskette drive
- 8** CD-ROM emergency eject hole
- 9** CD-ROM eject button
- 10** CD-ROM in-use indicator
- 11** CD-ROM drive
- 12** Stereo speakers
- 13** Palm rest
- 14** TrackPoint III
- 15** Fn key
- 16** Keyboard
- 17** Speaker (Box speaker:subwoofer)
- 18** Indicator panel
- 19** Built-in microphone

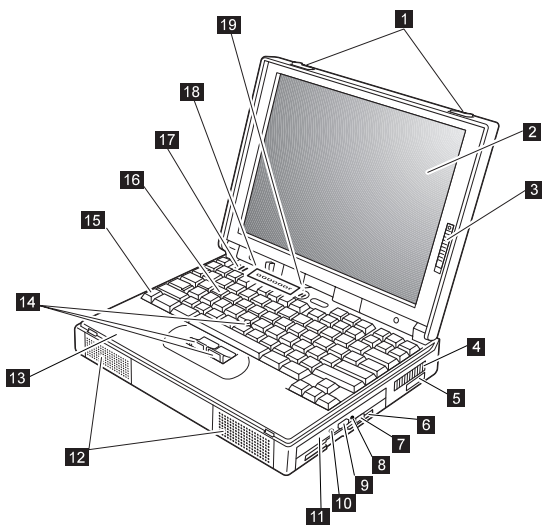

Bottom View

- 1** Memory-slot cover
- 2** Power shutdown switch
- 3** Memory slot
- 4** Expansion connectors
- 5** Battery pack lock
- 6** Battery pack
- 7** Serial number label

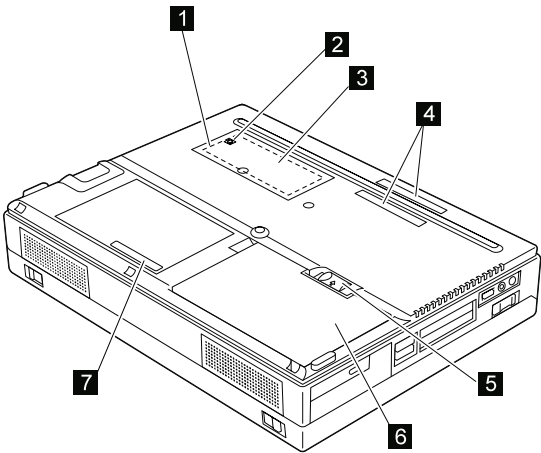

Rear View

- 1** Hard disk drive
- 2** Security keyhole
- 3** PC Card eject buttons
- 4** PC Card slots
- 5** Volume control
- 6** Microphone jack/Line-in jack
- 7** Headphone jack
- 8** Power switch
- 9** External-input device connector
- 10** Power jack
- 11** Universal serial bus (USB) port
- 12** Serial connector
- 13** Parallel connector
- 14** External-monitor connector
- 15** Connector cover
- 16** External suspend mode indicator
- 17** External battery indicator

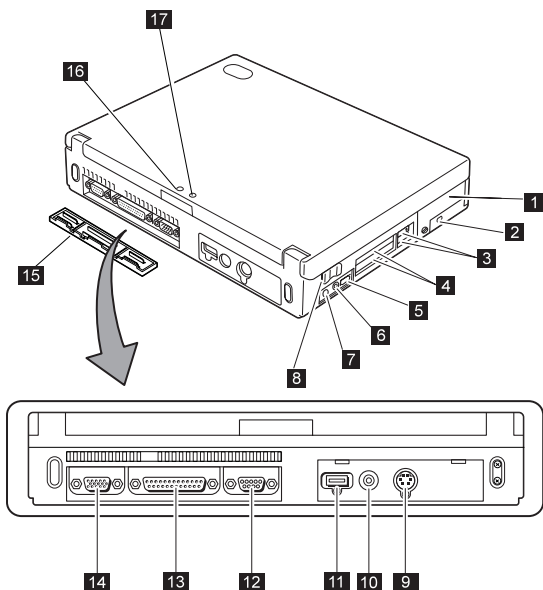

Parts Listing

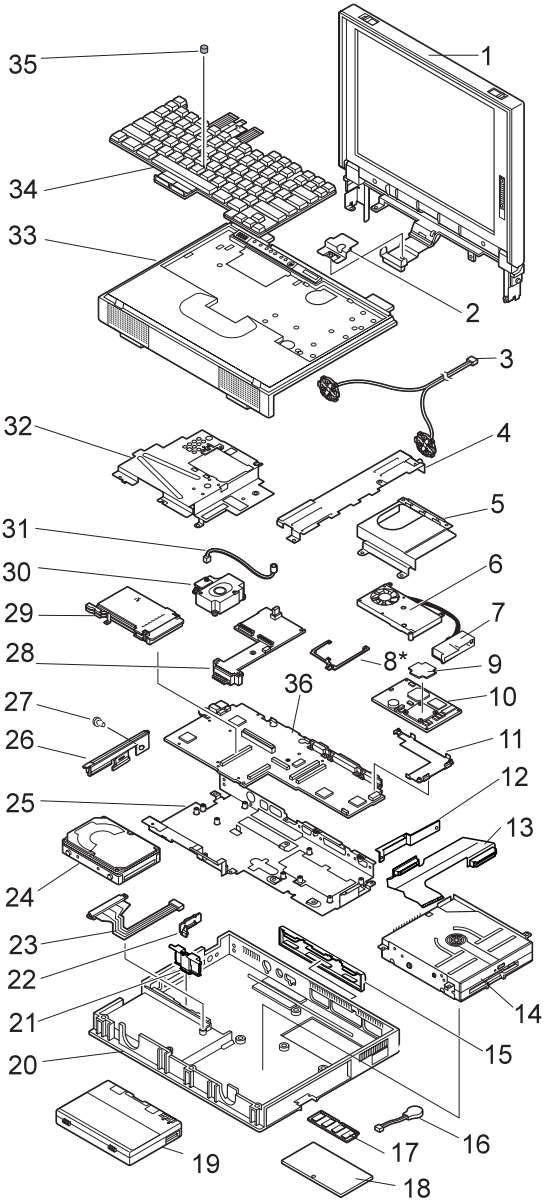

Note: FRU number 8 is available only on the 2635-Dxx/Exx/Fxx.

System Unit

Note on LCD

See page 93 for the LCD identification.

Ref. No.	FRU Name	FRU No.
1	LCD Assembly (12.1 HPA) <i>see page 111 for LCD FRU</i>	
	LCD Assembly (12.1 TFT type 1) <i>see page 113 for LCD FRU</i>	
	LCD Assembly (12.1 TFT type 2) <i>see page 115 for LCD FRU</i>	
2	LCD Cable Holder (included in Ref.No.15 on pages 112, 114 and 116)	
3	Stereo Speaker Assembly	02K4330
4	Support Plate (included in Base Misc. Parts Kit on page 109)	
5	Right Shield Case For 2635-8xx/9xx/Axx/Bxx	05K4749
	For 2635-Dxx/Exx/Fxx	05K5237
6	Fan	05K4746
7	Air Duct (included in Base Misc. Parts Kit on page 109)	
8	MMO Spacer for 2635-Dxx/Exx/Fxx	05K5234
9	Thermal Rubber For 2635-8xx/9xx/Axx/Bxx	05K4748
	For 2635-Dxx/Exx/Fxx	05K5235
10	CPU Card (233 MHz) For 2635-8xx/9xx/Axx/Bxx	12J0408
	For 2635-Dxx/Exx/Fxx	10L0888
	CPU Card (266 MHz) For 2635-8xx/9xx/Axx/Bxx	10L0885
	For 2635-Dxx/Exx/Fxx	10L0887
11	Heat Sink	05K4747
12	Connector Bracket (<i>see page 110</i>)	
13	CD/Diskette Drive Connector Assembly (with-CD model) For 2635-8xx/9xx/Axx/Bxx	05K2637
	For 2635-Dxx/Exx/Fxx	05K2657
13	Diskette Drive Connector Assembly (non-CD model)	83H6527
14	CD-ROM/Diskette Drive Assembly (<i>see page 110</i>)	

Ref. No.	FRU Name	FRU No.
15	Connector Cover	05K4744
16	Backup Battery	02K6498
17	SO-DIMM <i>see "Option Parts List" on page 118</i>	
18	Memory Slot Cover	05K4758
19	Battery Pack For 2635-8xx/9xx/Axx/Bxx For 2635-Dxx/Exx/Fxx	73H9951 02K6509
20	Base Cover Assembly	05K4743
21	Battery Pack Lock Assembly	05K4775
22	Power Switch Knob (included in Base Misc. Parts Kit on page 109)	
23	HDD Cable Assembly	05K2636
24	Hard Disk Drive (<i>see page 110</i>)	
25	Lower Shield Case	05K4745
26	HDD Lid	05K4753
27	HDD Lid Coin Screw	05K4754
28	DC/DC Card For 2635-8xx/9xx/Axx/Bxx For 2635-Dxx/Exx/Fxx	05K3195 10L0930
29	PC Card Slot	05K4862
30	Box Speaker (including Power Switch)	02K4328
31	Microphone Assembly	02K4329
32	Upper Shield Case	05K4750
33	Keyboard Bezel	05K4755
34	Keyboard (<i>see page 117</i>)	
35	TrackPoint III Cap	84G6536
36	System Board For 2635-8xx/9xx/Axx/Bxx For 2635-Dxx/Exx/Fxx Base Misc. Parts Kit including: Air Duct (Ref.No.2) Power Switch Knob(Ref.No.21) Support Plate (Ref.No.4.) Logo for LG Korea Cable Holding Tape	05K3196 10L0929 05K4774 11J8373 11J8376

Hard Disk Drive, CD-ROM, Diskette Drive

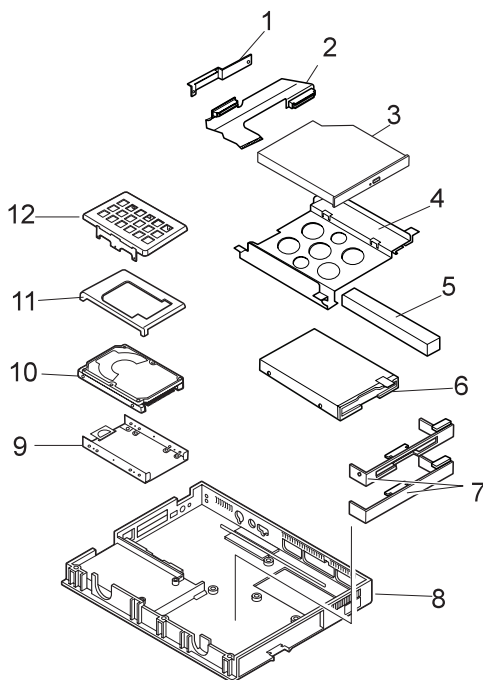

Ref. No.	FRU Name	FRU No.
1	Connector Bracket (included in Ref.No.4. CD/Diskette Drive Bracket)	
2	CD/Diskette Drive Connector Assembly For 2635-8xx/9xx/Axx/Bxx	05K2637
	For 2635-Dxx/Exx/Fxx	05K2657
2	Diskette Drive Connector Assembly (for non-CD model)	83H6527
3	CD-ROM(10 X-24 X)	05K8868
4	CD/Diskette Drive Bracket Kit including: CD/Diskette Drive Bracket (Ref.No.4) Connector Bracket (Ref.No.1) Absorber (Ref.No.5)	05K4751
5	Absorber (included in Ref.No.4 CD/Diskette Drive Bracket)	
6	Diskette Drive	11J8338
7	Diskette Drive Bezel	73H9932
7	Blank Bezel (for non-CD model)	73H9934
8	Base Cover Assembly	05K4743
9	HDD Bracket	05K4752
10	Hard Disk Drive, 2.1 GB (12.5 mm)	22L0004
10	Hard Disk Drive, 3.2 GB (12.5 mm)	83H7086
10	Hard Disk Drive, 4.0 GB (12.5 mm)	83H7085
10	Hard Disk Drive, 5.1 GB (17 mm) (See page 65 for relation between the HDD and the spacers.)	83H7084
11	HDD Spacer	05K4776

LCD FRU

HPA (Labeled 05K9309 or 05K9320)

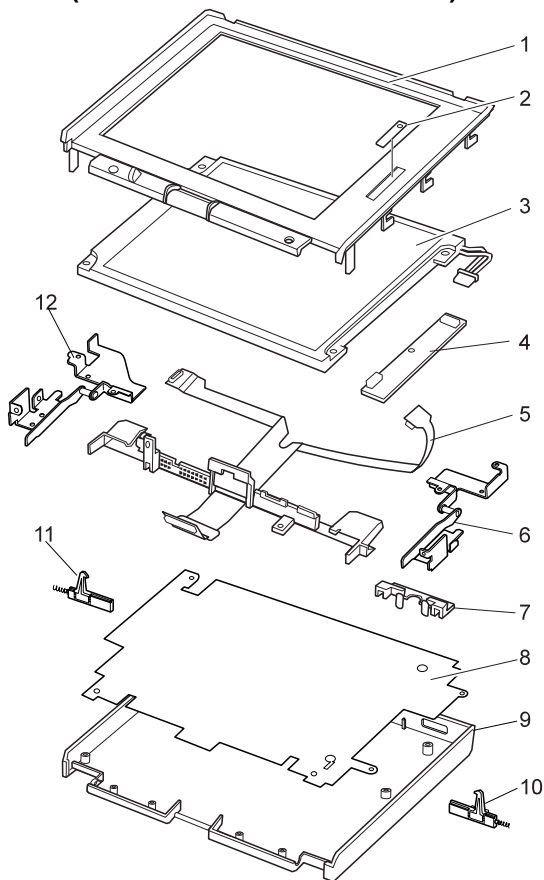

Ref. No.	FRU Name	FRU No.
1	Front Bezel (included in Ref.No.13 LCD Cover Kit)	
2	Contrast Control Knob (included in Ref.No.15 LCD Misc. Parts Kit)	
3	LCD Panel	05K9336
4	Inverter Card	05K3194
5	LCD Cable Assembly	12J0139
6	Right Hinge (included in Ref.No.14 Hinge Kit)	
7	LED Lens (included in Ref.No.15 LCD Misc.Kit)	
8	Insulation Sheet (included in Ref.No.13 LCD Cover Kit)	
9	LCD Cover (included in Ref.No.13 LCD Cover Kit)	
10	Right Latch (included in Ref.No.15 LCD Misc. Parts Kit)	
11	Left Latch (included in Ref.No.15 LCD Misc. Parts Kit)	
12	Left Hinge (included in Ref.No.14 Hinge Kit)	
13	LCD Cover Kit including: Front Bezel (Ref.No.1) Insulation Sheet (Ref.No.8) LCD Cover (Ref.No.9) Logo (Front, Rear) Hinge Cap Screw Cap	05K4779
14	Hinge Kit including: Right Hinge (Ref.No.6) Left Hinge (Ref.No.14) Screw Cap	73H9942
15	LCD Misc. Parts Kit including: LCD Cable Holder (Ref.No.2 on page 108) Contrast Control Knob (Ref.No.2) LED Lens (Ref.No.7) Right Latch, Spring, Holder (Ref.No.10) Left Latch, Spring, Holder (Ref.No.11) Screw Cap	73H9949

TFT 1 (Labeled 05K9312 or 05K9322)

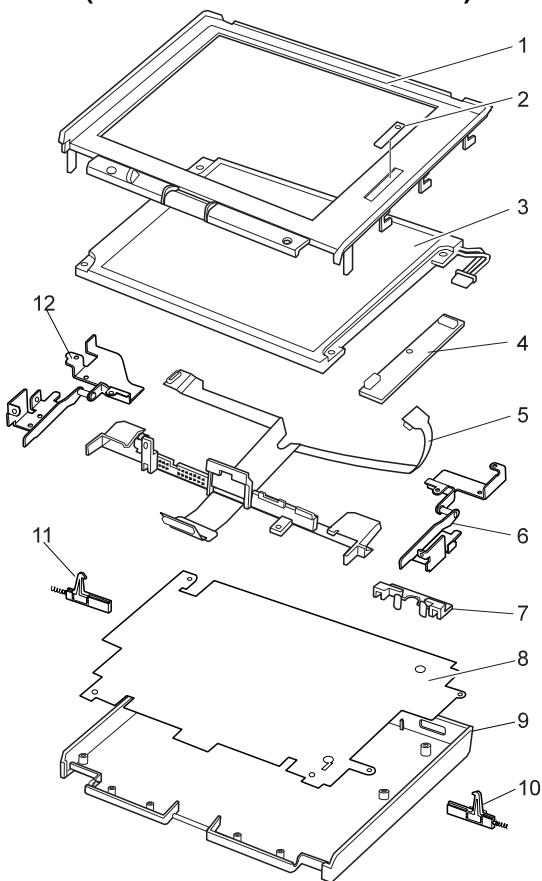

Ref. No.	FRU Name	FRU No.
1	Front Bezel (included in Ref.No.13 LCD Cover Kit)	
2	Brightness Control Knob (included in Ref.No.15 LCD Misc. Parts Kit)	
3	LCD Panel	05K9335
4	Inverter Card	05K3197
5	LCD Cable Assembly	73H9948
6	Right Hinge (included in Ref.No.14 Hinge Kit)	
7	LED Lens (included in Ref.No.15 LCD Misc. Kit)	
8	Insulation Sheet (included in Ref.No.13 LCD Cover Kit)	
9	LCD Cover (included in Ref.No.13 LCD Cover Kit)	
10	Right Latch (included in Ref.No.15 LCD Misc. Parts Kit)	
11	Left Latch (included in Ref.No.15 LCD Misc. Parts Kit)	
12	Left Hinge (included in Ref.No.14 Hinge Kit)	
13	LCD Cover Kit including: Front Bezel (Ref.No.1) Insulation Sheet (Ref.No.8) LCD Cover (Ref.No.9) Logo (Front, Rear) Hinge Cap Screw Cap	05K4780
14	Hinge Kit including: Right Hinge (Ref.No.6) Left Hinge (Ref.No.14) Screw Cap	73H9943
15	LCD Misc. Parts Kit including: LCD Cable Holder (Ref.No.2 on page 108) Contrast Control Knob (Ref.No.2) LED Lens (Ref.No.7) Right Latch, Spring, Holder (Ref.No.10) Left Latch, Spring, Holder (Ref.No.11) Screw Cap	73H9949

TFT 2 (Labeled 05K9311 or 05K9321)

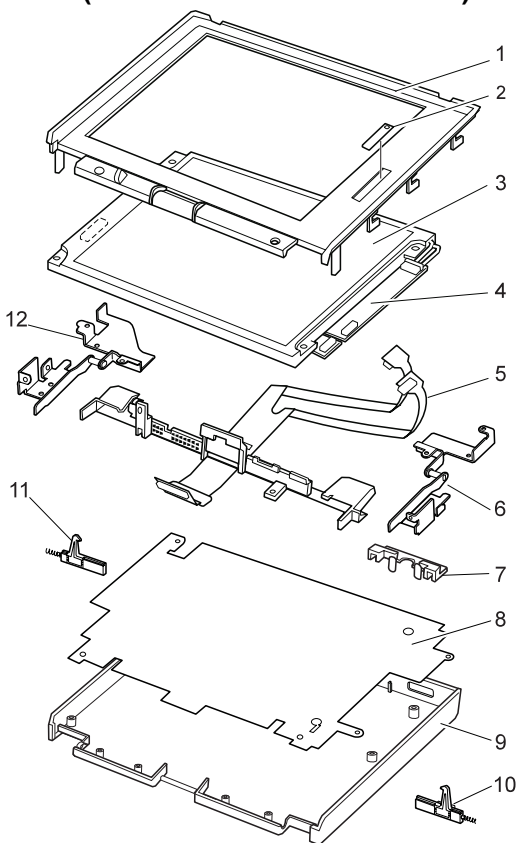

Ref. No.	FRU Name	FRU No.
1	Front Bezel (included in Ref.No.13 LCD Cover Kit)	
2	Brightness Control Knob (included in Ref.No.15 LCD Misc. Parts Kit)	
3	LCD Panel	05K9315
4	Inverter Card	05K3150
5	LCD Cable Assembly	05K4358
6	Right Hinge (included in Ref.No.14 Hinge Kit)	
7	LED Lens (included in Ref.No.15 LCD Misc. Kit)	
8	Insulation Sheet (included in Ref.No.13 LCD Cover Kit)	
9	LCD Cover (included in Ref.No.13 LCD Cover Kit)	
10	Right Latch (included in Ref.No.15 LCD Misc. Parts Kit)	
11	Left Latch (included in Ref.No.15 LCD Misc. Parts Kit)	
12	Left Hinge (included in Ref.No.14 Hinge Kit)	
13	LCD Cover Kit including: Front Bezel (Ref.No.1) Insulation Sheet (Ref.No.8) LCD Cover (Ref.No.9) Logo (Front, Rear) Hinge Cap Screw Cap	05K4781
14	Hinge Kit including: Right Hinge (Ref.No.6) Left Hinge (Ref.No.14) Screw Cap	73H9943
15	LCD Misc. Parts Kit including: LCD Cable Holder (Ref.No.2 on page 108) Contrast Control Knob (Ref.No.2) LED Lens (Ref.No.7) Right Latch, Spring, Holder (Ref.No.10) Left Latch, Spring, Holder (Ref.No.11) Screw Cap	73H9949

Keyboard

Arabic	02K4351
Belgian	02K4341
Canadian French	02K4344
Czech	02K4352
Danish	02K4343
Dutch	02K4337
French	02K4335
German	02K4334
Greek	02K4353
Hebrew	02K4354
Hungarian	02K4355
Italian	02K4336
Japanese	02K4333
Korean	02K4345
Latin American Spanish	02K4348
Norwegian	02K4342
Poland	02K4357
Portuguese	02K4356
Russian	02K4346
Slovakian	02K4358
Slovenian	02K4359
Spanish	02K4339
Swedish or Finnish	02K4338
Swiss	02K4340
Taiwanese	02K4347
Thai	02K4349
Turkish	02K4350
U.K. English	02K4332
U.S. English	02K4331

Option Parts List

Miscellaneous Parts

<i>FRU Name</i>	<i>FRU Number</i>
Screw Kit	05K4837
including:	
Hex stud, D-Sub (6)	
M2 x 1.7, Special (4)	
M2 x 2.4, Special (2)	
M2 x 6, Bind, nylon-coated (4)	
M2 x 18, Bind, nylon-coated (3)	
M2.5 x 6, Special (2)	
M2.5 x 6, Big (1)	
M2.5 x 6, Bind, Black, nylon-coated (30)	
M2.5 x 8, Bind, Black, nylon-coated (7)	
M2.5 x 12, Bind, nylon-coated (3)	
M2.5 x 22, Bind, nylon-coated (2)	
M2.5 x 25, Bind, nylon-coated (1)	
M2.6 x 2.8, Bind (3)	
M2.6 x 4, Bind (2)	
M3 x 3, Flathead, nylon-coated (4)	
Screw tapping (2)	

Options

Notes

1. If you need to replace the AC Adapter, use the one for the country you are in even if the computer is from a different country.
2. The warranty for the system unit does not apply to all options.

FRU Name	FRU Number
Headset	85G1529
4.0 GB Hard Disk Drive Assembly	83H7085
AC Adapter (56 W, 3-prong) ¹	11J8956
AC Adapter (56 W, 3-prong) ¹	02K6496
AC Adapter (for Japan, 2-prong) ²	11J8974
AC Adapter (for Japan, 2-prong) ²	02K6497
Microphone	66G7871
PS/2 Miniature Mouse	95F5723
ThinkPad 380/385 Port Replicator	84G1320
ThinkPad 560 Port Replicator	12J1602
ThinkPad Enhanced Port Replicator	11J9000
Upper Cover Set	84G1321
SO-DIMM 8 MB 70ns	42H2767
SO-DIMM 16 MB 70ns	42H2768
SO-DIMM 16 MB 60ns	01K1115
SO-DIMM 32 MB 60ns	42H2769
SO-DIMM 64 MB 60ns	42H2817
Interface Cable to System for Keyboard	84G2531
Interface Cable to Keyboard for Keypad	84G2532
Mini-DIN to Mini-DIN Cable	84G6474

-
- 1 The 3-prong adapters are interchangeable; you can order either one.
 - 2 The 2-prong adapters are interchangeable; you can order either one.

Numeric Keypad

Belgian	95F5741
Canadian French	95F5466
Danish	95F5467
Dutch	95F5467
French	95F6313
German	95F6314
Greek	95F5467
Hebrew	95F5741
Icelandic	95F5467
Italian	95F6316
Japanese	79F6401
Norwegian	95F5467
Spanish	95F6315
Swedish or Finnish	95F5468
Swiss French	95F5711
Swiss German	95F5715
Turkish	95F5467
U.K. English	95F5741
U.S. English	95F5741

Black Keypad

French	84G6286
German	84G6280
Italian	84G6292
Norwegian	84G6310
Swedish	84G6304
U.K. English	84G6298
U.S. English	84G2530

Black Keyboard

French	84G6285
German	84G6279
Italian	84G6291
Norwegian	84G6309
Swedish	84G6303
U.K. English	84G6297
U.S. English	84G2529

Accessories

Keyboard/Mouse Cable	54G0444
----------------------	---------

Tools

Tri-Connector Wrap Plug	72X8546
PC Test Card	35G4703
Audio Wrap Cable	66G5180
USB Parallel Test Cable	05K2580
Screwdriver Kit	95F3598
Torque Screwdriver	05K4695
5-mm Socket Wrench	05K4694
Screwdriver	05K4693
ThinkPad Hardware Maintenance Diskette Version 1.40 (See "Maintenance Diskette Download" on page 57.)	

Power Cords

IBM power cords for a specific country are usually available only in that country:

For 2-pin power cords:

IBM Power Cord Part Number	Used in These Countries
13H5264	Bahamas, Barbados, Bermuda, Bolivia, Canada, Cayman Islands, Colombia, Costa Rica, Dominican Republic, Ecuador, El Salvador, Guatemala, Guyana, Haiti, Honduras, Jamaica, Korea (South), Mexico, Netherlands Antilles, Nicaragua, Panama, Peru, Philippines, Saudi Arabia, Suriname, Taiwan, Thailand, Trinidad (West Indies), United States of America, Venezuela
13H5267	Abu Dhabi, Albania, Antigua, Bahrain, Brunei, Dubai, Fiji, India, Ireland, Kenya, Kuwait, Macao, Malaysia, Nigeria, Oman, People's Republic of China (including Hong Kong), Qatar, Singapore, United Kingdom
13H5270	Austria, Belgium, Bulgaria, Chile, Czech Republic, Denmark, Egypt, Finland, France, Germany, Greece, Hungary, Iceland, Indonesia, Israel, Italy, Netherlands, Norway, Poland, Portugal, Romania, Slovakia, Spain, Sweden, Switzerland, Turkey, former Yugoslavia
13H5273	Japan
13H5276	Argentina, Australia, New Guinea, New Zealand, Papua New Guinea, Paraguay, Uruguay
13H5279	Bangladesh, Pakistan, South Africa, Sri Lanka

For 3-pin slim power cords:

IBM Power Cord P/N	Used in These Countries
76H3514	Argentina, Australia, New Zealand, Papua New Guinea, Paraguay, Uruguay
76H3516	Bahamas, Barbados, Bermuda, Bolivia, Canada, Cayman Islands, Colombia, Costa Rica, Dominican Republic, Ecuador, El Salvador, Guatemala, Guyana, Haiti, Honduras, Jamaica, Mexico, Netherlands Antilles, Nicaragua, Panama, Peru, Philippines, Saudi Arabia, Suriname, Taiwan, Trinidad (West Indies), United States of America, Venezuela, Thailand
76H3518	Austria, Belgium, Bulgaria, Czech Republic, Egypt, Finland, France, Germany, Greece, Hungary, Iceland, Indonesia, Netherlands, Norway, Poland, Portugal, Romania, Slovakia, Spain, Sweden, Turkey, former Yugoslavia
76H3520	Denmark
76H3522	Bangladesh, Pakistan, South Africa, Sri Lanka
76H3524	Abu Dhabi, Albania, Antigua, Bahrain, Brunei, Dubai, Fiji, India, Ireland, Kenya, Kuwait, Macao, Malaysia, Nigeria, Oman, People's Republic of China (including Hong Kong), Qatar, Singapore, United Kingdom
76H3526	Japan
76H3528	Liechtenstein, Switzerland
76H3530	Chile, Ethiopia, Italy, Libya
76H3532	Israel
76H3535	Korea

Notices

References in this publication to IBM products, programs, or services do not imply that IBM intends to make these available in all countries in which IBM operates. Any reference to an IBM product, program, or service is not intended to state or imply that only that IBM product, program, or service may be used. Any functionally equivalent product, program, or service that does not infringe any of the intellectual property rights of IBM may be used instead of the IBM product, program, or service. The evaluation and verification of operation in conjunction with other products, except those expressly designated by IBM, are the responsibility of the user.

IBM may have patents or pending patent applications covering subject matter in this document. The furnishing of this document does not give you any license to these patents. You can send license inquiries, in writing, to the IBM Director of Licensing, IBM Corporation, 500 Columbus Avenue, Thornwood, NY 10594, U.S.A.

Trademarks

The following terms are trademarks of the IBM Corporation in the United States or other countries or both:

- IBM
- ThinkPad
- TrackPoint
- TrackPoint III

Microsoft, Windows, and the Windows 95 flag logo are trademarks or registered trademarks of Microsoft Corporation.

Pentium®, MMX™, ProShare®, LANDesk®, and ActionMedia® are trademarks or registered trademarks of Intel Corporation in the U.S. and other countries.

Other company, product, and service names used in this publication may be trademarks or service marks of others.



Part Number: 10L9623

Printed in U.S.A.

S10L-9623-00

