

Notice

© 2000 Compaq Computer Corporation.

COMPAQ, the Compaq logo, and ARMADA Registered in U. S. Patent and Trademark Office

Microsoft, Windows, Windows NT, are registered trademarks of Microsoft Corporation in the United States and/or other countries. Intel and Pentium are registered trademarks of Intel Corporation in the United States and other countries.

All other product names mentioned herein may be trademarks or registered trademarks of their respective companies.

Compaq shall not be liable for technical or editorial errors or omissions contained herein. The information in this document is subject to change without notice and is provided “as is” without warranty of any kind. The entire risk arising out of the use of this information remains with the recipient. In no event shall Compaq be liable for any direct, consequential, incidental, special, punitive, or other damages whatsoever (including without limitation, damages for loss of business profits, business interruption, or loss of business information), even if Compaq has been advised of the possibility of such damages. The limited warranties for Compaq products are exclusively set forth in the documentation accompanying such products. Nothing herein should be construed as constituting a further or additional warranty.

MAINTENANCE AND SERVICE GUIDE

Compaq Armada E500 and Armada V300 Series of Personal Computers

Fourth Edition April 2000

First Edition November 1999

Published in the U.S.A., U.K., Singapore, and Taiwan.

Documentation Part Number 128679-004

Spare Part Number 162812-001

CONTENTS

preface

USING THIS GUIDE

chapter 1

PRODUCT DESCRIPTION

1.1 Computer Features and Models	1-1
Models	1-2
Features	1-8
1.2 Intelligent Manageability	1-10
Accessing the Web Agent	1-10
Asset Management	1-10
Fault Management	1-11
Fault Management Alerts	1-12
Security Management	1-12
Configuration Management	1-13
Managing Power	1-13
Accessing Power Management	1-13
Power Management Levels	1-13
1.3 Computer External Components	1-14
1.4 Design Overview	1-26

chapter 2

TROUBLESHOOTING

2.1 Preliminary Steps	2-2
2.2 Clearing Passwords	2-2
2.3 Power-On Self-Test (POST)	2-4
2.4 POST Error Messages	2-4

2.5	Compaq Utilities	2-9
	Selecting Computer Setup or Compaq Diagnostic for Windows.....	2-9
	Using Computer Setup.....	2-10
	File Menu	2-11
	Security Menu	2-12
	Advanced Menu	2-13
	Using Compaq Diagnostics for Windows	2-14
	Factory Default Settings	2-15
2.6	Troubleshooting Without Diagnostics.....	2-17
	Before Replacing Parts.....	2-17
	Obtaining Update Information with Info Messenger	2-17
	Checklist for Solving Problems	2-18

chapter 3

ILLUSTRATED PARTS CATALOG

3.1	Serial Number Location.....	3-1
3.2	Computer System Major Components	3-2
3.3	Miscellaneous Plastics Kit Components	3-10
3.4	Mass Storage Devices.....	3-11
3.5	Miscellaneous	3-12

chapter 4

REMOVAL AND REPLACEMENT PRELIMINARIES

4.1	Tools Required.....	4-1
4.2	Service Considerations	4-2
	Plastic Parts	4-1
	Cables and Connectors.....	4-2
4.3	Preventing Damage to Removable Drives	4-3
4.4	Preventing Electrostatic Damage.....	4-3
4.5	Packaging and Transporting Precautions	4-4
4.6	Workstation Precautions.....	4-4
4.7	Grounding Equipment and Methods	4-5

REMOVAL AND REPLACEMENT PROCEDURES

- 5.1 Serial Number5-1
- 5.2 Disassembly Reference Chart5-2
- 5.3 Preparing the Computer for Disassembly5-3
- 5.4 Computer Feet5-4
- 5.5 Mini PCI Slot5-5
 - Removing the Mini PCI Slot Cover5-5
 - Installing a Modem or Network Interface Card5-6
- 5.6 Touch Button5-7
 - Removing the Touch Button5-7
- 5.7 Keyboard5-9
 - Removing the Keyboard.....5-10
- 5.8 Memory5-13
 - Removing a Memory Expansion Board.....5-14
 - Installing a Memory Expansion Board5-15
- 5.9 Display.....5-16
 - Removing the Display5-17
- 5.10 Real Time Clock (RTC) Battery5-21
 - Removing the RTC Battery5-21
- 5.11 LED Board5-22
 - Removing the LED Board.....5-22
- 5.12 Top Cover.....5-23
 - Removing the Top Cover5-23
- 5.13 Front Shield.....5-27
 - Removing the Front Shield5-27
- 5.14 Diskette Drive (Armada V300 only).....5-29
 - Removing the Diskette Drive5-29
- 5.15 System Board5-30
 - Removing the System Board.....5-30
- 5.16 Voltage Converter Board5-34
 - Removing the Voltage Converter Board.....5-34
- 5.17 Fan5-36
 - Removing the Fan.....5-36

chapter 6

SPECIFICATIONS..... 6-1

appendix a

CONNECTOR PIN ASSIGNMENTSA-1

appendix b

POWER CORD SET REQUIREMENTS.....B-1

preface

USING THIS GUIDE

This *Maintenance and Service Guide* is a troubleshooting reference that can be used when servicing the Compaq Armada E500 and Armada V300 Series of Personal Computers.

Compaq Computer Corporation reserves the right to make changes to the Compaq Armada E500 and Armada V300 Series of Personal Computers without notice.

Symbols

The following words and symbols mark special messages throughout this guide:



WARNING: Text set off in this manner indicates that failure to follow directions in the warning could result in bodily harm or loss of life.



CAUTION: Text set off in this manner indicates that failure to follow directions in the caution could result in damage to equipment or loss of information.

IMPORTANT: Text set off in this manner presents clarifying information or specific instructions.

NOTE: Text set off in this manner presents commentary, sidelights, or interesting points of information.

Technician Notes



WARNING: Only authorized technicians trained by Compaq should repair this equipment. All troubleshooting and repair procedures are detailed to allow only subassembly/module level repair. Because of the complexity of the individual boards and subassemblies, no one should attempt to make repairs at the component level or to make modifications to any printed wiring board. Improper repairs can create a safety hazard. Any indication of component replacement or printed wiring board modifications may void any warranty or exchange allowances.



WARNING: The computer is designed to be electrically grounded. To ensure proper operation, plug the AC power cord into a properly grounded electrical outlet only.



CAUTION: To properly ventilate the system, you must provide at least 3 inches (7.62 cm) of clearance on the left and right sides of the computer.

Serial Number

When requesting information or ordering spare parts, provide the computer serial number. The serial number is on the bottom of the computer.

Locating Additional Information

The following documentation provides information for the computer:

- Compaq Armada E500 and Armada V300 Series of Personal Computers documentation set
- Compaq Armada E500 and Armada V300 Series of Personal Computers *Technical Reference Guide*
- Microsoft Operating System Manual
- Compaq Service Training Guides
- Compaq Service Advisories and Bulletins
- *Compaq QuickFind*
- *Compaq Service Quick Reference Guide*
- Compaq Internet site at <http://www.Compaq.com>

chapter 1

PRODUCT DESCRIPTION

1.1 Computer Features and Models

The Compaq Armada E500 and Armada V300 Series of Personal Computers offer advanced modularity, Intel Pentium II, III, and Intel Celeron processors with 64-bit architecture, industry-leading Accelerated Graphics Port (AGP) implementation, and extensive multimedia support. The computers provide desktop functionality and connectivity through the optional expansion base, convenience base, or port replicator.



Figure 1-1. Compaq Armada E500 and Armada V300 Personal Computers

Models

The Armada E500 model naming conventions are shown in Table 1-1. The computer model designation is composed of a group of characters that define each model's features.

**Table 1-1
Compaq Armada E500
Model Naming Convention**

Key																					
A	E	5		P3	700	T5X	18	V	M	64	58	N	S	F							
1	2	3	4	5-6	7-9	10-12	13-14	15	16	17-19	20-21	22	23	24							
KEY	DESCRIPTION			OPTIONS																	
1	Brand designator			A = Armada																	
2	Segment designator			E = Expansion																	
3	Series			5 = 500																	
4	Blank																				
5-6	Processor type			P3 = Intel Pentium III					P2 = Intel Pentium II												
7-9	Processor speed			700 = 700 MHz			500 = 500 MHz			400 = 400 MHz			650 = 650 MHz			450 = 450 MHz			366 = 366 MHz		
10	Panel type			T = TFT																	
11	Panel size			5 = 15.x"				3 = 13.x"				4 = 14.x"				2 = 12.x"					
12	Panel resolution			X = XGA					S = SVGA												
13-14	Hard drive size (in GB, 1-2 digits)			18 = 18.0 GB				6 = 6.0 GB				12 = 12.0 GB				4 = 4.3 GB					
15	Optical drive			D = 24X Max CD-ROM drive					V = DVD-ROM drive												
16	Integrated communication			M = Mini PCI V.90 modem				C = NIC/modem combo			0 = none										
17-19	RAM (in MB, 2-3 digits)			64 = 64 MB																	
20-21	Operating system			98 = Windows 98					N4 = Windows NT 4.0				58 = Windows 95/98 dual install*					N2 = Windows NT 4.0/Windows 2000 dual install			
22	NAFTA			N = NAFTA																	
23	Pointing device			S = Pointing stick				P = TouchPad													
24	Security																				

* End user must make a one-time selection between Windows 95 and Windows 98. If end user desires rejected product(s) after selection is made, end user must acquire and pay for rejected product(s) separately.

**Table 1-2
Compaq Armada E500
Computer Models**

1	2	3	4	5-6	7-9	10	11	12	13-14	15	16	17-19	20-21	22	23	24	SKU#	Config. Code
A	E	5		P3	700	T	5	X	18	V	M	128	58				174518-XX1	DX44
A	E	5		P3	700	T	5	X	18	V	M	128	58	N			174518-XX3	DX45
A	E	5		P3	700	T	5	X	18	V	M	128	N4				174518-XX6	DX46
A	E	5		P3	700	T	5	X	18	V	M	128	N4	N			174518-XX7	DX47
A	E	5		P3	700	T	5	X	18	V	M	128	N2				174518-XX8	FFH2
A	E	5		P3	700	T	5	X	18	V	M	128	N2				174518-XX9	FFH3
A	E	5		P3	700	T	5	X	18	V	O	128	58				174517-XX1	DX41
A	E	5		P3	700	T	5	X	18	V	O	128	N4				174517-XX6	DX43
A	E	5		P3	700	T	5	X	18	V	O	128	N2				174517-XX8	FFH1
A	E	5		P3	700	T	5	X	18	V	C	128	58				174519-XX1	DX48
A	E	5		P3	700	T	5	X	18	V	C	128	N4				174519-XX6	DX49
A	E	5		P3	700	T	5	X	18	V	C	128	N2				174519-XX8	FFH4
A	E	5		P3	650	T	4	X	12	V	O	64	58				161608-XX1	DPB1
A	E	5		P3	650	T	4	X	12	V	O	64	N4				161608-XX6	DPB3
A	E	5		P3	650	T	4	X	12	V	O	64	N2				161608-XX8	FFD5
A	E	5		P3	650	T	4	X	12	V	M	64	58				161609-XX1	DPB4
A	E	5		P3	650	T	4	X	12	V	M	64	58	N			161609-XX3	DPB5
A	E	5		P3	650	T	4	X	12	V	M	64	N4				161609-XX6	DPB6
A	E	5		P3	650	T	4	X	12	V	M	64	N4	N			161609-XX7	DPB7
A	E	5		P3	650	T	4	X	12	V	M	64	N2				161609-XX8	FFD6
A	E	5		P3	650	T	4	X	12	V	M	64	N2	N			161609-XX9	FFD7
A	E	5		P3	650	T	4	X	12	V	C	64	58				164764-XX1	DPB8
A	E	5		P3	650	T	4	X	12	V	C	64	N4				164764-XX6	DPB9
A	E	5		P3	650	T	4	X	12	V	C	64	N2				164764-XX8	FFD8
A	E	5		P3	600	T	4	X	12	D	O	64	58				161606-XX1	DN91
A	E	5		P3	600	T	4	X	12	D	O	64	N4				161606-XX6	DN93
A	E	5		P3	600	T	4	X	12	D	O	64	N2				161606-XX8	FFD1
A	E	5		P3	600	T	4	X	12	D	M	64	58				161607-XX1	DN94
A	E	5		P3	600	T	4	X	12	D	M	64	58	N			161607-XX3	DN95
A	E	5		P3	600	T	4	X	12	D	M	64	N4				161607-XX6	DN96
A	E	5		P3	600	T	4	X	12	D	M	64	58	N			161607-XX7	DN97
A	E	5		P3	600	T	4	X	12	D	M	64	N2				161607-XX8	FFD2
A	E	5		P3	600	T	4	X	12	D	M	64	N2	N			161607-XX9	FFD3
A	E	5		P3	600	T	4	X	12	D	C	64	58				164763-XX1	DN98
A	E	5		P3	600	T	4	X	12	D	C	64	N4				164763-XX6	DN99
A	E	5		P3	600	T	4	X	12	D	C	64	N2				164763-XX8	FFD4
A	E	5		P3	500	T	3	X	6	D	O	64	58				161604-XX1	DNN1
A	E	5		P3	500	T	3	X	6	D	O	64	98				161604-XX4	DNN2
A	E	5		P3	500	T	3	X	6	D	O	64	N4				161604-XX6	DNN3
A	E	5		P3	500	T	3	X	6	D	M	64	58				161605-XX1	DNN4
A	E	5		P3	500	T	3	X	6	D	M	64	58	N			161605-XX3	DNN5
A	E	5		P3	500	T	3	X	6	D	M	64	N4				161605-XX6	DNN6
A	E	5		P3	500	T	3	X	6	D	M	64	N4	N			161605-XX7	DNN7
A	E	5		P3	500	T	3	X	6	D	C	64	58				164749-XX1	DNN8
A	E	5		P3	500	T	3	X	6	D	C	64	N4				164749-XX6	DN83

Continued

Table 1-2 *continued*

1	2	3	4	5-6	7-9	10	11	12	13-14	15	16	17-19	20-21	22	23	24	SKU#	Config. Code
A	E	5		P3	500	T	2	S	6	D	0	64	58				161602-XX1	DNM1
A	E	5		P3	500	T	2	S	6	D	0	64	98				161602-XX4	DNM2
A	E	5		P3	500	T	2	S	6	D	0	64	N4				161602-XX6	DNM3
A	E	5		P3	500	T	2	S	6	D	M	64	58				161603-XX1	DNM4
A	E	5		P3	500	T	2	S	6	D	M	64	58	N			161603-XX3	DNM5
A	E	5		P3	500	T	2	S	6	D	M	64	N4				161603-XX6	DNM6
A	E	5		P3	500	T	2	S	6	D	M	64	N4	N			161603-XX7	DNM7
A	E	5		P3	500	T	2	S	6	D	C	64	58				166761-XX1	DVM1
A	E	5		P3	500	T	2	S	6	D	C	64	N4				166761-XX6	DVM2
A	E	5		P3	450	T	4	X	12	D	0	64	58				127669-XX1	CZQ1
A	E	5		P3	450	T	4	X	12	D	0	64	98				127669-XX4	CZQ2
A	E	5		P3	450	T	4	X	12	D	0	64	N4				127669-XX6	CZQ3
A	E	5		P3	450	T	4	X	12	D	M	64	58				127670-XX1	CZQ4
A	E	5		P3	450	T	4	X	12	D	M	64	58	N			127670-XX3	CZQ5
A	E	5		P3	450	T	4	X	12	D	M	64	N4				127670-XX6	CZQ6
A	E	5		P3	450	T	4	X	12	D	M	64	N4	N			127670-XX7	CZQ7
A	E	5		P3	450	T	4	X	12	D	C	64	58				164751-XX1	DN84
A	E	5		P3	450	T	4	X	12	D	C	64	N4				164751-XX6	DN85
A	E	5		P3	450	T	3	X	6	D	0	64	58				161604-XX1	DNN1
A	E	5		P3	450	T	3	X	6	D	0	64	98				161604-XX4	DNN2
A	E	5		P3	450	T	3	X	6	D	0	64	N4				161604-XX6	DNN3
A	E	5		P3	450	T	3	X	6	D	M	64	58				161605-XX1	DNN4
A	E	5		P3	450	T	3	X	6	D	M	64	58	N			161605-XX3	DNN5
A	E	5		P3	450	T	3	X	6	D	M	64	N4				161605-XX6	DNN6
A	E	5		P3	450	T	3	X	6	D	M	64	N4	N			161605-XX7	DNN7
A	E	5		P3	450	T	3	X	6	D	C	64	58				164749-XX1	DNN8
A	E	5		P3	450	T	3	X	6	D	C	64	N4				164749-XX6	DN83
A	E	5		P2	400	T	4	X	6	D	0	64	58				152675-XX1	DC41
A	E	5		P2	400	T	4	X	6	D	0	64	98				152675-XX4	DC42
A	E	5		P2	400	T	4	X	6	D	0	64	N4				152675-XX6	DC43
A	E	5		P2	400	T	4	X	6	D	M	64	58				152676-XX1	DC44
A	E	5		P2	400	T	4	X	6	D	M	64	58	N			152676-XX3	DC45
A	E	5		P2	400	T	4	X	6	D	M	64	N4				152676-XX6	DC46
A	E	5		P2	400	T	4	X	6	D	M	64	N4	N			152676-XX7	DC47
A	E	5		P2	400	T	4	X	6	D	C	64	58				164748-XX1	DN81
A	E	5		P2	400	T	4	X	6	D	C	64	N4				164748-XX6	DN82
A	E	5		P2	366	T	2	S	4	D	0	64	58				155058-XX1	DJC1
A	E	5		P2	366	T	2	S	4	D	0	64	98				155058-XX4	DJC2
A	E	5		P2	366	T	2	S	4	D	0	64	N4				155058-XX6	DJC3
A	E	5		P2	366	T	2	S	4	D	M	64	58				155059-XX1	DJC4
A	E	5		P2	366	T	2	S	4	D	M	64	58	N			155059-XX3	DJC5
A	E	5		P2	366	T	2	S	4	D	M	64	N4				155059-XX6	DJC6
A	E	5		P2	366	T	2	S	4	D	M	64	N4	N			155059-XX7	DJC7

The Armada V300 model naming conventions are shown in Table 1-3. The computer model designation is composed of a group of characters that define each model's features.

**Table 1-3
Compaq Armada V300
Model Naming Convention**

Key

A	V	3		C1	500	T4X	6	D	M	64	58	N	S	F
1	2	3	4	5-6	7-9	10-12	13-14	15	16	17-19	20-21	22	23	24

KEY	DESCRIPTION	OPTIONS		
1	Brand designator	A = Armada		
2	Segment designator	V = Versatility		
3	Series	3 = 300		
4	Blank			
5-6	Processor type	C1 = Intel Celeron 1		
7-9	Processor speed	500 = 500 MHz	466 = 466 MHz	400 = 400 MHz
10	Panel type	T = TFT	H=HPA	
11	Panel size	4 = 14.x"	3 = 13.x"	2 = 12.x"
12	Panel resolution	X = XGA	S= SVGA	
13-14	Hard drive size (in GB, 1-2 digits)	6 = 6.0 GB	4 = 4.3 GB	
15	Optical drive	D = 24X Max CD-ROM drive		
16	Integrated communication	M = Mini PCI V.90 modem	C = NIC/modem combo	0 = none
17-19	RAM (in MB, 2-3 digits)	64 = 64 MB	32 = 32 MB	
20-21	Operating system	98 = Windows 98	N4 = Windows NT 4.0	
		58 = Windows 95/98 dual install*	N2 = Windows NT 4.0/2000 dual install	
22	NAFTA	N = NAFTA		
23	Pointing device	P = TouchPad		
24	Security			

* End user must make a one-time selection between Windows 95 and Windows 98. If end user desires rejected product(s) after selection is made, end user must acquire and pay for rejected product(s) separately.

**Table 1-4
Compaq Armada V300
Computer Models**

1	2	3	4	5-6	7-9	10	11	12	13-14	15	16	17-19	20-21	22	23	24	SKU#	Config. Code
A	V	3		C1	500	T	4	X	6	D	O	58	64		P		163308-XX2 ¹	DVR1
A	V	3		C1	500	T	4	X	6	D	O	N4	64		P		163308-XX6 ¹	DVR3
A	V	3		C1	500	T	4	X	6	D	M	58	64		P		163309-XX2 ¹	DVR4
A	V	3		C1	500	T	4	X	6	D	M	58	64	N	P		163309-XX3 ¹	DVR5
A	V	3		C1	500	T	4	X	6	D	M	N4	64		P		163309-XX6 ¹	DVR6
A	V	3		C1	500	T	4	X	6	D	M	N4	64	N	P		163309-XX7 ¹	DVR7
A	V	3		C1	500	T	4	X	6	D	C	58	64		P		163310-XX2 ¹	DVR8
A	V	3		C1	500	T	4	X	6	D	C	N4	64		P		163310-XX6 ¹	DVR9
A	V	3		C1	466	T	4	X	4	D	C	58	64		P		158984-XX2 ¹	DJD3
A	V	3		C1	466	T	4	X	4	D	C	N4	64		P		158984-XX6 ¹	DJD4
A	V	3		C1	466	T	4	X	4	D	O	58	64		P		117734-XX2 ¹	CXX1
A	V	3		C1	466	T	4	X	4	D	O	98	64		P		117734-XX4 ¹	CXX2
A	V	3		C1	466	T	4	X	4	D	O	N4	64		P		117734-XX6 ¹	CXX3
A	V	3		C1	466	T	4	X	4	D	M	58	64		P		117735-XX2 ¹	CXX4
A	V	3		C1	466	T	4	X	4	D	M	58	64	N	P		117735-XX3 ¹	CXX5
A	V	3		C1	466	T	4	X	4	D	M	N4	64		P		117735-XX6 ¹	CXX8
A	V	3		C1	466	T	4	X	4	D	M	N4	64	N	P		117735-XX7 ¹	CXX9
A	V	3		C1	466	H	3	S	6	D	O	58	32		P		163199-XX2 ²	DVP1
A	V	3		C1	466	H	3	S	6	D	O	N4	32		P		163199-XX6 ²	DVP3
A	V	3		C1	466	H	3	S	6	D	M	58	32		P		163229-XX2 ²	DVP4
A	V	3		C1	466	H	3	S	6	D	M	58	32	N	P		163229-XX3 ²	DVP5
A	V	3		C1	466	H	3	S	6	D	M	N4	32		P		163229-XX6 ²	DVP6
A	V	3		C1	466	H	3	S	6	D	M	N4	32	N	P		163229-XX7 ²	DVP7
A	V	3		C1	466	H	3	S	6	D	C	58	32		P		163304-XX2 ²	DVP8
A	V	3		C1	466	H	3	S	6	D	C	N4	32		P		163304-XX6 ²	DVP9

continued

Table 1-4 *continued*

1	2	3	4	5-6	7-9	10	11	12	13-14	15	16	17-19	20-21	22	23	24	SKU#	Config. Code
A	V	3		C1	466	T	2	S	6	D	0	58	64		P		163305-XX2 ²	DVQ1
A	V	3		C1	466	T	2	S	6	D	0	N4	64		P		163305-XX6 ²	DVQ3
A	V	3		C1	466	T	2	S	6	D	M	58	64		P		163306-XX2 ²	DVQ4
A	V	3		C1	466	T	2	S	6	D	M	58	64	N	P		163306-XX3 ²	DVQ5
A	V	3		C1	466	T	2	S	6	D	M	N4	64		P		163306-XX6 ²	DVQ6
A	V	3		C1	466	T	2	S	6	D	M	N4	64	N	P		163306-XX7 ²	DVQ7
A	V	3		C1	466	T	2	S	6	D	C	58	64		P		163307-XX2 ²	DVQ8
A	V	3		C1	466	T	2	S	6	D	C	N4	64		P		163307-XX6 ²	DVQ9
A	V	3		C1	400	T	2	S	4	D	C	58	64		P		158983-XX2 ²	DJD3
A	V	3		C1	400	T	2	S	4	D	C	N4	64		P		158983-XX6 ²	DJD4
A	V	3		C1	400	T	2	S	4	D	0	58	64		P		117732-XX2 ²	CXW1
A	V	3		C1	400	T	2	S	4	D	0	98	64		P		117732-XX4 ²	CXW2
A	V	3		C1	400	T	2	S	4	D	0	N4	64		P		117732-XX6 ²	CXW3
A	V	3		C1	400	T	2	S	4	D	M	58	64		P		117733-XX2 ²	CXW4
A	V	3		C1	400	T	2	S	4	D	M	58	64	N	P		117733-XX3 ²	CXW5
A	V	3		C1	400	T	2	S	4	D	M	N4	64		P		117733-XX6 ²	CXW8
A	V	3		C1	400	T	2	S	4	D	M	N4	64	N	P		117733-XX7 ²	CXW9
A	V	3		C1	400	H	2	S	4	D	0	58	32		P		117730-XX2 ²	CXV1
A	V	3		C1	400	H	2	S	4	D	0	98	32		P		117730-XX4 ²	CXV2
A	V	3		C1	400	H	2	S	4	D	0	N4	32		P		117730-XX6 ²	CXV3
A	V	3		C1	400	H	2	S	4	D	M	58	32		P		117731-XX2 ²	CXV4
A	V	3		C1	400	H	2	S	4	D	M	58	32	N	P		117731-XX3 ²	CXV5
A	V	3		C1	400	H	2	S	4	D	M	N4	32		P		117731-XX6 ²	CXV8
A	V	3		C1	400	H	2	S	4	D	M	N4	32	N	P		117731-XX7 ²	CXV9

¹ 9-cell Lithium Ion main battery pack

² 6-cell Lithium ion main battery pack

Features

The computer has the following features:

- The following processors are available, varying by computer model:
 - The Armada E500 features an Intel Pentium III 700-, 650-, 600-, 500- or 450-MHz processor or Intel Pentium II 400- or 366-MHz processor, with 256-KB integrated cache, depending on computer model.
 - The Armada V300 features an Intel Celeron 2 500-, 466- or 400-MHz processor, with 128-KB integrated L2 cache, varying by computer model.
- ATI RAGE LT Pro, 4-MB SGRAM (synchronous graphics)
- The following standard memory is available, varying by computer model:
 - The Armada E500 is equipped with 64-MB high-performance Synchronous DRAM (SDRAM), expandable to 512 MB.
 - The Armada V300 is equipped with 64- or 32-MB high-performance SDRAM, expandable to 512 MB.
- Microsoft Windows 95, Windows 98, Windows NT Workstation 4.0, or Windows 2000 preinstalled
- The following displays are available, varying by computer model:
 - The Armada E500 features a 15.0- or 14.1- inch, XGA, TFT (1024 × 768), 13.3-inch, XGA, TFT (1024 × 768) or 12.1-inch, SVGA, TFT (800 × 600) display, all with over 16.8 million colors.
 - The Armada V300 features a 14.1- inch XGA TFT (1024 × 768), 13.3-inch SVGA HPA (800 × 600), 12.1-inch SVGA TFT (800 × 600), or 12.1-inch SVGA STN (800 × 600) display, all with over 16.8 million colors.
- The following keyboards are available, varying by computer model:
 - The Armada E500 supports a TouchPad or pointing stick keyboard.
 - The Armada V300 is equipped with a TouchPad keyboard.

- Mini PCI 56K V.90 modem, or optional Mini PCI V.90 modem plus 10/100 NIC combination card
- The following PC Card features are available, varying by computer model:
 - The Armada E500 features two Type II PC Card slots with support for both 32-bit CardBus and 16-bit PC Cards; Zoomed video is supported in the bottom slot.
 - The Armada V300 features one Type II PC Card slot with support for both 32-bit CardBus and 16-bit PC Cards.
- External AC adapter with power cord
- The following battery packs are available, varying by computer model:
 - The Armada E500 supports a 9- or 6-cell Lithium ion (Li ion) primary battery pack in the battery bay or DualBay, and a 6-cell Li ion MultiBay battery pack in the MultiBay; supporting up to three battery packs in the computer at one time.
 - The Armada V300 supports a 9- or 6-cell Li ion primary battery pack in the battery bay and a 6-cell Li ion MultiBay battery pack in the MultiBay.
- The following hard drives are available, varying by computer model:
 - The Armada E500 supports 18.0-, 12.0-, 6.0-, or 4.3-GB high-capacity SMART hard drives with DriveLock security and Prefailure Warranty.
 - The Armada V300 supports a 6.0- or 4.3-GB high-capacity SMART hard drive with DriveLock security and Prefailure Warranty.
- Flexible MultiBay that accommodates a 24X MAX CD-ROM drive, DVD-ROM drive, SuperDisk LS-120 drive, 6-cell Li ion MultiBay battery pack, or secondary hard drive (when used with a Hard Drive MultiBay Adapter).
- Connectors for parallel, serial, audio in/out, external monitor, universal serial bus, external keyboard, and AC power
- Stereo speakers providing Compaq PremierSound 16-bit stereo sound

1.2 Intelligent Manageability

Intelligent Manageability consists of preinstalled software tools for the computer and Compaq servers that assist in tracking, troubleshooting, protecting, and maintaining the computer. It provides the following functions:

- **Asset Management:** provides detailed configuration and diagnostic information.
- **Fault Management:** prevents, predicts, and alerts of impending hardware problems.
- **Security Management:** protects unauthorized access to data and components.
- **Configuration Management:** optimizes the computer by providing the latest drivers, utilities, and software, which are available on CD ROM and the Compaq Web site at www.compaq.com/support/portables.

NOTE: For further help with Intelligent Manageability, select Start → Compaq Information Center → Intelligent Manageability

Accessing the Web Agent

The computer may have a preinstalled Web Agent that allows computer configuration information to be viewed using Web technology. To access this feature, select Start → Compaq Information Center → Insight Web Management.

If the computer does not have a preinstalled Web Agent, it can be downloaded from the Compaq Web site at www.compaq.com.

Asset Management

Asset Management enables component information to be retrieved when on the road or connected to the network.

Asset Management also enables the network administrator to remotely retrieve information from any Compaq computer connected to the network. The information can be used to assist in tracking and maintaining the computer and its components. It provides the following information:

- **Inventory information**—The network administrator can retrieve information about the computer over the network by using Compaq Insight Manager or any PC management tool provided by Compaq Solution Partners. Asset control information retrieved from the computer includes:
 - Manufacturer, model, and serial number of Compaq computers, monitors, hard drives, battery packs, memory boards, processor speeds, and operating systems
 - System board and ROM revision levels
 - BIOS settings
- **Diagnostic information**—Diagnostics for Windows includes information on hard drives, ports, video, sound, and other components. This application also allows multi-threaded tests to be run on hardware components. If problems are found, recommendations are provided.

All of the above information can be viewed, printed, or saved.

Fault Management

Fault Management features minimize downtime and data loss by monitoring system performance and generating the following alerts:

- **Hard drive alert**—provides 72-hour advance warning of impending hard drive problems and can automatically start optional backup software.
- **System temperature alert**—reports overheating. As the system temperature rises, this feature first adjusts fan speed and other cooling components, then displays an alert, then shuts down the system.
- **Battery pack alert**—reports charging problems and battery pack failure.
- **Monitor alert**—diagnoses and displays external monitor operational problems.
- **Memory alert**—reports memory board configuration changes when a memory board is removed, added, or reconfigured. It also provides the previous and current configurations for comparison.

The alerts work with or without network connection. If the computer is not connected to the network, the network administrator cannot receive alerts from the computer.

Fault Management Alerts

Alerts can be enabled, disabled, and tested, and software can be set to back up information whenever a hard drive alert occurs.

- While the computer is connected to a network, alerts pop up on the computer display and are simultaneously reported to the network console.
- System temperature alert—reports overheating. As the system temperature rises, this feature first adjusts fan speed and other cooling components, then displays an alert, then shuts down the system.

NOTE: A battery charging problem alert is reported only on the computer display.

- When the computer is not connected to a network, the user will receive a local alert.
- To set alerts, select the Intelligent Manageability icon in the system tray.

Security Management

Security Management features customize system security.

- **Power-On and Setup Passwords**—prevent unauthorized access to information and computer configuration.
- **DriveLock**—prevents unauthorized access to hard drives.
- **Device disabling**—prevents unauthorized data transfer through modems, serial ports, parallel ports, and infrared ports on the computer and an optional docking station.
- **QuickLock/QuickBlank**—locks the keyboard and clears the screen.
- **Ownership Tag**—displays ownership information during system restart.

Configuration Management

Configuration Management optimizes software upgrade and customer support procedures. Compaq provides support software to optimize the performance of the computer. This support software is accessible through a monthly CD-ROM subscription. Support software can also be downloaded from the Compaq Web site at www.compaq.com/support/portables.

Managing Power

The computer comes with a collection of power management features that allow battery operating time to be extended and power to be conserved. Use power management to monitor most computer components such as the hard drive, processor, and display.

Accessing Power Management

- In Windows 95, select Start → Settings → Control Panel → Power to view or adjust settings in Power Properties.
- In Windows NT 4.0, select Compaq Power instead of Power
- In Windows 98, select Power Management instead of Power.

Power Management Levels

To extend the life of batteries, use the Battery Conservation tab in Power Properties.

- If Windows 95 is running, select Start → Settings → Control Panel → Power to access Power Properties.
- In Windows NT 4.0, select Compaq Power instead of Power.
- In Windows 98, select Power Management instead of Power.

The level of battery conservation or the selection of preset power management levels can be customized.

1.3 Computer External Components

The external components on the display and left side of the computer are shown in Figure 1-2 and described in Table 1-5.

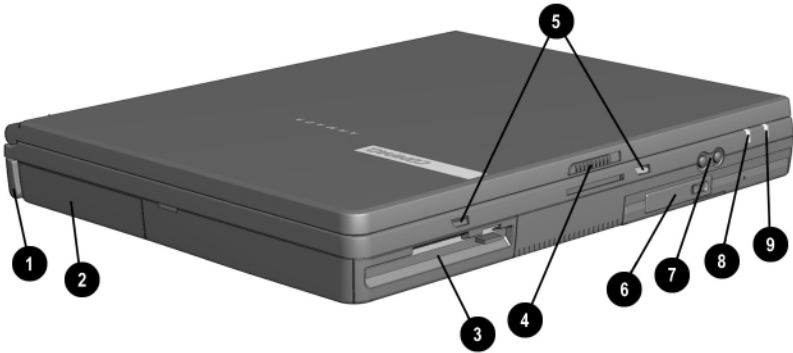

Figure 1-2. *Display and Left Side Components*

Table 1-5
Display and Left Side Components

Item	Component	Function
1	Tilt feet (2)	Tilt the computer for ease of use.
2	Battery bay	Accepts a 9- or 6-cell Lithium ion (Li ion) primary battery pack.
3	Armada E500: DualBay Armada V300: Fixed diskette drive	Accepts a removable diskette drive or 9- or 6-cell Li ion primary battery pack. Accepts diskettes.
4	Display release latch	Opens the computer.
5	Audio bass port	Enhances stereo sound.
6	MultiBay	Accepts the following MultiBay devices: CD-ROM drive, DVD-ROM drive, hard drive (in Hard Drive MultiBay Adapter), SuperDisk LS-120 Drive, 6-cell Li ion MultiBay battery pack.
7	Volume buttons	Adjust the volume of the stereo speakers.
8	Power/suspend light (green)	On: Power is turned on. Off: Power is turned off. Blinking: Computer is in Suspend.* NOTE: The power/suspend light also blinks if a battery pack that is the only source of power available to the computer reaches a critical low-battery condition while Hibernation is disabled.
9	Battery light (green)	On: A battery pack is charging. Off: No battery packs are changing. Blinking: A battery pack that is the only available power source has reached a low-battery condition.

*In Windows 98 the term Standby replaces the term Suspend.

The external components on the right side of the computer are shown in Figure 1-3 and are described in Table 1-6.

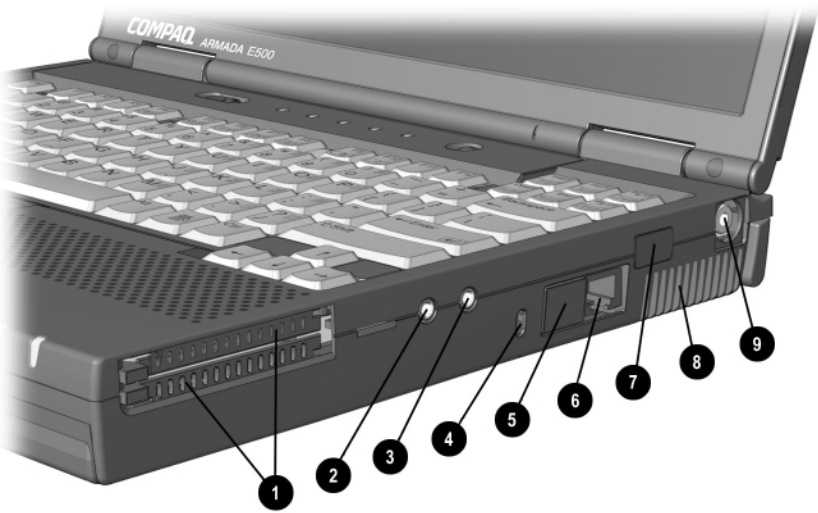

Figure 1-3. Right Side Components

Table 1-6
Right Side Components

Item	Component	Function
1	PC Card slots*	Supports 32-bit (CardBus) and 16-bit PC Cards. * The Armada E500 has two PC Card slots; the Armada V300 has only one PC Card slot.
2	Stereo speaker/headphone jack	Connects stereo speakers, headphones, or headset. This jack is driven by an amplifier and has volume control. The internal computer speakers are turned off when external speakers or headphones are plugged into this jack.
3	Mono microphone jack	Connects a mono microphone, disabling the built-in microphone.
4	Security cable slot	Accepts an optional security cable to secure the computer to a fixed object to prevent theft.
5	RJ-11 jack (internal modem models only)	Connects the modem cable to an internal modem. NOTE: A modem cable is included with internal modem models.
6	RJ-45 jack (internal network interface card models only)	Connects the network cable.
7	Infrared port	Provides wireless communication between the computer and another infrared-equipped device using an infrared beam.
8	Air vent	Provides for airflow to cool internal components.
9	Composite TV connector	Connects a television, VCR, camcorder, or overhead projector.

The external components on the rear of the computer are shown in Figure 1-4 and described in Table 1-7.

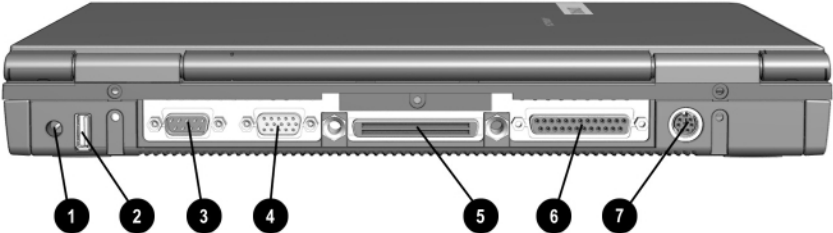

Figure 1-4. Rear Components

Table 1-7
Rear Components

Item	Component	Function
1	AC Adapter connector	Connects the AC power adapter.
2	Universal Serial Bus (USB) connector	Connects USB devices, such as cameras for video conferencing, or hubs which connect multiple USB devices. The USB connector is a powered hub. When running Windows 95 or higher or Windows NT, any combination of up to five powered or unpowered hubs can be connected in any sequence, as long as two unpowered hubs are not connected next to each other. When running a lower version of Windows or Windows NT, or if using a different operating system, up to two hubs can be connected.
3	External monitor connector	Connects an optional external monitor, overhead projector, or TV adapter.
4	Serial connector	Connects optional serial devices, such as a mouse.
5	Docking connector	Connects the computer to the expansion base, convenience base, or port replicator.
6	Parallel connector	Connects an optional parallel device, such as a printer.
7	Keyboard/mouse connector	Connects an optional full-sized keyboard or a mouse. Both external mouse and computer pointing device are active. An optional splitter/adaptor allows both an external keyboard and mouse to be used at the same time.

Computer keyboard components are shown in Figure 1-5 and described in Table 1-8.

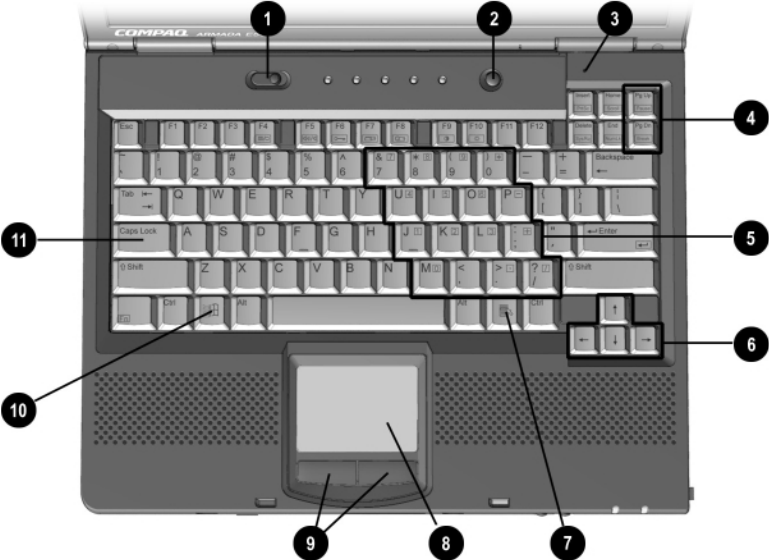

Figure 1-5. Keyboard Components

Table 1-8
Keyboard Components

Item	Component	Function
1	Power switch	Turns the computer on or off or exits Suspend ¹ .
2	Suspend button	Initiates or exits Suspend ¹ . When pressed with the Fn key, initiates Hibernate.
3	Display switch	Turns off the display if it is closed while the computer is turned on.
4	Page up and page down keys	Move to the previous or next screen.
5	Embedded numeric keypad	Converts keys to numeric keypad.
6	Cursor-control keys	Move the cursor around the screen.
7	Windows application key	Displays shortcut menu for item beneath mouse cursor.
8	TouchPad (TouchPad models only)	Moves the mouse cursor, selects, and activates.
9	Left and right TouchPad buttons (TouchPad models only)	Function like the left and right mouse buttons on an external mouse.
10	Microsoft logo key	Displays the Windows Start menu.
11	Caps lock key	Turns on the caps lock function.

Additional computer keyboard components are shown in Figure 1-6 and described in Table 1-9.

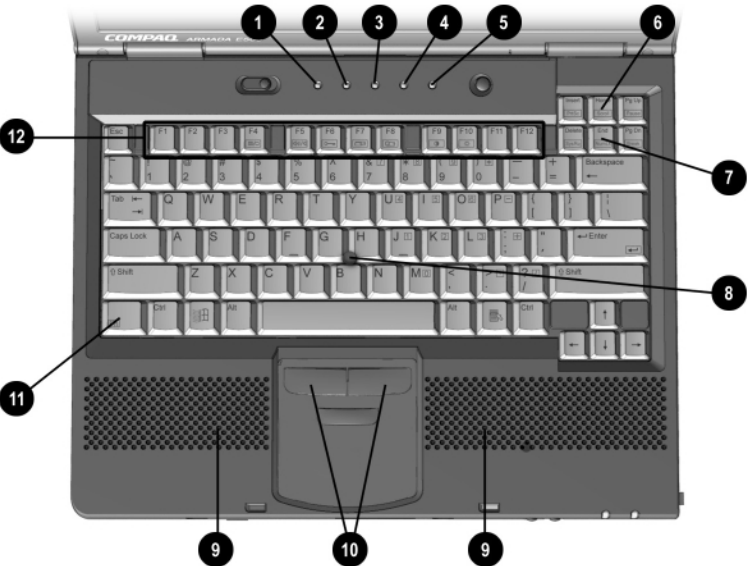

Figure 1-6. Keyboard Components (continued)

Table 1-9
Keyboard Components (continued)

Item	Component	Function
1	Hard drive light (green)	Turns on when the hard drive is being accessed.
2	MultiBay light (green)	Turns on when a MultiBay device is being accessed or a battery pack in the MultiBay is charging or waiting to be charged.
3	Num lock light	Turns on when the numeric lock function is on.
4	Caps lock light	Turns on when the caps lock function is on.
5	Scroll lock light	Turns on when the scroll function is on.
6	Scroll lock key	Turns on the scroll function.
7	Num lock key	Turns on the numeric lock function.
8	Pointing stick	Moves the mouse cursor.
9	Stereo speakers	Produce stereo sound.
10	Left and right mouse buttons	Function like left and right mouse buttons on an external mouse.
11	Fn key	Used with hotkeys to perform preset hotkey functions.
12	F1 through F12 function keys	Perform preset functions.

The external components on the bottom of the computer are shown in Figure 1-7 and are described in Table 1-10.

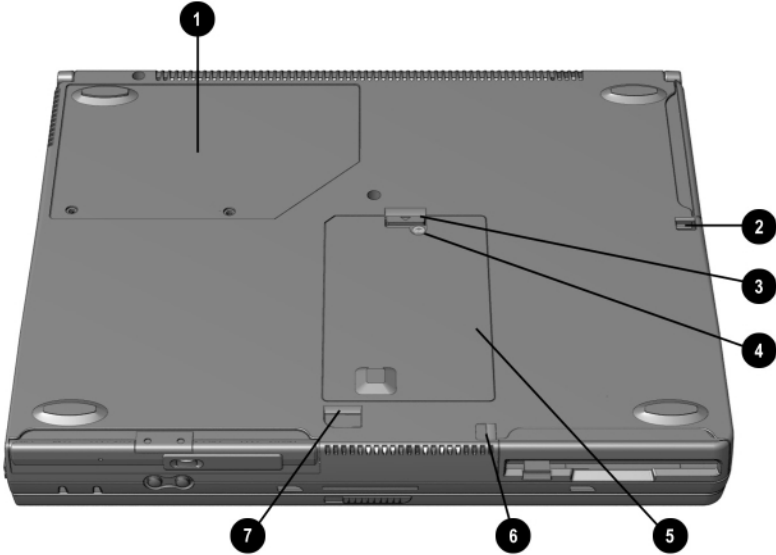

Figure 1-7. Bottom Components

Table 1-10
Bottom Components

Item	Component	Function
1	Mini PCI slot cover	Contains the mini PCI modem or network interface card.
2	Battery release latch	Releases the battery from the battery bay.
3	Hard drive cover release latch	Releases the hard drive cover.
4	Hard drive cover screw	Secures the hard drive cover.
5	Hard drive cover	Covers the hard drive bay.
6	Diskette drive release latch	Releases the device from the DualBay on the Armada E500. Releases the diskette drive bezel from the Armada V300.
7	MultiBay release latch	Releases the MultiBay device.

1.4 Design Overview

This section presents a design overview of key parts and features of the computer. Refer to Chapter 3 for the illustrated parts catalog and Chapter 5 for removal and replacement procedures.

The system board provides the following device connections:

- Memory expansion board
- Hard drive
- Display
- Keyboard/TouchPad or pointing stick
- Audio
- Intel Pentium III, II, or Celeron processors
- Fan
- PC Cards
- Modem or modem/NIC

The Armada E500 and Armada V300 computers use an electrical fan for ventilation. The fan is controlled by a temperature sensor and is designed to turn on automatically when high temperature conditions exist. These conditions are affected by high external temperatures, system power consumption, power management/battery conservation configurations, battery fast charging, and software applications. Exhaust air is displaced through the ventilation grill located on the right side of the computer.



CAUTION: To properly ventilate the computer, allow at least a 3-inch (7.6 cm) clearance on the left and right sides of the computer.

chapter 2

TROUBLESHOOTING

Follow these basic steps when beginning the troubleshooting process:

1. Complete the preliminary steps listed in Section 2.1.
2. Run the Power-On Self-Test (POST) as described in Section 2.3.
3. Run Computer Setup as described in Section 2.5.
4. If you are unable to run POST or if the problem persists after running POST, perform the recommended actions described in the diagnostic tables in Section 2.5.

Follow these guidelines when troubleshooting:

Complete the recommended actions in the order in which they are given.

- Repeat POST after each recommended action until the problem is resolved and the error message does not return.
- When the problem is resolved, stop performing the troubleshooting steps and do not complete the remaining recommended actions.
- Refer to Chapter 5 for recommended removal and replacement procedures.
- If the problem is intermittent, check the computer several times to verify that the problem is solved.

The following table describes the troubleshooting actions:

If You Want To:	Then Run:
Check for POST error messages	POST
Perform any of the following: <ul style="list-style-type: none">■ Check the system configuration■ Set the system power management parameters■ Return the system to its original configuration■ Check system configuration of installed devices	Computer Setup

2.1 Preliminary Steps

IMPORTANT: Use AC power when running POST or Computer Setup. A low battery condition could initiate Hibernation and interrupt the test.

Before running POST, complete the following steps:

1. Obtain established passwords. If you must clear the passwords, go to Section 2.2.
2. Ensure that the battery pack is installed in the computer and the power cord is connected to the computer and plugged into an AC power source.
3. Turn on the computer.
4. If a power-on password has been established, type the password and press Enter.
5. Run Computer Setup (Section 2.5). If a Setup password has been established, type the password and press Enter.
6. Turn off the computer and all external devices.
7. Disconnect external devices that you do not want to test. If you want to use the printer to log error messages, leave it connected to the computer.

NOTE: If a problem only occurs when an external device is connected to the computer, the problem could be with the external device or its cable. Isolate the problem by running POST with and without the external device connected.

8. Use Compaq Utilities and loopback plugs in the serial and parallel connectors if you plan to test these ports.

Follow these steps to run Compaq Utilities:

- a. If you are running Compaq Utilities from the hard drive, turn on or restart the computer. Press F10 when the cursor appears in the upper-right corner of the screen. If you do not press F10 in time, restart the computer and try again.

If you are running Compaq Utilities from diskette, insert the Compaq Utilities diskette in drive A. Turn on or restart the computer.

- b. Press **Enter** to accept OK.
- c. Select Prompted Diagnostics.
- d. After “Identifying System Hardware” completes, select Interactive Testing and follow the instructions on the screen.

2.2 Clearing Passwords

1. Turn off the computer.
2. Disconnect the AC Adapter.
3. Remove all battery packs.
4. Remove the switch cover (refer to Chapter 5, Section 5.8).
5. Disconnect the Real Time Clock (RTC) battery (Section 5.9).
6. Wait five minutes.
7. Reconnect the RTC battery.
8. Replace the switch cover.
9. Reconnect the AC Adapter. Do not reinstall any battery packs yet.
10. Turn on the computer.

NOTE: Remember to set the date and time the next time the computer is turned on.

2.3 Power-On Self-Test (POST)

The Power-On Self-Test (POST) is a series of tests that run every time the computer is turned on. POST verifies that the system is configured and functioning properly.

To run POST, complete the following steps:

1. Complete the preliminary steps (Section 2.1).
2. Turn on the computer.

If POST does not detect any errors, the computer beeps once or twice to indicate that POST has run successfully. The computer boots from the hard drive or from a bootable diskette if one is installed in the diskette drive.

2.4 POST Error Messages

If the system is not functioning well enough to run POST, or if the display is not functioning well enough to show POST error messages, refer to the Troubleshooting tables in Section 2.6.

If POST detects an error, one of the following events occur:

- A message with the prefix "WARNING" appears, informing you where the error occurred. The system pauses until you press **F1** to continue.
- A message with the prefix "FATAL" appears, informing you where the error occurred. After the message, the system emits a series of beeps, then stops.

The system emits a series of beeps, then stops.

Warning messages indicate that a potential problem, such as a system configuration error, exists. When **F1** is pressed, the system should resume. You should be able to correct problems that produce WARNING messages.

If you receive one of the error messages listed below, follow the recommended action.

Table 2-1
Warning Messages

Message	Description	Recommended Action
CMOS checksum invalid, run SCU	CMOS RAM information has been corrupted.	Run Computer Setup (Section 2.5) to reinitialize CMOS-RAM.
CMOS failure, run SCU	CMOS RAM has lost power.	Run Computer Setup (Section 2.5) to reinitialize CMOS-RAM.
Diskette controller error	The diskette drive controller failed to respond to the recalibrate command.	If there is no diskette drive in the system, run Computer Setup (Section 2.5) to properly configure the CMOS-RAM to show no diskette drive present. If the problem persists, or if a diskette drive is present, complete these steps until the problems are solved: <ol style="list-style-type: none">1. Check diskette drive connections.2. Replace diskette drive.3. Replace system board.
Diskette track 0 failed	The diskette drive cannot read track 0 of the diskette in the drive.	Try another diskette. If the problem persists, you may need to replace the diskette drive.
Hard disk controller error	The hard drive controller failed to respond to the reset command.	Check the drive parameters. Turn off the system and check all related connections.
Keyboard controller failure	The keyboard failed the self-test command.	Replace the system board.

Continued

Table 2-1 *continued*

Message	Description	Recommended Action
Keyboard failure	The keyboard failed to respond to the RESET ID command.	Replace the keyboard. If the problem persists, replace the system board.
No interrupts from Timer 0	The periodic timer interrupt is not occurring.	Replace the system board.
ROM at xxxx (LENGTH yyyy) with nonzero checksum (zz)	An illegal adapter ROM was located at the specified address.	Check the external adapter (such as a video card) to determine if it is causing the conflict.
Time/Date corrupt - run SCU	The time and date stored in the real time clock (RTC) have been corrupted, possibly by a power loss.	<ol style="list-style-type: none">1. Run Computer Setup (Section 2.5).2. If problem persists, replace RTC battery.3. If problems persists, replace system board.
Hard disk xx failure (or error)	A failure or an error occurred when trying to access the hard drive.	<ol style="list-style-type: none">1. Run ScanDisk.2. Check disk in DOS and Windows 95.

Fatal errors emit a beep and may display a FATAL message. Fatal errors indicate severe problems, such as a hardware failure. Fatal errors do not allow the system to resume. Some of the Fatal error beep codes are listed at the end of this section.

Table 2-2
Fatal Error Messages

Message	Description	Beep code
CMOS RAM test failed	A walking bit test of CMOS RAM location 0E (Hex) - 3F (Hex) failed.	3
DMA controller faulty	A sequential read/write of the transfer count and transfer address registers within the primary and secondary DMA controllers failed.	4
Faulty DMA page registers	A walking bit read/write of the 16 DMA controller page registers starting at location 80 Hex failed.	0
Faulty refresh circuits	A continuous read/write test of port 61h found that bit 4 (Refresh Detect) failed to toggle within an allotted amount of time.	1
Interrupt controller failed	A sequential read/write of various Interrupt Controller registers failed.	5
ROM checksum incorrect	A checksum of the ROM BIOS does not match the byte value at F000:FFFF.	2
RAM error at location xxxx	RAM error occurred during memory test.	None

*Beep codes are defined in Table 2-3.

Table 2-3
Fatal Error Beep Codes

Beep Code	Beep Sequence	Description	Recommended Action
0	S-S-S-P-S-S-L-P	The DMA page registers are faulty.	Replace system board.
1	S-S-S-P-S-L-S-P	The refresh circuitry is faulty.	
2	S-S-S-P-S-L-L-P	The ROM checksum is incorrect.	
3	S-S-S-P-L-S-S-P	The CMOS RAM test failed.	
4	S-S-S-P-L-S-L-P	The DMA controller is faulty.	
5	S-S-S-P-L-L-S-P	The interrupt controller failed.	
6	S-S-S-P-L-L-L-P	The keyboard controller failed.	
7	S-S-L-P-S-S-S-P	Graphics adapter is faulty.	
8	S-S-L-P-S-S-L-P	Internal RAM is faulty.	Replace memory board or system board if memory on system board is faulty.

NOTE: S = Short, L = Long, P = Pause

2.5 Compaq Utilities

Compaq Utilities contain several functions that

- Determine if various computer devices are recognized by the system and are operating properly.
- Provide information about the system once it is configured.

Compaq Utilities include the following programs:

- Computer Setup
- Compaq Diagnostics

To access Compaq Utilities:

1. Turn on or restart the computer by clicking Start→Shut Down→Restart the computer.
2. Press **F10** when the blinking cursor appears in the upper-right corner of the display.
3. Select a menu option.

Selecting Computer Setup or Compaq Diagnostics for Windows

The computer features two system management utilities:

- Computer Setup is a system information and configuration utility that can be used even when your operating system is not working or will not load. It includes custom settings that are not available in Windows.

To configure a device in Windows NT 4.0, you must use Computer Setup.

- Compaq Diagnostics for Windows is a system information and diagnostic utility that is used within the Windows operating system. Use Compaq Diagnostics for Windows to test system components and to display system information whenever possible.

To configure a device in Windows 95 or 98 use the operating system itself. Windows 95 and 98 can be used to add and remove programs, and provide Wizards to ensure proper device drivers are installed. Diagnostics for Windows is NOT a configuration tool and might only test devices that are properly configured by the operating system.

NOTE: It is not necessary to configure a device connected to a USB connector on the computer or an optional docking base.

Using Computer Setup

All information and settings in Computer Setup are accessed from the File, Security, or Advanced menus.

NOTE: Your settings in Computer Setup are not affected by updating the system ROM.

To view information or change a setting in Computer Setup:

1. Turn on or restart the computer. When the blinking cursor appears in the upper-right corner of the screen, press **F10**.
 - To change the language, press **F2**.
 - To view navigation information, press **F1**.
 - To return to the Computer Setup menu from anywhere in Computer Setup, press **Esc**.
2. Select the File, Security, or Advanced menu.
3. To close Computer Setup and restart the computer
 - Select File→Ignore Changes and Exit, then press **Enter**.
 - or
 - Select File→Save Changes and Exit, then press **Enter**.
4. To confirm your choice, press **F10**.

File Menu

Begin here	To do this
System information	<ul style="list-style-type: none">■ View identification information about the computer, docking base, and battery packs.■ View specification information about the processor, memory and cache size, and ROM date and family.
Save to floppy	Save system configuration to a diskette.
Restore from floppy	Restore system configuration from a diskette. (The diskette contains your personal configuration, so you should restore from the diskette before using the Quick Restore CD-ROM.)
Restore defaults	Replace configuration settings in Computer Setup with factory default settings. (Identification information is retained.)
Ignore changes and exit	Cancel changes entered during the current Computer Setup session, then exit and restart the computer.
Save changes and exit	Save changes, then exit and restart the computer.

Security Menu

Begin here	To do this
Setup password	Enter, change, or delete a setup password.
Power-on password	Enter, change, or delete a power-on password.
Password options	Enable/disable: <ul style="list-style-type: none">■ QuickLock/QuickBlank.■ Lock keyboard and pointing stick or touchpad at startup. (These features can be enabled only when a power-on password is set.)
DriveLock passwords	Enter, change, or delete a DriveLock password.
Device security	Enable/disable <ul style="list-style-type: none">■ Ports or diskette drives.■ Diskette write.■ CD-ROM or diskette startup. NOTE: Settings for a DVD-ROM can be entered in the CD-ROM field.
System IDs	Enter identification numbers for the computer, a docking base, and battery packs.

Advanced Menu

Begin here	To do this
Language (or press F2)	Change the Computer Setup language.
Boot Options	<p>Enable/disable</p> <ul style="list-style-type: none">■ QuickBoot, which starts the computer more quickly by eliminating some startup tests. (If you suspect a memory failure and want to test memory automatically during startup, you may want to disable QuickBoot.) <p>MultiBoot, which enables you to set a startup sequence that can include any drives in the system.</p>
Device Options	<ul style="list-style-type: none">■ Enable/disable the embedded numeric keypad at startup.■ Enable/disable multiple standard pointing devices at startup. When this feature is disabled, only one pointing device is activated at startup.■ Enable/disable USB legacy support for one USB mouse and one USB keyboard. (When USB legacy support is enabled, the keyboard and mouse work without a loaded USB driver.)■ Set an optional external monitor or overhead projector connected to a video card in a docking base as the primary device. (When the computer display is set as secondary, the computer must be shut down before undocking.)■ Set video-out mode to NTSC (default), NTSC-J, PAL, or PAL-M. <p>Change the parallel port mode to or from EPP, standard, bidirectional, or ECP.</p>

Using Compaq Diagnostics for Windows

1. Access Compaq Diagnostics for Windows by selecting Start→Settings→Control Panel→Compaq Diagnostics.
2. To select a category, choose one of two methods:
 - Select the Categories menu, then select a category from the drop-down list.
 - Select a category icon on the toolbar.
3. To run diagnostic tests:
 - a) Select the Test tab.
 - b) In the scroll box, select the category or device you want to test.
 - c) Select the Quick, Complete, or Custom test type.
 - d) Select the Interactive or Unattended test mode.
 - e) Select the Begin Testing button.
 - f) View test information by selecting a report from the Status, Log, or Error tab.
4. To print the information or save it to a drive, select the File menu, then select Print or Save As.
5. To exit, select the File menu→Exit.

Factory Default Settings

**Table 2-4
Initialization**

Enable POST Memory Test	Checked (enabled)
Keyboard Num Lock	Unchecked (Off)
Hard drive boot sequence	
1	Hard drive in the computer MultiBay
2	Hard drive in the computer hard drive bay
Boot display	Auto
Language	Language of country

**Table 2-5
Ports**

Serial port	3F8, IRQ4
Infrared port	2F8, IRQ9
Parallel port	378, IRQ7
Ethernet port	300, IRQ11

Table 2-6
Power

Low Battery Warning Beep	Checked (enabled)
External Energy Saving Monitor Connected	Unchecked (not connected)
Power Management	
Enabled	While operating on battery power
Conservation Level	High
Level Definition	
High	Suspend Time: 3 minutes Hibernation Timeout: Immediate Drive Timeout: 1 minute Screen Timeout: 1 minute
Medium	Suspend Time: 5 minutes Hibernation Timeout: 1 hour Drive Timeout: 2 minutes Screen Timeout: 3 minutes
Custom	Allows the desired times to be customized. Default settings are: Suspend Time: disabled Hibernation Timeout: low battery Drive Timeout: always on Screen Timeout: always on

Table 2-7
Security

Enable QuickLock/QuickBlank	Unchecked (Disabled)
Enable Power-on Password	Unchecked (Disabled)
Disable Serial/Infrared Ports	Unchecked (Enabled)
Disable Parallel Port	Unchecked (Enabled)
Disable PC Card Slots	Unchecked (Enabled)
Setup Password	Password blank
Power-on Password	Password blank
Diskette Drives	
Disable Diskette Drives	Unchecked (Enabled)
Disable Diskette Boot	Unchecked (Enabled)

2.6 Troubleshooting Without Diagnostics

This section provides information about how to identify and correct some common hardware, memory, and software problems. It also explains several types of messages that may be displayed on the screen.

Since symptoms can appear to be similar, carefully match the symptoms of the computer malfunction against the problem description in the Troubleshooting tables to avoid a misdiagnosis.

Before Replacing Parts

When troubleshooting a problem, check the following items for possible solutions before replacing parts:

- Verify that cables are connected properly to the suspected defective parts.
- Verify that all required device drivers are installed.
- Verify that all printer drivers have been installed for each application.

Obtaining Update Information with Info Messenger

Compaq Info Messenger allows you to set a customized search of the Compaq Web site. By registering for this utility, you can stay up to date with software and hardware information specific to your system.

- Verify that cables are connected properly to the suspected defective parts.
- Select the Categories menu, then select a category from the drop-down list.
- To register, follow the instructions on the Info Messenger page. When your registration is complete, you can
 - Implement your customized search whenever you prefer from the Info Messenger page.
 - Set Info Messenger to send you the information by email as it becomes available.

Info Messenger will also inform you if there are updates to the system ROM for your computer.

Table 2-8
Solving Audio Problems

Problem	Possible Cause	Solution
Computer does not beep after the Power-On Self-Test (POST).	System beeps have been turned down.	Use the Fn+F5 hotkeys to turn up the system volume.
Internal speaker does not produce sound when an external audio source is connected to the stereo line-in jack.	Volume may be turned off or set too low.	<ul style="list-style-type: none"> ■ Adjust the overall volume with the Fn+F5 hotkeys. ■ Adjust the overall volume by pressing the Fn+F5 hotkeys. ■ Adjust the sliding mixer controls by double-clicking the speaker icon on the Windows taskbar.
	Line input may not be connected properly.	Check line input connection.
	Headphones or speakers are connected to the stereo speaker/headphone jack, which disables the internal speakers.	Disconnect the headphones or speakers to enable the internal speakers.
	Volume may be muted	Uncheck the mute box in the volume properties.
External microphone does not work.	You are using the wrong type of microphone or microphone plug for the computer.	Check to see if you are using a monophonic electret condenser microphone with a 3.5-mm plug.
	The microphone may not be connected properly.	Ensure that the microphone plug is properly connected to the mono microphone jack.

Continued

Table 2-8 *continued*

Problem	Possible Cause	Solution
External microphone does not work (continued).	Sound source not selected.	Ensure that microphone is selected as the recording source in Control Panel → Multimedia and that the recording level is adjusted.
External microphone does not work (continued).	Audio settings are not set correctly.	Check the game program's audio settings.
	Volume control on the computer is turned down.	Adjust the computer volume with the Fn+F5 hotkeys.
No sound from headphones	Volume or mixing controls set incorrectly.	■ Adjust the overall volume with the Fn+F5 hotkeys.
		■ Use the mixing features available by double-clicking the speaker icon on the Windows taskbar.
	Sound source not selected.	Verify that the sound source is selected in Control Panel → Multimedia.
	The headphones are connected to the wrong jack.	Check the connection.
Volume too low or too loud	Volume or mixing controls set incorrectly.	■ Adjust the overall volume with the Fn+F5 hotkeys. ■ Check the mixing features available by double-clicking the speaker icon on the Windows taskbar.

Table 2-9
Solving Battery/Battery Gauge Problems

Problem	Possible Cause	Solution
Computer is beeping and battery power light is blinking	Battery pack charge is low.	<ul style="list-style-type: none"> ■ Charge the battery pack by connecting to an external power source. ■ Replace the battery pack with another fully charged battery. ■ Initiate Hibernation or turn the computer off until AC power or a fully charged battery is available.
Computer battery charge light blinks to indicate low battery condition, but computer does not beep.	Volume turned down too low.	Turn up the volume using the Fn+F5 hotkeys.
Battery pack will not charge.	Battery pack was exposed to temperature extremes.	Allow time for the battery pack to return to room temperature.
	Battery pack is already charged.	No action required.
	Battery pack has exceeded its useful life cycle.	Use a different battery pack.
Computer shut down and memory was lost when replacing the battery pack.	Hibernation was not initiated before removing the battery pack.	Work is lost.
Battery charge does not last very long.	Battery is exposed to higher temperatures.	Put the computer in a cooler place and recharge the battery pack.

Continued

Table 2-9 *continued*

Problem	Possible Cause	Solution
Battery charge does not last very long (continued).	Battery is exposed to extremely cold temperatures.	Put the computer in a warmer place and recharge the battery pack. NOTE: The recommended operating temperature range for the battery is from 10°C to 40°C (50°F to 104°F). The recommended storage temperature range for the battery is from 0°C to 30°C (32°F to 86°F).
	Battery conservation is disabled or set to drain.	Reset the battery conservation level.
	An external device is draining the battery.	Turn off or remove any external device or PC Cards when not in use.
	Battery gauge may be inaccurate and require recalibration.	Recalibrate the gauge.
Date and time must be set every time computer is turned on.	The real time clock (RTC) battery has reached the end of its useful life.	Replace the RTC battery (refer to Section 5.9).
Battery gauge seems inaccurate.	The battery pack may need calibration.	Recalibrate the battery.
	The battery pack has reached the end of its useful life.	Replace the battery pack.
Battery pack is warm after charging.	Warming occurs during charging.	No action required.

Table 2-10
Solving Compact Disc and DVD-ROM Problems

Problem	Possible Cause	Solution
Drive cannot read a disc	Disc is not properly seated in the drive.	Open the loading tray, insert the disc, then close the tray.
	Disc is loaded in the loading tray upside down.	Open the loading tray, turn over the disc (label facing up), then close the tray.
	Disc has a scratch on its surface.	Insert a different disc.
CD-ROM drive or DVD-ROM drive is not detected by the computer.	Drive is not connected properly.	If you are running a version of Windows that was preinstalled by Compaq, remove the drive from the MultiBay and reinsert it.
		If you are running a version of Windows that was not preinstalled by Compaq, turn off the computer. Then remove the drive from the MultiBay and reinsert it.

Table 2-11
Solving Diskette Drive/SuperDisk LS-120 Drive Problems

Problem	Possible Cause	Solution
Drive cannot write to a diskette.	Diskette is not formatted.	Format the diskette.
	Diskette is write-protected.	Use another diskette that is not write-protected or disable the write-protect feature.
	Writing to the wrong drive.	Check the drive letter in your path statement.
	Not enough space is left on the diskette.	Save the information to another diskette.
	Drive is disabled.	Enable the proper drive through Device Manager.
System cannot start up from diskette or SuperDisk LS-120 drive.	Disable diskette write ability is turned on.	Run Computer Setup (Section 2.5). Select the Storage icon. Make sure Disable diskette write ability is not checked.
	A bootable diskette is not in the drive.	Verify that a diskette with the necessary system files is in the drive.
	Diskette bootability is disabled in Computer Setup.	Enable diskette bootability in Computer Setup, Security menu.

Table 2-12
Solving Hard Drive Problems

Problem	Possible Cause	Solution
Accessing information on the hard drive is much slower than usual.	Hard drive entered low power state due to timeout and is now exiting from it.	Wait for the system to restore the previously saved data to its state prior to initiating a low power state.
	Hard drive is fragmented/not optimized or has errors.	Run ScanDisk and Disk Defragmenter.
Hard drive does not work.	Hard drive is not seated properly.	Turn off and unplug the computer, remove the hard drive, and reinsert the hard drive.
Errors occur after starting from an additional hard drive.	Additional hard drive has not been specially prepared with necessary software.	Boot from the original hard drive or a specially prepared hard drive.
System does not recognize a hard drive.	The drive is not seated properly.	Remove, then reinsert the drive.
	The drive is damaged.	Try using the hard drive in another bay to verify that the problem is with the drive. Run ScanDisk on the drive.
	The drive was inserted while system was on or in Suspend or Hibernation.	Shut down the computer before inserting or removing a hard drive.
DriveLock settings cannot be accessed in Computer Setup.	The DriveLock settings are accessible only when you enter Computer Setup by turning on (not restarting) the computer.	Completely turn off the computer. Turn the computer back on, then run Computer Setup (Section 2.5) by pressing F10 when the blinking cursor light appears upper-right on the screen.

Table 2-13
Solving Infrared Problems

Problem	Possible Cause	Solution
Cannot communicate with another computer.	The appropriate software is not running on both computers.	Install the appropriate software on the second device, start the second device, and start the program on both computers.
	The other computer does not have an IrDA-compliant infrared port. Your Compaq computer uses the IrDA communications protocol.	Communication between infrared devices must use the same communications protocol. Check the manufacturer's instructions for connecting with infrared devices or try connecting with a device you know to be IrDA-compliant.
	The pathway between the infrared ports is obstructed, one port is more than 30 degrees (plus or minus 15 degrees off the center line) from the other, or the ports are more than one meter apart.	Remove the obstruction, align the infrared ports to within 30 degrees, and position computers within 1.5 feet (about 0.5 meter) of each other.
	There is an interrupt request (IRQ) conflict.	Check for IRQ conflicts in the Device Manager. If two devices have the same IRQ address, reassign one of the devices.
	There is a baud rate conflict.	Select the same baud rate for both computers.
	There is a conflict with the # bits.	Select the same # bits setting for both computers.
	There is a stop byte conflict.	Select the same stop byte for both computers.
	There is a parity conflict.	Select the same parity setting for both computers.

Continued

Table 2-13 *continued*

Problem	Possible Cause	Solution
Cannot transmit data.	Direct sunlight, fluorescent light, or flashing incandescent light is close to the infrared connections.	Remove the interfering light source(s).
	There is interference from other wireless devices.	Keep remote control units such as wireless headphones and other audio devices away from the infrared connections.
	There is a physical obstruction in the way.	Do not place objects that will interfere with a line-of-sight data transmission between the two units.
	One of the units was moved during data transmission.	Do not move either unit during data transmission.
	The orientation of the units is wrong.	Adjust the devices so that they point directly at each other.
	The distance between the units is too great.	Verify that devices are not more than 1.5 feet (0.5 meter) apart.
Infrared port doesn't work.	Direct sunlight, fluorescent light, or flashing incandescent light is close to the infrared connections.	Remove the interfering light source(s).
	There is interference from other wireless devices.	Keep remote control units such as wireless headphones and other audio devices away from the infrared connections.
	IR has been disabled.	Run IR configuration utility in Control Panel.

Table 2-14
Solving Keyboard Problems

Problem	Possible Cause	Solution
Screen is blank and keyboard is working.	A screen timeout has been initiated.	Press any key to refresh the screen.
	QuickLock/QuickBlank has been initiated.	To enable the keyboard and return your information to the screen, enter your power-on password.
	LCD has been disabled.	Press Fn+F4 to cycle from external monitor to internal LCD.
Embedded numeric keypad on computer keyboard is disabled.	Num Lock function is not turned on.	Press Fn+Num Lk to enable the Num Lock function and embedded numeric keypad.

Table 2-15
Solving Modem Problems

Problem	Possible Cause	Solution
Modem loses connection.	The cable connection from the phone line to the modem is loose.	Check to make sure the telephone cable is properly connected.
	Call Waiting has not been disabled.	Disable Call Waiting: <ol style="list-style-type: none"> 1. Select Start → Setting → Control Panel → select Modems. 2. From the General tab of the Modems Properties page, select Dialing Properties. From the My Locations tab of the Dialing Properties page, check the box labeled This location has call waiting. Select *70, 70#, or 1170 from the drop-down list to disable call waiting.
	There is noise or excessive traffic on the phone line.	Try connecting at a later time.
Modem not responding	Modem is not set up correctly in system BIOS.	Check the computer BIOS setup. If it requires specific settings for modems, be sure that they have been enabled.

Continued

Table 2-15 *continued*

Problem	Possible Cause	Solution
Modem does not dial correctly.	Telephone number is not entered correctly in the modem's dialing software.	<ul style="list-style-type: none">■ Make sure the telephone number you dialed is correct if you are using the dialing directory or the terminal mode.■ Dial 1 if using dialing long distance.■ The other line could be busy or not answering.■ Make sure call waiting is disabled.■ The modem may not recognize an international dial tone. Try the ATX3DT command and the telephone number.
Characters are garbled/transfer rates are slow.	There is noise in the telephone line.	<ul style="list-style-type: none">■ Check your telephone and modem cable connections. If they are a little loose, they can cause noise on the line.■ Check with your local telephone company for a phone line filter.

Continued

Table 2-15 *continued*

Problem	Possible Cause	Solution
Phone line noise causing a disconnection.	Hang-up Delay S Register (S10) set too low.	Change S10 default to 150. To set S10=150: 1. Select Start → Programs → Accessories → HyperTerminal, then go to Command Mode. 2. Type ATS10=150 and press Enter . This command causes the modem to take longer to disconnect even if there is noise on the line.
No dial tone	Phone service is not connected to the telephone wall jack.	Verify that service from the local phone company by following these steps: 1. Unplug the telephone cable from the telephone wall jack. 2. Connect a telephone to the jack, pick up the handset, and listen for a dial tone. If there is a dial tone, reconnect the modem to the telephone wall jack with the telephone cable and make sure all connections are secure. 3. If there is still no dial tone, contact your local phone company or building manager.

Continued

Table 2-15 *continued*

Problem	Possible Cause	Solution
No dial tone (continued)	The modem is not responding to commands from the computer keyboard.	Verify the modem and computer are connected: <ol style="list-style-type: none">1. Select Start → Programs → Accessories → HyperTerminal, then go to Terminal Mode.2. Type AT and press the Enter key. If the modem displays OK, the modem and computer are working together. If the modem displays ERROR, or does not respond, restart the computer and repeat step 1.3. Type ATDT and listen for dial tone.4. Type ATH0 to hang up.
Modem does not connect at highest speed.	Line conditions in your area or in the area you are calling may not support the highest connect speeds.	Have your telephone line checked by your local telephone service provider. Try dialing an alternate telephone number for the service you are using.
	Another device on your telephone line may be causing interference.	Hang up an extension telephone and disconnect any other devices that may be using the same telephone line, then redial.

Continued

Table 2-15 *continued*

Problem	Possible Cause	Solution
Modem does not connect at highest speed (continued).	The service or site called does not support 56K or supports an incompatible 56K implementation.	An internal modem supports K56flex. To find an Internet service provider (ISP) that supports K56flex, go to the Compaq Web site at www.compaq.com .
	There is noise on the telephone line.	The 56K protocol of an internal modem will fall back to lower speeds if the telephone line is too noisy for a high-speed connection. Try using another telephone line. Change the Hang-up Delay S Register: <ol style="list-style-type: none">1. Select Start → Programs → Accessories → HyperTerminal.2. Go to Command Mode, type <code>ATS10=150</code>, then press Enter. <p>NOTE: This command causes the modem to take longer to disconnect even if there is no noise on the line.</p>
	The telephone line does not support 56K implementation.	The 56K protocol requires that the telephone line contain no more than one analog-to-digital conversion. Try connecting from an alternate site.

Table 2-16
Solving PC Card Problems

Problem	Possible Cause	Solution
Computer does not beep when a PC Card is inserted.	PC Card is not inserted properly.	Try reinserting the card. Ensure that the PC Card is inserted in the correct orientation. Insert the card gently to prevent damage to the pins.
	Speakers are turned off or volume is turned down.	Adjust the volume control on the computer.
	PC Card or card driver is not PCMCIA compliant.	Check the list of PC Cards tested successfully in Compaq PC Card platforms.
Computer beeps only once when a PC Card is inserted.	The computer beeps once to indicate that a PC Card is recognized but not properly configured.	Before a new PC Card can be used, it may be necessary to perform an initial setup procedure. Follow the PC Card manufacturer's instructions for formatting a hard drive card or installing PC Card-specific drivers for a network card.
Network PC Card does not work.	Necessary drivers are not installed (turned on).	Refer to the instructions that came with the PC Card or contact the vendor for information on installing the correct drivers.
	PC Card is not fully inserted or is upside down.	Ensure the PC Card is inserted correctly.

Continued

Table 2-16 *continued*

Problem	Possible Cause	Solution
Network PC Card does not work (continued).	Network PC Card or driver is not PCMCIA compliant.	Check the list of PC Cards tested successfully in Compaq PC Card platforms.
Storage PC Card does not work.	SRAM and flash memory PC Cards require the memory card driver to be loaded.	Memory cards can only be accessed using DOS real mode drivers.
	You are trying to access the storage PC Card using the wrong drive letter.	If you are running Windows 95, change the drive letter assignment in Device Manager If you are running Windows NT 4.0, change the drive letter assignment through the Control Panel.
	The PC Card is not formatted.	For memory cards, run MCFORMAT in MS-DOS Mode to format the PC Card. For ATA cards, run ATAINIT, then run MCFORMAT in MS-DOS Mode to format the PC Card.
	The card is not supported.	Check the list of PC Cards tested successfully in Compaq PC Card platforms.
Storage cards, such as SRAM, do not work in the expansion base.	Use the storage card in the computer.	

Table 2-17
Solving Power Problems

Problem	Possible Cause	Solution
Computer will not turn on.	Battery is discharged and computer is not connected to a power source.	<ul style="list-style-type: none"> ■ Charge the battery pack. ■ Replace the battery pack. ■ Connect the computer to an external power source.
	Battery is discharged and cables to the external power source are unplugged.	Ensure that cables connecting the computer and the external power source are plugged in properly.
Computer turned off while it was left unattended.	Computer initiated because of a critical low battery condition.	<ul style="list-style-type: none"> ■ Charge the battery pack. ■ Replace the battery pack. ■ Connect the computer to an external power source.
	The computer initiated Hibernation after a user-defined timeout expired.	Turn on the computer.

Table 2-18
Solving Screen Problems

Problem	Possible Cause	Solution
Characters on computer display are dim.	Computer is in direct light.	Move the computer or adjust the screen.
	The brightness control is not set properly.	Adjust the brightness control by pressing the Fn+F10 hotkeys.
	You may have a screen saver or screen blanking utility installed.	Press any key to refresh the screen.
	Screen timeout was initiated.	Press any key to light the screen.
	System initiated Suspend after a user-defined timeout expired.	Press the suspend button to exit Suspend.
	Computer initiated a low battery Suspend or Hibernation.	<ul style="list-style-type: none">■ Replace the battery pack and exit Suspend or Hibernation.■ Connect the computer to an external power source and exit Suspend or Hibernation.

Continued

Table 2-18 *continued*

Problem	Possible Cause	Solution
Characters on computer display are dim (continued).	Power Management, which controls Suspend and Hibernation, is disabled and the battery pack has discharged.	<ul style="list-style-type: none">■ Replace the battery pack and turn on the computer.■ Connect the computer to an external power source and turn on the computer.
Computer screen is blank and external monitor displays information.	Display was switched to the external monitor.	Press Fn+F4 to display information on the computer screen; press Fn+F4 again to display information simultaneously on both screens.
	Display switch is stuck.	Tap the switch.
Fn+F4 hotkey combination does not switch between internal and external displays.	CRT or other display device is not connected properly.	Check your connections to ensure that an external device is connected properly.

Table 2-19
Solving USB Problems

Problem	Possible Cause	Solution
External device connected to a USB connector does not work.	The operating system limits external devices connected by USB to two tiers which can include no more than two hubs on the first tier and no more than one keyboard and one pointing device on the first or second tier.	Reduce the number of connected external USB devices to no more than two hubs on the first tier, and no more than one keyboard and one pointing device on the first or second tier.
External device connected to USB connector does not work during startup (before Windows 95 loads).	During startup, only two tiers are supported by the USB port. These tiers can include no more than two hubs on the first tier and no more than one keyboard and one pointing device on the first or second tier.	Use the external device only after Windows 95 or Windows 98 has loaded. Reduce the number of connected external USB devices to no more than two hubs on the first tier, and no more than one keyboard and one pointing device on the first or second tier.
External devices in lower tiers do not work.	An unpowered hub is connected to another unpowered hub.	Use only powered hubs. Make sure that all unpowered hubs are immediately preceded by powered hubs in the USB chain.

chapter 3

ILLUSTRATED PARTS CATALOG

This chapter provides an illustrated parts breakdown and a reference for spare part numbers and option part numbers for the Compaq Armada E500 and Armada V300 Series of Personal Computers.

3.1 Serial Number Location

When ordering parts or requesting information, provide the computer serial number and model number located on the bottom of the computer (Figure 3-1).

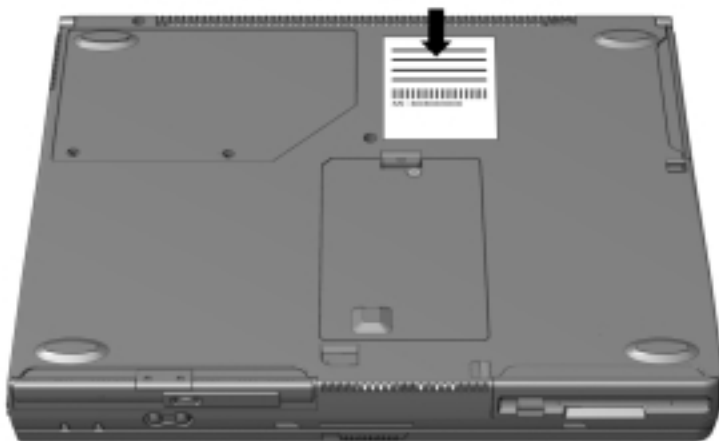

Figure 3-1. Serial Number Location

3.2 Computer System Major Components

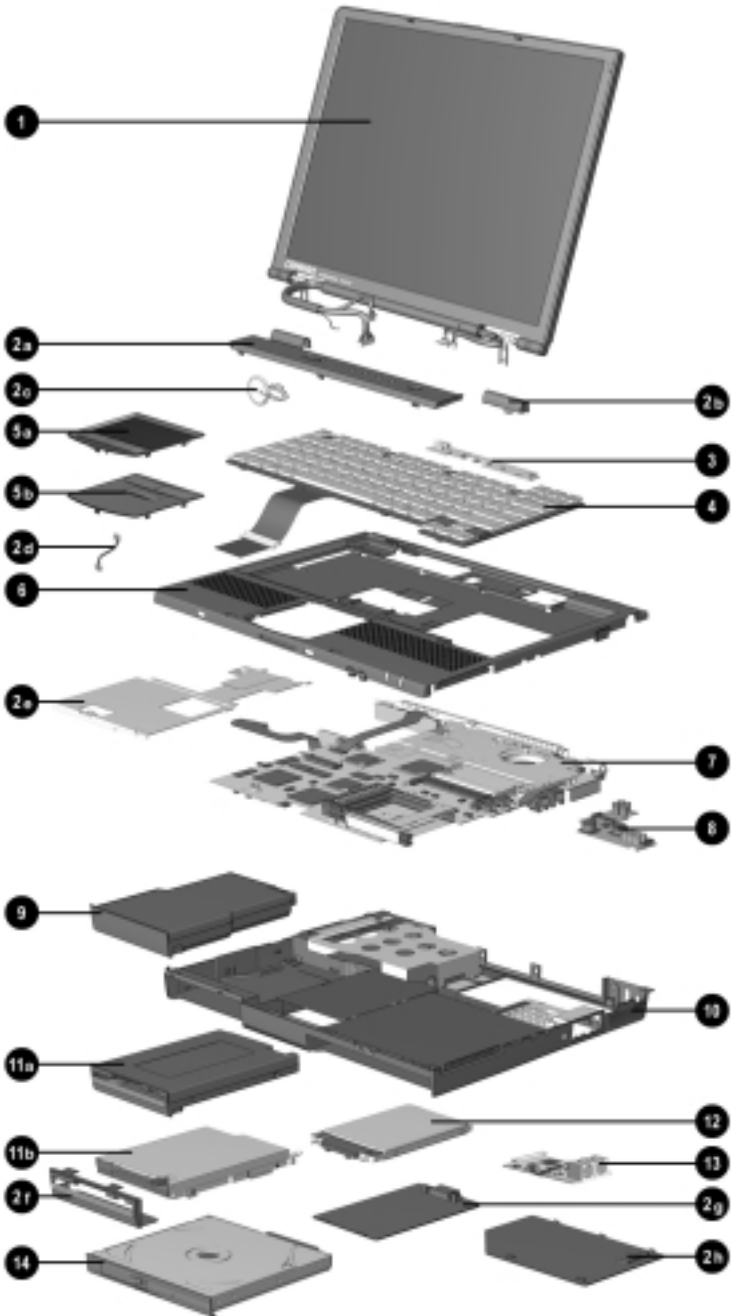

Figure 3-2. Computer System Major Components

Table 3-1
Spare Parts: Computer System Major Components

Item	Description	Spare Part Number
1	Display assembly 15.0-inch, TFT, XGA (use only with config. codes beginning with "DX" and "FFH")	190806-001
	14.1-inch, TFT, XGA use only with config. codes beginning with "CXX", "CZQ", "DC", "DN9", "DPB", "DVR", "FFD", and config. codes "DN81", "DN82", "DN84", "DN85", "DJD3", and "DJD4".	159532-001
	13.3-inch, TFT, XGA (Armada E500 only) use only with config. codes beginning with "DNN" and config. code "DN83".	167133-001
	13.3-inch, HPA, SVGA, (Armada V300 only) use only with config. codes beginning with "DVP".	177749-001
	12.1-inch, TFT, SVGA use only with config. codes beginning with "CXW", "DJC", "DNM", "DVQ", and config. codes "DJD1", "DJD2", "DVM1", and "DVM2"..	159531-001
	12.1-inch, HPA, SVGA, (Armada V300 only) use only with config. codes beginning with "CXV".	160536-001
	Miscellaneous Plastics Kit, includes:	159536-001
2a	Switch cover	not illustrated:
2b	Hinge cover	RJ-11 modem cover
2c	Real time clock (RTC) battery	RJ-45 LAN cover
2d	Touch button cable	Computer feet
2e	Front shield	Display screw covers
2f	Diskette drive bezel	TV out connector cover
2g	Hard drive cover	PC Card space saver
2h	Mini PCI slot cover	Diskette drive space saver CD-ROM drive space saver Infrared lens
3	LED board	159539-001
4	Keyboard with pointing stick (Armada E500 only)	154876-XXX
	Belgian -181	Latin American
	Brazilian -201	Spanish -161
	Danish -081	Norwegian -091
	French -051	Portuguese -131
	French Canadian -121	Spanish -071
	German -041	Swedish -101
	International -002	Swiss -111
	Italian -061	Taiwanese -AB1
	Japanese -291	U.K. English -031
	Korean -AD1	U.S. English -001

Continued

Table 3-1 *continued*

Item	Description	Spare Part Number
4	Keyboard without pointing stick	154877-XXX
	Arabic -171 Latin American	
	Belgian -181 Spanish	-161
	Brazilian -201 Norwegian	-091
	Danish -081 Portuguese	-131
	French -051 Spanish	-071
	French Canadian -121 Swedish	-101
	German -041 Swiss	-111
	International -002 Taiwanese	-AB1
	Italian -061 Turkish	-141
	Japanese -291 U.K. English	-031
	Korean -AD1 U.S. English	-001
5a	Touch button with TouchPad	135227-001
	Touch button 3 with TouchPad	188645-001
5b	Touch button without TouchPad (Armada E500 only)	159530-001
6	Top cover without TouchPad	159533-001
7	System board	
	Armada E500 only (all with 64 MB SDRAM)	
	Intel Pentium III 700-MHz processor (use only with config. codes beginning with "DX" and "FFH")	190804-001
	Intel Pentium III 650-MHz processor (use only with config. codes beginning with "DPB" and config. codes "FFD5" through "FFD8")	177751-001
	Intel Pentium III 600-MHz processor (use only with config. codes beginning with "DN9" and config. codes "FFD1" through "FFD4")	177750-001
	Intel Pentium III 500-MHz processor (use only with config. codes beginning with "DNM", "DNN", and "DVM", and config. code "DN83")	165102-001
	Intel Pentium III 450-MHz processor (use only with config. codes beginning with "CZQ" and config. codes "DN84" and "DN85")	165101-001
	Intel Pentium II 400-MHz processor (use only with config. codes beginning with "DC" and config. codes "DN81" and "DN82")	159528-001
	Intel Pentium II 366-MHz processor (use only with config. codes beginning with "DJC")	159527-001

Continued

Table 3-1 *continued*

Item	Description	Spare Part Number
7	System board (continued) Armada V300 only	
	Intel Celeron 500-MHz processor with 64 MB SDRAM (use only with config. codes beginning with "DVR")	177748-001
	Intel Celeron 466-MHz processor with 64 MB SDRAM (use only with config. codes beginning with "DVP")	177747-001
	Intel Celeron 466-MHz processor with 64 MB SDRAM (use only with config. codes beginning with "CXX" and "DVQ" and config. codes "DJD3" and "DJD4")	160535-001
	Intel Celeron 400-MHz processor with 64 MB SDRAM (use only with config. codes beginning with "CXW" and config. codes "DJD1" and "DJD2")	160534-001
	Intel Celeron 400-MHz processor with 32 MB SDRAM (use only with config. codes beginning with "CXV")	159540-001
	Fan (not illustrated; spared with system board and separately))	159535-001
8	Voltage converter board	152928-001
9	Li ion battery pack, 9 cell (standard on all Armada E500 models and some V300 models; also available as an option)	159524-001
	Li ion battery pack, 6 cell (standard on some Armada V300 models; also available as an option)	159529-001

Continued

Table 3-1 *continued*

Item	Description	Spare Part Number
10	CPU base enclosure	159534-001
11a	Removable diskette drive (Armada E500 only)	159538-001
11b	Fixed diskette drive (Armada V300 only)	160537-001
12	Removable hard drive	
	18.0 GB (Armada E500 only; available only as an option)	167528-001
	12.0 GB (Armada E500 only)	167527-001
	6.0 GB	159526-001
	4.3 GB	159525-001
	10.0 GB (available only as an option)	155351-001
13	Modem or combination modem/network interface (NIC) card	
	Type-II V.90 modem card	121895-001
	Type-II combination modem/NIC card	153207-001
14	MultiBay device (availability varies by computer model)	
	24X CD-ROM drive	315082-002
	8X DVD-ROM drive	173949-001
	4X DVD-ROM drive	102266-001
	The following are available only as options:	
	Li ion MultiBay battery pack, 6 cell	100680-001
	LS-120 SuperDisk drive	327456-003
	Hard Drive MultiBay Adapter	153100-001

3.3 Miscellaneous Plastics Kit Components

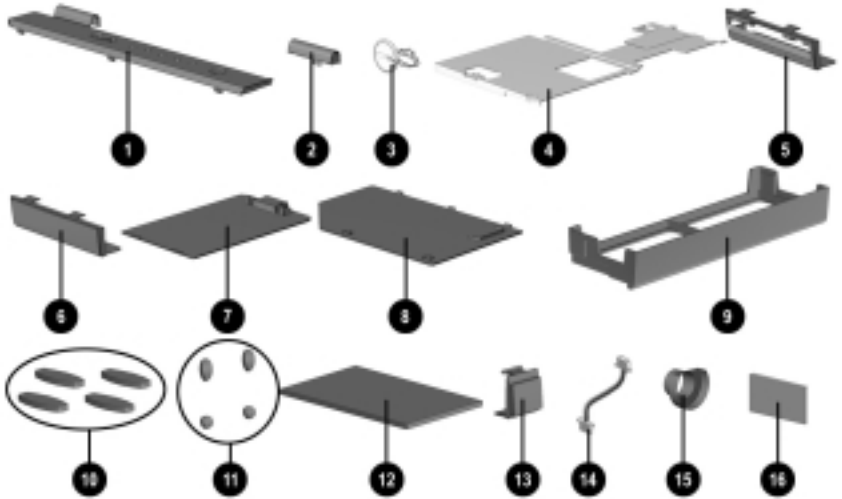

Figure 3-3. Miscellaneous Plastics Kit Components

Table 3-2
Miscellaneous Plastics Kit Components
Spare Part Number 159536-001

Item	Description
1	Switch cover
2	Hinge cover
3	Real time clock (RTC) battery
4	Front shield
5	Diskette drive bezel
6	Diskette drive space saver
7	Hard drive cover
8	Mini PCI slot cover
9	CD-ROM drive space saver
10	Computer feet (4)
11	Display screw covers (4)
12	PC Card space saver (2)
13	RJ-11 modem cover & RJ-45 LAN cover (2)
14	Touch button cable
15	TV out connector cover
16	Infrared lens

3.4 Mass Storage Devices

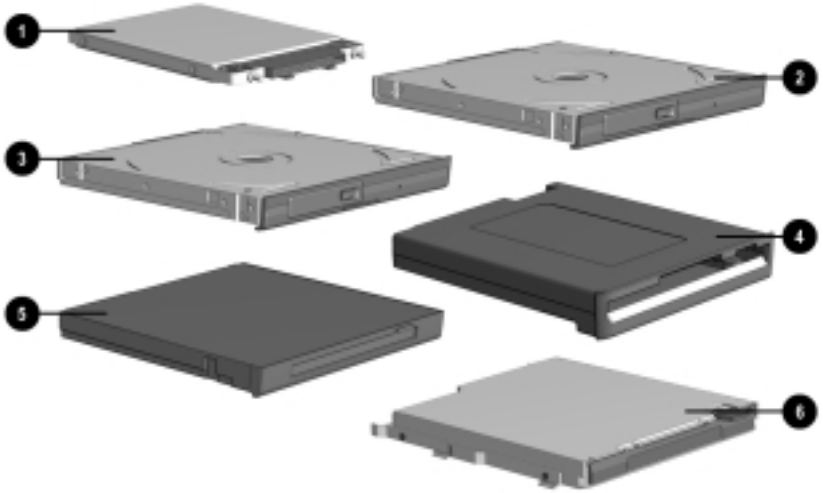

Figure 3-4. Mass Storage Devices

**Table 3-3
Spare Parts: Mass Storage Devices**

Item	Description	Spare Part Number
1	Hard drive 18.0 GB (Armada E500 only; available only as an option)	167528-001
	12.0 GB (Armada E500 only)	167527-001
	6.0 GB (Armada E500 only)	159526-001
	4.3 GB	159525-001
	10.0 GB (available only as an option)	155351-001
2	24X CD-ROM drive	315082-002
3	8X DVD-ROM drive	173949-001
	4X DVD-ROM drive	102266-001
4	Removable diskette drive, 1.44-megabyte, 3.5-inch (standard on Armada E500 only)	159538-001
5	LS-120 SuperDisk drive (available only as an option)	327456-003
6	Fixed diskette drive (Armada V300 only)	160537-001

3.5 Miscellaneous

Table 3-4
Spare Parts: Miscellaneous (not illustrated)

Description	Spare Part Number
Power cord, black, 6 feet	246959-XXX
Australian -011	Korean -AD1
Danish -081	Swiss -AG1
International -021	U.K. English -031
Italian -061	U.S. English -001
Japanese -291	
RJ11 modem cable	165224-001
RJ45 modem cable	191230-001
Hard drive adapter	155352-001
Battery charger	153991-001
AC Adapter, 50 W	163444-001 or 101898-001*
* When ordering an AC Adapter, use the spare part number on the part number label of the adapter being replaced.	
Miscellaneous Screw Kit	159537-001
Memory expansion board	
256 MB	167136-001
128 MB	135244-001
64 MB	135243-001
32 MB	135242-001
Armada E500 and Armada V300 <i>Maintenance & Service Guide</i>	162812-001
Return Kit	159541-001

chapter 4

REMOVAL AND REPLACEMENT PRELIMINARIES

This chapter provides essential information for proper and safe removal and replacement service.

4.1 Tools Required

You will need the following tools to complete the removal and replacement procedures:

- Magnetic screwdriver
- Torx T-8 screwdriver
- Phillips screwdriver (for screw securing diskette drive bezel to base assembly on Armada V300 only)
- 7-mm hex socket (for bushing guides)
- Tool kit (includes connector removal tool, loopback plugs, and case utility tool)

4.2 Service Considerations

Listed below are some of the considerations that you should keep in mind during disassembly and assembly procedures.

IMPORTANT: As you remove each subassembly from the computer, place it (and all accompanying screws) away from the work area to prevent damage.

Plastic Parts

Using excessive force during disassembly and reassembly can damage plastic parts. Use care when handling the plastic parts. Apply pressure only at the points designated in the maintenance instructions.

Cables and Connectors

Cables must be handled with extreme care to avoid damage. Apply only the tension required to unseat or seat the cables during removal and insertion. Handle cables by the connector whenever possible. In all cases, avoid bending, twisting, or tearing cables. Ensure that cables are routed in such a way that they cannot be caught or snagged by parts being removed or replaced. Handle flex cables with extreme care; they tear easily.



CAUTION: When servicing the computer, ensure that cables are placed in their proper location during the reassembly process. Improper cable placement can damage the computer.

4.3 Preventing Damage to Removable Drives

Removable drives are fragile components that must be handled with care. To prevent damage to the computer, damage to a removable drive, or loss of information, observe these precautions:

- Before removing or inserting a hard drive, shut down the computer. If you are unsure whether the computer is off or in Hibernation, turn the computer on, then shut it down.
- Before removing a diskette drive or CD-ROM drive, ensure that a diskette or disc is *not* in the drive. Ensure that the CD-ROM tray is closed.
- Before handling a drive, ensure that you are discharged of static electricity. While handling a drive, avoid touching the connector.
- Handle drives on surfaces that have at least one inch of shock-proof foam.
- Avoid dropping drives from any height onto any surface.
- After removing a hard drive, place it into a static-proof bag.
- After removing a CD-ROM drive or a diskette drive, place it into a static-proof bag.
- Do not use excessive force when inserting a drive into a drive bay.
- After inserting a hard drive into the hard drive bay, always reinsert either the original hard drive security plate or the tamper-resistant security plate to prevent the hard drive from accidentally disconnecting.

- Avoid exposing a hard drive to products that have magnetic fields such as monitors or speakers.
- Avoid exposing a drive to temperature extremes or to liquids.
- If a drive must be mailed, do the following: place the drive into a bubble pack mailer or other suitable form of protective packaging; label the package “Fragile: Handle With Care.”

4.4 Preventing Electrostatic Damage

Many electronic components are sensitive to electrostatic discharge (ESD). Circuitry design and structure determine the degree of sensitivity. Networks built into many integrated circuits provide some protection, but in many cases the discharge contains enough power to alter device parameters or melt silicon junctions.

A sudden discharge of static electricity from a finger or other conductor can destroy static-sensitive devices or microcircuitry. Often the spark is neither felt nor heard, but damage occurs. An electronic device exposed to electrostatic discharge may not be affected at all and can work perfectly throughout a normal cycle. It may function normally for a while, then degrade in the internal layers, reducing its life expectancy.

4.5 Packaging and Transporting Precautions

Use the following grounding precautions when packaging and transporting equipment:

- To avoid hand contact, transport products in static-safe containers such as tubes, bags, or boxes.
- Protect all electrostatic-sensitive parts and assemblies with conductive or approved containers or packaging.
- Keep electrostatic-sensitive parts in their containers until they arrive at static-free workstations.
- Place items on a grounded surface before removing them from their container.
- Always be properly grounded when touching a sensitive component or assembly.

- Place reusable electrostatic-sensitive parts from assemblies in protective packaging or non-conductive foam.
- Use transporters and conveyers made of antistatic belts and roller bushings. Ensure that mechanized equipment used for moving materials is wired to ground, and that proper materials were selected to avoid static charging. When grounding is not possible, use an ionizer to dissipate electric charges.

4.6 Workstation Precautions

Use the following grounding precautions at workstations:

- Cover the workstation with approved static-dissipative material (refer to Table 4-2 later in this chapter).
- Use a wrist strap connected to a properly grounded work surface and use properly grounded tools and equipment.
- Use field service tools, such as cutters, screwdrivers, and vacuums that are conductive.
- When using fixtures that must directly contact dissipative surfaces, use fixtures made of static-safe materials only.
- Keep work area free of nonconductive materials such as ordinary plastic assembly aids and Styrofoam.
- Handle electrostatic-sensitive components, parts, and assemblies by the case or PCM laminate. Handle them only at static-free workstations.
- Avoid contact with pins, leads, or circuitry.
- Turn off power and input signals before inserting or removing connectors or test equipment.

4.7 Grounding Equipment and Methods

Grounding equipment must include either a wrist strap or a foot strap at a grounded workstation.

- When seated, wear a wrist strap connected to a grounded system. Wrist straps are flexible straps with a minimum of one megaohm $\pm 10\%$ resistance in the ground cords. To provide proper ground, wear a strap snug against the skin at all times. On grounded mats with banana-plug connectors, connect a wrist strap with alligator clips.
- When standing, use foot straps and a grounded floor mat. Foot straps (heel, toe, or boot straps) can be used at standing workstations and are compatible with most types of shoes or boots. On conductive floors or dissipative floor mats, use them on both feet with a minimum of one-megohm resistance between the operator and ground. To be effective, the conductive strips must be worn in contact with the skin.
- Other grounding equipment recommended for use in preventing electrostatic damage include:
 - Antistatic tape
 - Antistatic smocks, aprons, or sleeve protectors
 - Conductive bins and other assembly or soldering aids
 - Non-conductive foam
 - Conductive tabletop workstations with ground cord of one-megohm resistance
 - Static-dissipative table or floor mats with hard tie to ground
 - Field service kits
 - Static awareness labels
 - Material-handling packages
 - Non-conductive plastic bags, tubes, or boxes
 - Metal tote boxes
 - Electrostatic Voltage Levels and Protective Materials

Table 4-1 shows how humidity affects the electrostatic voltage levels generated by different activities.

Table 4-1
Typical Electrostatic Voltage Levels

Event	Relative Humidity		
	10%	40%	55%
Walking across carpet	35,000 V	15,000 V	7,500 V
Walking across vinyl floor	12,000 V	5,000 V	3,000 V
Motions of bench worker	6,000 V	800 V	400 V
Removing DIPS from plastic tube	2,000 V	700 V	400 V
Removing DIPS from vinyl tray	11,500 V	4,000 V	2,000 V
Removing DIPS from Styrofoam	14,500 V	5,000 V	3,500 V
Removing bubble pack from PCB	26,500 V	20,000 V	7,000 V
Packing PCBs in foam-lined box	21,000 V	11,000 V	5,000 V

NOTE: A product can be degraded 700 volts.

Table 4-2 lists the shielding protection provided by antistatic bags and floor mats.

Table 4-2
Static-Shielding Materials

Material	Use	Voltage Protection Level
Antistatic plastic	Bags	1,500 V
Carbon-loaded plastic	Floor mats	7,500 V
Metallized laminate	Floor mats	15,000 V

chapter 5

REMOVAL AND REPLACEMENT PROCEDURES

This chapter provides removal and replacement procedures for the Compaq Armada E500 and Armada V300 Series of Personal Computers.

5.1 Serial Number

Report the computer serial number to Compaq when requesting information or ordering spare parts. The serial number is located on the bottom of the computer (Figure 5-1).

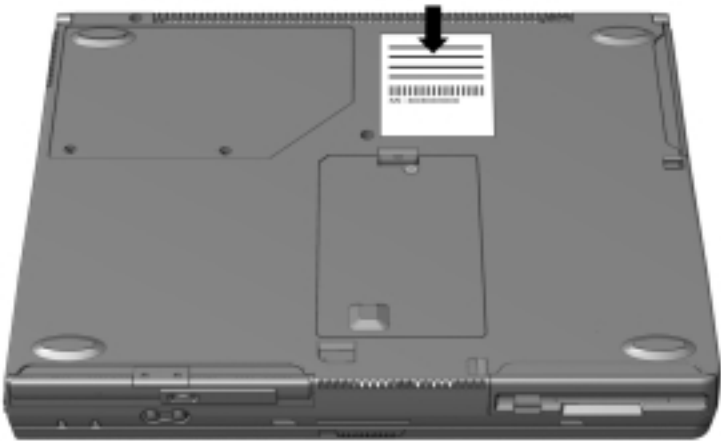

Figure 5-1. *Serial Number Location*

5.2 Disassembly Reference Chart

Use the chart below to determine the section number to be referenced when removing components from the computer.

Table 5-1 Disassembly Sequence Chart	
5.3 Preparing the Computer for Disassembly	
5.4 Computer Feet	
5.5 Mini PCI Slot	
	Removing the Mini PCI Slot Cover
	Installing a Modem or Modem/Network Interface Card
5.6 Touch Button	
5.7 Keyboard	
5.8 Memory	
	Removing a Memory Expansion Board
	Installing a Memory Expansion Board
5.9 Display Assembly	
5.10 Real Time Clock (RTC) Battery	
5.11 LED Board	
5.12 Top Cover	
5.13 Front Shield	
5.14 Diskette Drive (Armada V300 only)	
5.15 System Board	
5.16 Voltage Converter Board	
5.17 Fan	

5.3 Preparing the Computer for Disassembly

Perform the following steps before disassembling the computer. Consult the computer reference guide, available as an electronic book on the QuickRestore CD-ROM, for instructions on the steps below.

1. Undock the computer from the docking base.
2. Disconnect the AC Adapter and external devices.
3. Remove any battery packs inserted into the battery bay, DualBay (Armada E500 only), or MultiBay.
4. If installed, remove the diskette drive from the DualBay (Armada E500 only).
5. Remove the hard drive from the hard drive bay.
6. Remove any devices installed in the MultiBay.

5.4 Computer Feet

The base feet are oblong, adhesive-backed rubber pads. The base feet are included in the Miscellaneous Plastic Kit.

Computer Feet Spare Part Number Information

Miscellaneous Plastics Kit, includes:	159536-001
Switch cover	RJ-11 modem cover
Hinge cover	RJ-45 LAN cover
Real time clock (RTC) battery	Computer feet
Touch button cable	Display screw covers
Front shield	TV out connector cover
Diskette drive bezel	PC Card space saver
Hard drive cover	Diskette drive space saver
Mini PCI slot cover	CD-ROM drive space saver
	Infrared lens

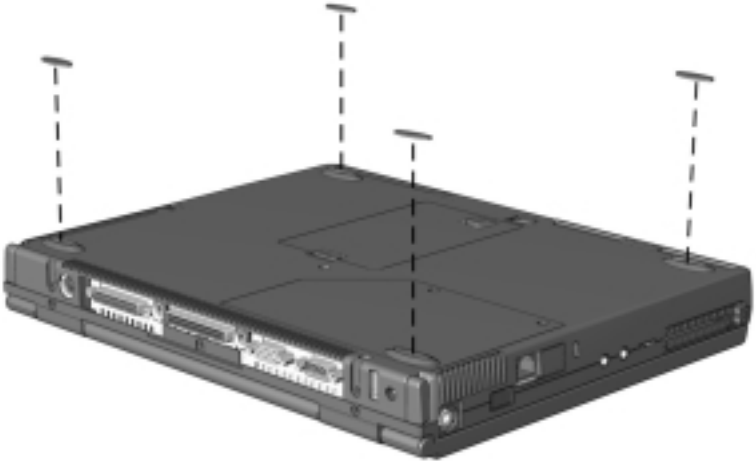

Figure 5-2. *Installing the Computer Feet*

5.5 Mini PCI Slot

Modem and Modem/Network Interface Card Spare Part Number Information

Mini PCI V. 90 modem card	121895-001
Mini PCI V. 90 modem/Network Interface Card	153207-001

Removing the Mini PCI Slot Cover

1. Prepare the computer for disassembly (Section 5.3).
2. Turn the computer bottom side up with the front facing forward.
3. Remove the two screws ❶ that secure the mini PCI slot cover to the base enclosure (Figure 5-3).
4. Lift up the front edge of the mini PCI slot cover and swing the cover back ❷.

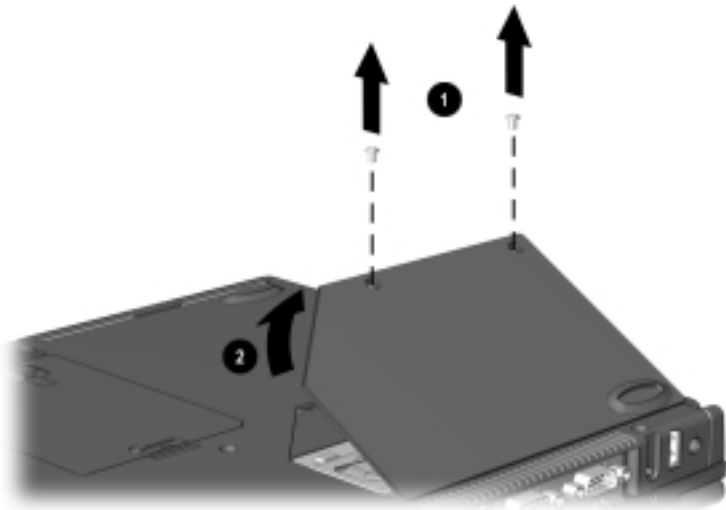

Figure 5-3. Removing the Mini PCI Slot Cover

5. Remove the mini PCI slot cover.

Reverse the removal procedure described above to replace the mini PCI slot cover.

Installing a Modem or Modem/Network Interface Card

1. Remove the mini PCI slot cover.
2. Remove the two screws ❶ that secure the modem or modem/NIC to the system board (Figure 5-4).
3. Make sure the appropriate RJ11/RJ45 cover(s) are removed from the base enclosure.
4. Install the card into the mini PCI slot, making sure to seat the card connector on the system board ❷.

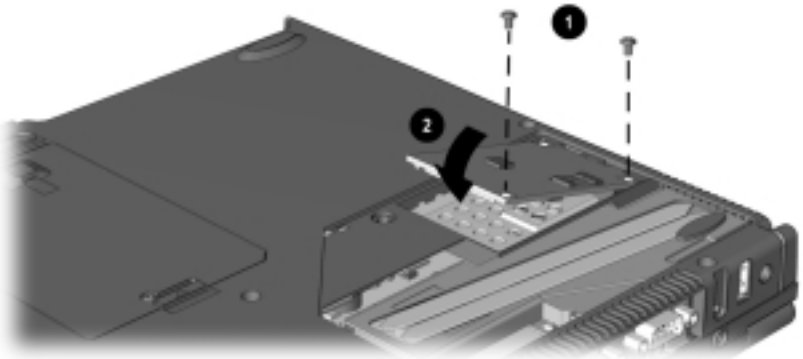

Figure 5-4. *Installing a Modem or Modem/Network Interface Card*

Reverse the installation procedure described above to remove a modem or modem/Network Interface Card.

5.6 Touch Button

Touch Button Spare Part Number Information

Touch Button without TouchPad (Armada E500 only)	159530-001
Touch 3 Button with TouchPad	188645-001
Touch Button with TouchPad	135227-001

Removing the Touch Button

1. Prepare the computer for disassembly (Section 5.3).
2. Position the computer with the front facing forward.
3. Open the computer.
4. Use a flat blade screwdriver to pry the upper right corner of the touch button away from the top cover ❶ (Figure 5-5).
5. Lift the right side of the touch button away from the top cover ❷ and swing the touch button up and to the left ❸.
6. Disconnect the touch button cable from the system board ❹.
7. Remove the touch button.



Figure 5-5. Removing the Touch Button

8. Disconnect the touch button cable from the touch button (Figure 5-6).

NOTE: The touch button cable is included in the Miscellaneous Plastic Kit.

Touch Button Cable Spare Part Number Information

Miscellaneous Plastics Kit, includes:	159536-001
Switch cover	RJ-11 modem cover
Hinge cover	RJ-45 LAN cover
Real time clock (RTC) battery	Computer feet
Touch button cable	Display screw covers
Front shield	TV out connector cover
Diskette drive bezel	PC Card space saver
Hard drive cover	Diskette drive space saver
Mini PCI slot cover	CD-ROM drive space saver
	Infrared lens



Figure 5-6. *Disconnecting the Touch Button Cable*

Reverse the removal procedure described above to replace the touch button.

5.7 Keyboard

Keyboard with Pointing Stick Spare Part Number Information (Armada E500 only)

Keyboard with Pointing Stick				154876-XXX	
Brazilian	-201	Italian	-061	Spanish	-071
Belgian	-181	International	-002	Swedish	-101
Danish	-081	Japanese	-291	Swiss	-111
French	-051	Korean	-AD1	Taiwanese	-AB1
French		Latin American		U.K. English	-031
Canadian	-121	Spanish	-161	U.S. English/ Canadian	-001
German	-041	Norwegian	-091		
		Portuguese	-131		

Keyboard without Pointing Stick Spare Part Number Information

Keyboard without Pointing Stick				154877-XXX	
Arabic	-171	Italian	-061	Spanish	-071
Brazilian	-201	International	-002	Swedish	-101
Belgian	-181	Japanese	-291	Swiss	-111
Danish	-081	Korean	-AD1	Taiwanese	-AB1
French	-051	Latin American		Turkish	-141
French		Spanish	-161	U.K. English	-031
Canadian	-121	Norwegian	-091	U.S. English/ Canadian	-001
German	-041	Portuguese	-131		

Removing the Keyboard

1. Prepare the computer for disassembly (Section 5.3).
2. Turn the computer bottom side up with the front facing forward.
3. Remove the screw that secures the keyboard (Figure 5-7).

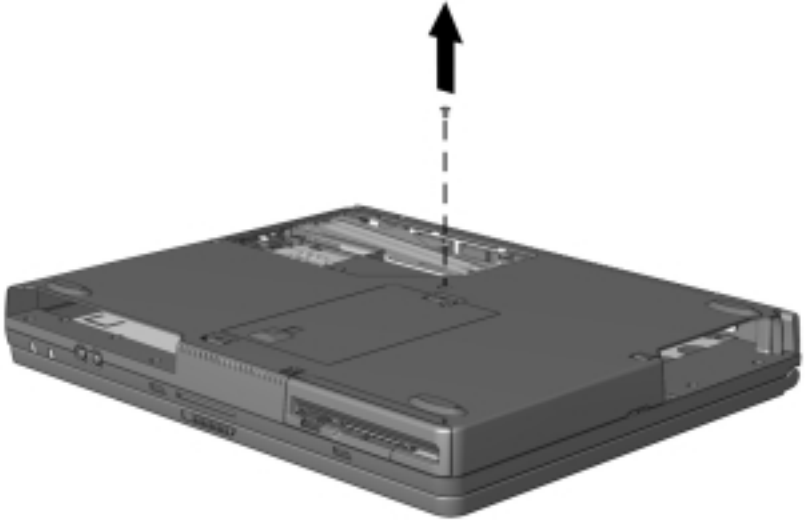

Figure 5-7. Removing the Keyboard Screw

4. Turn the computer right side up with the front facing forward.
5. Open the computer.
6. Slide the four latches ❶ located along the top of the keyboard forward.
7. Swing the back edge of the keyboard ❷ up and forward (Figure 5-8).



Figure 5-8. Releasing the Keyboard

8. Release the ZIF (Zero Insertion Force) connector that connects the keyboard cable ❶ (Figure 5-9).
9. Disconnect the keyboard cable from the system board ❷.
10. **(Armada E500 only)** Release the ZIF connector that connects the pointing stick cable ❸.
11. **(Armada E500 only)** Disconnect the pointing device cable from the system board ❹.

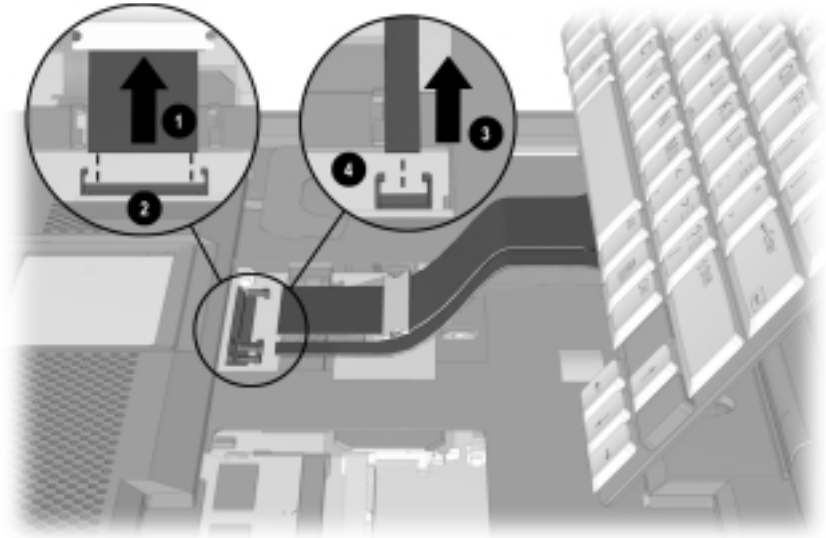

Figure 5-9. *Releasing and Disconnecting the Keyboard Cables*

12. Remove the keyboard.

Reverse the removal procedure described above to replace the keyboard.

5.8 Memory

The Compaq Armada E500 and Armada V300 Series feature two memory expansion slots, located under the keyboard. Depending on the computer model, one slot will contain a 64- or 32-MB memory expansion board.



WARNING: Failure to unplug the power cord and remove the battery pack before installing a memory expansion board can damage the equipment and expose you to the risk of electrical shock.



CAUTION: Electrostatic discharge (ESD) can damage electronic components. Before beginning this procedure, ensure that you are properly grounded. For more information, refer to the section on “Preventing Electrostatic Damage” in Chapter 4.

Memory Expansion Board Spare Part Number Information

Memory expansion board

256 MB	167136-001
128 MB	135244-001
64 MB	135243-001
32 MB	135242-001

Removing a Memory Expansion Board

1. Prepare the computer for disassembly (Section 5.3).
2. Remove the keyboard (Section 5.7).
3. Spread the retaining tabs apart ❶. The memory expansion board tilts upward (Figure 5-10).
4. Lift the edge of the memory expansion board and slide it gently out of the memory expansion slot at a 45-degree angle ❷.
5. Place the memory expansion board in an electrostatic-safe container.

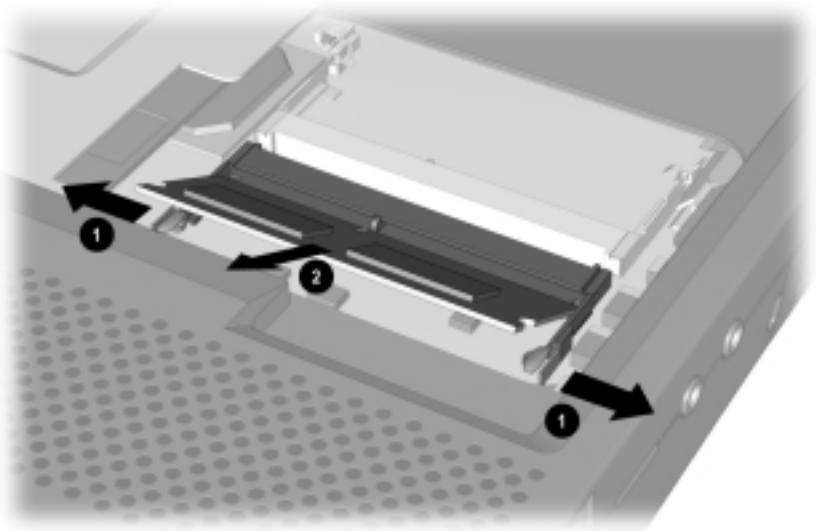

Figure 5-10. Removing a Memory Expansion Board

Installing a Memory Expansion Board

All memory expansion boards are asymmetrically keyed (notched) to ensure correct positioning. Memory expansion boards can be used in either memory expansion slot.

1. Insert the memory expansion board into an empty memory expansion slot at a 45-degree angle ❶ (Figure 5-11).
2. Push the memory expansion board down ❷ until the board is seated in the plastic retention clips.
3. Run Computer Setup (refer to Section 2.5).

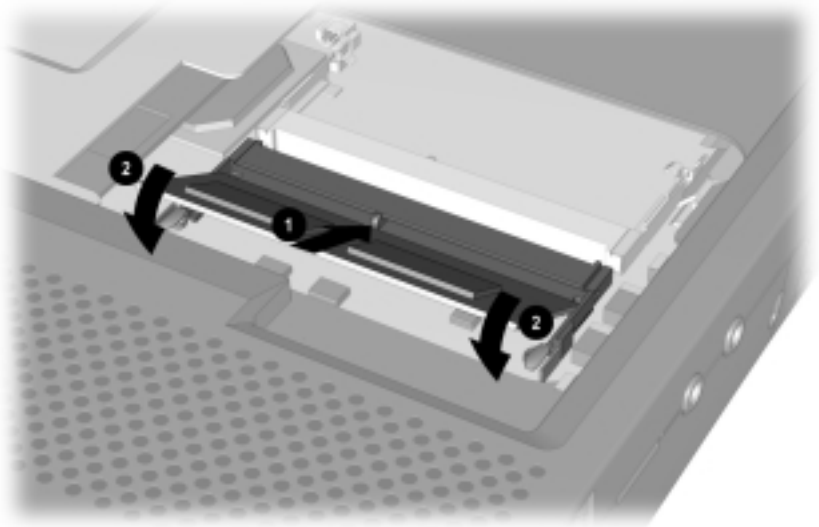

Figure 5-11. *Installing a Memory Expansion Board*

5.9 Display Assembly

Display Assembly Spare Part Number Information	
Display assembly 15.0-inch, TFT, XGA (use only with config. codes beginning with "DX" and "FFH")	190806-001
Display assembly 14.1-inch, TFT, XGA use only with config. codes beginning with "CXX", "CZQ", "DC", "DN9", "DPB", "DVR", "FFD", and config. codes "DN81", "DN82", "DN84", "DN85", "DJD3", and "DJD4".	159532-001
13.3-inch, TFT, XGA (Armada E500 only) use only with config. codes beginning with "DNN" and config. code "DN83".	167133-001
13.3-inch, HPA, SVGA, (Armada V300 only) use only with config. codes beginning with "DVP".	177749-001
12.1-inch, TFT, SVGA use only with config. codes beginning with "CXW", "DJC", "DNM", "DVQ", and config. codes "DJD1", "DJD2", "DVM1", and "DVM2"..	159531-001
12.1-inch, HPA, SVGA, (Armada V300 only) use only with config. codes beginning with "CXV".	160536-001

Removing the Display

1. Prepare the computer for disassembly (Section 5.3).
2. Position the computer so the rear panel faces forward (Figure 5-12).
3. Remove the screws that secure the hinge cover ❶ and switch cover ❷.
4. Lift the hinge cover up ❸ and remove it.



Figure 5-12. Removing the Switch and Hinge Cover Screws

5. Open the computer as far as it will open.
6. Push the back of the switch cover up ❶ (Figure 5-13).
7. Position the computer so the front faces forward.
8. Swing the switch cover up and forward ❷.
9. Remove the switch cover.

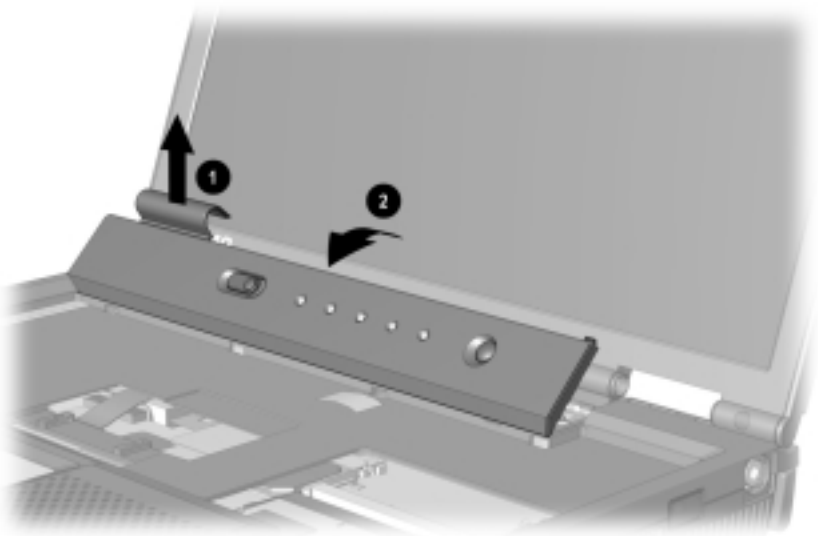

Figure 5-13. *Removing the Switch Cover*

NOTE: The hinge and switch covers are spared in the Miscellaneous Plastics Kit.

Switch and Hinge Cover Spare Part Number Information

Miscellaneous Plastics Kit, includes:	159536-001
Switch cover	RJ-11 modem cover
Hinge cover	RJ-45 LAN cover
Real time clock (RTC) battery	Computer feet
Touch button cable	Display screw covers
Front shield	TV out connector cover
Diskette drive bezel	PC Card space saver
Hard drive cover	Diskette drive space saver
Mini PCI slot cover	CD-ROM drive space saver
	Infrared lens

10. Remove the screws ❶ that secure the display ground cables (Figure 5-14).
11. Disconnect the display panel ❷, microphone ❸ and display inverter cables ❹ from the system board.

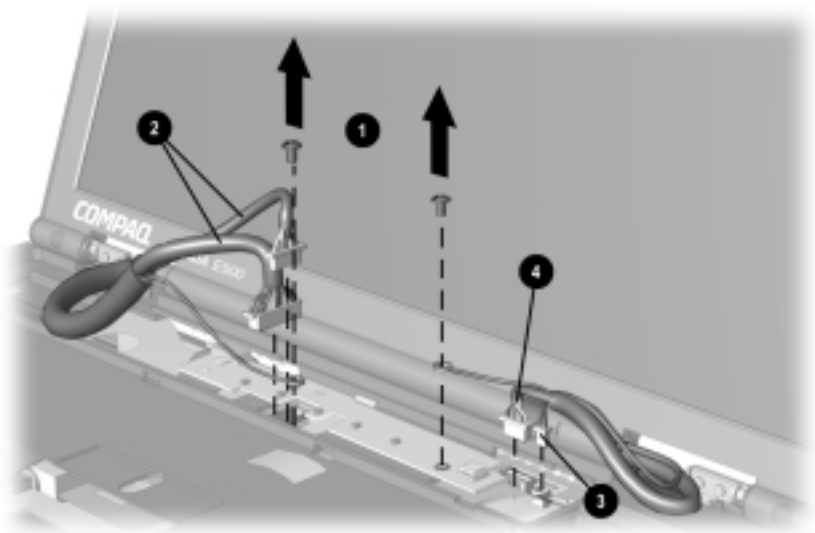

Figure 5-14. Disconnecting the Display Assembly Cables

12. Position the computer so the rear panel faces forward.
13. Remove the two screws that secure the display assembly to the base enclosure ❶ (Figure 5-15).

NOTE: When these screws are removed, the display assembly is unsupported. Make sure to provide support for the display assembly when removing these screws.

14. Remove the display assembly ❷.

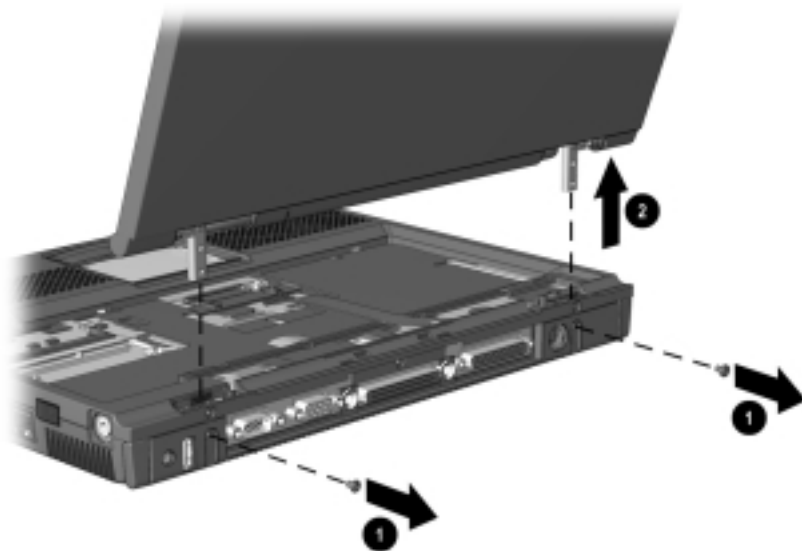

Figure 5-15. Removing the Display Assembly

Reverse the removal procedure described above to replace the display assembly.

5.10 Real Time Clock (RTC) Battery

The RTC battery is spared in the Miscellaneous Plastics Kit.

RTC Battery Spare Part Number Information

Miscellaneous Plastics Kit, includes:	159536-001
Switch cover	RJ-11 modem cover
Hinge cover	RJ-45 LAN cover
Real time clock (RTC) battery	Computer feet
Touch button cable	Display screw covers
Front shield	TV out connector cover
Diskette drive bezel	PC Card space saver
Hard drive cover	Diskette drive space saver
Mini PCI slot cover	CD-ROM drive space saver
	Infrared lens

Removing the RTC Battery

1. Prepare the computer for disassembly (Section 5.3).
2. Remove the switch cover (Section 5.9).
3. Disconnect the RTC battery cable from the LED board ❶ (Figure 5-16).
4. Remove the RTC battery from the base enclosure ❷.

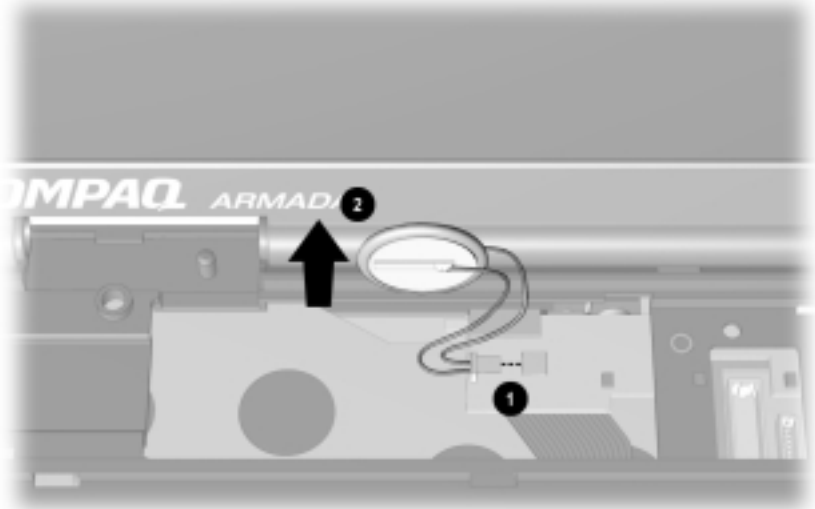

Figure 5-16. Removing the Real Time Clock Battery

The battery fits into two slots molded into the base enclosure. Make sure to reinsert the RTC battery into these slots when replacing the battery.

5.11 LED Board

LED Board Spare Part Number Information

LED Board

159539-001

Removing the LED Board

1. Prepare the computer for disassembly (Section 5.3)
2. Remove the switch cover (Section 5.9).
3. Disconnect the display ground cables (Section 5.9) and RTC battery cable (Section 5.10) from the LED board.
4. Remove the screw ❶ that secures the LED board to the system board (Figure 5-17).
5. Lift up on the right side of the LED board ❷ to disconnect it from the system board.

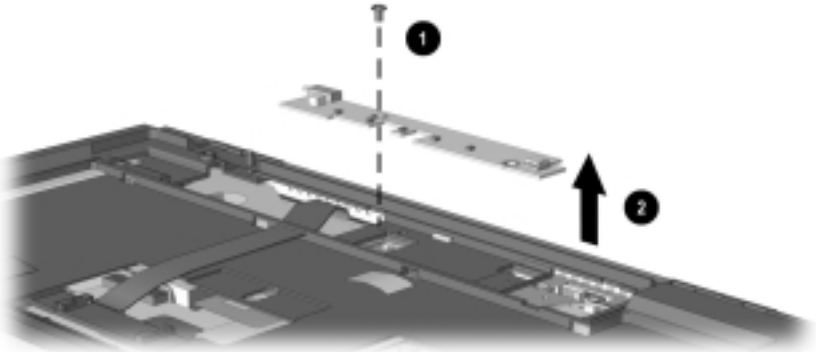

Figure 5-17. Removing the LED Board

6. Remove the LED board.

Reverse the removal procedure described above to replace the LED board.

5.12 Top Cover

Top Cover Spare Part Number Information

Top Cover without TouchPad

159533-001

Removing the Top Cover

1. Prepare the computer for disassembly (Section 5.3) and, in the order below, remove the following components:
 - touch button (Section 5.6)
 - keyboard (Section 5.7)
 - display assembly (Section 5.9)
 - LED board (Section 5.11).
2. Turn the computer bottom side up with the front facing forward.
3. (**Armada V300 only**) Remove the screw ❶ that secures the diskette drive bezel to the base enclosure (Figure 5-18).
4. (**Armada V300 only**) Slide the diskette drive release latch to the left ❷.
5. (**Armada V300 only**) Remove the diskette drive bezel from the base enclosure ❸.

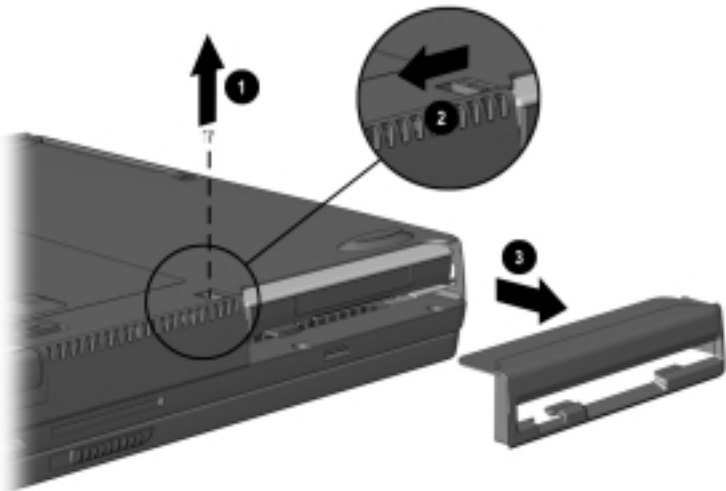

Figure 5-18. Removing the Diskette Drive Bezel

NOTE: The diskette drive bezel is spared in the Miscellaneous Plastic Kit.

Diskette Drive Bezel Spare Part Number Information

Miscellaneous Plastics Kit, includes:	159536-001
Switch cover	RJ-11 modem cover
Hinge cover	RJ-45 LAN cover
Real time clock (RTC) battery	Computer feet
Touch button cable	Display screw covers
Front shield	TV out connector cover
Diskette drive bezel	PC Card space saver
Hard drive cover	Diskette drive space saver
Mini PCI slot cover	CD-ROM drive space saver
	Infrared lens

6. Remove the eight screws from the bottom of the computer that secure the top cover to the base enclosure (Figure 5-19).

NOTE: There are only seven screws to be removed in this step on the Armada V300 computer. The eighth screw was removed in Step 3 when removing the diskette drive bezel.

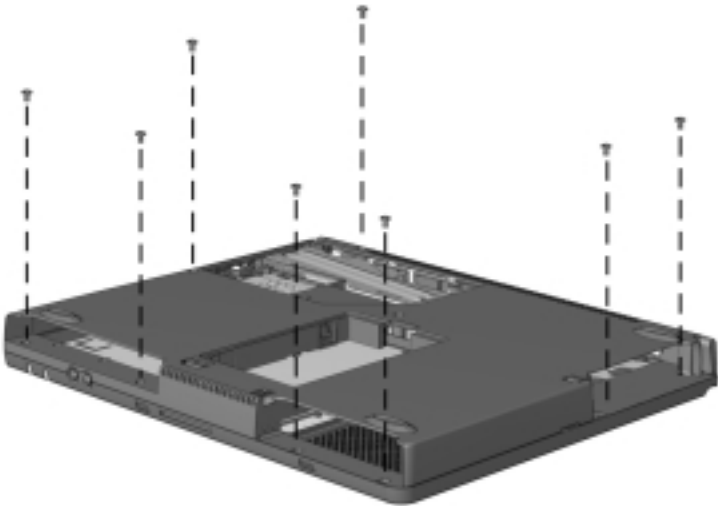

Figure 5-19. Removing the Top Cover Screws

7. Turn the computer top side up with the rear panel facing forward.
8. Remove the screw ❶ that secures the top cover to the base enclosure (Figure 5-20).
9. Disconnect the left ❷ and right ❸ speaker cables from the system board.

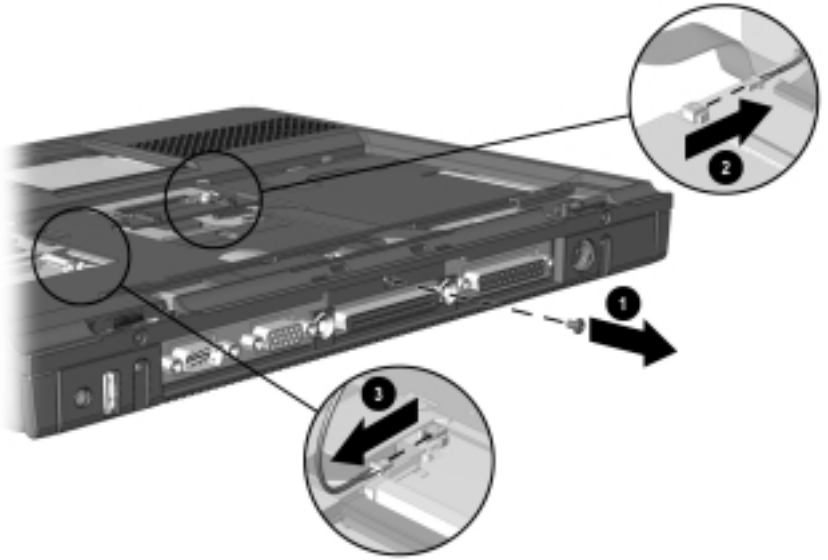

Figure 5-20. Removing the Top Cover Rear Panel Screw and Disconnecting the Speaker Cables

10. Lift the back edge of the top cover ❶ and swing it forward ❷ (Figure 5-21).

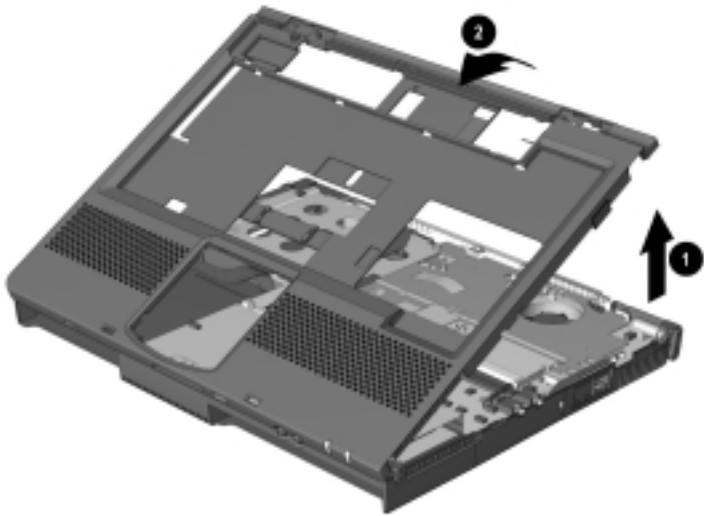

Figure 5-21. *Removing the Top Cover*

11. Remove the top cover.

Reverse the removal procedure described above to replace the top cover.

5.13 Front Shield

The front shield is spared in the Miscellaneous Plastics Kit.

Front Shield Spare Part Number Information	
Miscellaneous Plastics Kit, includes:	159536-001
Switch cover	RJ-11 modem cover
Hinge cover	RJ-45 LAN cover
Real time clock (RTC) battery	Computer feet
Touch button cable	Display screw covers
Front shield	TV out connector cover
Diskette drive bezel	PC Card space saver
Hard drive cover	Diskette drive space saver
Mini PCI slot cover	CD-ROM drive space saver
	Infrared lens

Removing the Front Shield

1. Prepare the computer for disassembly (Section 5.3) and, in the order below, remove the following components:
 - touch button (Section 5.6)
 - keyboard (Section 5.7)
 - display assembly (Section 5.9)
 - LED board (Section 5.11)
 - top cover (Section 5.12).
2. Position the computer so the rear panel faces forward.

3. Remove the screw ❶ that secures the front shield to base enclosure (Figure 5-22).
4. Lift the front edge of the front shield up and swing it toward the back of the computer ❷.

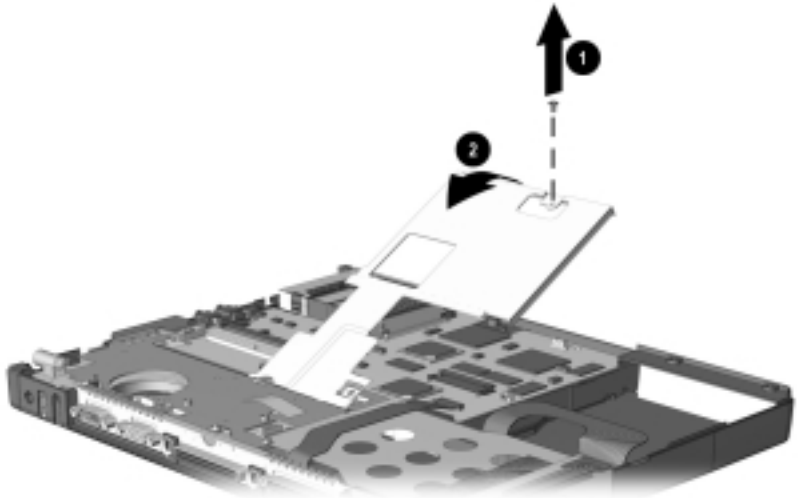

Figure 5-22. *Removing the Front Shield*

5. Remove the front shield.
- Reverse the removal procedure described above to replace the front shield.

5.14 Diskette Drive (Armada V300 only)

Diskette Drive Spare Part Number Information

Diskette drive

160537-001

Removing the Diskette Drive

1. Prepare the computer for disassembly (Section 5.3) and, in the order below, remove the following components:
 - touch button (Section 5.6)
 - keyboard (Section 5.7)
 - display assembly (Section 5.9)
 - LED board (Section 5.11)
 - top cover (Section 5.12).
2. Release the ZIF connector that connects the diskette drive ❶ (Figure 5-23).
3. Disconnect the diskette drive cable ❷.
4. Remove the screw that secures the diskette drive to the base enclosure ❸.
5. Lift up on the back of the diskette drive ❹ and remove it.

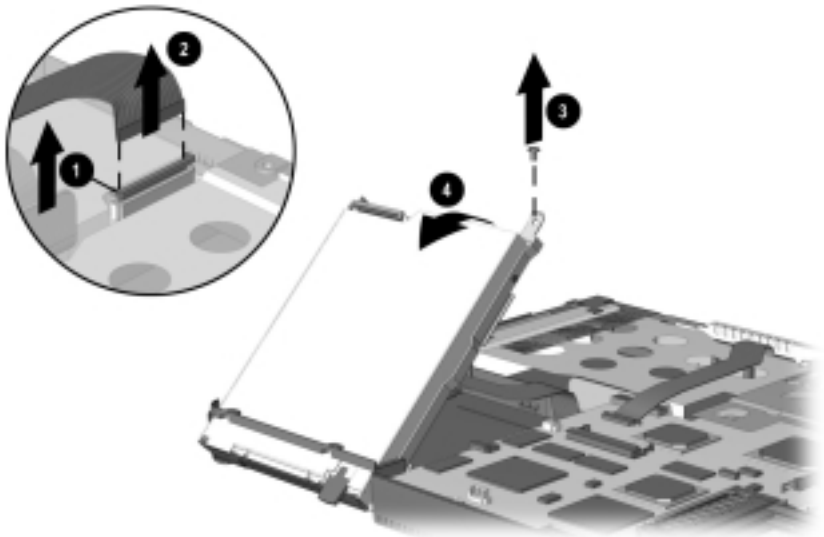

Figure 5-23. Removing the Diskette Drive

Reverse the removal procedure described above to replace the diskette drive.

5.15 System Board

IMPORTANT: When replacing the system board, remove the voltage converter board and retain it for use on the new system board. A new voltage converter board is not shipped with the new system board.

Refer to Section 5.16 for voltage converter board removal procedures.

System Board Spare Part Number Information

Armada E500 only

(all with 64 MB SDRAM)	
Intel Pentium III 700-MHz processor (use only with config. codes beginning with "DX" and "FFH")	190804-001
Intel Pentium III 650-MHz processor (use only with config. codes beginning with "DPB" and config. codes "FFD5" through "FFD8")	177751-001
Intel Pentium III 600-MHz processor (use only with config. codes beginning with "DN9" and config. codes "FFD1" through "FFD4")	177750-001
Intel Pentium III 500-MHz processor (use only with config. codes beginning with "DNM", "DNN", and "DVM", and config. code "DN83")	165102-001
Intel Pentium III 450-MHz processor (use only with config. codes beginning with "CZQ" and config. codes "DN84" and "DN85")	165101-001
Intel Pentium II 400-MHz processor (use only with config. codes beginning with "DC" and config. codes "DN81" and "DN82")	159528-001
Intel Pentium II 366-MHz processor (use only with config. codes beginning with "DJC")	159527-001

Continued

System Board *continued*

Armada V300 only

Intel Celeron 500-MHz processor with 64 MB SDRAM (use only with config. codes beginning with “DVR”)	177748-001
Intel Celeron 466-MHz processor with 64 MB SDRAM (use only with config. codes beginning with “DVP”)	177747-001
Intel Celeron 466-MHz processor with 64 MB SDRAM (use only with config. codes beginning with “CXX” and “DVQ” and config. codes “DJD3” and “DJD4”)	160535-001
Intel Celeron 400-MHz processor with 64 MB SDRAM (use only with config. codes beginning with “CXW” and config. codes “DJD1” and “DJD2”)	160534-001
Intel Celeron 400-MHz processor with 32 MB SDRAM (use only with config. codes beginning with “CXV”)	159540-001

Removing the System Board

1. Prepare the computer for disassembly (Section 5.3) and, in the order below, remove the following components:
 - modem or modem/Network Interface Card (Section 5.5)
 - touch button (Section 5.6)
 - keyboard (Section 5.7)
 - display assembly (Section 5.9)
 - LED board (Section 5.11)
 - top cover (Section 5.12)
 - front shield (Section 5.13)
 - diskette drive (Section 5.14, Armada V300 only).

2. Turn the computer bottom side up with the front facing forward.
3. Disconnect the battery terminal cable from the system board (Figure 5-24).

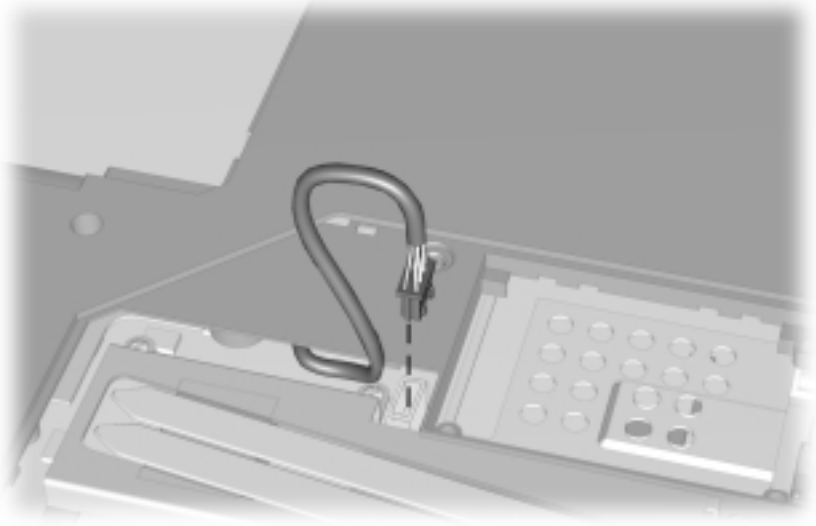

Figure 5-24. *Disconnecting the Battery Terminal Cable*

4. Turn the computer top side up with the rear panel facing forward.
5. Remove the two bushing guides ❶ that secure the system board to the I/O bracket (Figure 5-25).
6. Remove the three screws ❷ that secure the system board to the base enclosure.
7. Lift the system board straight out of the base enclosure ❸.

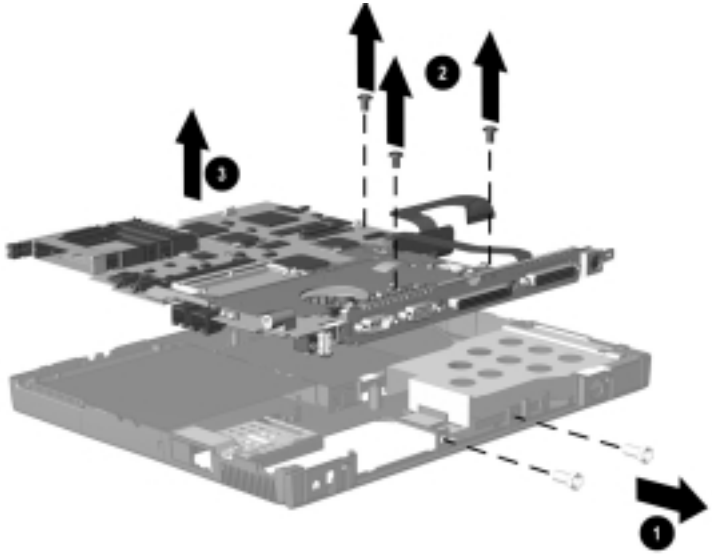

Figure 5-25. *Removing the System Board*

Reverse the removal procedure described above to replace the system board.

5.16 Voltage Converter Board

IMPORTANT: When replacing the system board, remove the voltage converter board and retain it for use on the new system board. A new voltage converter board is not shipped with the new system board.

Voltage Converter Board Spare Part Number Information

Voltage converter board	152928-001
-------------------------	------------

Removing the Voltage Converter Board

1. Prepare the computer for disassembly (Section 5.3) and, in the order below, remove the following components:
 - modem or modem/Network Interface Card (Section 5.5)
 - touch button (Section 5.6)
 - keyboard (Section 5.7)
 - display assembly (Section 5.9)
 - LED board (Section 5.11)
 - top cover (Section 5.12)
 - front shield (Section 5.13)
 - diskette drive (Section 5.14, Armada V300 only)
 - and system board (Section 5.15).
2. Turn the system board bottom side up and position the board so the I/O bracket faces forward.

3. Lift the left and right edges of the voltage converter board to disconnect it from the system board (Figure 5-26).

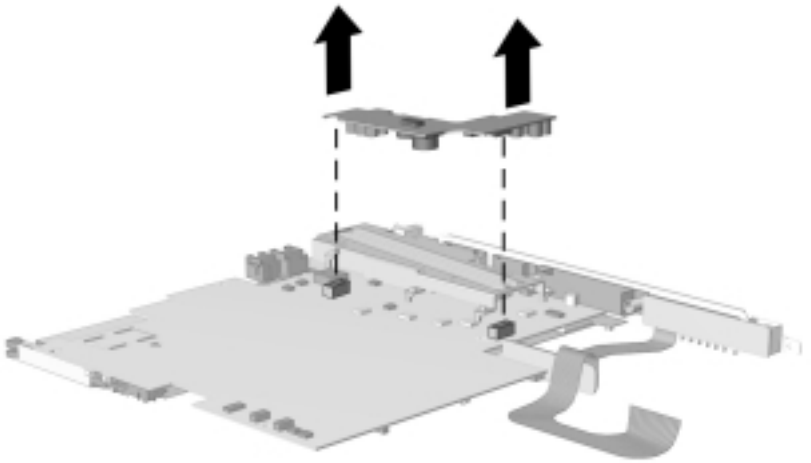

Figure 5-26. *Removing the Voltage Converter Board*

4. Remove the voltage converter board.

Reverse the removal procedure described above to replace the voltage converter board.

5.17 Fan

IMPORTANT: The fan is to be replaced only by central repair depot personnel.

Fan Spare Part Number Information

Fan

159535-001

Removing the Fan

1. Prepare the computer for disassembly (Section 5.3) and, in the order below, remove the following components:
 - modem or modem/Network Interface Card (Section 5.5)
 - touch button (Section 5.6)
 - keyboard (Section 5.7)
 - display assembly (Section 5.9)
 - LED board (Section 5.11)
 - top cover (Section 5.12)
 - front shield (Section 5.13)
 - diskette drive (Section 5.14, Armada V300 only)
 - and system board (Section 5.15).
2. Turn the system board bottom side up and position the board so the I/O bracket faces forward.

3. Remove the six screws that secure the fan and heat sink to the system board ❶ (Figure 5-27).
4. Disconnect the fan cable from the system board ❷.
5. Remove the fan and heat sink from the system board ❸.

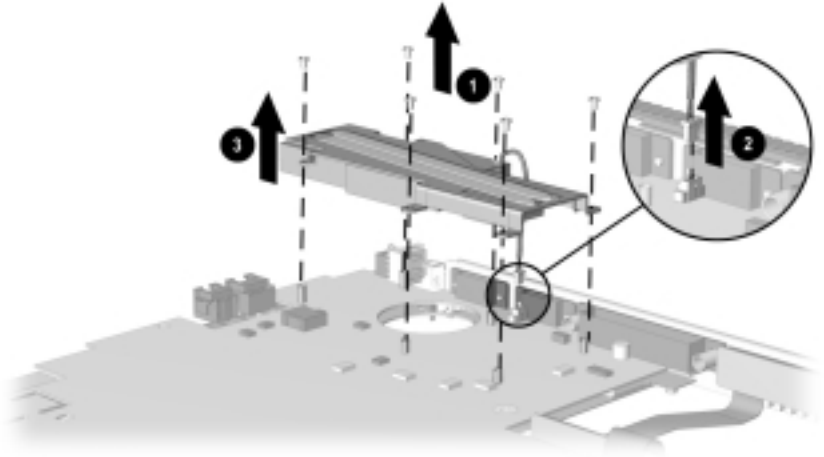

Figure 5-27. Removing the Fan and Heat Sink

6. Remove the two screws that secure the fan to the heat sink ❶ (Figure 5-28).
7. Remove the fan from the heat sink ❷.

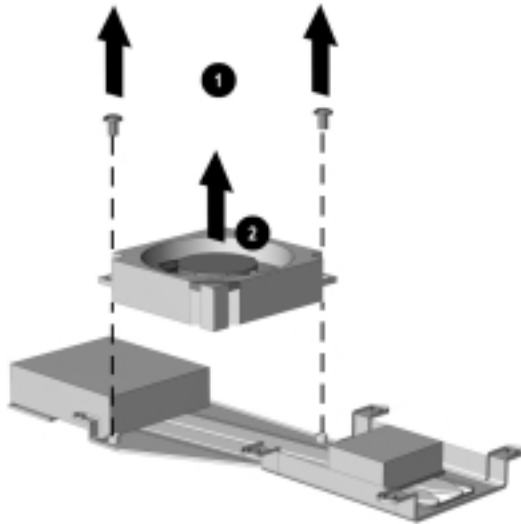

Figure 5-28. *Removing the Fan*

Reverse the removal procedure described above to replace the fan and heat sink.

chapter 6

SPECIFICATIONS

This chapter provides physical and performance specifications for the Armada E500 and Armada V300 Personal Computers.

Table 6-1 Computer		
	U.S.	Metric
Dimensions		
Height	1.65 in.	41.8 cm
Depth	9.99 in	316.0 cm
Width	12.40 in	254.0 cm
Weight	5.7 to 7.0 pounds, depending on configuration	2.60 to 3.20 kilograms, depending on configuration
Standalone (Battery) Power Requirements		
Nominal operating voltage (Li ion)	10.8 VDC	
Average operating power	15 W	
Peak operating power	30 W	
AC Adapter Power Requirements		
Rated input voltage	90 - 264 VAC RMS (auto switching)	
Rated input current	< 60 W	
Rated frequency	47 to 63 Hz	
Temperature		
Operating	50 to 98°F	10 to 35°C
Nonoperating	-4 to 140°F	-20 to 60°C
Relative Humidity (non-condensing)		
Operating	10 to 90%	
Nonoperating	5 to 95%, 101.6°F/38.7°C Maximum Wet Bulb	

Continued

Table 6-1 *continued*

	U.S.	Metric
Altitude (unpressurized)		
Operating	0 to 10,000 ft.	0 to 3048 m.
Nonoperating	0 to 30,000 ft.	0 to 9144 m.
Shock		
Operating	10 G, 11 ms, half sine	
Nonoperating	240 G, 2 ms, half sine	
Vibration		
Operating	0.5 G zero to peak, 10 to 500 Hz, 0.25 oct/min.	
Nonoperating	1.5 G zero to peak, 10 to 500 Hz, 0.50 oct/min.	

NOTE: Applicable product safety standards specify thermal limits for plastic surfaces. The computer operates well within this range of temperatures.

Table 6-2
14.1-inch XGA, TFT Display

	U.S.	Metric
Dimensions		
Height	8.46 in.	21.50 cm.
Width	11.22 in.	28.50 cm.
Diagonal	14.10 in.	35.81 cm.
Number of Colors	Up to 16.8 million	
Contrast Ratio	150:1	
Brightness	120 nits minimum, 150 nits typical	
Pixel Resolution		
Pitch		0.264 × 0.264 mm
Format	1024 × 768	
Configuration	RGB Stripe	
Backlight	Edge Lit, bottom	
Total Power Consumption		
	4.2 W	

Table 6-3
13.3-inch XGA, TFT Display

	U.S.	Metric
Dimensions		
Height	7.98 in.	20.28 mm
Width	10.64 in.	27.03 mm
Diagonal	13.30 in.	33.79 mm
Number of Colors	Up to 16.8 million	
Contrast Ratio	150:1	
Brightness	120 nits minimum, 150 nits typical	
Pixel Resolution		
Pitch		0.264 × 0.264 MM
Format	1024 × 768	
Configuration	RGB stripe	
Backlight	Edge lit, bottom	
Total Power Consumption	4.0 W	

Table 6-4
12.1-inch SVGA, TFT Display

	U.S.	Metric
Dimensions		
Height	9.70 in.	24.60 cm.
Width	7.24 in.	18.40 cm.
Diagonal	12.10 in.	30.70 cm.
Number of Colors	Up to 16.8 million	
Contrast Ratio	150:1	
Brightness	120 nits minimum, 150 nits typical	
Pixel Resolution		
Pitch		0.300 × 0.300 mm
Format	800 × 600	
Configuration	RGB Stripe	
Backlight	Edge Lit	
Total Power Consumption	3.5 W	

Table 6-5
12.1-inch SVGA, STN Display

	U.S.	Metric
Dimensions		
Height	9.70 in.	24.60 cm.
Width	7.24 in.	18.40 cm.
Diagonal	12.10 in.	30.70 cm.
Number of Colors	Up to 16.8 million	
Contrast Ratio	40:1	
Brightness	> 90 nits minimum typical	
Pixel Resolution		
Pitch		0.300 × 0.300 mm
Format	800 × 600	
Configuration	RGB Stripe	
Backlight	Edge Lit	
Total Power Consumption	3.5 W	

**Table 6-6
Hard Drives**

	18.0 GB	12.0 GB	10.0 GB	6.0 GB	4.3 GB
User capacity per drive	18.0 GB	12.0 GB	10.0 GB	6.0 GB	4.3 GB
Drive type	65	65	65	65	65
Drive height (with drive frame, in mm)	9.5	9.5	9.5	9.5	9.5
Drive width (with drive frame, in mm)	70.0	70.0	70.0	70.0	70.0
2.5-inch form factor	Yes	Yes	Yes	Yes	Yes
Sector interleave	1:1	1:1	1:1	1:1	1:1
Interface type	ATA-4	ATA-4	ATA-4	ATA-4	ATA-4
Seek times (typical, including setting)					
Single track	2.3 ms	2.3 ms	2.3 ms	2.3 ms	2.3 ms
Average	12.0 ms	12.0 ms	12.0 ms	12.0 ms	12.0 ms
Full stroke	23.0 ms	23.0 ms	23.0 ms	23.0 ms	23.0 ms
Physical configuration					
Cylinders	21620	15880	11968	7442	5335
Heads	16	16	16	16	16
Sectors per track	345 - 580	270 - 420	190 - 330	121 - 200	87 - 144
Bytes per sector	512	512	512	512	512
Logical configuration					
Cylinders	29595	22415	16383	10301	7382
Heads	16	16	16	16	16
Sectors per track	63	63	63	63	63
Bytes per sector	512	512	512	512	512
Buffer size	512 K	512 K	512 K	512 K	512 K
Disk rotational speed (rpm)	4200	4200	4200	4200	4200
Transfer rates					
Interface (mbytes/sec)	16.6	16.6	16.6	16.6	16.6
Media (mbytes/sec)	111.4 - 186.3	77.0 - 129.8	69.0 - 118.0	38.5 - 64.9	27.6 - 46.5

NOTE: Certain restrictions and exclusions apply. Consult the Compaq Customer Support Center for details.

Table 6-7
Diskette Drive

Diskette Size	3.5 inch
Light	On system
Height	0.5 in. / 12.7 mm
Bytes per Sector	512
Sectors per Track	
High Density	18 (1.44 MB) / 15 (1.2 MB)
Low Density	9
Tracks per Side	
High Density	80 (1.44 MB) / 80 (1.2 MB)
Low Density	80
Read/Write Heads	2
Average Seek Times	
Track-to-Track (high/low)	3 ms / 6 ms
Average (high/low)	95 ms / 174 ms
Settling Time	15 ms
Latency Average	100 ms

Table 6-8
CD-ROM Drive

Applicable Disc	CD-ROM (Mode 1, 2, and 3) CD-XA ready (Mode 2, Form 1 and 2) CD-I ready (Mode 2, Form 1 and 2) CD-R (read only) CD Plus Photo CD (Single/Multi-session) CD-Extra Video CD CD-WO (fixed packets only) CD-Bridge
Center Hole Diameter	.59 in. / 15 mm
Disc Diameter	12 cm, 8 cm
Disc Thickness	1.2 mm
Track Pitch	1.6 μ m
Access Time	
Random	< 150 ms
Full Stroke	< 300 ms
Cache Buffer	128 KB
Data Transfer Rate	
Sustained, 16X	2400 KB/sec (150 KB/sec at 1X)
Variable	1500 to 3600 KB/sec (10X to 24X)
Normal PIO Mode 4 (single burst)	16.66 MB/sec
Start-up time	< 8 seconds
Stop time	< 4 seconds

Table 6-9
DVD-ROM Drive

Applicable Disc	DVD-5, DVD-9, DVD-10 CD-ROM mode 1, mode 2 CD-Digital Audio CD-XA mode 2 (Form 1, Form 2) CD-I mode 2 (Form 1 and Form 2) CD-I Ready CD-Bridge CD-R Photo CD (single/multisession)
Center Hole Diameter	.59 in. / 15 mm
Disc Diameter	12 cm, 8 cm
Disc Thickness	1.2 mm
Track Pitch	.74 μ m
Access Time	
Random	< 150 ms
Full Stroke	< 225 ms
Audio Output Level	
Line Out	0.7 V rms
Headphone	none
Cache Buffer	128 KB
Data Transfer Rate (typical, including setting)	
Sustained, 1X CD rate	150 KB/sec
Sustained, 16X CD rate	2400 KB/sec
Sustained, 1X DVD rate	1380 KB/sec
Sustained, 4X DVD rate	5520 KB/sec
Normal IO Mode 4 (single burst)	16.6 MB/sec
Start time	< 15 seconds
Stop time	< 6 seconds

Table 6-10
LS-120 SuperDisk Drive

	1.68 MB DMF	1.44 MB	1.2 MB	1.2 MB	720 KB
Formatted capacity (bytes)	1,720,320	1,474,560	1,261,568	1,228,800	737,280
Sector size (bytes)	512	512	1,024	512	512
Sectors	3,360	2,880	1,232	2,400	1,440
Magnetic tracks surface	80	80	77	80	80
Optical servo tracks/surface	N/A	N/A	N/A	N/A	N/A
Sectors/track	21	18	8	15	9
Sector interleave	2:1	1:1	1:1	1:1	1:1
Spare sectors	0	0	0	0	0
Zones (each side)	1	1	1	1	1
Average random seek	70 ms	70 ms	70 ms	70 ms	70 ms
Track-to-track seek	25 ms	25 ms	25 ms	25 ms	25 ms
Max single seek	170 ms	170 ms	170 ms	170 ms	170 ms
Average latency	41.67 ms	41.67 ms	41.67 ms	41.67 ms	41.67 ms

Continued

Table 6-10 *Continued*

	1.68 MB DMF	1.44 MB	1.2 MB	1.2 MB	720 KB
Motor RPM	720± 0.5%	720± 0.5%	720± 0.5%	720± 0.5%	720± 0.5%
Motor start time	800 ms	800 ms	800 ms	800 ms	800 ms
Track density	135 TPI	135 TPI	135 TPI	135 TPI	135 TPI
Track width	125 µm	125 µm	125 µm	125 µm	125 µm
Encoding method	MFM	MFM	MFM	MFM	MFM
Max flux density	17,334 FCI	17,334 FCI	17,334 FCI	17,334 FCI	17,334 FCI
Recording density	17,334 BPI	17,334 BPI	17,334 BPI	17,334 BPI	17,334 BPI
Nominal transfer rate	150 KB/sec	150 KB/sec	125 KB/sec	125 KB/sec	75 KB/sec
Nominal sustained transfer rate across interface	65 KB/sec read, 32 KB/sec write	55 KB/sec read, 28 KB/sec write	49 KB/sec read, 25 KB/sec write	46 KB/sec read, 23 KB/sec write	28 KB/sec read, 14 KB/sec write
Buffer transfer rate	4.0 MB/sec	4.0 MB/sec	4.0 MB/sec	4.0 MB/sec	4.0 MB/sec

Table 6-11
AC Adapter

	U.S.	Metric
Dimensions		
Height	1.15 in.	2.92 cm
Length	2.38 in.	6.03 cm
Width	1.40 in.	3.60 cm
Weight	0.66 lb.	0.30 kg
Power Supply (input)		
Operating voltage	90 to 260 VAC RMS	
Operating current	1.1 A RMS	
Operating frequency range	47 to 63 Hz AC	
Maximum transient	4/50 kV	

**Table 6-12
Lithium Ion Battery Packs**

	U.S.	Metric
Dimensions		
9-cell primary battery pack		
Height	.81 in.	2.05 cm
Length	5.60 in.	14.30 cm
Width	3.80 in.	9.60 cm
Weight	1.01 lb.	462 g
6-cell primary battery pack		
Height	.81 in.	2.05 cm
Length	5.60 in.	14.30 cm
Width	3.80 in.	9.60 cm
Weight	0.73 lb.	334 g
6-cell MultiBay battery pack		
Height	.53 in.	1.35 cm
Length	5.50 in.	14.00 cm
Width	5.23 in.	13.30 cm
Weight	0.84 lb.	382 g

Energy and Environmental Requirements are the same for all battery packs.

Energy

9-cell	
Voltage	10.8 V
Amp-hour capacity	4.8 AH
Watt-hour capacity	51.8 AH
6-cell	
Voltage	10.8 V
Amp-hour capacity	3.2 AH
Watt-hour capacity	34.5 AH

Environmental Requirements

Temperature		
Operating	50°F to 95°F	10°C to 35°C
Non-operating	-12°F to 140°F	-25°C to 60°C

**Table 6-13
System DMA**

Hardware DMA	System Function
DMA0	Available for audio
DMA1	Entertainment Audio (Default; Alternate = DMA0, DMA3, None)
DMA2	Diskette Drive
DMA3	ECP Parallel Port LPT1 (Default; Alternate = DMA 0, none)
DMA4	DMA Controller Cascading (Not available)
DMA5	Available for PC Card
DMA6	Not Assigned
DMA7	Not Assigned

Note: PC Card controller can use DMA 1, 2, or 5.

Table 6-14
System Interrupts

Hardware IRQ	System Function
IRQ0	System timer
IRQ1	Keyboard controller
IRQ2	Cascaded
IRQ3	COM2
IRQ4	COM1
IRQ5	Audio (default)*
IRQ6	Diskette drive
IRQ7	Parallel port
IRQ8	Real Time Clock (RTC)
IRQ9	Infrared
IRQ10	System use
IRQ11	System use
IRQ12	Internal Point Stick or External Mouse
IRQ13	Coprocessor (Not available to any peripheral)
IRQ14	IDE Interface (Hard Disk and CD-ROM Drive)
IRQ15	Fixed Disk Drives on the expansion base or convenience base.

NOTES: PCMCIA cards may assert IRQ3, IRQ4, IRQ5, IRQ7, IRQ9, IRQ10, IRQ11, or IRQ15. Either the infrared or the serial port may assert IRQ3 or IRQ4.

*Default configuration; audio possible configurations are: IRQ5, IRQ7, IRQ9, IRQ10, or none.

**Table 6-15
System I/O Addresses**

I/O Address (Hex)	System Function (Shipping Configuration)
000 - 00F	DMA Controller no. 1
010 - 01F	Unused
020 - 021	Interrupt Controller no. 1
022 - 024	Opti Chipset Configuration registers
025 - 03F	Unused
02E - 02F	87334 "Super IO" configuration for CPU
040 - 043	Counter/Timer Registers
044 - 05F	Unused
060	Keyboard Controller
061	Port B
062 - 063	Unused
064	Keyboard Controller
065 - 06F	Unused
070 - 071	NMI Enable/Real Time Clock
072 - 07F	Unused
080 - 08F	DMA Page Registers
090 - 091	Unused
092	Port A
093 - 09F	Unused
0A0 - 0A1	Interrupt Controller no. 2
0A2 - 0BF	Unused
0C0 - 0DF	DMA Controller no. 2
0E0 - 0EF	Unused
0F0 - 0F1	Coprocessor Busy Clear/Reset
0F2 - 0FF	Unused
100 - 16F	Unused
170 - 177	Secondary Fixed Disk Controller
178 - 1EF	Unused
1F0 - 1F7	Primary Fixed Disk Controller
1F8 - 200	Unused

Continued

Table 6-15 *Continued*

I/O Address (Hex)	System Function (Shipping Configuration)
201	Joystick (Decoded in ESS1688)
202 - 21F	Unused
220 - 22F	Entertainment Audio
230 - 26D	Unused
26E - 26	National 87334 "Super IO" Controller in expansion base/convenience base
278 - 27F	Unused
280 - 2AB	Unused
2A0 - 2A7	Expansion base/convenience base PC Card DMA Selection, Hard Drive Reset, IDE Select, MultiBay Device Identification
2A8 - 2E7	Unused
2E8 - 2EF	Reserved Serial Port
2F0 - 2F7	Unused
2F8 - 2FF	Infrared port
300 - 31F	Network Interface in expansion base/convenience base (Default; Alternate is 320, 340, or 360h)
320 - 36F	Unused
370 - 377	Secondary Floppy Controller (In expansion base/convenience base when a floppy is installed in the CPU)
378 - 37F	Parallel Port (LPT1/Default)
380 - 387	Unused
388 - 38B	FM Synthesizer - OPL3
38C - 3AF	Unused
3B0 - 3BB	VGA
3BC - 3BF	Reserved (Parallel Port/No EPP Support)
3C0 - 3DF	VGA
3E0 - 3E1	PC Card Controller in CPU
3E2 - 3E3	PC Card Controller in expansion base/convenience base
3E8 - 3EF	Internal Modem
3F0 - 3F7	"A" Diskette Controller
3F8 - 3FF	Serial Port (COM1/Default)
CF8 - CFB	PCI Configuration Index Register (PCIDIV0-1)
CFC - CFF	PCI Configuration Data Register (PCIDIV0-1)

Table 6-16
System Memory Map

Size	Memory Address	System Function
640 K	00000000 - 0009FFFF	Base Memory
128 K	000A0000 - 000BFFFF	Video Memory
48 K	000C0000 - 000CBFFF	Video BIOS
160 K	000C8000 - 000E7FFF	Unused
64 K	000E8000 - 000FFFFF	System BIOS
15 M	00100000 - 00FFFFFF	Extended Memory
58 M	01000000 - 047FFFFF	Super Extended Memory
58 M	04800000 - 07FFFFFF	Unused
2 M	08000000 - 080FFFFF	Video Memory (Direct Access)
4 G	08200000 - FFFFFFFFFF	Unused
64 K	FFFF0000 - FFFFFFFF	System BIOS

appendix A

CONNECTOR PIN ASSIGNMENTS

Table A-1
RJ-11

Connector	Pin	Signal
	1	NC_J3A
	2	NC_J3B
	3	TIP
	4	RING
	5	NC_J3C
	6	NC_J3D
	7	Unused
	8	Unused

Table A-2
Serial Connector



Pin	Signal	Pin	Signal
1	Carrier Detect	6	Data Set Ready
2	Receive Data	7	Ready to Send
3	Transmit Data	8	Clear to Send
4	Data Terminal Ready	9	Ring Indicator
5	Ground		

Table A-3
Microphone Jack

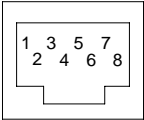
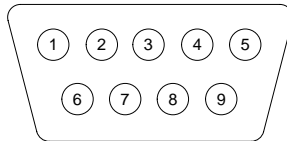
Connector	Pin	Signal
	1	Audio in
	2	Ground

Table A-4
Stereo Speaker/Headphone Jack

Connector	Pin	Signal
	1	Audio out
	2	Ground

Table A-5
Stereo Line-in Jack

Connector	Pin	Signal
	1	Audio in
	2	Ground

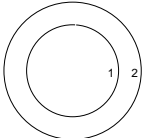
Table A-6
Parallel Connector

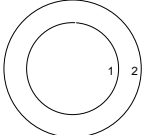

Pin	Signal	Pin	Signal
1	Strobe	14	Auto Linefeed
2	Data Bit 0	15	Error
3	Data Bit 1	16	Initialize Printer
4	Data Bit 2	17	Select In
5	Data Bit 3	18	Ground
6	Data Bit 4	19	Ground
7	Data Bit 5	20	Ground
8	Data Bit 6	21	Ground
9	Data Bit 7	22	Ground
10	Acknowledge	23	Ground
11	Busy	24	Ground
12	Paper End	25	Ground
13	Select		

**Table A-7
Docking Connector**

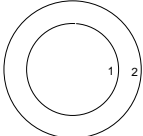
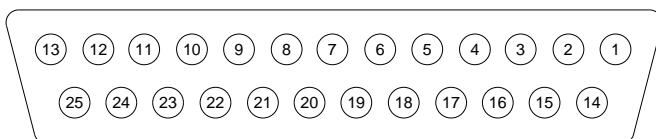
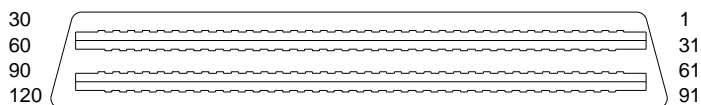

Pin	Signal	Pin	Signal
1	EBOXL	29	XA3/R IN
2	AGND	30	MID0/MIC IN
3	EBOXS1	31	AUGND
4	RED	32	XA0/L OUT
5	AGND	33	XSD/MIC SN
6	GREEN	34	XA1/R OUT
7	AGRD	35	GND
8	BLUE	36	GND
9	AGND	37	EXPCLK2
10	VSYNC	38	+3.3V
11	HSYNC	39	EXPCLK0
12	DDC DAT	40	+5V (8051VCC)
13	DDC CLK	41	EXPCLK
14	GND	42	EBOXS2
15	INDEX	43	GND
16	RDATA	44	EBOXL
17	TRK0	45	EBOXL /GND
18	WDATA	46	SRDY
19	WGATE	47	EBOXS1 /GND
20	STEP	48	RI1 EX
21	DIR	49	GND
22	POWER ON	50	SLCT LD0
23	SYS RESET	51	PE LD1
24	GND	52	ACK LD2
25	DSKCHG	53	BUSY LD3
26	+5 V (VDD)	54	GND
27	AUGND	55	STRB LD4
28	XA2/L IN	56	ALF LD5

Continued

Table A-7 *continued*

Pin	Signal	Pin	Signal
57	INIT LD6	91	PS2 VCC
58	SLCTIN LD7	92	SERIRQ
59	GND	93	PS2 CLK
60	PDATA0 LD8	94	EXPREQ
61	PDATA1 LD9	95	AD[29]
62	PDATA2 LD10	96	AD[31]
63	PDATA3 LD11	97	AD[30]
64	GND	98	AD[28]
65	PDATA4 LD12	99	AD[26]
66	PDATA5 LD13	100	GND
67	PDATA6 LD14	101	AD[24]
68	PDATA7 LD15	102	AD[22]
69	GND	103	AD[20]
70	ERROR LCLK	104	AD[18]
71	RXD1 LVREQ	105	AD[16]
72	TXD1 LCREQ	106	GND
73	RTS1 LEN	107	AD[15]
74	GND	108	AD[13]
75	CTS1 LIIC CLK	109	AD[11]
76	DTR1 LIIC DAT	110	AD[09]
77	DSR1 EX	111	GND
78	DCD1 EX	112	AD[06]
79	12C DATA	113	AD[04]
80	GND	114	AD[02]
81	12C CLK	115	AD[00]
82	GND	116	GND
83	HDSEL	117	FRAME
84	GND	118	TRDY
85	WPROT	119	STOP
86	EBOXS2 /GND	120	PAR
87	ERDY	121	CBE0
88	EBOXL /GND	122	CBE1
89	FLUSHREQ	123	GND
90	MEMACK	124	KB CLK

Continued

Table A-7 *continued*

Pin	Signal	Pin	Signal
125	RSVD1/M CTRL2	151	AD[12]
126	XSC/L OUT SN	152	AD[10]
127	RSVD2/M OFF HOOK	153	AD[08]
128	KB DATA	154	GND
129	MGND	155	AD[07]
130	STANDBY	156	AD[05]
131	M DRZP	157	AD[03]
132	M DRXN	158	AD[01]
133	VBATT	159	GND
134	EXPGNT	160	CBE3
135	VBATT	161	CBE2
136	GND	162	IRDY
137	VBATT	163	DEVSEL
138	PS2 DATA	164	LOCK
139	VBATT	165	OERR
140	AD[25]	166	SERR
141	VBATT	167	GND
142	AD[27]	168	RSVD3
143	VBATT	169	M 12C CLK
144	AD[23]	170	M 12C DATA
145	GND	171	M RING
146	AD[21]	172	MGND
147	AD[19]	173	M DXTN
148	AD[17]	174	GND
149	GND	175	M DXTP
150	AD[14]	176	MSTRBAT

Table A-8
External Keyboard/Mouse Connector

Connector	Pin	Signal
	1	Keyboard/Mouse DATA
	2	Keyboard/Mouse DATA
	3	Ground
	4	+5 VDC
	5	Keyboard/Mouse CLK
	6	Keyboard/Mouse CLK

Table A-9
External Monitor Connector



Pin	Signal	Pin	Signal
1	Red Analog	9	NC
2	Green Analog	10	Ground
3	Blue Analog	11	NC
4	NC	12	DDC Data
5	Ground	13	Horizontal Sync
6	Ground	14	Vertical Sync
7	Ground	15	DDC Clock
8	Ground		

appendix **B**

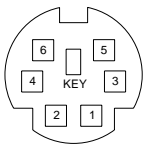
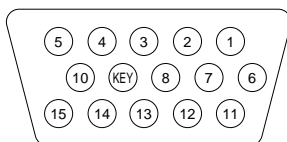
POWER CORD SET REQUIREMENTS

3-Conductor Power Cord Set

The wide range input feature of the Armada E500 and Armada V300 Series of Personal Computers permits them to operate from any line voltage from 100 to 120 or 220 to 240 volts AC.

The power cord sets received with the computers meets the requirements for use in the country where the equipment is purchased.

Power cord sets for use in other countries must meet the requirements of the country where the computer is used. For more information on power cord set requirements, contact a Compaq authorized reseller or service provider.

General Requirements

The requirements listed below are applicable to all countries:

1. The length of the power cord set must be at least 5.00 feet (1.5 m) and a maximum of 6.50 feet (2.0 m).
2. All power cord sets must be approved by an acceptable accredited agency responsible for evaluation in the country where the power cord set will be used.
3. The power cord set must have a minimum current capacity of 10A and a nominal voltage rating of 125 or 250 volts AC, as required by each country's power system.
4. The appliance coupler must meet the mechanical configuration of an EN 60 320/IEC 320 Standard Sheet C13 connector, for mating with appliance inlet on the back of the computer.

Country-Specific Requirements

3-Conductor Power Cord Set Requirements—By Country

Country	Accredited Agency	Applicable Note Numbers
Australia	EANSW	1
Austria	OVE	1
Belgium	CEBC	1
Canada	CSA	2
Denmark	DEMKO	1
Finland	FIMKO	1
France	UTE	1
Germany	VDE	1
Italy	IMQ	1
Japan	JIS	3
The Netherlands	KEMA	1
Norway	NEMKO	1
Sweden	SEMKO	1
Switzerland	SEV	1
United Kingdom	BSI	1
United States	UL	2

Notes

1. The flexible cord must be <HAR> Type HO5VV-F, 3-conductor, 1.0 mm² conductor size. Power cord set fittings (appliance coupler and wall plug) must bear the certification mark of the agency responsible for evaluation in the country where it will be used.
2. The flexible cord must be Type SPT-3 or equivalent, No. 18 AWG, 3-conductor. The wall plug must be a two-pole grounding type with a NEMA 5-15P (15A, 125V) or NEMA 6-15P (15A, 250V) configuration.
3. The appliance coupler, flexible cord, and wall plug must bear a "T" mark and registration number in accordance with the Japanese Dentori Law. The flexible cord must be Type VCT or VCTF, 3-conductor, 0.75mm² conductor size. The wall plug must be a two-pole grounding type with a Japanese Industrial Standard C8303 (15A, 125V) configuration.

INDEX

A

- AC Adapter
 - spare part number, 3-12
 - specifications, 6-10
- air vent
 - illustrated, 1-16
- Asset Management, 1-10
- asset tag number, 1-10
- audio bass port
 - illustrated, 1-14

B

- battery
 - bay
 - illustrated, 1-14
 - light
 - illustrated, 1-14
 - pack
 - 6-cell
 - spare part number, 3-7
 - 9-cell
 - spare part number, 3-7
 - illustrated, 3-6
 - MultiBay
 - spare part number, 3-7
 - specifications, 6-11
 - release latch
 - illustrated, 1-24
 - terminal cable
 - disconnecting, 5-32
- beep codes, 2-8
- boot options, 2-13

C

- cables, 4-2
- caps lock
 - key
 - illustrated, 1-20
 - light
 - illustrated, 1-22

- CD-ROM drive
 - illustrated, 3-2, 3-11
 - space saver
 - illustrated, 3-10
 - spare part number, 3-9, 3-11
 - specifications, 6-7
- combination modem/NIC card
 - installing, 5-6
 - Type II V.90
 - spare part number, 3-9, 5-5
- Compaq
 - utilities, 2-9
- computer
 - components
 - bottom, 1-24
 - keyboard, 1-20, 1-22
 - left side, 1-16
 - rear, 1-18
 - top, 1-14
 - features, 1-8
 - feet, 5-4
 - illustrated, 3-10
 - models, 1-2, 1-4
 - specifications, 6-1
- Computer Setup, 2-9
- Configuration Management, 1-13
- configuration utilities, 2-9
- connector
 - pin assignments, A-1
- connectors, 4-2
- CPU base enclosure
 - illustrated, 3-8
 - spare part number, 3-9
- cursor-control
 - keys
 - illustrated, 1-20

D

- default settings, 2-15
- initialization, 2-15
- power, 2-16
- security, 2-16
- design overview, 1-26

- device
 - options, 2-13
 - security, 2-12
- diagnostics, 2-9
- disassembly
 - preparing the computer, 5-3
 - reference chart, 5-2
- diskette drive, 5-29
 - bezel
 - illustrated, 3-2, 3-10
 - removing, 5-23
 - cable
 - illustrated, 3-11
 - fixed
 - illustrated, 1-14, 3-8
 - spare part number, 3-9, 3-11
 - illustrated, 3-11
 - release latch
 - illustrated, 1-24
 - removable
 - illustrated, 3-8
 - spare part number, 3-9, 3-11, 5-29
 - removing, 5-29
 - specifications, 6-6
- display
 - release latch
 - illustrated, 1-14
 - removing, 5-16
 - screw cover
 - illustrated, 3-10
 - switch
 - illustrated, 1-20
- display assembly, 5-16
 - 12.1-inch, STN
 - spare part number, 3-3, 5-16
 - specifications, 6-4
 - 12.1-inch, TFT
 - spare part number, 3-3, 5-16
 - specifications, 6-4
 - 13.3-inch, HPA
 - spare part number, 3-3, 5-16
 - specifications, 6-3
 - 13.3-inch, TFT
 - spare part number, 3-3, 5-16
 - specifications, 6-3
 - 14.1-inch
 - spare part number, 3-3, 5-16
 - specifications, 6-2
 - cables
 - disconnecting, 5-19
 - illustrated, 3-2
 - display assembly
 - spare part number, 5-16
 - docking
 - connector
 - illustrated, 1-18
 - pinout, A-4
 - DualBay
 - illustrated, 1-14
 - DVD-ROM drive
 - illustrated, 3-11
 - spare part number, 3-9, 3-11
 - specifications, 6-8

E

- electrostatic
 - preventing damage, 4-3
 - voltage levels, 4-6
- embedded numeric keypad
 - illustrated, 1-20
- external monitor
 - connector
 - illustrated, 1-18

F

- fan, 5-36
 - illustrated, 3-6
 - removing, 5-36
 - spare part number, 3-7, 5-36
- fatal error
 - beep codes, 2-8
 - messages, 2-7
- Fault Management, 1-11
 - alerts, 1-12
- features, 1-8
 - computer, 1-8
- feet
 - installing, 5-4
- Fn keys
 - illustrated, 1-22
- front shield, 5-28
 - illustrated, 3-10
 - removing, 5-28
- function keys
 - illustrated, 1-22

G

- grounding
 - equipment, 4-5
 - methods, 4-5

H

- hard drive
 - 10.0 GB
 - spare part number, 3-9, 3-11
 - 12.0 GB
 - spare part number, 3-9, 3-11
 - 18.0 GB
 - spare part number, 3-9, 3-11
 - 4.3 GB
 - spare part number, 3-9, 3-11
 - 6.0 GB
 - spare part number, 3-9, 3-11
 - adapter
 - spare part number, 3-12
 - cover
 - illustrated, 1-24, 3-2
 - release latch
 - illustrated, 1-24
 - screw
 - illustrated, 1-24
 - illustrated, 3-8, 3-11
 - light
 - illustrated, 1-22
 - MultiBay adapter
 - spare part number, 3-9
 - specifications, 6-5
- hardware
 - updating, 2-17
 - headphone
 - jack
 - illustrated, 1-16
 - pinout, A-2
 - heat sink
 - removing, 5-37
 - hinge cover
 - illustrated, 3-2, 3-10
 - removing, 5-17

I

- Info Messenger, 2-17
- infrared
 - port
 - illustrated, 1-16
- initialization
 - default settings, 2-15
- Intelligent Manageability, 1-10
 - Asset Management, 1-10
 - Configuration Management, 1-13
 - Fault Management, 1-11
 - alerts, 1-12
 - Security Management, 1-12
 - Web Agent, 1-10
- inventory information, 1-11

K

- keyboard
 - connector
 - illustrated, 1-18
 - pinout, A-7
 - removing, 5-10
 - with pointing stick
 - illustrated, 3-4
 - spare part number, 3-5, 5-9
 - without pointing stick
 - illustrated, 3-4
 - spare part number, 3-5, 5-9

L

- LED board, 5-22
 - illustrated, 3-2
 - removing, 5-22
 - spare part number, 3-3, 5-22
- LS-120 SuperDisk drive
 - illustrated, 3-11
 - spare part number, 3-9, 3-11
 - specifications, 6-9

M

- maintenance
 - updating system, 2-17
- maintenance and service guide
 - spare part number, 3-12
- mass storage devices
 - illustrated, 3-11
 - spare part numbers, 3-11
- memory, 5-13
 - expansion board
 - 128 MB
 - spare part number, 3-12, 5-13
 - 256 MB
 - spare part number, 3-12, 5-13
 - 32 MB
 - spare part number, 3-12, 5-13
 - 64 MB
 - spare part number, 3-12, 5-13
 - installing, 5-15
 - removing, 5-14
 - spare part number, 5-13
- messages
 - fatal error, 2-7
 - warning, 2-5
- microphone
 - jack
 - pinout, A-2
- Microsoft
 - logo key
 - illustrated, 1-20
- mini PCI
 - cover
 - illustrated, 3-10
 - mini PCI slot, 5-5
 - cover
 - illustrated, 1-24, 3-2
 - removing, 5-5
- miscellaneous
 - spare part numbers, 3-12
- Miscellaneous Plastics Kit
 - components
 - illustrated, 3-2, 3-10
 - spare part number, 3-3, 3-10
- Miscellaneous Screw Kit
 - spare part number, 3-12
- model table, 1-2, 1-4
- models
 - computer, 1-2, 1-4
- modem
 - card
 - illustrated, 3-8
 - Type II V.90
 - spare part number, 3-9, 5-5
 - installing, 5-6
- monitor
 - connector
 - pinout, A-7
- mono microphone
 - jack
 - illustrated, 1-16
- mouse
 - connector
 - illustrated, 1-18
 - pinout, A-7
 - keys
 - illustrated, 1-22
- MultiBay
 - illustrated, 1-14
 - light
 - illustrated, 1-22
 - release latch
 - illustrated, 1-24

N

- network interface card
 - illustrated, 3-2
 - installing, 5-6
 - Type II V.90
 - spare part number, 3-9
- NIC
 - installing, 5-6
- NIC card
 - illustrated, 3-2
- num lock
 - key
 - illustrated, 1-22
 - light
 - illustrated, 1-22

P

- packaging
 - precautions, 4-4
- page down
 - key
 - illustrated, 1-20
- page up
 - key
 - illustrated, 1-20
- parallel
 - connector
 - illustrated, 1-18
 - pinout, A-3
- password
 - clearing, 2-3
- PC Card
 - slots
 - illustrated, 1-16
 - space saver
 - illustrated, 3-10
- plastic parts, 4-1
- pointing stick
 - illustrated, 1-22

POST

- (Power-On Self-Test), 2-4
- error messages, 2-4
- power
 - cord
 - set requirements, B-1
 - spare part number, 3-12
 - default settings, 2-16
 - light
 - illustrated, 1-14
 - management, 1-13
 - levels, 1-13
 - switch
 - illustrated, 1-20
- Power-On Self-Test (POST), 2-4
- preparing computer for disassembly, 5-3

Q

- QuickBoot, 2-13

R

- real time clock battery
 - illustrated, 3-2, 3-10
 - removing, 5-21
- removable drives
 - preventing damage, 4-2
- Return Kit
 - spare part number, 3-12
- RJ-11
 - cover
 - illustrated, 3-10
 - jack
 - illustrated, 1-16
 - pinout, A-1
- RJ-45
 - cover
 - illustrated, 3-10
 - jack
 - illustrated, 1-16
- RTC battery
 - illustrated, 3-2, 3-10
 - removing, 5-21

S

- scroll lock
 - key
 - illustrated, 1-22
 - light
 - illustrated, 1-22
- security
 - cable slot
 - illustrated, 1-16
 - default settings, 2-16
- Security Management, 1-12
- serial
 - connector
 - illustrated, 1-18
 - pinout, A-1
 - serial number, x
 - location, 3-1, 5-1
- service consideration, 4-1
- setup
 - computer, 2-9
- software
 - Info Messenger, 2-17
 - updating, 2-17
- speaker cables
 - removing, 5-25
- specifications
 - AC adapter, 6-10
 - battery pack, 6-11
 - CD-ROM drive, 6-7
 - computer, 6-1
 - diskette drive, 6-6
 - display
 - 12.1-inch, STN, 6-4
 - 12.1-inch, TFT, 6-4
 - 13.3-inch, 6-3
 - 14-1-inch, 6-2
 - DVD-ROM drive, 6-8
 - hard drive, 6-5
 - LS-120 SuperDisk drive, 6-9
 - system DMA, 6-11
 - system I/O address, 6-13
 - system interrupts, 6-12
 - system memory map, 6-15
- static shielding materials, 4-6
- stereo
 - line-in jack
 - pinout, A-2
 - speaker
 - illustrated, 1-22
 - jack
 - pinout, A-2
 - illustrated, 1-16
- suspend
 - button
 - illustrated, 1-20
 - light
 - illustrated, 1-14
- switch cover
 - illustrated, 3-2, 3-10
 - removing, 5-18
- system
 - IDs, 2-12
 - ROM updates, 2-17
- system board, 5-29
 - Celeron 400-MHz processor, STN, 32 MB SDRAM
 - spare part number, 3-7, 5-31
 - Celeron 400-MHz processor, TFT, 64 MB SDRAM
 - spare part number, 3-7, 5-31
 - Celeron 466-MHz processor, HPA,
 - spare part number, 3-7, 5-31
 - Celeron 466-MHz processor, TFT,
 - spare part number, 3-7, 5-31
 - Celeron 500-MHz processor
 - spare part number, 3-7, 5-31
 - illustrated, 3-6
 - Pentium II 366-MHz processor
 - spare part number, 3-5, 5-30
 - Pentium II 400-MHz processor
 - spare part number, 3-5, 5-30
 - Pentium III 450-MHz processor
 - spare part number, 3-5, 5-30
 - Pentium III 500-MHz processor
 - spare part number, 3-5, 5-30
 - Pentium III 600-MHz processor
 - spare part number, 3-5, 5-30
 - Pentium III 650-MHz processor
 - spare part number, 3-5, 5-30
 - removing, 5-31
- system DMA
 - specifications, 6-11
- system I/O addresses
 - specifications, 6-13
- system interrupts
 - specifications, 6-12
- system memory map
 - specifications, 6-15

T

- technician notes, x
- tilt feet
 - illustrated, 1-14
- tools, 4-1
- top cover, 5-23
 - illustrated, 3-4
 - removing, 5-23
 - spare part number, 3-5, 5-23
- touch button
 - illustrated, 3-4
 - removing, 5-7
 - spare part number, 3-5, 5-7
- touch button with TouchPad
 - illustrated, 3-4
 - spare part number, 3-5, 5-7
- TouchPad
 - buttons
 - illustrated, 1-20
 - illustrated, 1-20
- transporting
 - precautions, 4-4
- troubleshooting
 - preliminary steps, 2-2
 - without diagnostics, 2-17
- TV
 - connector
 - illustrated, 1-16

U

- universal serial bus
 - connector
 - illustrated, 1-18
- USB
 - connector
 - illustrated, 1-18
- utilities, Compaq, 2-9

V

- voltage converter board, 5-34
 - illustrated, 3-6
 - removing, 5-34
 - spare part number, 3-7, 5-34
- volume control buttons
 - illustrated, 1-14

W

- warning messages, 2-5
- Web Agent, 1-10
- Windows
 - application key
 - illustrated, 1-20
- workstation
 - precautions, 4-4