

# **P6B40D-A5 MAINBOARD**

## **User's Manual**

**REV: 1.00**

**Date: May - 98**

\* All other product names are trademarks or copyrights of their respective owners.

---

## FCC & DOC Compliance Statement

This device complies with Part 15 of the FCC rules, operation is subject to the following two conditions.

1. This device may not cause harmful interference and,
2. This device must accept any interference received, including interference that may cause undesired operation.

This equipment has been tested and found to comply with limits for a Class B digital device, pursuant to Part 15 of the FCC rules. These limits are designed to provide reasonable protection against harmful interference in residential installations. This equipment generates, uses, and can radiate radio frequency energy, and if not installed and used in accordance with the instructions, may cause harmful interface to radio communications. However, there is no guarantee that interference will not occur in a particular installation. If this equipment does cause interference to radio or television equipment reception, which can be determined by turning the equipment off and on, the user is encouraged to try to correct the interference by one or more of the following measures:

- Reorient or relocate the receiving antenna.
- Move the equipment away from the receiver.
- Plug the equipment into an outlet on a circuit different from that to which the receiver is connected.
- Consult the dealer or an experienced radio/television technician for additional suggestions.

The FCC requires the user to be notified that any change or modifications to the equipment by the user not expressly approved by the grantee or manufacturer could void the user's authority to operate such equipment. The use of shielded cables for connection of the monitor to the graphics card is required to assure compliance with FCC regulations.

---

# Table of Contents

<b>INTRODUCTION.....</b>	<b>5</b>
Product Description .....	5
Item Checklist .....	5
Features & Specifications .....	6
Board Level Feature.....	7
Comprehensive Mainboard View .....	9
<b>INSTALLATION.....</b>	<b>10</b>
Installing the CPU .....	10
Setting the Jumpers .....	12
Connections.....	14
Installing the Memory (DIMM) .....	20
Installing an AGP Card .....	20
<b>MAINBOARD BIOS SETUP.....</b>	<b>21</b>
About the BIOS .....	21
Main Menu.....	22
Standard CMOS Setup.....	23
BIOS Features Setup.....	26
Chipset Features Setup .....	29
Power Management Setup .....	32
PNP/PCI Configuration Setup.....	34
Load BIOS Defaults.....	36
Load Setup Defaults.....	36
Integrated Peripherals Setup .....	37
Supervisor Password and User Password Setting.....	39
IDE HDD Auto Detection .....	40
Save & Exit Setup / Exit Without Saving.....	40

# TABLE OF CONTENTS

---

PCI Device Listing .....	40
<b>BUILT-IN SYMBIOS SCSI BIOS.....</b>	<b>41</b>
<b>FLASH BIOS PROGRAMMING UTILITY .....</b>	<b>47</b>
<b>DMI UTILITY.....</b>	<b>48</b>
<b>HARDWARE MONITORING UTILITY.....</b>	<b>49</b>
<b>DC-310U PCI ULTRA-SCSI ADAPTER.....</b>	<b>50</b>

---

# INTRODUCTION

## Product Description

The **P6B40D-A5** mainboard represents the highest level of technology available in PC Mainboards today. Designed as a flexible, high-performance and cost-effective solution for System Integrators and End Users alike, the P6B40D-A5 provides the power and expandability to meet the requirements of the most advanced operating systems and software applications.

The P6B40D-A5 features **dual** “SLOT 1” architecture, a modular design that supports dual Intel® Pentium® II processors (running at 233MHz ~ 333MHz with a 66MHz system bus and 350MHz ~ 450MHz on a 100MHz system bus) or single Celeron® processor. The ATX form factor design allows for more efficient system assembly with built-in mouse, serial and parallel port connectors. This eliminates the need for separate ribbon cable/connector brackets and speeds the manufacturing process.

The P6B40D-A5 is designed to provide greater overall system throughput by utilizing the latest in I/O technology. By incorporating such advanced features as Bus Mastering IDE and Universal Serial Bus (USB) onto the mainboard, optimum system performance is assured and system design and implementation is simplified.

Fully “Plug & Play” compatible via an Award BIOS, the P6B40D-A5 facilitates easy system configuration and peripheral setup. Advanced BIOS features include Intelligent Hardware Monitoring and Alert functions. The Award BIOS also supports ACPI readiness and is compatible with PC97 specification. With support for up to 1GB of System RAM (Type auto-detected by mainboard BIOS), 3.3V SDRAM, and 3.3V EDO, the P6B40D-A5 is the ideal foundation for high-end computer systems.

## Item Checklist

Your mainboard package should include the items listed below. Damaged or missing items should be reported to your vendor.

- |  |  |
|--|--|
| <input checked="" type="checkbox"/> The P6B40D-A5 mainboard  | <input type="checkbox"/> Optional CD-ROM containing Intel® LDCM and support software for updating the FLASH BIOS and IDE Drivers |
| <input checked="" type="checkbox"/> Floppy disk ribbon cable   | <input type="checkbox"/> Optional Thermal Sensor Cable   |
| <input checked="" type="checkbox"/> IDE ribbon cable   | <input type="checkbox"/> Optional I/O Shield   |
| <input checked="" type="checkbox"/> Diskette containing software for updating the FLASH BIOS and IDE drivers | <input type="checkbox"/> Optional Infrared Module  |
| <input checked="" type="checkbox"/> T510 GTL+ Bus Terminator   | <input type="checkbox"/> Optional AGP Graphic Card   |
| <input checked="" type="checkbox"/> This User’s Manual   | <input type="checkbox"/> Optional Celeron CPU Retention Kit:   |
| <input checked="" type="checkbox"/> Pentium II CPU Retention Kit:  | - Racks                   × 2  |
| - Rack with nuts           × 1   |  |
| - Washer with screws   × 2   |  |

# INTRODUCTION

---

## Features & Specifications

<b>Processor</b>	Dual SLOT 1 support dual Intel Pentium® II processors, 233~333 MHz (FSB 66MHz), 350~450 MHz (FSB 100MHz), or single Celeron® processor.
<b>Chipset</b>	Intel® 440BX AGPset
<b>BIOS</b>	Award® PCI BIOS, support ACPI, DMI, Green PC, Plug-and-Play, Boot from CD-ROM, SCSI, LS-120, and ZIP devices Symbios® SCSI BIOS
<b>System Memory</b>	4× 168-pin DIMM Sockets support up to 1 GB SDRAM memory capacity Support 8/16/32/64/128/256 MB Memory Module ECC supported
<b>On-board I/O Features</b>	1×Floppy Port (Up to 2.88MB) 1×Parallel Port (EPP, ECP Port) 2×Serial Ports (16550 Fast UART Compatible) 2×USB Ports 1×IrDA TX/RX Header 1×Wake-On-LAN Header
<b>Advanced Features</b>	Dual Slot 1 ready for Dual Pentium II processors CPU Fan, System Overheat and Voltage Hardware Monitoring Modem Ring-in Power on Soft Power Off
<b>PCI Bus Master IDE</b>	2×UltraDMA/33 IDE Ports support UltraDMA/33: 33MB/Sec.
<b>Expansion Slots</b>	1× 32-bit AGP slot 5× 32-bit PCI Bus Master slots 2× 16-bit ISA slots
<b>ATX Double Decker</b>	2×USB Ports 1×PS/2 Keyboard Port 1×PS/2 Mouse Port 1×Parallel Port 2×COM Ports
<b>ATX Power Connector</b>	3V, 5V and 12V 20-Pin ATX Power connector
<b>Switching VR</b>	Switching Voltage Regulator to support 1.3V to 3.5V
<b>Form Factor</b>	ATX Form factor 12" by 9.5" ( 305mm by 242mm )

## Board Level Feature

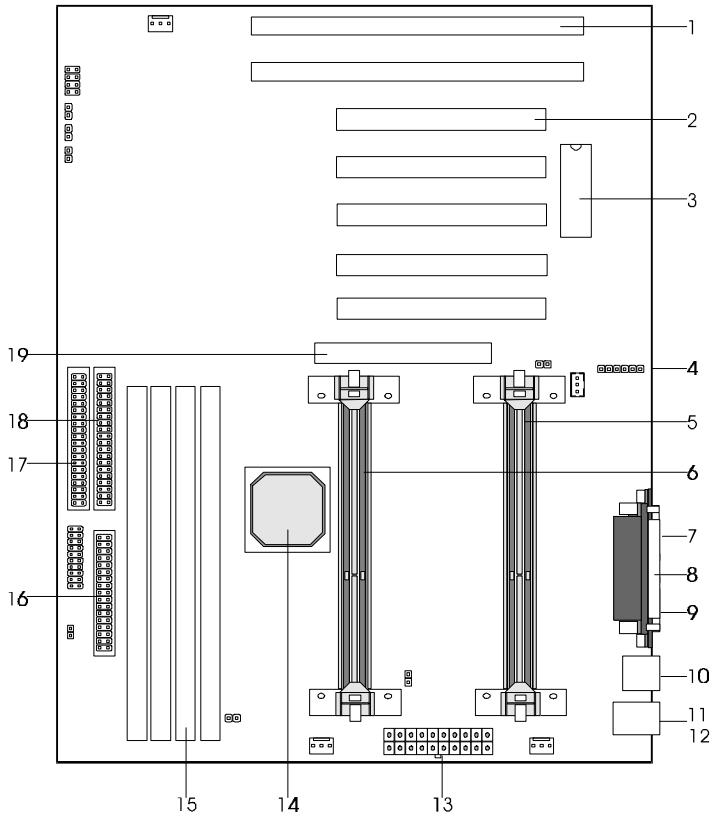

- |                            |                                      |
|----------------------------|--------------------------------------|
| 1. ISA slots               | 11. PS/2 mouse connector (top)       |
| 2. PCI slots               | 12. PS/2 keyboard connector (bottom) |
| 3. Mainboard BIOS          | 13. Power connector                  |
| 4. Infrared (IR) connector | 14. Intel® 440BX chipset             |
| 5. SLOT 1 (CPU1)           | 15. DIMM sockets                     |
| 6. SLOT 1 (CPU2)           | 16. Floppy connector                 |
| 7. COM2 connector          | 17. Primary IDE connector            |
| 8. Printer port connector  | 18. Secondary IDE connector          |
| 9. COM1 connector          | 19. AGP slot                         |
| 10. USB connectors         |                                      |

\* Board Size: ATX 305 mm x 242 mm (12" x 9.5")

# INTRODUCTION

---

1. **ISA SLOTS:** (2) 16-bit ISA slots.
2. **PCI SLOTS:** (5) 32-bit PCI slots are provided.
3. **MAINBOARD BIOS:** Award BIOS supporting “Plug and Play”, DMI, Green PC specification, on screen setup for Enhanced IDE and Multi-I/O. The BIOS is FLASH Upgradeable via the AWDFLASH Utility.
4. **INFRARED (IR) CONNECTOR:** UART2 can also be used for the optional Infrared Module, enabling wireless communication capability. A supplied bracket with a single customized cable connects directly to the infrared pin-header on the mainboard.
5. **SLOT 1 (CPU1):** First Slot 1 CPU socket for Pentium® II or Celeron® CPUs.
6. **SLOT 1 (CPU2):** Second Slot 1 CPU socket for the second Pentium® II CPU. In a single CPU system, this slot must be occupied by the T510 GTL+ Bus Terminator provided by the manufacturer.
7. **COM2 CONNECTOR:** High-speed UART compatible serial port. COM2 can be directed to the Infrared Module for wireless connection capability.
8. **PRINTER PORT CONNECTOR:** EPP and ECP compatible 25-pin D-Sub parallel port.
9. **COM1 CONNECTOR:** High-speed UART compatible serial port.
10. **USB CONNECTORS:** These connectors permit the connection of two USB peripheral devices directly to the port without an external hub. USB is a new technology supporting printers, fax modems and other telephony device.
11. **PS/2 MOUSE CONNECTOR:** Supports PS/2 style mice.
12. **PS/2 KEYBOARD CONNECTOR:** Supports PS/2 style keyboards.
13. **POWER CONNECTOR:** 20-Pin ATX Power Connector.
14. **INTEL® 440BX CHIPSET:** Features SDRAM, Ultra DMA/33 and AGP support.
15. **DRAM SOCKETS:** (4) 168-pin DIMM sockets are provided to support a maximum RAM memory capacity of 512 MB. DIMM types of 3.3-Volt true SDRAM is supported and automatically detected by the BIOS.
16. **FLOPPY CONNECTOR:** Built-in floppy controller supports (2) 5.25" or 3.5" (1.44MB or 2.88MB) floppy drives.
17. **PRIMARY IDE CONNECTOR:** Connector for first IDE channel. The on-board PCI Bus Mastering IDE controller features support for DMA Mode 2 and PIO Modes 3 and 4 for faster data transfer rates. (2) Connectors are provided for support of up to (4) IDE devices on two channels. ATAPI Tape Drives and CD-ROMs are also supported.
18. **SECONDARY IDE CONNECTOR:** Connector for second IDE channel.
19. **AGP SLOT:** AGP (Accelerated Graphics Port) is a new bus interface for high performance graphics capabilities, especially 3D.

## Comprehensive Mainboard View

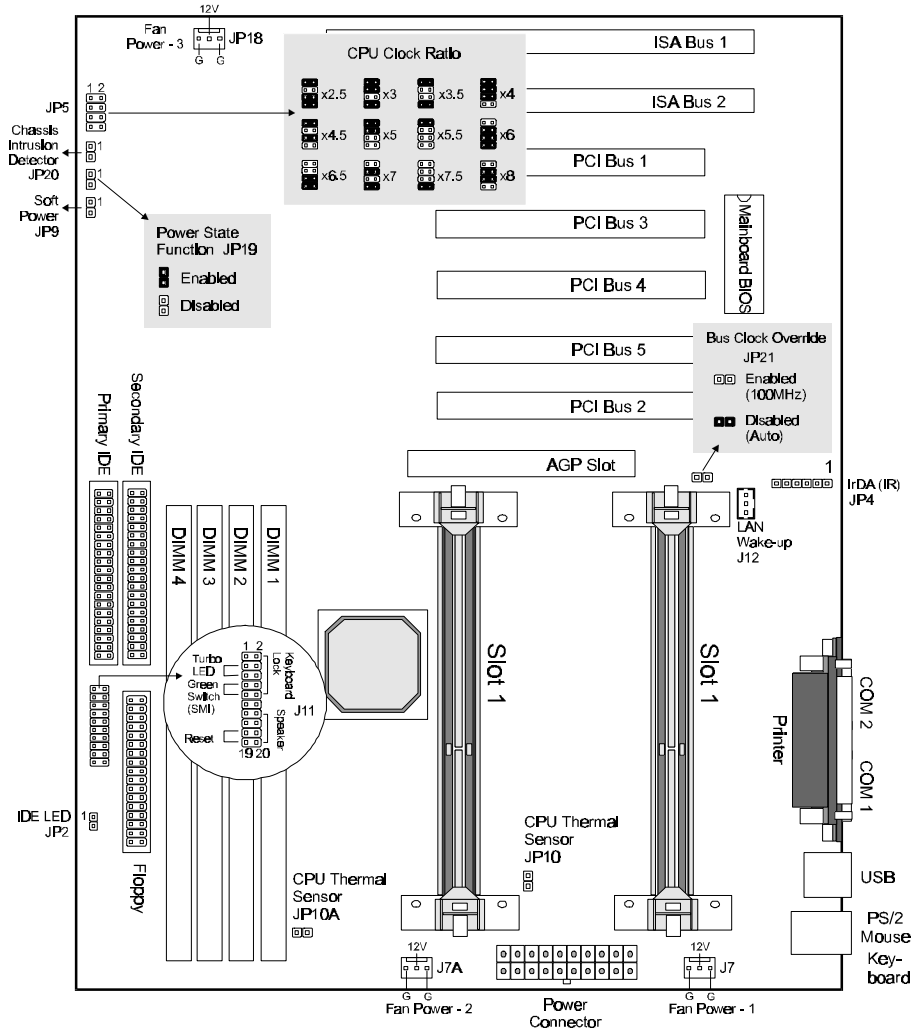

---

# INSTALLATION

## *Static Precautions*

Static electricity can be a serious danger to the electronic components on this mainboard. To avoid damage caused by electrostatic discharge, observe the following precautions:

- ✓ Don't remove the mainboard from its anti-static packaging until you are ready to install it into a computer case. Also, handle add-in cards and modules by the edges or mounting bracket.
- ✓ Before you handle the mainboard in any way, touch a grounded, anti-static surface, such as an unpainted portion of the system chassis, for a few seconds to discharge any built-up static electricity.

## Installing the CPU

Your **P6B40D-A5** mainboard features dual "SLOT 1" architecture, a design that can accommodate dual Intel® Pentium® II processors as well as single Celeron® processor. Before installing the CPU, attach the retention mechanism first.

### *Attaching the Retention Mechanism*

**For Pentium II CPUs:** Locate SLOT 1. Attach the Retention Mechanism as illustrated below. (Fig.1)

**For Celeron CPUs:** Locate SLOT 1. Push the Retention Mechanisms until they are firmly locked into place. (Fig.2)

\* Make sure all components are correctly oriented.

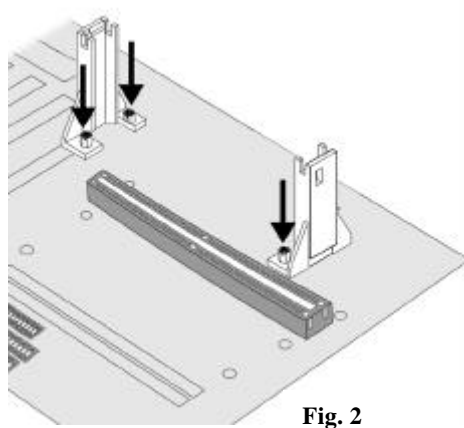
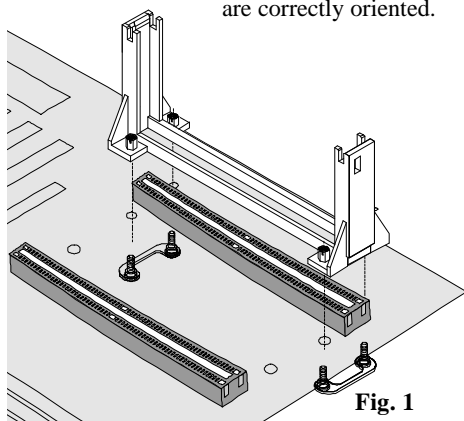

## Warning!

- ✓ **For a single CPU system:** You must insert the CPU into the **First Slot 1** socket and the *T510 GTL+ Bus Terminator* into the second Slot 1 socket.
- ✓ **For a dual CPU system:** You must use only **Pentium II CPUs** for the dual CPU system. **Do not use two Celeron CPUs.** It is recommended that you use two identical CPUs in your system. If you use CPUs with different speed requirements, you must set the CPU Clock Selection Jumper Block to the lower frequency.
- ✓ **CPU cooling fan:** It is required to use a CPU Cooling Fan to prevent the CPU from overheating. Install the fan first before inserting the CPU into the socket.

## Installing Pentium® II or Celeron® CPU

1. Slide the CPU down into the retention mechanism. Make sure the CPU is correctly oriented. (Fig. 1)
2. Seat the CPU firmly into the slot until the two tabs on the CPU click outwards to lock the CPU in place. (Fig. 2)

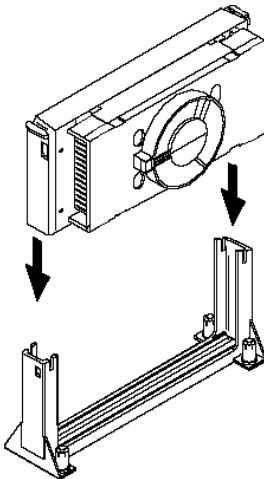

Fig. 1

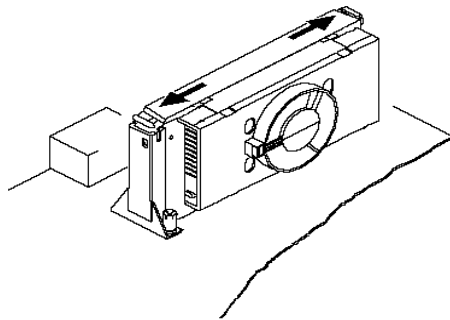
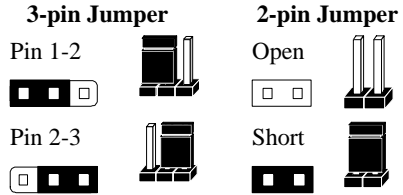

Fig. 2

# INSTALLATION

## Setting the Jumpers

Jumpers are used on this mainboard to select various settings and features. A 2-pin jumper has two settings: Open and Short (or Closed). The jumper is closed by placing the Jumper Cap across the two pins, thereby connecting them. 3-pin jumpers can be set to pins 1-2 or 2-3 connected. Pin-1 is labeled on the circuit board.



### Setting the CPU Clock Selection Jumper (JP5)

After installing the CPU, you must set the clock selection jumper to match the frequency of the CPU. Find the Jumper Block labeled JP5 on the mainboard. Set the jumper according to the table at right for the CPU frequency you are using.

The CPU Clock corresponds to the number marked on the CPU. The *Bus Clock* when multiplied with the *Ratio* gives the *CPU Clock*.

CPU Clock	Ratio	Bus Clock
233MHz	x3.5	66MHz
266MHz	x4.0	66MHz
300MHz	x4.5	66MHz
333MHz	x5.0	66MHz
366MHz	x5.5	66MHz
350MHz	x3.5	100MHz
400MHz	x4.0	100MHz
450MHz	x4.5	100MHz
500MHz	x5.0	100MHz
550MHz	x5.5	100MHz

- ✓ **For a dual CPU system:** It is recommended that you use two identical CPUs in your system. If your CPUs have different speed requirements, you must set the CPU Clock Selection Jumper Block to the lower frequency.
- If you are uncertain about the speed requirements of your particular CPU, you should obtain Technical Documentation from the manufacturer. Such information is available via the Intel WWW site.

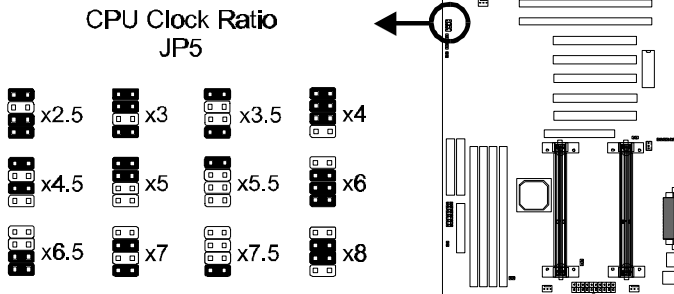

These jumpers automatically set the ISA Clock as well.

## *Setting the Bus Clock Override Jumper (JP21)*

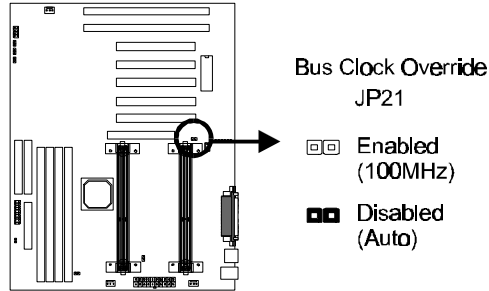

- *Intel 440BX chipset supports only 66/100 MHz bus clock. The 66.8 MHz bus clock can be extended to 68.5, 75 or 83.3 MHz, and the 100 MHz bus clock to 103, 112 or 133.3 MHz for internal test only (Please refer to **Chipset Features Setup** on page 29).*
- *Setting the Bus Clock Override Jumper to **Enabled** overrides the CPU's default Bus Clock and set it at 100 MHz.*
- *Over-clocking may cause serious system damage.*

# INSTALLATION

## Connections

### Cooling Fan (J7, J7A and JP18)

J7, J7A and JP18 are small 3-pin Header Connectors that provide 12-Volt power for CPU and chassis cooling fans. Plug in the fan cable to the connector. Pin-2 corresponds to the RED power lead as shown:

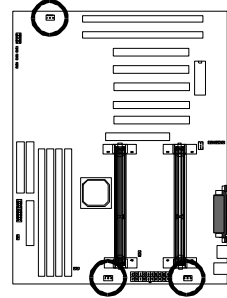
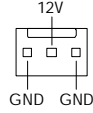

### CPU Thermal Sensor (JP10 and JP10A)

For the CPU Temperature Monitoring function to work properly, you must use the *optional CPU Cooling Fan* provided by the manufacturer. Hook the Thermal Sensor lead attached on the Fan to this connector, regardless of the polarity.

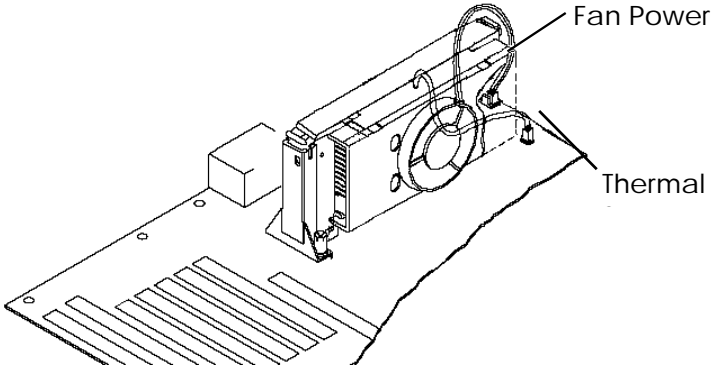
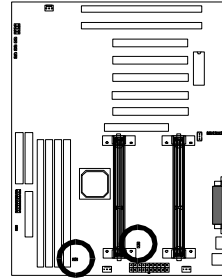

## Soft Power Switch (JP9)

Connects to the Power Switch featured on ATX case designs. This switch must be hooked up before the system can be powered on, unlike traditional “Baby-AT” designs where the power switch is located on the Power Supply itself.

**Note:** Under the following two conditions, you have to press and hold the switch for longer than 4 seconds to power off your system, regardless of the BIOS setting (Refer to page 32).

- Shortly after the system is powered on, when the BIOS message is not yet appear.
- When CPU hangs.

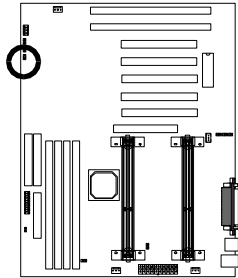

## IDE Activity LED (JP2)

Hook the IDE LED lead to this connector, with the RED lead corresponding to Pin-1.

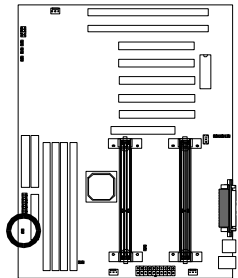

## Power Supply Connector

This mainboard features an ATX-style Power Supply Connector. This connector is keyed to prevent connection in the wrong direction. Line up the locking mechanism on the connector from the Power Supply with the tab on the mainboard connector. Press down until the two connectors are locked.

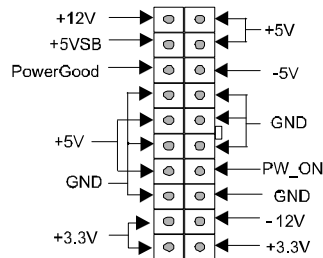
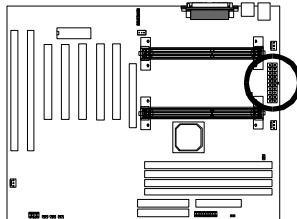

# INSTALLATION

## System Function Connector Block (J11)

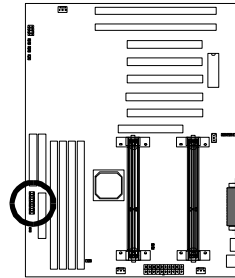
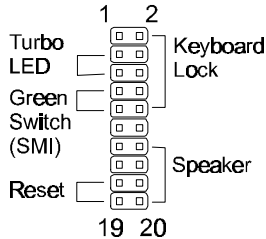

**Pins [3 & 5] Turbo LED switch** - The Turbo function is not supported by this mainboard. Therefore, the Turbo LED will always remain lit as long as the system power is on.

**Pins [7 & 9] SMI suspend switch lead** - If your system's case has a suspend switch, hook the lead from the switch to pins 7 & 9. A suspend switch is used to save electricity by putting the system into a suspend mode when the computer is not being used. This switch could also be used by the Turbo switch on the front of the system, since this mainboard does not support that function. For this switch to be functional, it must first be enabled in the Power Management Setup in the BIOS Setup utility.

**Pins [17 & 19] Reset switch lead** - Connects to the Reset Switch lead from the system's case. The reset switch is used to "cold-boot" the system without actually turning off the power, reducing wear and tear on the power supply.

**Pins [2, 6, 8, 10] Keyboard lock switch lead** - Pins 2 & 6 connect to the Power LED from the system's case. Pins 8 & 10 connect to the case-mounted keylock switch.

**Pins [14 & 20] Speaker connector** - Connects to the Speaker lead from the system's case.

## Serial and Parallel Ports

A 25-pin D-Sub header is provided on the back panel for a multi-mode bi-directional parallel port.

Two 9-pin D-Sub headers are also provided on the back panel for Serial ports.

### \* Modem Ring-In Power On

Install a modem (normally to COM2) and enable **Power On**

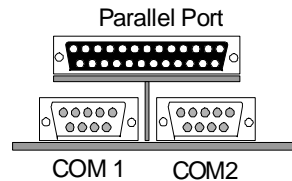

by **Ring/LAN** function from BIOS setup. (Please refer to page 32). This allows the modem to remotely power on the system.

## ***IrDA-Compliant Infrared Module Connector (JP4)***

The IrDA connector bracket hooks directly to this connector on the mainboard. This connector provides support for the optional wireless transmitting and receiving infrared module. You must first configure through the BIOS setup where UART2 is directed, COM2 or IrDA.

\* Pin 6 is reserved for consumer IR.

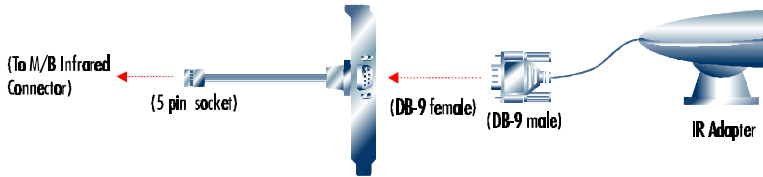
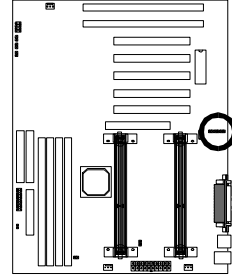

## ***Wake-up On LAN Connector (J12)***

The Wake-up On LAN function will allow the network to wake up a Soft Power Down (Soft-Off) PC. However, if your system is in the Suspend mode, you can wake-up the system only through an IRQ or DMA interrupt. To use the Wake-up On LAN function, you must enable the “**Power On by Ring/LAN**” field in the Power Management Setup of the Award BIOS. Connect the cable that comes with your LAN card to location J12 on the system board. Refer to the add-in card’s manual for details. Note: Your LAN card must support Magic Packet in order to use the Wake-up-On-LAN function.

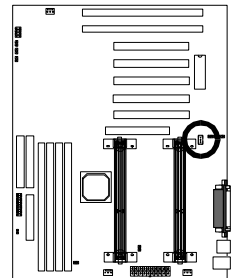



# INSTALLATION

---

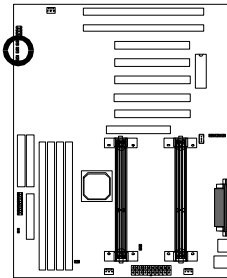
## *Power State Function (JP19)*



### Power State Function JP19

-  Enabled
-  Disabled

This feature will power on the PC when power returns after a power failure. Set JP19 to On (short) to enable this function.

“PWRON After PWR-Fail” in the Power Management Setup must be set accordingly. Refer to pages 31 and 32 for more information.

## *USB Connector*

This 8-pin connector permits connection of two USB peripheral devices directly to the system without an external hub.



## *PS/2 Keyboard and Mouse Connectors*

These two connectors are located on the back panel of the mainboard.

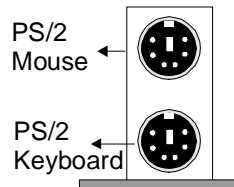

## *Floppy drives*

The on-board floppy controller supports (2) floppy disk drives with the floppy ribbon cable provided. Make sure the RED stripe on the ribbon cable is oriented towards Pin-1. Notice the “twist” between the sets of connectors on the floppy cable. The floppy drive “A” position is at the END of the cable, whereas floppy drive “B” is hooked to one of the connectors on the other side of the twist. The cable provides both “Edge” and “Pin” connectors for both the A and B positions to match the connector on your floppy drives.

## *IDE Hard Drives and CD-ROMs*

The on-board Enhanced IDE controller can support up to (4) IDE hard drives or other ATAPI devices, such as CD-ROMs. This controller, as with all Enhanced IDE controllers, consists of both **Primary** and **Secondary** ports. Each port has an associated connector and cable, which can support up to (2) ATAPI devices each.

All IDE devices have jumpers which allow the user to configure the device as either “Master” or “Slave”. A Master device is one that is **ALONE** on the IDE cable, whereas a Slave device is installed as a **SECOND** device on the same cable. Keep in mind that the Master device will appear *before* the Slave device in the CMOS Setup, as well as the Operating System software. *\*Refer to the device documentation for jumper settings.*

The Secondary IDE port can be used for up to (2) additional ATAPI devices. Normally it’s recommended that you connect your first hard drive to the Primary port, and the first CD-ROM to the Secondary.

Make sure to align the **RED** stripe on the ribbon cable with Pin-1 on the mainboard IDE connector. On most hard drives and CD-ROMs, the **RED** stripe should be oriented towards the power connector of the device.

## *Chassis Intrusion Detector (JP20)*

This lead works with specially designed chassis for monitoring the chassis to see if it has been opened.

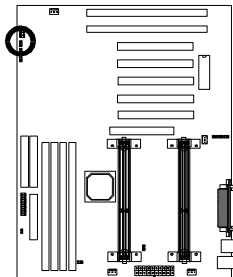

# INSTALLATION

## Installing the Memory (DIMM)

- The P6B40D-A5 mainboard has four sockets available for **168-pin DIMMs**. They must be 3.3 volt Unbuffered Synchronous DRAMs (SDRAM) or 3.3 volt EDO RAM.

### For using SDRAMs:

- *If you are using a CPU with a 100MHz system bus, you can use only the 100MHz (-10 ns) or faster SDRAMs.*
- *If you are using a CPU with a 66MHz system bus, you can use either the 66 MHz or 100MHz SDRAMs, or mix them both.*
- DIMM Sizes supported: **8MB, 16MB, 32MB, 64MB, 128MB, and 256MB**
- A total of **(4)** DIMMs can be installed for a maximum RAM capacity of **1 GB**.

To insert the DIMMs, the modules must be oriented in the correct way. Notice the notches of the DIMM. Align these notches as shown in the diagram below. Gently push the DIMM until the retainers on both sides of the socket lock the module in place. To remove a DIMM, push the retainers outward to release the module then pull the module out of the socket.

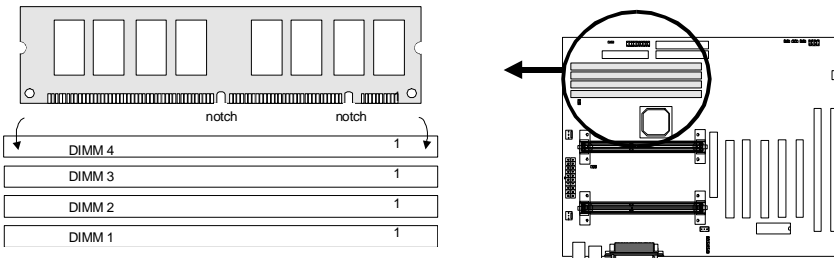

## Installing an AGP Card

This mainboard provides an AGP slot to support a new generation of graphics cards with high performance graphics capability.

**Note:** Make sure that the AGP card is firmly seated in the AGP slot. For the card that complies with the *AGP 1.x specifications*, a slightly more force may be required to fully insert the card into the slot. For cards that comply with AGP 2.0 and later specifications, the installation should be relatively easy.

---

# MAINBOARD BIOS SETUP

## About the BIOS

The **Mainboard BIOS** (Basic Input/Output System) acts as the bridge between your *Hardware* (CPU, Disk Drives, Video, etc.) and Operating System *Software* (Windows 95, OS/2 and so on...) The BIOS Setup (also called CMOS Setup) is where many hardware configuration options are set and stored. This configuration information will remain in the BIOS until it is changed, or cleared by removing the battery for a while then reinstalling it back.

CMOS (Complementary Metal Oxide Semiconductor) refers to the chip in which the BIOS information is stored.

The P6B40D-A5 mainboard features **Award BIOS**, which provides an easy to use Setup program to aid in hardware configuration. In this section we will look at the various menus and options contained in the Award BIOS Setup Program. This mainboard also features a “Flash” BIOS. A Flash BIOS can be upgraded via software, thereby eliminating the need to actually replace the “BIOS Chip” on the mainboard. Procedures for updating the BIOS follow this section.

The Award BIOS installed in your computer system’s ROM (Read Only Memory) is a custom version of an industry standard BIOS. This means that it supports Intel processor in a standard IBM-AT compatible input/output system.

### *Using Setup*

In general, you use the arrow keys to highlight items, press <Enter> to select, use the PageUp and PageDown keys to change entries, press <F1> for help and press <Esc> to quit.

### *Getting Help*

Pressing F1 will display a small help window that describes the appropriate keys to use and the possible selections for the highlighted item. To exit the Help Window press <Esc>.

### *A Final Note about Setup*

Not all systems have the same Setup. While the basic look and function of the Setup program remains the same for all systems, individual motherboard and chipset combinations require custom configurations. For example, you may find that your Setup main menu has a different number of entries from the main menu displayed in this manual. These are simply features not supported (or not user configurable) on your system.

The final appearance of the Setup program also depends on the Original Equipment Manufacturer (OEM) who built your system. If your OEM has decided that certain items should only be available to their technicians, those items may very well be removed from the Setup program.

# MAINBOARD BIOS SETUP

Shortly after the system is powered on, provided a CPU and sufficient RAM are installed, you will see the message: *Press DEL to enter SETUP.*

- Press the DEL key to enter the Award BIOS Setup program.

## Main Menu

Once you enter the Award BIOS CMOS Setup Utility, the Main Menu will appear on the screen. The Main Menu allows you to select from several setup functions and two exit choices. Use the arrow keys to select among the items and press <Enter> to accept and enter the sub-menu.

ROM PCI/ISA BIOS (xxxxxxx)  
CMOS SETUP UTILITY  
AWARD SOFTWARE, INC.

STANDARD CMOS SETUP	INTEGRATED PERIPHERALS
BIOS FEATURES SETUP	SUPERVISOR PASSWORD
CHIPSET FEATURES SETUP	USER PASSWORD
POWER MANAGEMENT SETUP	IDE HDD AUTO DETECTION
PNP / PCI CONFIGURATION	SAVE & EXIT SETUP
LOAD BIOS DEFAULTS	EXIT WITHOUT SAVING
LOAD SETUP DEFAULTS	
Esc : Quit	↑ ↓ → ← : Select Item
F10 : Save & Exit Setup	(Shift) F2 : Change Color
Time, Date, Hard Disk Type...	

Note that a brief description of each highlighted selection appears at the bottom of the screen.

# MAINBOARD BIOS SETUP

## Standard CMOS Setup

This first menu is where the most basic hardware options are set. Information regarding the system clock, IDE hard disks and floppy drives is stored and configured in this section. To enter the Standard CMOS Setup, press the [ENTER] key with this menu highlighted.

Upon entering the Standard CMOS Setup screen, you will see a screen like that below:

Date (mm:dd:yy) : Fri, Apr 7 1996									
Time (hh:mm:ss) : 00:00:00									
<u>HARD DISKS</u>	<u>TYPE</u>	<u>SIZE</u>	<u>CYLS</u>	<u>HEAD</u>	<u>PRECOMP</u>	<u>LANDZ</u>	<u>SECTOR</u>	<u>MODE</u>	
Primary Master	: Auto	0	0	0	0	0	0	Auto	
Primary Slave	: Auto	0	0	0	0	0	0	Auto	
Secondary Master	: Auto	0	0	0	0	0	0	Auto	
Secondary Slave	: Auto	0	0	0	0	0	0	Auto	
Drive A : 1.44M , 3.5in.									
Drive B : None									
Floppy 3 Mode Support: Disabled									
Video : EGA / VGA									
Halt On : All Errors									
					Base Memory : 640K				
					Extended Memory : 15360K				
					Other Memory : 384K				
					Total Memory : 16384K				
ESC : Quit			↑ ↓ → ← : Select Item			PU / PD / + / - : Modify			
F1 : Help			(Shift) F2 : Change Color						

First, let's set the system **Date**. Use the arrow keys to move to and highlight the "Date" option. Select the Month by using the PgDn and PgUp keys. This is how most settings will be configured. Then, move to the day, year and time via the arrow keys to finish setting the system date and time.

Keep in mind that the system time is set in 24-hour time. With this method, 1PM is represented as 13:00, 2PM as 14:00 and so on, with 00:00 corresponding to Midnight.

**Pri Master, Pri Slave, Sec Master, Sec Slave** - These four options relate to the (4) IDE hard drives, CD-ROMs or other ATAPI devices that can be controlled via the on-board IDE controller (review *IDE Hard Drives and CD-ROMs* on page 19). The "Pri Master" setting specifies the first device on the primary IDE channel, "Pri Slave" - the second. Sec Master and Sec Slave specify the devices on the secondary channel.

The first option available is the most important: **Type**. This is where you will specify the type of device and how it is represented in the BIOS Setup. If the device is a hard disk or CD-ROM, generally the *Auto* option is the best choice for fast and easy setup of the hard disk parameters. Let's take a look at the difference between the *Auto*, *User* and *Types (1-45)* options:

## MAINBOARD BIOS SETUP

---

- **Auto** - This option instructs the BIOS to automatically configure the hard disk by reading the parameters (cylinders, sectors, etc.) directly from the hard disk's firmware. Use this option if you are configuring a new hard drive, or one that has already been formatted using the *Auto* option. Keep in mind that a hard drive is configured using a certain set of parameters, those same parameters must be used for the life of the drive, unless the drive is re-FDISKed using a different parameter set. (This procedure deletes the old partition(s) on the drive and creates a new one, using the new parameters).
- **User** - This option allows you to manually enter in the parameters of the hard drive. Generally, this option would be used only if the hard drive has already been formatted with a certain set of parameters, and assured consistency between the old and new parameters is desired.

TYPE	drive type
CYLS.	number of cylinders
HEADS	number of heads
PRECOMP	write precom
LANDZONE	landing zone
SECTORS	number of sectors
MODE	mode type
- **Types 1-45** - Similar to the *User* option, these types should only be used if the exact parameters for the hard drive are already entered as a specific type stored in the Setup Program. Again, this would only be needed to assure that the parameters the drive was formatted with and those it is using now, are identical. For new hard drives, the *Auto* option is the preferred choice.

**Mode** - One of Enhanced IDE's most important features is LBA (Logical Block Addressing) Mode. This feature allows the use of larger hard drives by providing a way to bypass the cylinder limitations imposed by many Operating Systems. LBA Mode is used to extend a hard drive's useable capacity by "remapping" the cylinders in a way that is acceptable to these operating systems. For instance, a hard drive with the parameters of 2100 Cylinders, 16 Heads and 63 Sectors would be represented by LBA Mode as 525 Cylinders, 64 Heads and 63 Sectors. (Notice that the Cylinders have been divided, and the Heads have been multiplied, by a factor of 4)

On hard drives smaller in capacity than 528MB, LBA support is not needed. The option on these devices is ignored, even if enabled. For hard drives greater than 528MB, LBA mode should be enabled. The following rules apply:

- Operating Systems that do not use the FAT file system do not need LBA Mode, and can use the Normal or Large Modes. Examples would be NetWare and Unix.
- When configuring a new hard drive greater than 528MB in capacity, always make sure LBA mode is enabled.
- If you are using a hard drive that is over 528MB in capacity, but was already formatted without using LBA mode, LBA support will be ignored even if it is enabled. This assures correct access to the drive's data.
- **SCSI Hard Drives** are NOT entered into the Mainboard BIOS Setup in any way. The hard drive settings in the Standard CMOS Setup are only for drives connected to the

## MAINBOARD BIOS SETUP

IDE Controller. So, if only SCSI drives were installed, all these settings would be set to **Type: None**. SCSI Devices are configured via the SCSI controller's BIOS.

**Floppy Drives A: and B:** - Select the Type for the A: and/or B: floppy drives. Remember, floppy drive A: is the first drive, hooked to the END of the floppy ribbon cable. Floppy drive B: is hooked up after the twist. Available settings are listed below:

None	No floppy drive installed
360K, 5.25 in	5-1/4 inch PC-type standard drive; 360 kilobyte capacity
1.2M, 5.25 in	5-1/4 inch AT-type high-density drive; 1.2 megabyte capacity
720K, 3.5 in	3-1/2 inch double-sided drive; 720 kilobyte capacity
1.44M, 3.5 in	3-1/2 inch double-sided drive; 1.44 megabyte capacity
2.88M, 3.5 in	3-1/2 inch double-sided drive; 2.88 megabyte capacity

**Floppy 3 Mode Support:** - Enable this option ONLY for floppy drive(s) that support the Japanese standard (1.2MB on 3.5" Diskette). Options: Disabled (Default), Both, Drive A / B.

**Video** - This category selects the type of video adapter used for the primary system monitor. Although secondary monitors are supported, you do not have to select their type in Setup.

EGA/VGA	Enhanced Graphics Adapter/Video Graphics Array. For EGA, VGA, SEGA, SVGA or PGA monitor adapters.
CGA 40	Color Graphics Adapter, power up in 40 column mode
CGA 80	Color Graphics Adapter, power up in 80 column mode
MONO	Monochrome adapter, includes high resolution monochrome adapters

**Halt On** - Determines whether or not the system will prompt you if an error is detected during POST.

No Errors	The system boot will not be stopped for any error that may be detected.
All Errors	Whenever the BIOS detects a non-fatal error the system will be stopped and you will be prompted.
All, But Keyboard	The system boot will not stop for a keyboard error; it will stop for all other errors.
All, But Diskette	The system boot will not stop for a disk error; it will stop for all other errors.
All, But Disk/Key	The system boot will not stop for a keyboard or disk error; it will stop for all other errors.

**Memory** - This category is display only. All memory detected by the POST (Power On Self Test) of the BIOS is shown as the following types:

**Base Memory** is the amount of conventional memory installed in the system. This value is typically 640K for systems with 640K or more memory installed on the motherboard. The **Extended Memory** is the amount of memory located above 1MB in the CPU's memory address map. **Other Memory** refers to the memory located in the region between 640K and 1MB. This region can be used for *shadowing* as well as *expanded memory* in DOS.

# MAINBOARD BIOS SETUP

## BIOS Features Setup

This menu provides access to more advanced BIOS configuration settings that deal with overall performance of the system and peripheral setup. This section allows you to configure your system for basic operation. You have the opportunity to select the system's default speed, boot-up sequence, keyboard operation, shadowing and security.

Virus Warning	: Disabled	OS Select For DRAM > 64MB	: Non-OS2
CPU Internal Cache	: Enabled	HDD S.M.A.R.T. Capability	: Disabled
External Cache	: Enabled	Report No FDD For WIN 95	: No
CPU L2 Cache ECC Checking	: Enabled	Video BIOS Shadow	: Enabled
Quick Power On Self Test	: Enabled	C8000-CBFFF Shadow	: Disabled
Hard Disk Boot From	: Pri-IDE-M	CC000-CFFFF Shadow	: Disabled
Boot Sequence	: C, A	D0000-D3FFF Shadow	: Disabled
Swap Floppy Drive	: Disabled	D4000-D7FFF Shadow	: Disabled
Boot Up Floppy Seek	: Disabled	D8000-DBFFF Shadow	: Disabled
Boot Up NumLock Status	: On	DC000-DFFFF Shadow	: Disabled
Typematic Rate Setting	: Disabled	ESC : Quit	↑ ↓ → ← : Select Item
Typematic Rate (Chars/Sec)	: 6	F1 : Help	PU/PD/+/- : Modify
Typematic Delay (Msec)	: 250	F5 : Old Values	(Shift) F2 : Color
Security Option	: System	F6 : Load BIOS Defaults	
PCI / VGA Palette Snoop	: Disabled	F7 : Load Setup Defaults	
Assign IRQ For VGA	: Enabled		
MPS Version Control For OS	: 1.4		

**Virus Warning** - When enabled, the BIOS will warn the user when any program attempts to write to or format the boot sector. If an attempt is made, the BIOS will halt the system and the following error message will appear:

<p><b>! WARNING !</b>            Disk boot sector is to be modified            Type "Y" to accept write or "N" to abort write            Award Software, Inc.</p>
---

You can accept or abort this operation.

**Note:** This feature is designed to guard against viruses that modify the boot sector on hard disks. However, many disk diagnostic programs that attempt to access the boot sector table, as well as partition and format programs, will also trigger this warning. If you will be running such a program, you can disable Virus Protection first, or choose "Y" to accept the boot sector modification when this message shows up.

**CPU Internal Cache** - Enables or Disables the Level-1 Internal Cache memory. Generally, this would only be *Disabled* for troubleshooting purposes.

## MAINBOARD BIOS SETUP

---

**External Cache** - Enables or Disables the Level-2 External Cache memory. Generally, this would only be *Disabled* for troubleshooting purposes.

**CPU L2 Cache ECC Checking** - Enables or Disables *ECC* (Error Checking and Correcting) for the CPU's Level 2 built-in cache.

**Quick Power on Self Test** - Speeds up Power On Self Test (POST) after the computer is powered on. When set to *Enabled*, the BIOS will shorten or skip some checks during POST.

**Hard Disk Boot From** - This option lets you choose to boot from Primary IDE Master (Pri-IDE-M), Primary IDE Slave (Pri-IDE-S), Secondary IDE Master (Sec-IDE-M), Secondary IDE Slave (Sec-IDE-S), or SCSI hard disk. Same as IDE options, the **Boot Sequence** in the next field is set to *C, A* when the *SCSI* is chosen.

**Boot Sequence** - When your system is powered on, the BIOS performs a variety of operations, then attempts to boot an Operating System from either a hard drive, floppy drive, CD-ROM or LS-120/ZIP. This setting determines the sequence that the BIOS will follow when searching devices for a bootable disk. Most users find the *C, A* setting to be most beneficial, since it takes the least amount of time to boot the system. If however, you want the ability to boot from a Floppy or CD-ROM drive, you would need to choose either the *A, C* or *CDROM, C, A* setting. For instance, if your boot sequence was set to *C, A* and for some reason you wanted to boot to your Floppy A: Drive, it would not be possible, since the BIOS would always boot from the C: drive first. In this case, this setting would need to be changed to *A, C* so that the system would first check the floppy drive for a bootable disk. This would slow bootup speed, however, since the floppy would be checked on every boot.

A,C	System will first search for boot sector on floppy disk, then hard disk.
C, A	System will first search hard disk drive then floppy disk drive for boot sector.
C, CDROM, A	System will first search for boot sector on hard disk drive, then CDROM drive, and then floppy disk drive.
CDROM, C, A	System will first search the CDROM drive, then hard disk drive and then floppy disk drive for boot sector.
C only	System will search for boot sector on hard disk drive only.
LS/ZIP, C	System will first search for boot sector on LS-120 IDE floppy drive or ZIP ATAPI drive, then hard disk.

**Swap Floppy Drive** - The hardware connections determine which floppy is configured as drive A: and drive B: "Swapping" the floppy drives can be useful if your system has two floppy drives, and you want the ability to boot from both. For example: Since a PC cannot boot from the B: Floppy, you would need to "Swap" floppy drives A: and B: in order to set the second floppy drive to drive A:, thereby making it bootable.

**Boot Up Floppy Seek** - When enabled, BIOS will attempt to move the head of the floppy disk drive forth and back once during POST to see if the drive is working properly.

# MAINBOARD BIOS SETUP

---

**Boot Up NumLock Status** - When *On*, the NumLock key will be automatically enabled when the system boots.

**Typematic Rate Setting** - Determines if the typematic rate is to be used. When disabled, continually holding down a key on your keyboard will generate only one instance. In other words, the BIOS will only report that the key is down. When the typematic rate is enabled, the BIOS will report as before, but it will then wait a moment, and, if the key is still down, it will begin to report that the key has been depressed repeatedly. This feature is used to accelerate cursor movements with the arrow keys.

**Typematic Rate (Chars/Sec)** - When the typematic rate is enabled, this selection allows you to select the rate at which the keys are accelerated: Options are 6 (default), 8, 10, 12, 15, 20, 24 and 30.

**Typematic Delay (Msec)** - When the typematic rate is enabled, this selection allows you to select the delay (in msec) between when the key was first depressed and when the acceleration begins. Options are 250 (default), 500, 750 and 1000.

**Security Option** - This option enables password checking every time the computer is powered on *or* every time BIOS Setup is executed. If *System* is chosen, a user password prompt appears every time the computer is turned on. If *Setup* is chosen, the password prompt appears only when the BIOS Setup program is executed. Refer to the section *Supervisor Password* for more information.

**PCI / VGA Palette Snoop** - This option must be set to *Enabled* if any ISA MPEG card installed requires VGA palette snooping. The settings are *Disabled* or *Enabled*.

**Assign IRQ For VGA** - The *Enabled* option allows the BIOS to auto-route an IRQ for use by a VGA card. While most of the VGA cards do not need an IRQ assignment, certain VGA cards may need it.

**MPS Version Control For OS** - Normally your OS should support **Multiple Processor Specifications** version 1.4. If your OS only support version 1.1, set this option to 1.1.

**OS Select For DRAM > 64MB** - This should be set to **OS2** if you are running IBM OS/2 with more than 64MB of RAM in the system. Otherwise, the setting should be **Non-OS2**.

**HDD S.M.A.R.T. Capability** - The default is *Disabled*. If you are using hard drives that support S.M.A.R.T., set this field to *Enabled*. SMART (Self-Monitoring, Analysis and Reporting Technology) is a reliability prediction technology for ATA/IDE and SCSI drives. The drive will provide sufficient notice to the system or user to backup data prior to the drive's failure. SMART is supported in ATA-3 or later hard drives.

**Report No FDD For WIN95** - While the FDD in "STANDARD CMOS SETUP" is set to NONE, set this option to *No* to release IRQ6 for passing Win95 logo. This option is irrelevant under normal operation.

## MAINBOARD BIOS SETUP

**Video BIOS Shadow** - This option controls the location of the contents of the 32KB of Video ROM beginning at the C0000h memory location. The settings are:

Enabled	The contents of C0000h-C7FFFh are written to the same address in system memory (RAM) for faster execution.
Disabled	The video ROM is not copied to RAM. The contents of the video ROM cannot be read from or written to cache memory.

**C8000-DFFFF Shadow** - These options control the location of the contents of the 16KB expansion card ROMs beginning at the specified memory location. If no adapter ROM is using the named ROM area, this area is made available to the local bus. Shadowing a ROM reduces the memory available between 640KB and 1024KB by the amount used for this purpose. The settings are *Enabled* or *Disabled*.

### Chipset Features Setup

This setup menu contains advanced configuration options relating to the mainboard chipset. These options are rarely changed by the user.

SDRAM CAS latency Time	: 3	Current CPU1 Temp.	: 47°C/116°F
DRAM Data Integrity Mode	: Non-ECC	Current CPU2 Temp.	: 47°C/116°F
System BIOS Cacheable	: Enabled	Current System Temp.	: 35°C/95°F
Video RAM Cacheable	: Enabled	Current CPU1 Fan Speed	: 5400 RPM
8 Bit I/O Recovery Time	: 1	Current CPU2 Fan Speed	: 5400 RPM
16 Bit I/O Recovery Time	: 1	Current Chassis Fan Speed	: 0 RPM
Memory Hole At 15M-16M	: Disabled	V5.0	: 5.14V
Passive Release	: Enabled	V-5.0	: -5.04V
Delayed Transaction	: Enabled	V12.0	: 12.16V
AGP Aperture Size (MB)	: 64	V-12.0	: -12.35V
		V3.3	: 3.36V
		VCore	: 2.81V
		CPU1 Warning Temp.	: Disabled
		System Warning Temp.	: Disabled
		CPUFAN Warning Speed	: Disabled
		Auto Disable Unused Clock	: Disabled
		Ext. Clock Frequency	: 68.5/103Mhz
		ESC : Quit      ↑ ↓ → ← : Select Item	
		F1 : Help      PU/PD/+/- : Modify	
		F5 : Old Values (Shift) F2 : Color	
		F6 : Load BIOS Defaults	
		F7 : Load Setup Defaults	

**SDRAM CAS Latency Time** - This item allows you to select the CAS# latency for all SDRAM cycles. Options are 3 or 2 Clocks. \*Default = 3 Clocks.

## MAINBOARD BIOS SETUP

---

**DRAM Data Integrity Mode** - When set at *Non-ECC* (default), there will be no memory errors shown on the monitor for **Memory parity SERR# (NMI)**. When parity DRAM modules are used, select *ECC* (Error Checking and Correcting) to correct 1-bit memory errors in the memory.

**System BIOS Cacheable** - When *Enabled*, the contents of the F0000h system memory segment can be cached to the Level-2 cache memory. The contents of the F0000h memory segment are always copied from the BIOS ROM to system RAM for faster execution and PCI compliance.

**Video RAM Cacheable** - *Enabled* will cause access to the video RAM addressed at B0000H to BFFFH to be cacheable and also let the A0000H to AFFFFH to be a UC memory type.

**8 Bit I/O Recovery Time** - The recovery time is the length of time, measured in ISA BUS clocks, that the system will delay after the completion of an input/output request. This delay takes place because the CPU is operating faster than the input/output bus. Therefore the CPU must be delayed to allow for the completion of I/O transfers. This item allows you to determine the recovery time allowed for 8 bit I/O. Choices are from NA, 1 to 8 ISA BUS clocks. *\*1* is the default.

**16 Bit I/O Recovery Time** - This item allows you to determine the recovery time allowed for 16 bit I/O. Choices are from NA, 1 to 4 ISA BUS clocks. *\*1* is the default.

**Memory Hole At 15M-16M** - In order to improve compatibility, certain space in memory can be reserved for old style ISA cards that map memory between 15M-16M. Do not enable this feature unless you use the old style ISA card, otherwise the memory size may be reduced to 15 MB for some O.S. *\*Disabled* is the default.

**Passive Release** - The PIIX4 provides a programmable Passive Release mechanism to meet the required master latencies. When *enabled* (default), ISA masters may see long delays in access to any PCI memory, including the main DRAM array.

**Delayed Transaction** - When enabled, the delay transaction mechanism will be in effect when PIIX4 is the target of a PCI transaction.

**AGP Aperture Size (MB)** - Select the size of the Accelerated Graphics Port (AGP) aperture. The aperture is a portion of the PCI memory address range dedicated for graphics memory address space. Host cycles that hit the aperture range are forwarded to the AGP without any translation. See [www.agpforum.org](http://www.agpforum.org) for AGP information. Options are 4, 8, 16, 32, 64 (default), 128 and 256 MB.

**System Hardware Monitor** - The onboard hardware monitor allows you to observe the current temperatures of the CPU(s) and system, current speeds (in RPM, rotation per minute) of the CPU fan(s) and chassis fan, as well as the various operating voltages. (If the fan is not installed, 0 RPM will be shown.)

## MAINBOARD BIOS SETUP

---

**CPU1 Warning Temp.** - Once the temperature of CPU1 exceeds the temperature specified, a warning will be issued via the speaker and the operating speed of CPU1 will be slowed down to ease the situation. Options are Disabled, 50°C/122°F - 80°C/176°F (in every 5°C interval). \* *This option is not available for CPU2.*

**System Warning Temp.** - Once the system temperature exceeds the temperature specified, a warning will be issued via the speaker. Options are Disabled, 40°C/104°F, 45°C/113°F, and 50°C/122°F.

**CPUFAN Warning Speed** - Once the speed of the CPU cooling fan falls below the speed specified (in RPM, rotation per minute), a warning will be issued via the speaker. Options are Disabled, 3000, 3500, 4000 RPM.

**Auto Disable Unused Clock** - When enabled, any clock not in use will be disabled to reduce EMI radiation.

**Ext. Clock Frequency** - Intel 440BX chipset supports only the 66.8/100 MHz bus clock. With this option, the bus clock can be extended from 66.8 MHz to 68.5, 75 or 83.3 MHz, or from 100 MHz to 103, 112 or 133.3 MHz for internal test only. *Over-clocking may cause serious system damage.*

# MAINBOARD BIOS SETUP

## Power Management Setup

This menu contains configuration options that reduce power consumption when the system is not in use. Other “Green-PC” compliant peripherals are also supported. Power Management allows you to configure you system to use energy most efficiently, and yet still in a manner consistent with your own style of computer use.

Power Management	: User Defined	** Reload Global Timer Events **
PM Control by APM	: Yes	IRQ[3-7, 9-15], NMI
Video Off Method	: DPMS	Primary IDE 0
Video Off After	: Doze	Primary IDE 1
MODEM Use IRQ	: 3	Secondary IDE 0
		Secondary IDE 1
Doze Mode	: Disabled	Floppy Disk
Standby Mode	: Disabled	Serial Port
Suspend Mode	: Disabled	Parallel Port
HDD Power Down	: Disabled	
Throttle Duty Cycle	: 62.5%	
VGA Active Monitor	: Enabled	
Soft-Off by PWR-BTTN	: Instant-Off	
PWRON After PWR-Fail	: On	
Power On by Ring/LAN	: Disabled	ESC : Quit      ↑ ↓ → ←: Select Item
Power On by Alarm	: Disabled	F1 : Help      PU/PD/+/- : Modify
		F5 : Old Values (Shift) F2 : Color
		F6 : Load BIOS Defaults
		F7 : Load Setup Defaults
IRQ 8 Break suspend	: Disabled	

**Power Management** - This category allows you to select the type (or degree) of power saving and is directly related to the following modes: Doze Mode, Standby Mode, Suspend Mode and HDD Power Down. There are four selections for Power Management, three of which have fixed mode settings:

Disabled	No power management. Disables all four modes
Min Saving	Minimum power management. Doze Mode = 1 hr. Standby Mode = 1 hr., Suspend Mode = 1 hr., and HDD Power Down = 15 min.
Max Saving	Maximum power management -- <b>ONLY AVAILABLE FOR SL CPUs.</b> Doze Mode = 1 min., Standby Mode = 1 min., Suspend Mode = 1 min., and HDD Power Down = 1 min.
User Defined (default)	Set each mode individually. When Enabled, each range is from 1 min. to 1 hr., except for HDD Power Down which ranges from 1 min. to 15 min.

**PM Control by APM** - When set to Yes, an Advanced Power Management device will be activated to enhance the Max. Power Saving mode and stop the CPU internal clock. If the Max. Power Saving is not enabled, this will be preset to *No*.

**Video Off Method** - This determines the manner in which the monitor is blanked.

## MAINBOARD BIOS SETUP

V/H SYNC+Blank	This selection will cause the system to turn off the vertical and horizontal synchronization ports, writing blanks to the video buffer.
Blank Screen	This option only writes blanks to the video buffer.
DPMS	Initial display power management signaling.

**Video Off After** - This is to determine when to activate the video off function. Options are: “Standby”, “Doze” (default), “Suspend” and “N/A”.

**MODEM Use IRQ** - This item tells the Power Management BIOS which IRQ is assigned to the installed MODEM. Options are NA, 3 (default), 4, 5, 7, 9, 10, and 11.

**Doze/Standby/Suspend/HDD Power Down** - These four modes are Green PC power saving functions which are only user configurable when *User Defined* Power Management has been selected. See below for available selections.

<b>Doze Mode</b>	When enabled and after the set time of system inactivity, the CPU clock will run at slower speed while all other devices still operate at full speed.
<b>Standby Mode</b>	When enabled and after the set time of system inactivity, the fixed disk drive and the video will be shut off while all other devices still operate at full speed.
<b>Suspend Mode</b>	When enabled and after the set time of system inactivity, all devices except the CPU will be shut off.
<b>HDD Power Down</b>	When enabled and after the set time of system inactivity, the hard disk drive will spin down while all other devices remain active.

**Throttle Duty Cycle** - This item determines the duty cycle for the clock control thermal throttling mode. The duty cycle indicates the percentage of time the STPCLK# signal is asserted.

**VGA Active Monitor** - When enabled, the video detect logic will generate a timer reload event for device monitor 11.

**Soft-Off by PWR-BTTN** - With *Instant-Off* selected, the ATX switch functions like a normal system power off button. With *Delay 4 Sec.* selected, you must hold down the ATX switch for more than 4 seconds to power off the system.

**PWRON after PWR-Fail** – This feature will power-on the PC when power returns after a power failure. The table on the next page lists the options available and the corresponding “System State” when power returns.

# MAINBOARD BIOS SETUP

---

Options Available	System State When Power Failure Occurred	System State When Power Returns
Former-State	On	On
	Off	Off
Off	On	Off
	Off	Off
On	On	On
	Off	On

**Power On by Ring/LAN** – An input signal on the serial Ring Indicator (RI) line (in other words, an incoming call on the modem) will power on the system. With a LAN card installed, the Wake-up On LAN function allows the network to wake up a Soft Power Down (Soft-Off) PC. Refer to “Wake-up On LAN Connector” on page 17 for more information.

**Power On by Alarm** - When enabled, the system will automatically power on at the time and date of the month (0 for daily) specified.

**IRQ 8 Break Suspend** - When *IRQ 8 Clock Event* is enabled, the unmasked IRQ8 will generate a Fast Burst Timer reload or stop break event.

**\*\* Reload Global Timer Events \*\***

IRQ[3-7, 9-15], NMI: Enable an unmasked IRQ [3-7, 9-15], NMI, when asserted, reload the Global Standby Timer.

Primary/Secondary IDE 0/1, Floppy Disk, Serial Port, Parallel Port: Enable reload events from the respective device monitor to reload the Global Standby Timer.

## PNP/PCI Configuration Setup

The PCI Personal Component Interconnect Bus was developed by Intel and other industry leader partners primarily to address two important issues faced by PC hardware designers today: a) How to allow peripheral devices to take the fullest advantage of the power of Pentium and Pentium Pro chip technology, and b) Provide a simpler installation process for peripheral devices, such as Network cards, EIDE or SCSI controllers.

PCI accomplishes these goals with its 32-bit Data path Local Bus design, and support for Plug & Play. Unlike older expansion bus architectures, PCI provides peripherals with a direct connection to the CPU and memory. The PCI bus runs at 33Mhz and has a maximum transfer capability of 132MBps. With Plug & Play, the system BIOS automatically determines hardware resources for new peripherals, simplifying installation of multiple interface cards.

## MAINBOARD BIOS SETUP

This Setup Menu provides configuration options for the PCI Bus and its assigned resources.

PNP OS Installed : No Resources Controlled by : Manual Reset Configuration Data : Enabled  IRQ-3 assigned to : PCI/ISA PnP IRQ-4 assigned to : PCI/ISA PnP IRQ-5 assigned to : PCI/ISA PnP IRQ-7 assigned to : PCI/ISA PnP IRQ-9 assigned to : PCI/ISA PnP IRQ-10 assigned to : PCI/ISA PnP IRQ-11 assigned to : PCI/ISA PnP IRQ-12 assigned to : PCI/ISA PnP IRQ-14 assigned to : PCI/ISA PnP IRQ-15 assigned to : PCI/ISA PnP DMA-0 assigned to : PCI/ISA PnP DMA-1 assigned to : PCI/ISA PnP DMA-3 assigned to : PCI/ISA PnP DMA-5 assigned to : PCI/ISA PnP DMA-6 assigned to : PCI/ISA PnP DMA-7 assigned to : PCI/ISA PnP	Used MEM base addr : N/A  Assign IRQ for USB : Enabled SYMBIOS SCSI BIOS : Auto PCI Latency Timer : 80 PCI Clocks  ESC : Quit    ↑ ↓ → ← : Select Item F1 : Help    PU/PD/+/- : Modify F5 : Old Values (Shift) F2 : Color F6 : Load BIOS Defaults F7 : Load Setup Defaults
--	--

**PNP OS Installed** - Set to Yes if your operating system supports Plug & Play, such as Windows® 95.

**Resources Controlled By** - The Award Plug and Play BIOS has the capacity to automatically configure all of the boot and Plug and Play compatible devices. This capability is specifically designed for a Plug and Play operating system such as Windows® 95. Choices are *Auto* and *Manual* (default).

**Reset Configuration Data** - Reset Configuration Data: When set to Enabled, ESCD (Extended System Configuration Data) is cleared. This setting will automatically be set back to Disabled when the system reboots. *Enabled* (default) and *Disabled*.

**IRQ3/4/5/7/9/10/11/12/14/15, DMA0/1/3/5/6/7 assigned to** - By default, all resources are assigned to the PCI Bus. If an ISA card requires a particular IRQ or DMA channel, those resources should be set to Legacy ISA so that the PCI Bus will not try to use them. Choices are *Legacy ISA* and *PCI/ISA PnP*.

**Assign IRQ For USB** - When Enabled, the system automatically assigns an IRQ for the USB device connected to your system. However, if you are not using USB devices and an ISA slot requires an IRQ address, set this function to Disabled. The IRQ address previously occupied by the USB device will be available for the ISA slot.

**Used MEM base address** - This item allows you to determine which basic addresses are not to be occupied by PCI Card and leave these addresses for some special ISA Card used only.

## MAINBOARD BIOS SETUP

---

Choices are C800, CC00, D000, D400, D800, DC00.

**Used MEM length** - Select a length for the memory area specified in the previous field. This field does not appear if no base address is specified. Options are 8K, 16K, 32K, 64K.

**SYMBIOS SCSI BIOS** - When set to *Auto* (Default), the system will automatically sense the presence of any SCSI adapter that uses a Symbios SYM53C8XX SCSI chip:

If the SCSI adapter installed <b>has</b> its own BIOS on board:	The on-board SCSI BIOS will not be loaded. The adapter's own SCSI BIOS will be used.
If the SCSI adapter installed <b>doesn't have</b> its own BIOS and the card uses or is compatible with the SYM53C8XX chip:	The on-board SCSI BIOS will load and control the SCSI adapter.

*\*Disabling the onboard SCSI BIOS prevents it from being active in any way.*

**PCI Latency Timer** - This option sets latency of all PCI devices on the PCI bus. The settings are in units equal to PCI clocks. Available settings are 0 ~ 248. The default is 80.

### Load BIOS Defaults

Loads "Fail Safe" settings into the BIOS Setup program. These options are designed to slow the system down for troubleshooting purposes. To load the default values, highlight this option and press [ENTER]. Enter "Y" in the confirmation screen and press [ENTER] again. User-defined options in the **Standard CMOS Setup** are not affected.

### Load Setup Defaults

Loads the default values for best system performance into the BIOS Setup program. To load the default values, highlight this option and press [ENTER]. Enter "Y" in the confirmation screen and press [ENTER] again. User-defined options in the **Standard CMOS Setup** are not affected.

# MAINBOARD BIOS SETUP

## Integrated Peripherals Setup

This menu is used to configure the integrated IDE subsystem and other peripherals.

IDE HDD Block Mode	: Enabled	Onboard Parallel Port	: 378/IRQ7
On-Chip Primary PCI IDE	: Enabled	Onboard Parallel Mode	: ECP+EPP
IDE Primary Master PIO	: Auto	ECP Mode Use DMA	: 3
IDE Primary Slave PIO	: Auto	EPP Mode Select	: EPP 1.9
IDE Primary Master UDMA	: Auto		
IDE Primary Slave UDMA	: Auto		
On-Chip Secondary PCI IDE	: Enabled		
IDE Secondary Master PIO	: Auto		
IDE Secondary Slave PIO	: Auto		
IDE Secondary Master UDMA	: Auto		
IDE Secondary Slave UDMA	: Auto		
USB Keyboard Support	: Disabled		
KBC input Clock	: 8 MHz		
Onboard FDC Controller	: Enabled		
Onboard Serial Port 1	: 3F8/IRQ4	ESC: Quit	↑↓→←: Select Item
Onboard Serial Port 2	: 2F8/IRQ3	F1 : Help	PU/PD/+/- : Modify
InfraRed/COM2 Mode Select	: UART COM2	F5 : Old Values (Shift)	F2: Color
		F6 : Load BIOS Defaults	
		F7 : Load Setup Defaults	

**IDE HDD Block Mode** - This allows your hard disk controller to use fast block mode to transfer data to and from your hard disk drive (HDD). *Enabled* or *Disabled*. *Enabled* is the default.

**On-Chip Primary PCI IDE** - Enables or Disables the primary controller. Situations where this controller would be disabled are: a) *You are not using any IDE Drives* or b) *You are using an add-on IDE controller in a PCI Slot*.

**On-Chip Secondary PCI IDE** - Enables or Disables the secondary controller. Situations where this controller would be disabled are: a) *You are not using any IDE Drives* or b) *You are using IDE Drives ONLY on the primary controller* or c) *You are using an add-on IDE controller in a PCI Slot*.

- IDE PIO Mode** - IDE Programmed I/O Mode - This setting relates to the speed at which the hard drive is able to transfer data, up to 16.6MB/second for Mode 4 drives. Available settings are *Auto*, *0*, *1*, *2*, *3*, or *4*. As with the **Type** setting, *Auto* is the preferred choice, in that the supported PIO Mode is read directly from the hard drive. Be sure not to use a PIO Mode higher than what the drive actually supports. This could result in loss of data.

PIO Mode	Timing
0	600 ns
1	383 ns
2	240 ns
3	180 ns
4	120 ns

# MAINBOARD BIOS SETUP

---

- **IDE UDMA (Ultra DMA) Mode** - The chipset used for this mainboard improves the IDE performance by implementing UltraDMA/33 Bus Mastering IDE which can handle data transfer up to 33 Mbyte/sec. This UDMA technology is downward compatible with existing ATA-2 IDE. So there is no upgrade required for current hard drives and cabling.  
\*Auto is default.

**USB Keyboard Support** - This item allows you to enable or disable the USB keyboard driver within the onboard BIOS. The keyboard driver simulates legacy keyboard command and let you use USB keyboard during POST or after boot if you don't have USB driver in the operating system.

**KBC input Clock** - This option allows you to determine the clock of the Keyboard Controller. Options are 6, 8 (default), 12, 16 MHz.

**Onboard FDC Controller** - Set to *Enabled* if you have a floppy disk drive installed on the system board and you wish to use it. Even when so equipped, if you add a higher performance controller, you will need to disable this feature.

**Onboard Serial Port 1** - With this option, the on-board Serial Port 1 can be Disabled, or set to Auto, 3F8/IRQ4 (Default), 2F8/IRQ3, 3E8/IRQ4 or 2E8/IRQ3.

**Onboard Serial Port 2** - With this option, the on-board Serial Port 2 can be Disabled, or set to Auto, 3F8/IRQ4, 2F8/IRQ3 (Default), 3E8/IRQ4 or 2E8/IRQ3.

**InfraRed/COM2 Mode Selected** - By default, this field is set to UART COM2, which directs the second serial port UART to support the COM2 serial port. Choosing **SHARP IR (ASKIR)**, **IrDA SIR (HPSIR)**, **CIR** or **FIR** will activate the on-board infrared feature and redirect the second serial port UART to support the infrared module connector on the mainboard.

**Onboard Parallel Port** - With this option, the on-board Parallel Port can be Disabled, or set to 378/IRQ7 (\*Default), 3BC/IRQ7 or 278/IRQ5.

**Onboard Parallel Port Mode** - Sets the operating mode of the parallel port. Options are: *SPP (Standard Parallel Port)*, *EPP (Enhanced Parallel Port)+SPP*, *ECP (Extended Capability Port)* and *ECP+EPP (default)*.

**ECP Mode Use DMA** - Options are 1 and 3. This field is available only when one of the two following options in **Parallel Port Mode** is selected: ECP or ECP/EPP.

**EPP Mode Select** - Options are 1.7 and 1.9 (default ; IEEE 1284 compliant).

## Supervisor Password and User Password Setting

Passwords can be set to provide protection for the BIOS configuration options, or to restrict access to the computer itself.

When enabled, *User Password* will require all users to enter a password in order to use the system, and/or enter the BIOS setup (but can't change its contents). A *Supervisor Password* is used to protect the stored CMOS options from being changed by unauthorized users.

Keep in mind that when set, a password is required only when *booting* the system. It will not provide protection to a system that is already booted.

The password check option is set in **BIOS FEATURES SETUP** by choosing either *System* (the password prompt appears every time the system is powered on) or *Setup* (the password prompt appears only when the user enters the BIOS Setup). The password is stored in CMOS RAM, and can be cleared by removing the battery for a while and then re-installing it back.

### To set a password:

1. You must first set the *Supervisor* password by choosing *Supervisor Password* and pressing [ENTER]. Setup prompts for a password.
2. Enter a 1-8 character password using letters, numbers, or a combination of both. The specific characters are not shown as you enter them. Press [ENTER].
3. A confirmation box appears asking you to re-enter the password. Enter the password again. Press [ENTER]. Follow the same procedure to set the *User Password*.

### Changing a Password:

1. Select the appropriate password option (Supervisor or User) from the main menu and press [ENTER]. Enter the current password and press [Enter]. The screen does not display the characters entered. Enter in the new password, then the confirmation. You cannot change the current password unless you know it.

### Erasing a Password:

1. If you know the current password, but want to disable password checking, follow the procedure for changing the password. When Setup prompts for the new password, simply press [ENTER]. You will see a message indicating that the password is disabled.
2. If you do not know the current password, the CMOS must be cleared by removing the battery for a while and then re-installing it back. \*This will clear all user-defined BIOS Setup options.

# MAINBOARD BIOS SETUP

---

## IDE HDD Auto Detection

Automatically detect and configure hard disk parameters. The Award BIOS includes this ability in the event you are uncertain of your hard disk's parameters. See also "Standard CMOS Setup".

## Save & Exit Setup / Exit Without Saving

Select *Save & Exit Setup* to save into the CMOS memory all modifications specified during the current session. To save the configuration changes, highlight this option in the main menu and press [ENTER]. The system displays a confirmation message on the screen. Press the "Y" key and then [Enter]. Press the "N" key and then the [Enter] key to abort. The *Exit Without Saving* option allows the user to exit the BIOS Setup without updating any changes made during the current session.

## PCI Device Listing

This list of installed PCI devices appears after the **System Configuration** screen:

PCI device listing .....						
Bus No.	Device No.	Func No.	Vender ID	Device ID	Device Class	IRQ
0	7	1	8086	7010	IDE Controller	
14/15						
0	7	2	8086	8829	Serial bus controller	11
0	9	0	1013	7333	Display controller	NA

- Bus No.* Encoded value indicating 1 of 256 possible buses in a system.
- Device No.* Encoded value indicating 1 of 32 possible devices on a given bus.
- Func No.* Encoded value indicating 1 of 8 possible functions on a multifunction device.
- Vender ID* Identifies the manufacturer of the device. Valid vendor identifiers are allocated by the PCI SIG (Special Interest Group) to ensure uniqueness.
- Device ID* Identifies the particular device. This identifier is allocated by the vendor.
- Device Class* Specifies one of the following device classes: Mass storage controller, Network controller, Display controller, Multimedia device, Bridge device, Simple communication controller, Base system peripherals, Input device, Docking station, Processor and Serial bus controller.

The PCI device listing is useful for troubleshooting purposes. More detailed information for each field may be obtained through the PCI specification documentation.

---

# BUILT-IN SYMBIOS SCSI BIOS

To provide easy to use and cost effective support for adapters using or compatible with the Symbios Logic 53C8XX SCSI chips, this mainboard features built-in Symbios SCSI BIOS.

In most cases you should not need to change the default configuration of your host adapter. You may decide to alter these default values if there is a conflict between device settings, or if you need to optimize system performance. A message appears on your computer monitor (for about 5 seconds) during boot that looks like this:

### Press Ctrl-C to start Configuration Utility

If you decide to press Ctrl-C during boot, the following message appears:

### Please wait, invoking Configuration Utility ...

After a brief pause, your computer will display the Main Menu of the utility.

### *The Symbios SCSI Configuration Utility*

This menu driven utility allows you to view and change the default configuration settings for host adapters using Symbios 53C8XX chips.

*Note:* Pressing **Ctrl-A** after memory count during re-boot allows you to recover the default settings and reconfigure.

The following tables list the configuration settings you can change:

- Global: Affects both the adapter and all SCSI devices
- Device: Affects only the individual SCSI devices

Global Default Settings	
Settings	Default
SCAM Support	On
Parity Checking	Enabled
Host Adapter SCSI ID	7
Scan Order	Low to High (0-Max)

Device Default Settings	
Settings	Default
Synchronous Transfer Rate (MB/sec)	20
Data Width	8
Disconnect	On
Read Write I/O Timeout (secs)	10
Scan for Devices at Boot Time	Yes
Scan for SCSI LUNs	Yes
Queue Tags	Enabled

# BUILT-IN SYMBIOS SCSI BIOS

## Main Menu

MAIN MENU						
	Port Num	Irq Level	-----Status-----		NvRAM Found	
			Current	Next-Boot		
	SYM53C860	FC00	9	On	On	Yes
	SYM53C820	0	0	Off	Off	?
	SYM53C825	FD00	9	On	On	Yes
	SYM53C815	FE00	10	On	On	No
	Change Adapter Status					
	Adapter Boot Order					
	Additional Adapter Configuration					
	Display Mode = Verbose					
	Mono/Color					
	Language					
	Help					
	Quit					

You can select an adapter only if the current status is “On”. **Changes are only possible with SCSI adapters that support NVRAM (non-volatile memory).** Check the “NvRAM Found” column to see if NVRAM is present on your adapter. If you choose to alter any of these settings, exit via the **Quit** option and the system will reboot.

**Change Adapter Status** - Allows you to activate or deactivate a host adapter and all SCSI devices attached to it. The change takes place after a reboot, which is automatic upon exit from the utility when this option is changed.

**Adapter Boot Order** - Allows you to set the order in which host adapters will boot when more than one Symbios host adapter is present in the system. To change an adapter’s boot order, select it and press <Enter>. You are then prompted to enter the new boot sequence number. When the adapters are ordered properly, press the <Esc> key to exit this menu.

Boot Order						
	Port Num	Irq Level	-----Status-----		NvRAM Found	
			Current	Next-Boot		
	SYM53C860	FC00	9	On	On	Yes
	SYM53C820	0	0	Off	Off	?
	SYM53C825	FD00	9	On	On	Yes
	SYM53C815	FE00	10	On	On	No

**Display Mode** - Determines how much information about your host adapters and SCSI devices is displayed on your computer monitor during boot:

- *verbose*: for more complete information
- *terse*: for a faster boot

## BUILT-IN SYMBIOS SCSI BIOS

---

**Mono/Color** - Allows you to choose between a black and white or color display for the SCSI Configuration utility.

**Language** - English mode only.

**Help** - Brings up a help screen with information about the Main menu.

**Quit** - Exits the SCSI Configuration utility.

### *Adapter Utilities Menu*

When you select a host adapter from the main menu, the following screen is displayed:

```
SYM53C860
Utilities

Adapter Setup
Device Selections
Help
Exit this menu
```

- **Adapter Setup:** Adapter settings are viewed and changed.

```
SYM53C860
Adapter Setup

SCAM Support           On
Parity                 Enabled
Host SCSI ID          7
Scan Order             Low to High (0..Max)
Removable Media Support None
Help
Restore Default Setup
Exit this menu
```

**SCAM Support** - SCAM (SCSI Configured AutoMatically) is the SCSI Plug and Play protocol supported by Symbios BIOS version 4.X.

**Parity** - The Symbios host adapters always generate parity, but some SCSI devices do not. Therefore, you are offered the option of disabling parity checking.

*Note:* When disabling parity checking, it is also necessary to disable disconnect for all devices, as parity checking for the reselection phase will not be disabled. If a device does not supporting parity disconnects, the I/O will never complete because the reselection phase will halt.

**Host SCSI ID** - The host adapter SCSI ID should remain on 7 (default), as this setting gives the adapter the highest priority on the SCSI bus. However, if you have two adapters on the same SCSI bus, you should give one of them an unassigned ID to avoid duplication of SCSI IDs.

## BUILT-IN SYMBIOS SCSI BIOS

**Scan Order** - This option allows you to tell the host adapter BIOS and your device drivers to scan the SCSI bus from low to high (0 to max) SCSI IDs, or from high to low (max to 0) SCSI IDs. If you have more than one device on the SCSI bus, changing the scan order changes the order in which drive letters are assigned by the system.

**Removable Media Support** - Determine if the removable media will be used as BIOS device. A BIOS device here is a device that can be controlled via BIOS INT 13H, i.e. it does not need a device driver and can be bootable. However, when used as a BIOS device, the full removability of removable media devices is not preserved. The following constraints apply:

- a) The device can only work as a fixed disk, i.e. media change is not allowed.
- b) The media must be inserted before the system boot-up.
- c) Only media with 512Bytes/sector is supported.

None	The removable media devices will not be used as BIOS devices.
Boot Drive Only	Allows only the removable media installed as Drive C: to work as a BIOS device.
With Media Installed	Enables all removable disk drives to work as BIOS devices.

- **Device Selections:** Settings for the devices attached to the selected adapter are viewed and changed.

SYM53C860								
Device Selections 0-7								
	Sync Rate	Data Width	Disc	Time Out	Scan Bus	LUNS	Queue Tags	
0 - Dev0	N/A	20	8	On	10	Yes	Yes	Enabled
1 - Dev1	N/A	20	8	On	10	Yes	Yes	Enabled
2 - Dev2	N/A	20	8	On	10	Yes	Yes	Enabled
3 - Dev3	N/A	20	8	On	10	Yes	Yes	Enabled
4 - Dev4	N/A	20	8	On	10	Yes	Yes	Enabled
5 - Dev5	N/A	20	8	On	10	Yes	Yes	Enabled
6 - Dev6	N/A	20	8	On	10	Yes	Yes	Enabled
SYM53C860		20	8	On	10	Yes	Yes	Enabled
Device Selections 8-15								
Help								
Exit this menu								

The above menu provides information about individual SCSI devices attached to the selected host adapter, as well as the adapter itself. To make changes to these settings select a device from this display and press <Enter> to bring up the individual **Device Setup** menu.

## Device Setup Menu

When you select a specific device from the Device Selection menu, your computer displays the following Device Setup menu. The settings in this menu effect individual SCSI devices attached to the selected host adapter. Changes made from this menu will require a system reboot upon exit from the SCSI Configuration utility.

SYM53C860	
SYM53C860 Setup for All devices on this adapter	
Sync Rate (Mega Bytes/sec)	20
Width (bits)	8
Disconnect	On
Read Write I/O Timeout (secs)	10
Scan for Device at Boot Time	Yes
Scan for SCSI LUNS	Yes
Queue Tags	Enabled
Format Device	
Help	
Restore Default Setup	
Exit this menu	

**Sync Rate (Mega Bytes/sec)** - Defines the maximum transfer rate the host adapter attempts to negotiate. The host adapter and a SCSI device must agree to a rate they can both handle.

**Width (bits)** - Sets the maximum data width the host adapter will attempt to negotiate. The host adapter and a SCSI device must agree to a width they can both handle. Only those host adapters that support 16 bit data transfers will show this option as enabled.

**Disconnect** - SCSI devices have the ability to disconnect from the bus during an I/O transfer. This option tells the host adapter whether or not to allow a device to disconnect. Some devices run faster with disconnect *enabled* (mostly newer devices), while some run faster with disconnect *disabled* (mostly older devices).

**Read Write I/O Timeout (secs)** - This option sets the time the host adapter waits for a read, write, verify, or seek command to complete before trying the I/O transfer again. Since this provides a safeguard allowing the system to recover if an I/O operation fails, it is recommended that you always set the time-out to a value greater than zero (no time-out).

**Scan for Device at Boot Time** - When there is a device you do not wish to make available to the system, set this option to *No* for that device. Also, on a bus with only a few devices attached, you can speed up boot time by changing this setting to *No* for unused SCSI IDs.

**Scan for SCSI LUNS** - You can set this option to *No* if you have problems with a device that responds to all LUNs whether they are occupied or not.

**Queue Tags** - If your device driver can issue queue tags, this option allows you to enable or disable the issuing of queue tags during I/O requests.

**Format Device** - Low level format the selected device. All information on the drive will be erased.

## BUILT-IN SYMBIOS SCSI BIOS

---

Since some changes only take effect after your system reboots, it is important that you quit this Configuration utility properly. You should return to the Main Menu and exit via the **Quit** option. If you reboot the system without properly exiting the utility, some changes may not be saved.

### *Device Drivers*

To function properly with different SCSI devices under different operating systems you'll need to install **device drivers**. The device driver information should be available in your SCSI adapter's package.

---

# FLASH BIOS PROGRAMMING UTILITY

Updating the Award BIOS Code is made easy with the AWDFLASH Utility. Since this mainboard features FLASH BIOS, it is not necessary to change the actual BIOS chip in order to upgrade the System BIOS. The user can simply re-program the old BIOS using the AWDFLASH Utility as follows:

1. First, boot the system with DOS or to “Safe Mode” under Windows 95. If you are booting DOS from a hard drive or floppy disk, press [F5] when the message “Starting MS-DOS...” appears on the screen. If you are booting Windows 95, press the [F8] key, and select the “Safe mode command prompt” option. This will assure that the system is running in “*real mode*” with **no device drivers loaded**. *This is the only correct way to run the AWDFLASH Utility program.*
2. There are (2) important files needed to re-program the BIOS. The first is “AWDFLASH.EXE” which is the FLASH BIOS Programming Utility. The second file needed is the updated “BIN” file which contains the actual BIOS code. This file will have the extension [.bin], such as “P598GH.BIN”. Make sure these files are on the diskette or hard drive in the same directory.
3. Start the AWDFLASH Utility by changing to the directory where the two required files exist and typing: AWDFLASH and pressing [ENTER].

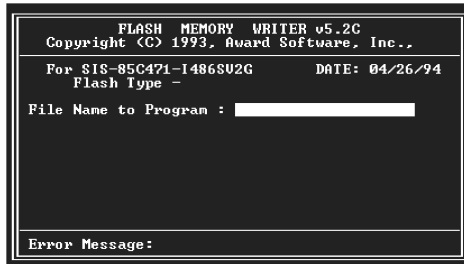

4. The AWDFLASH Utility Screen appears. You will be asked for the file name to program. Type in the name of the new BIOS (.bin) file and hit [ENTER].
5. The program will then ask if you want to backup the old BIOS. This is recommended in case there are any problems with the new “.bin” file. Enter the name of the new backup file (such as “backup.bin”) and press [ENTER].
6. At this time the system will prompt you for final confirmation before beginning programming. The Utility can be aborted at this time by hitting “n”. To begin programming, hit “y”...
7. When the Flash programming starts, a bar indicator will show the progress of the programming operation. After successful completion, hit the reset button or power off the computer.

---

# DMI UTILITY

This mainboard supports the **Desktop Management Interface (DMI)**, which is a new method of providing enterprise management for personal computers. The main component of DMI is the Management Information Format Database (MIF), which contains information about the computer system and its components, such as BIOS version/vendor, CPU speed/type, memory size/type, L1/L2 cache, port connectors (IDE, floppy, 2S/1P, USB, keyboard, mouse, ), slots ... etc. Using DMI, remote PC management software is able to obtain various information about the system, including hardware profiles, capabilities, operational status, installation dates, and other information about the system and its components.

This DMI utility, DMICFG.EXE, allows you to add additional information, such as serial numbers, vendor information, and enclosure/chassis configurations, into the MIF.

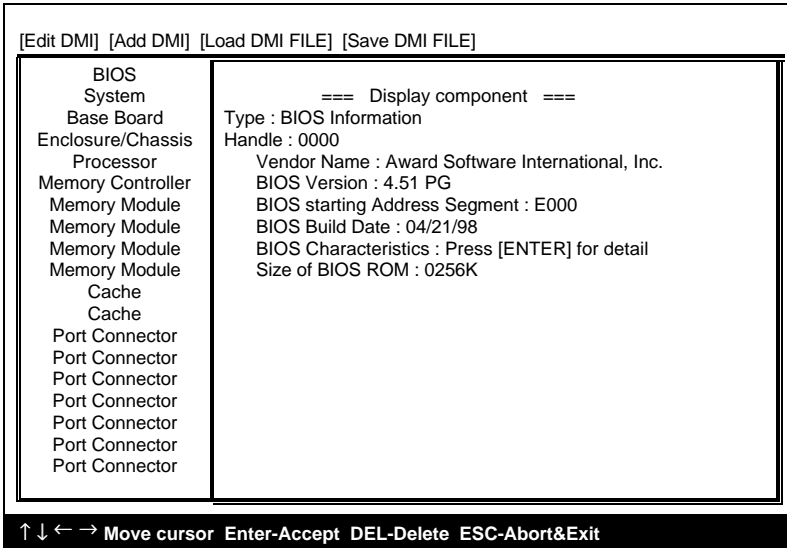

**Note:** The DMI utility must be run in real mode without the EMM386 memory manager loaded.

---

# HARDWARE MONITORING UTILITY

The mainboard has an advanced built-in hardware monitoring feature to keep track of CPU temperature, system board voltage and CPU fan speed. When an abnormal condition occurs, the system speaker will BEEP to warn the user to trouble shoot the failed part of the system.

**Note:**

When an application is using the speaker, the user may LOSE the WARNING BEEP!

The Hardware Monitor utility included with your mainboard is designed for Windows 95/Windows NT. With this utility installed, an error message will pop up under Windows 95/Windows NT in addition to the warning beep to alert the user when problem occurs.

The utility includes the following files:

- MONITOR.EXE Hardware monitor utility
- HMINSTALL.EXE Hardware monitor utility installation program
- Readme file

***Installation/Un-installation procedure:***

- Run HMINSTALL.EXE under Windows 95/Windows NT to install MONITOR.EXE to your fixed disk. MONITOR.EXE will then be executed automatically every time with Windows 95 bootup.

---

# DC-310U PCI ULTRA-SCSI ADAPTER

The DC-310U is an Ultra-SCSI Host Adapter based on the Symbios Logic SYM53C860 Ultra-SCSI Chip. Designed to provide a low cost, easy to implement SCSI solution, this adapter utilizes the built-in Symbios Logic SCSI BIOS on supported mainboards.

Fully Plug & Play and PCI 2.1 compliant, enhanced SCSI features include *Disconnect/Reconnect*, *Scatter/Gather*, and *Tag Queuing* to greatly improve overall system performance, particularly under multitasking environments.

*Jumper-less hardware design*, *Active SCSI Bus Termination*, and *32-bit PCI DMA Bus Mastering* are a few more of the advanced features built-in to the DC-310U, providing the best performance and ease of use possible.

<b>SPECIFICATIONS :</b>
-------------------------

**SCSI Performance**

- SCSI Chip:* • Symbios SYM53C860
- SCSI devices:* • Max: 7
- SCSI bus transfers:* • Async: 7MB/sec & Sync: 20MB/sec
- Bus master data transfers:* • 133MB/sec (at 33MHz)
- 80-byte DMA FIFO for 2/4/8/16 dwords burst across PCI bus

**PCI Integration**

- Full 32-bit PCI DMA bus master
- Jumper-less design
- Active SCSI bus termination

**Reliability**

- SYMTolerANT technology with:
  - Active negation of SCSI Data, Parity, Request, and Acknowledge signals for improved fast SCSI transfer rates.
  - Input signal filtering on SCSI receivers improves data integrity, even in noisy cabling environments.

**Drivers & Utilities**

- DOS, Win3.1, Win95, NT 3.5/4.x, Netware 3.x/4.x, SCO 3.2v4.2/5.0, UnixWare 2.x., OS/2 Warp
- BIOS (& Flush utility), Installation, Low Level Format.

# DC-310U PCI ULTRA-SCSI ADAPTER

---

## Mainboard BIOS Support

### Adapter Setup

#### 1. SYM53C860 Adapter Setup

S - SCAM Support ..... On  
P - Parity ..... Enabled  
I - Host Adapter ID ..... 7  
O - Scan Order ..... Low to High (0..Max)  
F1 .. Help.  
F2 .. Restore Default Setup.  
ESC .. Exit this menu.

### Device Setup

#### 1. SYM53C860 Dev0 N/A Setup

R - Sync Rate (Mega Bytes/sec) ..... 20 Mb/sec  
W - Width (bits) ..... 8  
D - Disconnect ..... On  
T - Read Write I/O Timeout (secs) ... 10  
S - Scan for Device at Boot Time ... Yes  
L - Scan for SCSI LUNs ..... Yes  
Q - Queue Tags ..... Enabled  
F1 .. Help.  
F2 .. Restore Default Setup.  
ESC .. Exit this menu.