

P5H30-NS/WS MAINBOARD

User's Manual

Rev: 1.2a

Date: 02/97

* All other products names are trademarks or copyrights of their respective owners.

TABLE OF CONTENTS

* CPU Speed Single Jumper Setup Patent is owned by Iwill Corp.

TABLE OF CONTENTS

INTRODUCTION	4
Product Description	4
Item Checklist	4
BOARD LEVEL FEATURES	5
INSTALLING THE CPU AND MEMORY	8
Static Precautions	8
Installing the CPU	8
Connecting the CPU Cooling Fan.....	8
Setting the CPU Clock Selection Jumper	9
Setting the CPU Voltage Selection Jumper	9
Installing the Memory (DRAM SIMMS)	10
The Level-2 Cache (SRAM)	10
SETTING THE JUMPERS	11
CONNECTIONS	13
Power Supply Cables	13
Serial and Parallel Ports	13
IrDA-compliant infrared module connector	13
USB Connector.....	13
Keyboard Connector	14
PS/2 Mouse Connector	14
Floppy Drives	14
IDE Hard Drives and CD-ROMs	14
8-Bit SCSI-2/3 Devices.....	15
16-Bit (Wide) SCSI-2/3 Devices	15
Optional RAIDport Module	15
MAINBOARD BIOS SETUP	16

TABLE OF CONTENTS

About the BIOS	16
Using Setup	16
Getting Help	16
A Final Note About Setup	16
MAIN MENU	17
STANDARD CMOS SETUP	18
BIOS FEATURES SETUP	21
CHIPSET FEATURES SETUP	24
POWER MANAGEMENT SETUP	27
PNP/PCI CONFIGURATION SETUP	29
LOAD BIOS DEFAULTS	30
LOAD SETUP DEFAULTS	30
INTEGRATED PERIPHERALS	31
SUPERVISOR PASSWORD AND USER PASSWORD SETTING	33
IDE HDD AUTO DETECTION	34
SAVE & EXIT SETUP / EXIT WITHOUT SAVING	34
PCI Device Listing	34
DMI UTILITY	35
FLASH BIOS PROGRAMMING UTILITY	36
ADAPTEC® SCSISelect™ UTILITY	37
Configure/View On-board Host Adapter Settings Menu	38
SCSI Disk Utilities	45
ARO™ -1130 PCIRAIIDport™ Card	46
<input checked="" type="checkbox"/> MAINBOARD DIAGRAMS	
<i>Board Level Features</i>	<i>5</i>
<i>Comprehensive Mainboard View</i>	<i>7</i>

TABLE OF CONTENTS

Jumper Locations 11

INTRODUCTION

Product Description

The **P5H30-NS/WS** represents the highest level of technology available in PC Mainboards today. Designed as a flexible, high-performance and cost-effective solution for System Integrators and End Users alike, the P5H30-NS/WS provides the power and expandability to meet the requirements of the most advanced operating systems and software applications.

Support for Intel® Pentium® processors at speeds of up to 200Mhz is just the beginning. The P5H30-NS/WS is designed to provide greater overall system throughput by utilizing the latest in I/O technology. By incorporating such advanced features as Ultra SCSI (P5H30-NS), Ultra-Wide SCSI (P5H30-WS), Bus Mastering IDE and Universal Serial Bus (USB) onto the mainboard, optimum system performance is assured and system design and implementation is simplified.

Fully “Plug & Play” compatible via an Award BIOS, the P5H30-NS/WS facilitates easy system configuration and peripheral setup. With support for up to 512MB of System RAM, EDO and ECC, the P5H30-NS/WS is the ideal foundation for high-end computer systems.

Item Checklist

Your mainboard package should include the items listed below. Damaged or missing items should be reported to your vendor.

- | | |
|--|---|
| <input checked="" type="checkbox"/> The P5H30-NS/WS mainboard | <input checked="" type="checkbox"/> Adaptec 7800 Family (2) driver diskettes |
| <input checked="" type="checkbox"/> Mounting bracket with (1) serial COM2 port ribbon cable attached | <input checked="" type="checkbox"/> Adaptec 7800 Family manual |
| <input checked="" type="checkbox"/> Mounting bracket with (1) parallel & (1) serial COM1 port ribbon cables attached | <input checked="" type="checkbox"/> Diskette containing support software for updating the FLASH BIOS and IDE drivers |
| <input checked="" type="checkbox"/> Floppy disk drive ribbon cable | <input type="checkbox"/> Optional PS/2 connector Module |
| <input checked="" type="checkbox"/> (1) IDE ribbon cable | <input type="checkbox"/> Optional Infrared Module |
| <input checked="" type="checkbox"/> 50-pin Internal SCSI-2 ribbon cable | <input type="checkbox"/> Optional USB Module |
| <input checked="" type="checkbox"/> This User's Manual | <input type="checkbox"/> Optional 68-pin Internal Wide SCSI ribbon cable with External Bracket (<i>P5H30-WS Only</i>) |
| <input checked="" type="checkbox"/> Adaptec EZ-4.xx driver diskette | <input type="checkbox"/> Optional 68-pin Internal Wide SCSI ribbon cable (<i>P5H30-WS Only</i>) |
| <input checked="" type="checkbox"/> Adaptec EZ-SCSI 4.0 manual | |

BOARD LEVEL FEATURES

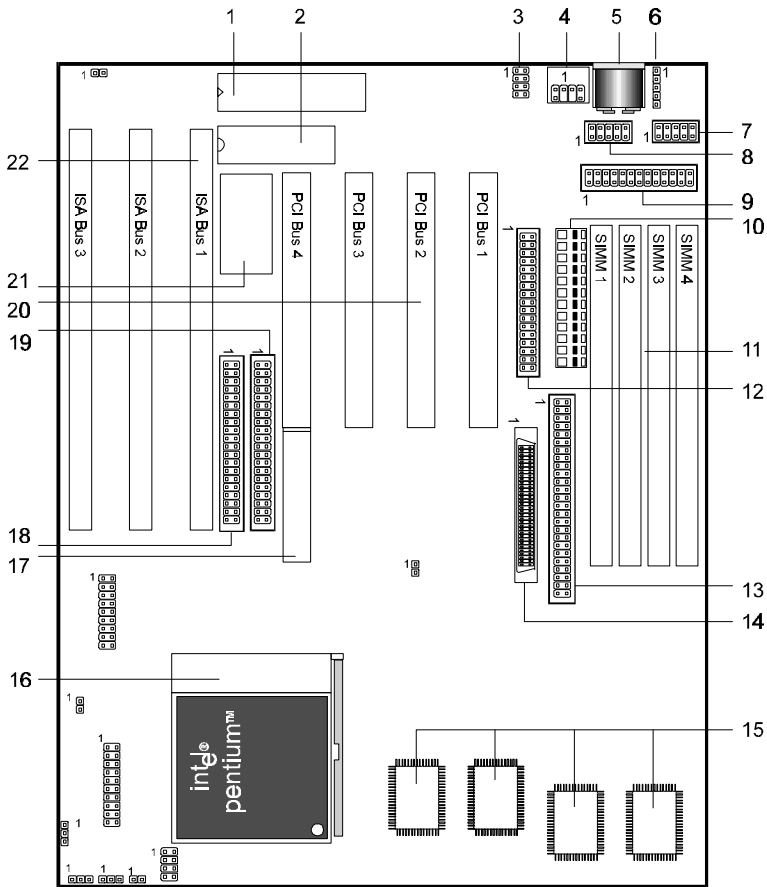

- | | |
|----------------------------|---------------------------------|
| 1. Keyboard BIOS | 12. Floppy connector |
| 2. Mainboard BIOS | 13. Ultra / SCSI-2 connector |
| 3. USB connector | 14. * Ultra-Wide SCSI connector |
| 4. PS/2 mouse connector | 15. L2 Pipeline-burst cache |
| 5. AT-keyboard connector | 16. CPU socket |
| 6. Infrared (IR) connector | 17. * Adaptec RAIDport |
| 7. COM2 connector | 18. Primary IDE connector |
| 8. COM1 connector | 19. Secondary IDE connector |
| 9. Printer port connector | 20. PCI slots |
| 10. Power connector | 21. Real Time Clock/Battery |
| 11. DRAM SIMM sockets | 22. ISA slots |

* P5H30-WS only

BOARD LEVEL FEATURES

1. **KEYBOARD BIOS:** Firmware chip controlling keyboard operations.
2. **MAINBOARD BIOS:** Award BIOS supporting “Plug and Play”, DMI, Green PC specification, on screen setup for Adaptec SCSI, Enhanced IDE and Multi-I/O. The BIOS is FLASH Upgradeable via the AWDFLASH Utility.
3. **USB CONNECTOR:** A connector for an optional USB (Universal Serial Bus) module is provided. This connector permits the connection of two USB peripheral devices directly to the port without an external hub. USB is a new technology supporting keyboards, mouse, printers, fax modems and other telephony devices.
4. **PS/2 MOUSE CONNECTOR:** Connector for optional PS/2 mouse bracket/connector. If you are using a PS/2 mouse, you must purchase this bracket to insert into your PC and connect to the PS/2 mouse pin-header on the mainboard.
5. **AT-KEYBOARD CONNECTOR:** Supports IBM compatible AT style keyboards.
6. **INFRARED (IR) CONNECTOR:** UART2 can also be used for the optional Infrared Module, enabling wireless communication capability. A supplied bracket with a single customized cable connects directly to the infrared pin-header on the mainboard.
7. **COM2 CONNECTOR:** High-speed UART compatible serial port. COM2 can be directed to the Infrared Module for wireless connection capability.
8. **COM1 CONNECTOR:** High-speed UART compatible serial port.
9. **PRINTER PORT CONNECTOR:** EPP and ECP compatible parallel port.
10. **POWER CONNECTOR:** 12-Pin Power Connector.
11. **DRAM SIMM SOCKETS:** (4) 72-pin SIMM sockets are provided to support a maximum RAM memory capacity of 512 MB. SIMM types of either Fast Page Mode (FPM) or Extended Data Output (EDO) are supported and automatically detected by the BIOS. ***ECC Support:** The Intel 430HX PCIset chipset can detect and correct 1-bit memory errors when DRAM SIMM modules supporting parity are used.
12. **FLOPPY CONNECTOR:** Built-in floppy controller supports (2) 5.25" or 3.5" (1.44MB or 2.88MB) floppy drives.
13. **ULTRA SCSI CONNECTOR:** Supports up to 7 SCSI-2 or Ultra-SCSI devices. The on-board Adaptec AIC-78x0 SCSI BIOS supports additional Adaptec PCI-SCSI 2940UW controllers, along with the on-board AIC-78x0 controller.
14. **ULTRA WIDE SCSI CONNECTOR:** Supports up to 15 Wide SCSI or Ultra-Wide SCSI devices. (*P5H30-WS Only*)
15. **L2 PIPELINE-BURST CACHE:** Supports Write Back Secondary Cache with 512KB Pipeline Burst SRAM.
16. **CPU SOCKET:** ZIF Socket 7 for Pentium CPUs. This mainboard supports CPU speeds of 75-200mhz for Intel, AMD and Cyrix. Setting the CPU frequency and bus speed requires only **one** jumper change.

BOARD LEVEL FEATURES

17. **ADAPTEC® RAIDport™ CONNECTOR:** This connector, located behind PCI slot 4, supports the Adaptec multifunction expansion card for RAID subsystems. This connector does not interfere with the use of standard PCI cards with PCI slot 4.
18. **PRIMARY IDE CONNECTOR:** Connector for first IDE channel. The on-board PCI Bus Mastering IDE controller features support for DMA Mode 2 and PIO Modes 3 and 4 for faster data transfer rates. (2) Connectors are provided for support of up to (4) IDE devices on two channels. Other ATAPI and Enhanced IDE devices such as Tape Drives and CD-ROMs are also supported.
19. **SECONDARY IDE CONNECTOR:** Connector for second IDE channel.
20. **PCI SLOTS:** (4) 32-bit PCI slots are provided.
21. **REAL TIME CLOCK:** Circuitry responsible for the system time and date.
22. **ISA SLOTS:** (3) 16-bit ISA slots

Comprehensive Mainboard View

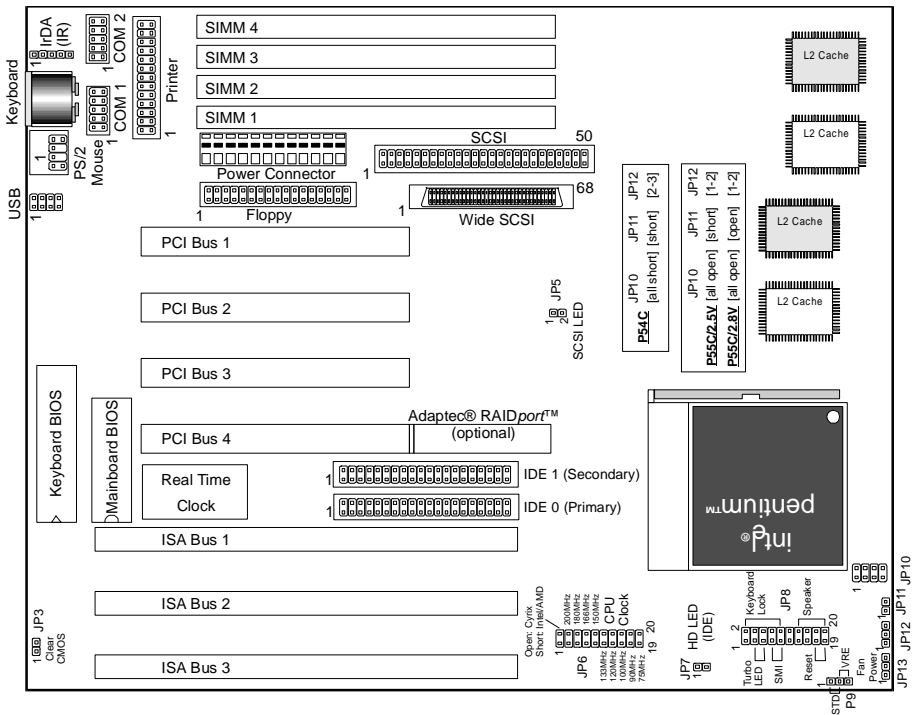

INSTALLING THE CPU AND MEMORY

Static Precautions

Static electricity can be a serious danger to the electronic components on this mainboard. To avoid damage caused by electrostatic discharge, observe the following precautions:

- ✓ Don't remove the mainboard from its anti-static packaging until you are ready to install it into a computer case.
- ✓ Before you handle the mainboard in any way, touch a grounded, anti-static surface, such as an unpainted portion of the system chassis, for a few seconds to discharge any built-up static electricity.
- ✓ Handle add-in cards and modules by the edges or mounting bracket.

Installing the CPU

- ✓ **WARNING:** Use of a CPU Cooling Fan to prevent CPU overheating is highly recommended. The Fan should be installed first before inserting the CPU into its socket.
1. Locate the ZIF (Zero Insertion Force) Socket 7. This socket supports Pentium (P5) CPUs (75-200Mhz).
 2. First open the socket by pulling the lever sideways, then upwards. Notice how the lever locks in place when pressed all the way down.
 3. The CPU must be inserted with the correct orientation. One corner of the CPU has a "notch" and looks different than the other three. This corner is also missing a pin unlike the other three and is marked with a white dot on top of the CPU. Align this corner towards the end of the lever as shown in the figure below. Insert the CPU, hold it down, and close the lever until it locks into place.

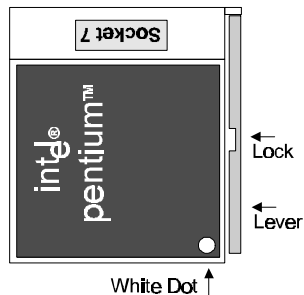

Connecting the CPU Cooling Fan (JP13)

JP13 is a small 3-pin Header Connector that provides 12-Volt power for CPU Cooling Fans. This is useful if your Fan provides this type of connector, instead of the normal Molex-Type Power-Supply connector. Pin-2 corresponds to the RED power lead as shown:

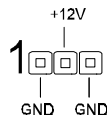

INSTALLING THE CPU AND MEMORY

Setting the CPU Clock Selection Jumper (JP6)

After installing the CPU, you must set the clock selection jumper to match the frequency of the CPU. Find the Jumper Block labeled JP6 on the mainboard (Refer to the diagram on page 7). Set the jumper according to the table below for the CPU frequency you are using.

The Internal (Core) frequency corresponds to the number marked on the CPU. The External Frequency when multiplied with the Ratio gives the CPU's internal frequency. This jumper automatically sets the ISA Clock as well.

* If you are uncertain about the speed or voltage requirements of your particular CPU, you should obtain Technical Documentation from the manufacturer.

Such information is available via the Intel, Cyrix and AMD WWW sites.

Intel & AMD CPU: [1,2] short





Internal	Ratio	External	JP6
75MHz	1.5x	50MHz	[19, 20]
90MHz	1.5x	60MHz	[17, 18]
100MHz	1.5x	66MHz	[15, 16]
120MHz	2.0x	60MHz	[13, 14]
133MHz	2.0x	66MHz	[11, 12]
150MHz	2.5x	60MHz	[9, 10]
166MHz	2.5x	66MHz	[7, 8]
180MHz	3.0x	60MHz	[5, 6]
200MHz	3.0x	66MHz	[3, 4]

Cyrix CPU: [1,2] open

Product	Ext/Int	JP6
6x86-P120+	50/100MHz	[13, 14]
6x86-P133+	55/110MHz	[11, 12]
6x86-P150+	60/120MHz	[9, 10]
6x86-P166+	66/133MHz	[7, 8]

Setting the CPU Voltage Selection Jumper (JP9, JP10, JP11, JP12)

Locate Jumpers JP9, JP10, JP11 and JP12 on the mainboard (Refer to the diagram on page 10). Set these jumpers in accordance with the table below for your specific CPU type (Refer to the CPU documentation)

Voltage	JP9	JP10	JP11	JP12
Intel P54C / AMD K5 / Cyrix 6x86				
STD (3.3V)	[1, 2]		[short]	[2, 3]
VRE (3.52V)	[2, 3]		[short]	[2, 3]
Intel P55C & Cyrix 6x86L (dual supply)				
Core (2.5V)	N/A		[short]	[1, 2]
Core (2.8V)	N/A		[open]	[1, 2]

INSTALLING THE CPU AND MEMORY

Installing the Memory (DRAM SIMMS)

- The P5H30-NS/WS mainboard supports **72-pin SIMMS** of two types:
 - **Fast Page Mode** (Asymmetric or Symmetric)
 - **EDO** (Extended Data Output)
 - SIMM Sizes supported: **4MB, 8MB, 16MB, 32MB, 64MB, and 128MB**
 - A total of **(4)** SIMMS can be installed for a maximum RAM capacity of **512MB**. (With four 128MB SIMMS Installed)
 - Minimum RAM capacity is **8MB** (With (2) 4MB SIMMS Installed)
 - SIMMS speed requirements: 70ns or 60ns
1. This mainboard contains (2) SIMM Banks. Each bank consists of (2) SIMM Sockets. **Memory must be installed two SIMMS (1 Bank) at a time. The two SIMMS in a bank must be identical.**
 1. Install SIMMS 1 and 2 first. The SIMMS must be oriented in the correct way. There is a notch in one end of the SIMM. Align this notch as shown in the Diagram below. Retainers on either side of the SIMM will hold it in place.

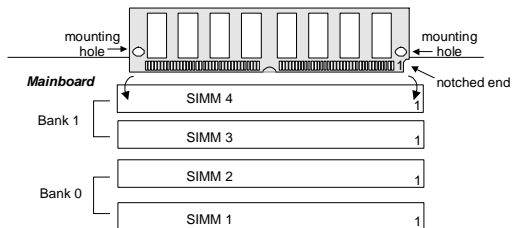

The Level-2 Cache (SRAM)

Your mainboard features 512K of Pipeline-Burst Static RAM Cache Memory. Locate the L2 Cache on the Diagram on page 5. Two possible implementations are available: Four 32Kx32 128K chips or Two 64Kx32 256K chips.

The 512K of Level-2 Cache on this mainboard is *not* upgradeable.

SETTING THE JUMPERS

Jumpers are used on this mainboard to select various settings and features. A 2-pin jumper has two settings: Open and Short (or Closed). The jumper is closed by placing the Jumper Cap across the two pins. 3-pin jumpers can be set to pins 1-2 or 2-3 connected. Pin-1 is labeled on the circuit board for these jumpers as shown:

3-pin Jumper

Pin 1-2



Pin 2-3



2-pin Jumper

Open



Short

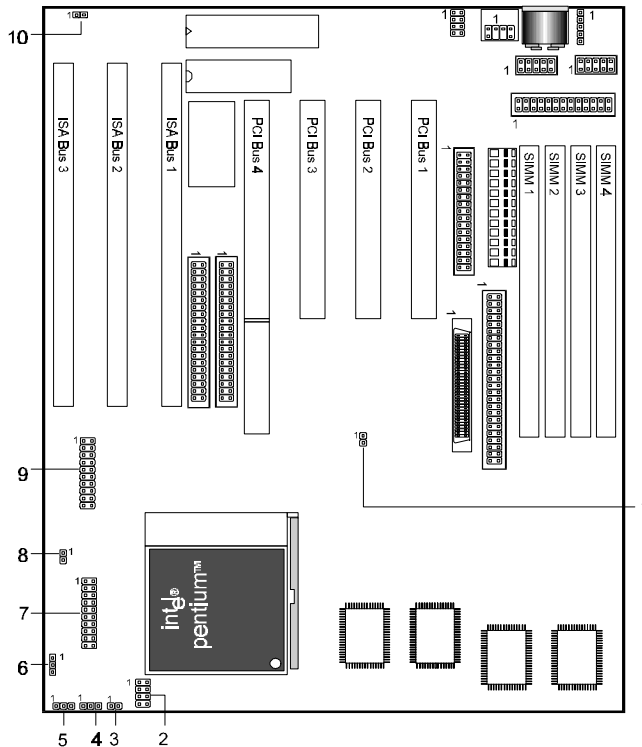

1. **JP5**
2. **JP10**
3. **JP11**
4. **JP12**
5. **JP13**
6. **JP9**
7. **JP8**
8. **JP7**
9. **JP6**
10. **JP3**

JP3: Clear CMOS RAM - When closed, the CMOS information is reset to default. All user-entered information is cleared. To clear the CMOS, first turn the computer off, then connect a jumper cap over the two pins for a moment. Remove the jumper and power the system on.

SETTING THE JUMPERS

JP5: IDE Activity LED - Hook the IDE LED lead to this jumper, with the RED lead corresponding to Pin-1.

JP6: CPU Clock Selection - This jumper is explained in detail on page 9.

JP7: SCSI Activity LED - Hook the SCSI LED lead to this jumper, with the RED lead corresponding to Pin-2.

JP8: System Functions Jumper Block

Pins [3 & 5] Turbo LED switch - The Turbo function is not supported by this mainboard. Therefore, the Turbo LED will always remain lit as long as the system power is on.

Pins [7 & 9] SMI suspend switch lead - If your system's case has a suspend switch, hook the lead from the switch to pins 7 & 9 of JP8. A suspend switch is used to save electricity by putting the system into a suspend mode when the computer is not being used. This switch could also be used by the Turbo switch on the front of the system, since this mainboard does not support that function. For this switch to be functional, it must first be enabled in the Power Management Setup in the BIOS Setup utility.

Pins [17 & 19] Reset switch lead - Connects to the Reset Switch lead from the system's case. The reset switch is used to "cold-boot" the system without actually turning off the power, reducing wear and tear on the power supply.

Pins [2, 6, 8, 10] Keyboard lock switch lead - Pins 2 & 6 connect to the Power LED from the system's case. Pins 8 & 10 connect to the case-mounted keylock switch.

Pins [14 & 20] Speaker connector - Connects to the Speaker lead from the system's case.

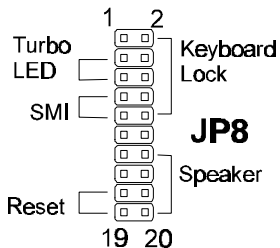

JP9, JP10, JP11, JP12: CPU Voltage Selection Jumper - This jumper is explained in detail on page 9.

JP13: CPU cooling fan connector - Hook the CPU cooling fan power connector to this jumper, observing the correct polarity. Pin-2 corresponds to the RED power lead as shown:

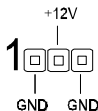

Power Supply Cables

The two cables from the standard 5-volt power supply connect to the power connector on the mainboard (refer to page 4). You must align the connectors on the power cable at a slight angle to correctly fit them onto the mainboards power connector. Then, press down on the connectors to lock them in place. The (2) connectors should be installed so that the BLACK wires meet in the middle of the connector.

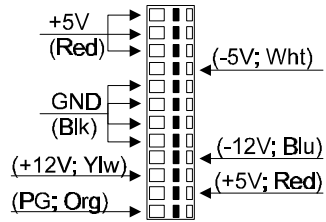

Serial and Parallel Ports

The cables from the supplied serial port connector bracket hook to the COM1 and COM2 connectors on the mainboard. Generally, the upper serial port on the bracket would be configured as COM1 and the lower port as COM2. Make sure to orient Pin-1 marked on the mainboard to the RED stripe on the ribbon cables.

The cable from the supplied parallel port connector bracket hooks to the parallel connector on the mainboard. Make sure to orient Pin-1 marked on the mainboard to the RED stripe on the ribbon cable.

IrDA-compliant infrared module connector

The IrDA connector bracket hooks directly to this connector on the mainboard. This connector provides support for the optional wireless transmitting and receiving infrared module. You must first configure through the BIOS setup where UART2 is directed, COM2 or IrDA.

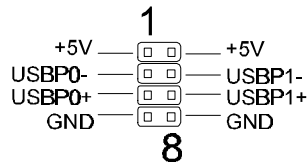
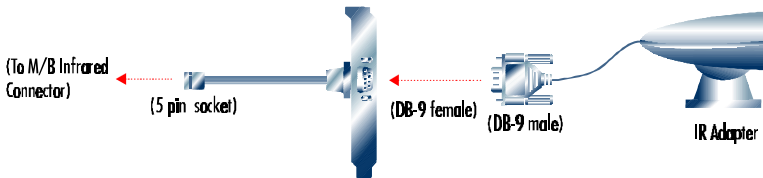
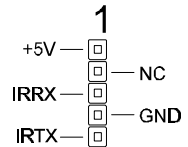

USB Connector

CONNECTIONS

This 8-pin connector permits connection of two USB peripheral devices directly to the system without an external hub.

Keyboard Connector

This connection is for a standard IBM-compatible keyboard. May also be known as a 101 enhanced keyboard.

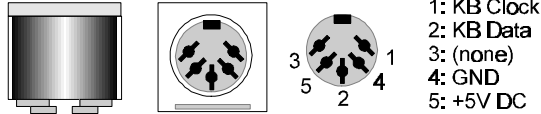

PS/2 Mouse Connector

If you are using a PS/2 mouse, you must purchase one bracket to insert into your PC and a single customized cable to directly connect to the PS/2 mouse pin-header on your mainboard.

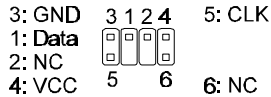

Floppy drives

The on-board floppy controller supports (2) floppy disk drives with the floppy ribbon cable provided. Make sure the RED stripe on the ribbon cable is oriented towards Pin-1. Notice the “twist” between the sets of connectors on the floppy cable. The floppy drive “A” position is at the END of the cable, whereas floppy drive “B” is hooked to one of the connectors on the other side of the twist. The cable provides both “Edge” and “Pin” connectors for both the A and B positions to match the connector on your floppy drives.

IDE Hard Drives and CD-ROMs

The on-board Enhanced IDE controller can support up to (4) IDE hard drives or other ATAPI devices, such as CD-ROMs. This controller, as with all Enhanced IDE controllers, consists of both **Primary** and **Secondary** ports. Each port has an associated connector and cable which can support up to (2) ATAPI devices each.

All IDE devices have jumpers which allow the user to configure the device as either “Master” or “Slave”. A Master device is one that is ALONE on the IDE cable, whereas a Slave device is installed as a SECOND device on the same cable. Keep in mind that the Master device will appear *before* the Slave device in the CMOS Setup, as well as the Operating System software. *Refer to the device documentation for jumper settings.

The Secondary IDE port can be used for up to (2) additional ATAPI devices. Normally it’s recommended that you connect your first hard drive to the Primary port, and the first CD-ROM to the Secondary.

CONNECTIONS

Make sure to align the RED stripe on the ribbon cable with Pin-1 on the mainboard IDE connector. On most hard drives and CD-ROMs, the RED stripe should be oriented towards the power connector of the device.

8-Bit SCSI-2/3 Devices

The 50-pin Ultra SCSI connector is capable of supporting up to (7) 8-bit SCSI-2 or SCSI-3 devices. Remember that the on-board controller uses the “SCSI ID” of 7. So, when hooking up your SCSI devices, start with ID 0, and avoid ID 7. As with all SCSI Controllers, only the LAST device on the cable should be terminated.

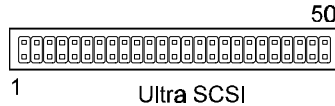

16-Bit (Wide) SCSI-2/3 Devices

- The 68-pin Ultra-Wide SCSI connector is featured on the P5H30-WS mainboard. It can support up to (15) 16-bit SCSI devices. These include Wide SCSI-2 and Ultra-Wide devices. Remember the controller’s SCSI ID is 7. So, avoid ID 7 when configuring your SCSI devices. As with all SCSI Controllers, only the LAST device on the cable should be terminated.
- Both the 8-bit and 16-bit connectors represent the same SCSI bus. The total number of devices for this controller is (15). This means that once a SCSI ID is used on one of the cables, that ID cannot be used again. The maximum of (15) devices could consist of all 16-bit devices, or a mixture of 16-bit and 8-bit devices. (*P5H30-WS Only*)



Optional RAIDport Module

You can take greater advantage of the Ultra-Wide SCSI controller already embedded on the P5H30-WS mainboard by turning it into a hardware assisted RAID solution through the addition of the Adaptec® RAIDport™ Module. This PCI add-in card contains the Adaptec RAID engine ASIC (Application Specific Integrated Circuit) and its associated hardware. This is the most cost effective, flexible, and risk-free way to add RAID functionality to your SCSI subsystem.

This solution is also particularly cost effective since it takes advantage of the embedded SCSI controller and avoids the extra cost of the PCI-to-PCI bridge that is present in most high performance RAID solutions. Furthermore no recabling of the SCSI devices is required.

MAINBOARD BIOS SETUP

About the BIOS

The **Mainboard BIOS** (Basic Input/Output System) acts as the bridge between your *Hardware* (CPU, Disk Drives, Video, etc.) and Operating System *Software* (Windows 95, OS/2 and so on...) The BIOS Setup (also called CMOS Setup) is where many hardware configuration options are set and stored. This configuration information will remain in the BIOS until it is changed, or cleared via the “Clear CMOS” jumper (see page 11).

CMOS (Complementary Metal Oxide Semiconductor) refers to the chip in which the BIOS information is stored.

The P5H30-NS/WS mainboard features **Award BIOS**, which provides an easy to use Setup program to aid in hardware configuration. In this section we will look at the various menus and options contained in the Award BIOS Setup Program. This mainboard also features a “Flash” BIOS. A Flash BIOS can be upgraded via software, thereby eliminating the need to actually replace the “BIOS Chip” on the mainboard. Procedures for updating the BIOS follow this section.

The Award BIOS installed in your computer system’s ROM (Read Only Memory) is a custom version of an industry standard BIOS. This means that it supports Intel/Cyrix/AMD processors in a standard IBM-AT compatible input/output system.

Using Setup

In general, you use the arrow keys to highlight items, press <Enter> to select, use the PageUp and PageDown keys to change entries, press <F1> for help and press <Esc> to quit.

Getting Help

Pressing F1 will display a small help window that describes the appropriate keys to use and the possible selections for the highlighted item. To exit the Help Window press <Esc>.

A Final Note About Setup

Not all systems have the same Setup. While the basic look and function of the Setup program remains the same for all systems, individual motherboard and chipset combinations require custom configurations. For example, you may find that your Setup main menu has a different number of entries from the main menu displayed in this manual. These are simply features not supported (or not user configurable) on your system.

The final appearance of the Setup program also depends on the Original Equipment Manufacturer (OEM) who built your system. If your OEM has decided that certain items should only be available to their technicians, those items may very well be removed from the Setup program.

MAINBOARD BIOS SETUP

- Shortly after the system is powered on, provided a CPU and sufficient RAM are installed, you will see the message: *Press **DEL** to enter **SETUP**.*
- Press the DEL key to enter the Award BIOS Setup program.

MAIN MENU

Once you enter the Award BIOS CMOS Setup Utility, the Main Menu will appear on the screen. The Main Menu allows you to select from several setup functions and two exit choices. Use the arrow keys to select among the items and press <Enter> to accept and enter the sub-menu.

ROM PCI/ISA BIOS (2A59F008)
CMOS SETUP UTILITY
AWARD SOFTWARE, INC.

STANDARD CMOS SETUP	INTEGRATED PERIPHERALS
BIOS FEATURES SETUP	SUPERVISOR PASSWORD
CHIPSET FEATURES SETUP	USER PASSWORD
POWER MANAGEMENT SETUP	IDE HDD AUTO DETECTION
PNP / PCI CONFIGURATION	SAVE & EXIT SETUP
LOAD BIOS DEFAULTS	EXIT WITHOUT SAVING
LOAD SETUP DEFAULTS	
Esc : Quit	↑ ↓ → ← : Select Item
F10 : Save & Exit Setup	(Shift) F2 : Change Color
Time, Date, Hard Disk Type...	

Note that a brief description of each highlighted selection appears at the bottom of the screen.

MAINBOARD BIOS SETUP

STANDARD CMOS SETUP

This first menu is where the most basic hardware options are set. Information regarding the system clock, IDE hard disks and floppy drives is stored and configured in this section. To enter the Standard CMOS Setup, press the [ENTER] key with this menu highlighted.

Date (mm:dd:yy) : Fri, Apr 7 1996								
Time(hh:mm:ss) : 00:00:00								
HARD DISKS	TYPE	SIZE	CYLS	HEAD	PRECOMP	LANDZ	SECTOR	MODE
Primary Master	: Auto	0	0	0	0	0	0	Auto
Primary Slave	: Auto	0	0	0	0	0	0	Auto
Secondary Master	: Auto	0	0	0	0	0	0	Auto
Secondary Slave	: Auto	0	0	0	0	0	0	Auto
Drive A : 1.44M , 3.5in.								
Drive B : None								
Floppy 3 Mode Support: Disabled								
Video : EGA / VGA								
Halt On : All Errors								
			Base Memory			: 640K		
			Extended Memory			: 15360K		
			Other Memory			: 384K		
			Total Memory			: 16384K		
ESC : Quit			↑ ↓ → ← : Select Item			PU / PD / + / - : Modify		
F1 : Help			(Shift) F2 : Change Color					

Upon entering the Standard CMOS Setup screen, you will see a screen like that below. Again, notice that the bottom of the screen provides information relating to the highlighted item as you move around the screen.

First, let's set the system **Date**. Use the arrow keys to move to and highlight the "Date" option. Select the Month by using the PgDn and PgUp keys. This is how most settings will be configured. Then, move to the day, year and time via the arrow keys to finish setting the system date and time.

Keep in mind that the system time is set in 24-hour time. With this method, 1PM is represented as 13:00, 2PM as 14:00 and so on, with 00:00 corresponding to Midnight.

Pri Master, Pri Slave, Sec Master, Sec Slave - These four options relate to the (4) IDE hard drives, CD-ROMs or other ATAPI devices that can be controlled via the on-board IDE controller (review *IDE Hard Drives and CD-ROMs* on page 13). The "Pri Master" setting specifies the first device on the primary IDE channel, "Pri Slave" - the second. Sec Master and Sec Slave specify the devices on the secondary channel.

The first option available is the most important: **Type**. This is where you will specify the type of device and how it is represented in the BIOS Setup. If the device is a hard disk or

MAINBOARD BIOS SETUP

CD-ROM, generally the *Auto* option is the best choice for fast and easy setup of the hard disk parameters. Let's take a look at the difference between the *Auto*, *User* and *Types (1-45)* options:

- **Auto** - This option instructs the BIOS to automatically configure the hard disk by reading the parameters (cylinders, sectors, etc.) directly from the hard disk's firmware. Use this option if you are configuring a new hard drive, or one that has already been formatted using the *Auto* option. Keep in mind that a hard drive is configured using a certain set of parameters, those same parameters must be used for the life of the drive, unless the drive is re-FDISKed using a different parameter set. (This procedure deletes the old partition(s) on the drive and creates a new one, using the new parameters).
- **User** - This option allows you to manually enter in the parameters of the hard drive. Generally, this option would be used only if the hard drive has already been formatted with a certain set of parameters, and assured consistency between the old and new parameters is desired.
- **Types 1-45** - Similar to the *User* option, these types should only be used if the exact parameters for the hard drive are already entered as a specific type stored in the Setup Program. Again, this would only be needed to assure that the parameters the drive was formatted with and those it is using now, are identical. For new hard drives, the *Auto* option is the preferred choice.

TYPE	drive type
CYLS.	number of cylinders
HEADS	number of heads
PRECOMP	write precom
LANDZONE	landing zone
SECTORS	number of sectors
MODE	mode type

Mode - One of Enhanced IDE's most important features is LBA (Logical Block Addressing) Mode. This feature allows the use of larger hard drives by providing a way to bypass the cylinder limitations imposed by many Operating Systems. LBA Mode is used to extend a hard drive's useable capacity by "remapping" the cylinders in a way that is acceptable to these operating systems. For instance, a hard drive with the parameters of 2100 Cylinders, 16 Heads and 63 Sectors would be represented by LBA Mode as 525 Cylinders, 64 Heads and 63 Sectors. (Notice that the Cylinders have been divided, and the Heads have been multiplied, by a factor of 4)

On hard drives smaller in capacity than 528MB, LBA support is not needed. The option on these devices is ignored, even if enabled. For hard drives greater than 528MB, LBA mode should be enabled. The following rules apply:

- Operating Systems that do not use the FAT file system do not need LBA Mode, and can use the Normal or Large Modes. Examples would be Netware and Unix.
- When configuring a new hard drive greater than 528MB in capacity, always make sure LBA mode is enabled.
- If you are using a hard drive that is over 528MB in capacity, but was already formatted

MAINBOARD BIOS SETUP

without using LBA mode, LBA support will be ignored even if it is enabled. This assures correct access to the drive's data.

- **SCSI Hard Drives** are NOT entered into the Mainboard BIOS Setup in any way. The hard drive settings in the Standard CMOS Setup are only for drives connected to the IDE Controller. So, if only SCSI drives were installed, all these settings would be set to **Type: None**. SCSI Devices are configured via the SCSI controller's BIOS.

Floppy Drives A: and B: - Select the Type for the A: and/or B: floppy drives. Remember, floppy drive A: is the first drive, hooked to the END of the floppy ribbon cable. Floppy drive B: is hooked up after the twist. Available settings are listed below:

None	No floppy drive installed
360K, 5.25 in	5-1/4 inch PC-type standard drive; 360 kilobyte capacity
1.2M, 5.25 in	5-1/4 inch AT-type high-density drive; 1.2 megabyte capacity
720K, 3.5 in	3-1/2 inch double-sided drive; 720 kilobyte capacity
1.44M, 3.5 in	3-1/2 inch double-sided drive; 1.44 megabyte capacity
2.88M, 3.5 in	3-1/2 inch double-sided drive; 2.88 megabyte capacity

Floppy 3 Mode Support: - Enable this option **ONLY** for floppy drive(s) that support the Japanese standard (1.2MB on 3.5" Diskette). Options: Disabled (Default), Both, Drive A / B.

Video - This category selects the type of video adapter used for the primary system monitor. Although secondary monitors are supported, you do not have to select their type in Setup.

EGA/VGA	Enhanced Graphics Adapter/Video Graphics Array. For EGA, VGA, SEGA, SVGA or PGA monitor adapters.
CGA 40	Color Graphics Adapter, power up in 40 column mode
CGA 80	Color Graphics Adapter, power up in 80 column mode
MONO	Monochrome adapter, includes high resolution monochrome adapters

Error Halt - Determines whether or not the system will prompt you if an error is detected during POST.

No errors	The system boot will not be stopped for any error that may be detected.
All errors	Whenever the BIOS detects a non-fatal error the system will be stopped and you will be prompted.
All, But Keyboard	The system boot will not stop for a keyboard error; it will stop for all other errors.
All, But Diskette	The system boot will not stop for a disk error; it will stop for all other errors.
All, But Disk/Key	The system boot will not stop for a keyboard or disk error; it will stop for all other errors.

Memory - This category is display-only. All memory detected by the POST (Power On Self Test) of the BIOS is shown as the following types:

Base Memory is the amount of conventional memory installed in the system. This value is typically 640K for systems with 640K or more memory installed on the motherboard. The

MAINBOARD BIOS SETUP

Extended Memory is the amount of memory located above 1MB in the CPU's memory address map. **Other Memory** refers to the memory located in the region between 640K and 1MB. This region can be used for *shadowing* as well as *expanded memory* in DOS.

BIOS FEATURES SETUP

This menu provides access to more advanced BIOS configuration settings that deal with overall performance of the system and peripheral setup. This section allows you to configure your system for basic operation. You have the opportunity to select the system's default speed, boot-up sequence, keyboard operation, shadowing and security.

Virus Warning	: Disabled	Video BIOS Shadow	: Enabled
CPU Internal Cache	: Enabled	C8000-CBFFF Shadow	: Disabled
External Cache	: Enabled	CC000-CFFFF Shadow	: Disabled
Quick Power On Self Test	: Enabled	D0000-D3FFF Shadow	: Disabled
Hard Disk Boot From	: Pri-IDE	D4000-D7FFF Shadow	: Disabled
Boot Sequence	: C, A	D8000-DBFFF Shadow	: Disabled
Swap Floppy Drive	: Disabled	DC000-DFFFF Shadow	: Disabled
Boot Up Floppy Seek	: Disabled		
Floppy Disk Access Control	: R/W		
Boot Up NumLock Status	: On		
Boot Up System Speed	: High		
Typematic Rate Setting	: Disabled		
Typematic Rate (Chars/Sec)	: 6		
Typematic Delay (Msec)	: 250		
Security Option	: System	ESC : Quit	↑ ↓ → ← : Select
PCI / VGA Palett Snoop	: Disabled	F1 : Help	PU/PD/+/- : Mod
Assign PCI IRQ For VGA	: Disabled	F5 : Old Values	(Shift) F2 : Color
OS/2 Onboard Memory > 64MB	: Non-OS2	F6 : Load BIOS Defaults	
		F7 : Load Setup Defaults	

Virus Warning - When enabled, the BIOS will warn the user when any program attempts to write to or format the boot sector. If an attempt is made, the BIOS will halt the system and the following error message will appear:

You can accept or abort this operation.

Note: This feature is designed to guard against viruses that modify the boot sector on hard disks. However, many disk diagnostic programs which attempt to access the boot sector table, as well as partition and format programs, will also trigger this warning. If you will be running such a program, you can disable Virus Protection first, or choose "Y" to accept the boot sector modification when this message shows up.

<p>! WARNING ! Disk boot sector is to be modified Type "Y" to accept write or "N" to abort write Award Software, Inc.</p>

CPU Internal Cache - Enables or Disables the Level-1 Internal Cache memory. Generally, this would only be *Disabled* for troubleshooting purposes.

MAINBOARD BIOS SETUP

External Cache - Enables or Disables the Level-2 External Cache memory. Generally, this would only be *Disabled* for troubleshooting purposes.

Quick Power on Self Test - Speeds up Power On Self Test (POST) after the computer is powered on. When set to Enable, the BIOS will shorten or skip some checks during POST.

Hard Disk Boot From - This option lets you choose to boot from Primary IDE (Pri-IDE), Secondary IDE (Sec-IDE), or SCSI hard disk. Same as IDE options, the **Boot Sequence** in the next field is set to *C, A* when the *SCSI* is chosen.

Boot Sequence - When your system is powered on, the BIOS performs a variety of operations, then attempts to boot an Operating System from either a hard drive, floppy drive, or CD-ROM. This setting determines the sequence that the BIOS will follow when searching devices for a bootable disk. Most users find the *C, A* setting to be most beneficial, since it takes the least amount of time to boot the system. If however, you want the ability to boot from a Floppy or CD-ROM drive, you would need to choose either the *A, C* or *CDROM, C, A* setting. For instance, if your boot sequence was set to *C, A* and for some reason you wanted to boot to your Floppy A: Drive, it would not be possible, since the BIOS would always boot from the *C:* drive first. In this case, this setting would need to be changed to *A, C* so that the system would first check the floppy drive for a bootable disk. This would slow bootup speed, however, since the floppy would be checked on every boot.

C, A	System will first search hard disk drive then floppy disk drive for boot sector.
A,C	System will first search for boot sector on floppy disk, then hard disk.
CDROM, C, A	System will first search the CDROM drive, then hard disk drive and then floppy disk drive for boot sector.
C, CDROM, A	System will first search for boot sector on hard disk drive , then CDROM drive, and then floppy disk drive.

Swap Floppy Drive - The hardware connections determine which floppy is configured as drive A: and drive B: “Swapping” the floppy drives can be useful if your system has two floppy drives, and you want the ability to boot from both. For example: Since a PC cannot boot from the B: Floppy, you would need to “Swap” floppy drives A: and B: in order to set the second floppy drive to drive A:, thereby making it bootable.

Boot Up Floppy Seek - When enabled, BIOS will determine if the floppy disk drive installed is 40 or 80 tracks. It will display a warning if the floppy is Low Density (40 Trks).

Enabled	BIOS searches for floppy disk drive to determine if it is 40 or 80 tracks. Note that BIOS can not tell from 720K, 1.2M or 1.44M drive type as they are all 80 tracks.
Disabled	BIOS will not search for the type of floppy disk drive by track number. Note that there will not be any warning message if the drive installed is 360K.

Floppy Disk Access Control - When *R/W*, the floppy disk can be read and written. The other option is *Read Only*.

Boot Up NumLock Status - When *On*, the NumLock key will be automatically enabled when the system boots.

MAINBOARD BIOS SETUP

Boot Up System Speed - Sets the system speed to High or Low. Generally, low speed would only be used for troubleshooting purposes.

Typematic Rate Setting - Determines if the typematic rate is to be used. When disabled, continually holding down a key on your keyboard will generate only one instance. In other words, the BIOS will only report that the key is down. When the typematic rate is enabled, the BIOS will report as before, but it will then wait a moment, and, if the key is still down, it will begin to report that the key has been depressed repeatedly. This feature is used to accelerate cursor movements with the arrow keys.

Enabled	Enable typematic rate
Disabled	Disable typematic rate

Typematic Rate (Chars/Sec) - When the typematic rate is enabled, this selection allows you to select the rate at which the keys are accelerated. See the table to the right:

6	6 characters per second
8	8 characters per second
10	10 characters per second
12	12 characters per second
15	15 characters per second
20	20 characters per second
24	24 characters per second
30	30 characters per second

Typematic Delay (Msec) - When the typematic rate is enabled, this selection allows you to select the delay (in msec) between when the key was first depressed and when the acceleration begins.

Security Option - This option enables password checking every time the computer is powered on *or* every time BIOS Setup is executed. If *System* is chosen, a user password prompt appears every time the computer is turned on. If *Setup* is chosen, the password prompt appears only when the BIOS Setup program is executed. Refer to the section *Supervisor Password* for more information.

PCI / VGA Palette Snoop - This option must be set to *Enabled* if any ISA MPEG card installed requires VGA palette snooping. The settings are *Disabled* or *Enabled*.

Assign PCI IRQ For VGA - The *Enabled* option allows you to auto-route an IRQ for use by a PCI VGA card.

OS/2 Onboard Memory > 64MB - This should be set to **OS2** if you are running IBM OS/2 with more than 64MB of RAM in the system. Otherwise, the setting should be **Non-OS2**.

Video BIOS Shadow - This option controls the location of the contents of the 32KB of Video ROM beginning at the C0000h memory location. The settings are:

Enabled	The contents of C0000h-C7FFFh are written to the same address in system memory (RAM) for faster execution.
Disabled	The video ROM is not copied to RAM. The contents of the video ROM cannot be read from or written to cache memory.

C8000-DFFFF Shadow - These options control the location of the contents of the 16KB expansion card ROMs beginning at the specified memory location. If no adapter ROM is using the named ROM area, this area is made available to the local bus. Shadowing a ROM

MAINBOARD BIOS SETUP

reduces the memory available between 640KB and 1024KB by the amount used for this purpose. The settings are *Enabled* or *Disabled*.

CHIPSET FEATURES SETUP

This setup menu contains advanced configuration options relating to the mainboard chipset. These options are rarely changed by the user.

Auto Configuration	: Enabled	Singal Bit Error Report	: Enabled
DRAM Timing	: 60ns	Passive Release	: Enabled
DRAM Read Burst (EDO/FPM)	: x222/x333	Delayed Transaction	: Disabled
DRAM Write Burst Timing	: x333		
DRAM RAS# Precharge Time	: 3 HCLKs		
DRAM R/W Leadoff Timing	: 6/5 HCLKs		
Fast RAS# To CAS# Delay	: 3 HCLKs		
Turbo Read Leadoff	: Disabled		
DRAM Speculative Leadoff	: Disabled		
Turn-Around Insertion	: Disabled		
ISA Bus Clock	: PCI CLK/4		
Video BIOS Cacheable	: Enabled		
8 Bit I/O Recovery Time	: NA		
16 Bit I/O Recovery Time	: NA		
Memory Hole At 15M-16M	: Disabled	ESC : Quit	↑ ↓ → ← : Select
Peer Concurrency	: Enabled	F1 : Help	PU/PD/+/- : Mod
Chipset Special Features	: Enabled	F5 : Old Values	(Shift) F2 : Color
DRAM ECC / PARITY Select	: Parity	F6 : Load BIOS Defaults	
Memory Parity / ECC Check	: Disabled	F7 : Load Setup Defaults	

Auto Configuration - When **Enabled**, pre-defined values for DRAM, Cache, Timings, etc. are set according to the CPU type & system clock. *Enabled* is the recommended setting. These settings are only editable when Auto Configuration is *Disabled*.

Note: The first chipset settings deal with CPU access to dynamic random access memory (DRAM). The default timings have been carefully chosen and should only be altered if data is being lost. Such a scenario might occur if your system had mixed speed DRAM chips installed. Here, greater delays may be required to preserve the integrity of the data held in the slower memory chips.

DRAM Timing - DRAM timing is controlled by the DRAM timing registers. The timings programmed into this register are dependent on the system design. 60ns is the fastest rate. The 70ns timing is slower and may be required in certain system designs to support loose layouts or slower memory.

DRAM Read Burst (EDO/FPM) - Sets the burst mode read timing for two different DRAM types - (EDO/FPM). Burst read and write requests are generated by the CPU in four separate parts. The first part provides the location within the DRAM where the read or

MAINBOARD BIOS SETUP

write is to take place, while the remaining three parts provide the actual data. The lower the timing numbers, the faster the system will address memory. *x222/x333 *timings* is the default.

x222/x333	Read DRAM (EDO/FPM) timings are 2-2-2/3-3-3
x333/x444	Read DRAM (EDO/FPM) timings are 3-3-3/4-4-4
x444/x444	Read DRAM (EDO/FPM) timings are 4-4-4/4-4-4

DRAM Write Burst Timing - Sets the timing for burst mode writes from DRAM. Burst read and write requests are generated by the CPU in four separate parts. The first part provides the location within the DRAM where the read or write is to take place, while the remaining three parts provide the actual data. The lower the timing numbers, the faster the system will address memory. *x333 *timings* is the default.

x222	Write DRAM timings are 2-2-2-2
x333	Write DRAM timings are 3-3-3-3
x444	Write DRAM timings are 4-4-4-4

DRAM RAS# Precharge Time - DRAM must continually be refreshed or it will lose its data. Normally, DRAM is refreshed entirely as the result of a single request. This option allows you to determine the number of CPU clocks allocated for the **Row Address Strobe** to accumulate its charge before the DRAM is refreshed. If insufficient time is allowed, refresh may be incomplete and data will be lost. Options are **3** or **4** Clocks. *Default = *3 CPU Clocks*.

DRAM R/W Leadoff Timing - Sets the number of CPU clocks allowed before reads and writes to DRAM are performed. **6 CPU Clocks* is the default.

Fast RAS# to CAS# Delay - The DRAM row miss leadoff timing is controlled by this option. This setup item allows you to determine the timing of the transition from Row Address Strobe (RAS) to Column Address Strobe (CAS). Options are **2** or **3** Clocks delay. **3 CPU clocks* is the default.

Turbo Read Leadoff - The turbo read leadoff may be required in certain system designs to support layouts or faster memories. **Disabled* is the default.

DRAM Speculative Leadoff - The Triton II chipset is capable of allowing a DRAM read request to be generated slightly before the address has been fully decoded. This can reduce all read latencies. More simply, the CPU will issue a read request and included with this request is the place (address) in memory where the desired data is to be found. This request is received by the DRAM controller. When the 'Speculative Leadoff' is enabled, the controller will issue the read command slightly before it has finished determining the address. **Disabled* is the default.

MAINBOARD BIOS SETUP

Turn-Around Insertion - When **Enabled**, the chipset will insert one extra clock to the turn-around of back-to-back DRAM cycles. **Disabled* is the default.

ISA Bus Clock - This item allows you to select the PCI clock type. PCI CLK/3 or PCI CLK/4.

Video BIOS Cacheable - When **Enabled**, the Video BIOS cacheable will cause access to the video BIOS addressed at C0000H to C7FFFH to be cached. **Enabled* is the default.

8 Bit I/O Recovery Time - The recovery time is the length of time, measured in CPU clocks, that the system will delay after the completion of an input/output request. This delay takes place because the CPU is operating faster than the input/output bus. Therefore the CPU must be delayed to allow for the completion of I/O transfers. This item allows you to determine the recovery time allowed for 8 bit I/O. Choices are from NA, 1 to 8 CPU clocks. **NA* is the default.

16 Bit I/O Recovery Time - This item allows you to determine the recovery time allowed for 16 bit I/O. Choices are from NA, 1 to 4 CPU clocks. **NA* is the default.

Memory Hole At 15M-16M - In order to improve performance, certain space in memory can be reserved for ISA cards. This memory must be mapped into the memory space below 16 MB. **Disabled* is the default.

Peer Concurrency - Peer concurrency means that more than one PCI device can be active at a time. **Enabled* is the default.

Chipset Special Features - When **Disabled**, the chipset behaves like an earlier version. (Used mainly for Troubleshooting).

DRAM ECC/PARITY Select - Select between two methods of DRAM error checking, ECC and Parity (*default*).

Memory Parity / ECC Check - Allows you to select between three methods of memory error checking: **Auto**, **Enabled** and **Disabled**.

Single Bit Error Report - When **Enabled**, if a single bit error is detected, the offending DRAM row ID is latched. The latched Value is held until the software explicitly clears the error status flag.

Passive Release - The PIIX3 (PCI ISA IDE Xcelerator) provides a programmable Passive Release mechanism to meet the required master latencies. When *enabled* (default), ISA masters may see long delays in access to any PCI memory, including the main DRAM array.

Delayed Transaction - It is used by targets that cannot complete the initial data phase within the requirements of the PCI 2.1 specification. *Disabled* is the default.

MAINBOARD BIOS SETUP

POWER MANAGEMENT SETUP

This menu contains configuration options that reduce power consumption when the system is not in use. Other “Green-PC” compliant peripherals are also supported. Power Management allows you to configure you system to use energy most efficiently, and yet still in a manner consistent with your own style of computer use.

Power Management	: User Defined	** Power Down & Resume Events **
PM Control by APM	: Yes	IRQ3 (COM 2) : OFF
Video Off Method	: V/H SYNC+Blank	IRQ4 (COM 1) : ON
Video Off Option	: Susp, Stby -> Off	IRQ5 (LPT 2) : ON
Suspend Switch	: Enabled	IRQ6 (Floppy Disk) : ON
MODEM Use IRQ	: 3	IRQ7 (LPT 1) : ON
		IRQ8 (RTC Alarm) : OFF
Doze Mode	: Disabled	IRQ9 (IRQ2 Redir) : ON
Standby Mode	: Disabled	IRQ10 (Reserved) : ON
Suspend Mode	: Disabled	IRQ11 (Reserved) : ON
HDD Power Down	: Disabled	IRQ12 (PS/2 Mouse) : ON
		IRQ13 (Coprocessor) : ON
** Wake Up Events In Doze & Standby **		IRQ14 (Hard Disk) : ON
IRQ3 (Wake - Up Event)	: OFF	IRQ15 (Reserved) : ON
IRQ4 (Wake - Up Event)	: ON	ESC : Quit ↑ ↓ → ← : Select Item
IRQ8 (Wake - Up Event)	: OFF	F1 : Help PU/PD/+/- : Modify
IRQ12 (Wake - Up Event)	: ON	F5 : Old Values (Shift) F2 : Color
		F6 : Load BIOS Defaults
		F7 : Load Setup Defaults

Power Management - This category allows you to select the type (or degree) of power saving and is directly related to the following modes: Doze Mode, Standby Mode, Suspend Mode and HDD Power Down. There are four selections for Power Management, three of which have fixed mode settings:

Disabled (default)	No power management. Disables all four modes
Min. Saving	Minimum power management. Doze Mode = 1 hr. Standby Mode = 1 hr., Suspend Mode = 1 hr., and HDD Power Down = 15 min.
Max. Saving	Maximum power management -- ONLY AVAILABLE FOR SL CPUs. Doze Mode = 1 min., Standby Mode = 1 min., Suspend Mode = 1 min., and HDD Power Down = 1 min.
User Defined	Set each mode individually. When Enabled, each range is from 1 min. to 1 hr., except for HDD Power Down which ranges from 1 min. to 15 min.

PM Control by APM - When Enabled, an Advanced Power Management device will be activated to enhance the Max. Power Saving mode and stop the CPU internal clock. If the Max. Power Saving is not enabled, this will be preset to *No*.

Video Off Method - This determines the manner in which the monitor is blanked.

MAINBOARD BIOS SETUP

V/H YNC+Blank	This selection will cause the system to turn off the vertical and horizontal synchronization ports, writing blanks to the video buffer.
Blank Screen	This option only writes blanks to the video buffer.
DPMS	Initial display power management signaling.

Video Off Option - This is to determine when to activate the video off function. Options are: “Susp, Stby - Off” (default), “All Modes -> Off”, and “Always On”.

Suspend Switch - Enables or Disables the SMI connector on the mainboard. (See page 12) When *Enabled*, a switch on the computer case can be used to trigger power saving functions.

MODEM Use IRQ - This setting tells the BIOS which IRQ the modem is using, so that any activity on that interrupt can bring the system out of power saving mode. Options are: NA, 3 (default), 4, 5, 7, 9, 10, 11.

PM Timers - The following four modes are Green PC power saving functions which are only user configurable when *User Defined* Power Management has been selected. See above for available selections.

Doze Mode - When enabled and after the set time of system inactivity, the CPU clock will run at slower speed while all other devices still operate at full speed.

Standby Mode - When enabled and after the set time of system inactivity, the fixed disk drive and the video will be shut off while all other devices still operate at full speed.

Suspend Mode - When enabled and after the set time of system inactivity, all devices except the CPU will be shut off.

HDD Power Down - When enabled and after the set time of system inactivity, the hard disk drive will be powered down while all other devices remain active.

Wake Up Events in Doze & Standby - When set to **ON**, any activity on the specified IRQ will cause the system to “wake up” from Doze or Standby mode. The **OFF** setting disables wake up for the specified IRQ.

Power Down & Resume Events - Power Down and Resume events are I/O events whose occurrence can prevent the system from entering a power saving mode or can awaken the system from such a mode. In effect, the system remains alert for anything which occurs to a device which is configured as *On*, even when the system is in a power down mode.

When an I/O device wants to gain the attention of the operating system, it signals this by causing an IRQ to occur. When the operating system is ready to respond to the request, it interrupts itself and performs the service. As above, the choices are *On* and *Off*. *Off* is the default. When set *On*, activity will neither prevent the system from going into a power management mode nor awaken it.

MAINBOARD BIOS SETUP

You can set IRQ3 - 15 individually. Activity detected from any enabled IRQ channel will wake up the system.

PNP/PCI CONFIGURATION SETUP

The PCI **P**ersonal **C**omponent Interconnect Bus was developed by Intel and other industry leader partners primarily to address two important issues faced by PC hardware designers today: a) How to allow peripheral devices to take the fullest advantage of the power of Pentium and Pentium Pro chip technology, and b) Provide a simpler installation process for peripheral devices, such as Network cards, EIDE or SCSI controllers.

PCI accomplishes these goals with its 32-bit Data path Local Bus design, and support for Plug & Play. Unlike older expansion bus architectures, PCI provides peripherals with a direct connection to the CPU and memory. The PCI bus runs at 33Mhz and has a maximum transfer capability of 132MBps. With Plug & Play, the system BIOS automatically determines hardware resources for new peripherals, simplifying installation of multiple interface cards.

This Setup Menu provides configuration options for the PCI Bus and its assigned resources.

Resources Controlled by	: Manual	PCI IRQ Activated By	: Level
Reset Configuration Data	: Disabled	PCI IDE IRQ Map To	: PCI-AUTO
IRQ-3 assigned to	: Legacy ISA	Primary IDE INT#	: A
IRQ-4 assigned to	: Legacy ISA	Secondary IDE INT#	: B
IRQ-5 assigned to	: PCI/ISA PnP	Onboard SCSI Chip	: Enabled
IRQ-7 assigned to	: PCI/ISA PnP	PCI Latency Timer	: 80 PCI Clocks
IRQ-9 assigned to	: PCI/ISA PnP		
IRQ-10 assigned to	: PCI/ISA PnP		
IRQ-11 assigned to	: PCI/ISA PnP		
IRQ-12 assigned to	: PCI/ISA PnP		
IRQ-14 assigned to	: Legacy ISA		
IRQ-15 assigned to	: Legacy ISA		
DMA-0 assigned to	: PCI/ISA PnP		
DMA-1 assigned to	: PCI/ISA PnP	ESC : Quit	↑ ↓ → ← : Select Item
DMA-3 assigned to	: PCI/ISA PnP	F1 : Help	PU/PD/+/- : Modify
DMA-5 assigned to	: PCI/ISA PnP	F5 : Old Values (Shift)	F2 : Color
DMA-6 assigned to	: PCI/ISA PnP	F6 : Load BIOS Defaults	
DMA-7 assigned to	: PCI/ISA PnP	F7 : Load Setup Defaults	

Resources Controlled By - The Award Plug and Play BIOS has the capacity to automatically configure all of the boot and Plug and Play compatible devices. This capability is specifically designed for a Plug and Play operating system such as Windows[®] 95. Choices are *Auto* (default) and *Manual*.

MAINBOARD BIOS SETUP

Reset Configuration Data - Reset Configuration Data: When set to Enabled, ESCD (Extended System Configuration Data) is cleared. This setting will automatically be set back to Disabled when the system reboots. *Enabled* and *Disabled* (default).

IRQ3/4/5/7/9/10/11/12/14/15, DMA0/1/3/5/6/7 assigned to - By default, all resources are assigned to the PCI Bus except IRQs 3 and 4. If an ISA card requires a particular IRQ or DMA channel, those resources should be set to Legacy ISA so that the PCI Bus will not try to use them. Choices are *Legacy ISA* and *PCI/ISA PnP*.

PCI IRQ Activated By - This sets the method by which the PCI bus recognizes that an IRQ service is being requested by a device. Under all circumstances, you should retain the default configuration unless advised otherwise by your system's manufacturer. Choices are *Level* (default) and *Edge*.

PCI IDE IRQ Map To - Configures what type of IDE disk controller is in use. By default, Setup assumes that you are using the on-board PCI IDE Controller and this option is set to **PCI-AUTO**. If you have equipped your system with an add-on PCI controller, changing this setting allows you to specify which slot has the controller and which PCI interrupt (A, B, C or D) is associated with the Primary and/or Secondary port. Most add-on IDE controllers are configured to use INT# A for the primary and INT# B for the secondary.

Onboard SCSI Chip - Enables or Disables the Onboard SCSI Controller and the SCSI BIOS.

PCI Latency Timer - This option sets latency of all PCI devices on the PCI bus. The settings are in units equal to PCI clocks. Available settings are 0 ~ 248. The default is 80.

LOAD BIOS DEFAULTS

Loads "Fail Safe" settings into the BIOS Setup program. These options are designed to slow the system down for troubleshooting purposes. To load the default values, highlight this option and press [ENTER]. Enter "Y" in the confirmation screen and press [ENTER] again. User-defined options in the **Standard CMOS Setup** are not affected.

LOAD SETUP DEFAULTS

Loads the default values for best system performance into the BIOS Setup program. To load the default values, highlight this option and press [ENTER]. Enter "Y" in the confirmation screen and press [ENTER] again. User-defined options in the **Standard CMOS Setup** are not affected.

MAINBOARD BIOS SETUP

INTEGRATED PERIPHERALS SETUP

This menu is used to configure the integrated IDE subsystem and other peripherals.

IDE HDD Block Mode	: Enabled	
Onboard Primary PCI IDE	: Enabled	
IDE Primary Master PIO	: Auto	
IDE Primary Slave PIO	: Auto	
Onboard Secondary PCI IDE	: Enabled	
IDE Secondary Master PIO	: Auto	
IDE Secondary Slave PIO	: Auto	
PCI Slot IDE 2nd Channel	: Disabled	
USB Controller	: Disabled	
On-board FDC Controller	: Enabled	
On-board Serial Port 1	: COM1/3F8	
On-board Serial Port 2	: COM2/2F8	
On-board Parallel Port	: 378/IRQ7	
Parallel Port Mode	: Normal	
InfraRed/COM2 Selected	: UART COM2	ESC: Quit ↑↓→←: Select F1 : Help PU/PD/+/- : Modify F5 : Old Values (Shift) F2: Color F6 : Load BIOS Defaults F7 : Load Setup Defaults

IDE HDD Block Mode

This allows your hard disk controller to use fast block mode to transfer data to and from your hard disk drive (HDD). **Enabled** or **Disabled**. *Enabled* is the default.

PIO Mode - IDE Programmed I/O Mode - This setting relates to the speed at which the hard drive is able to transfer data, up to 16.6MB/second for Mode 4 drives. Available settings are *Auto*, *0*, *1*, *2*, *3*, or *4*. As with the **Type** setting, *Auto* is the preferred choice, in that the supported PIO Mode is read directly from the hard drive. Be sure not to enter in a PIO Mode Setting that is higher than what the drive actually supports. This will probably result in loss of data.

- The relation between the IDE PIO mode value and IDE cycle timing is shown in the following table:

PIO Mode	Timing
0	600 ns
1	383 ns
2	240 ns
3	180 ns
4	120 ns

MAINBOARD BIOS SETUP

Onboard Primary PCI IDE - Enables or Disables the primary controller. Situations where this controller would be disabled are: a) *You are not using any IDE Drives* or b) *You are using an add-on IDE controller in a PCI Slot.*

Enabled	Primary onboard HDD controller used -- Default
Disabled	Primary onboard HDD controller not used.

Onboard Secondary PCI IDE - Enables or Disables the secondary controller. Situations where this controller would be disabled are: a) *You are not using any IDE Drives* or b) *You are using IDE Drives ONLY on the primary controller* or c) *You are using an add-on IDE controller in a PCI Slot.*

Enabled	Secondary onboard HDD controller used
Disabled	Secondary onboard HDD controller not used.

PCI Slot IDE 2nd Channel - Allows you designate an IDE controller board inserted into one of the PCI slots as your secondary IDE controller. **Disabled* default.

USB Controller - Enables or Disables the on-board USB (Universal Serial Bus) controller.

Onboard FDC Controller - Enables or Disables the on-board Floppy Disk Controller.

Onboard Serial Port 1 - With this option, the on-board Serial Port 1 can be Disabled, or set to COM1/3F8 (*Default), COM2/2F8, COM3/3E8 or COM4/2E8.

Onboard Serial Port 2 - With this option, the on-board Serial Port 2 can be Disabled, or set to COM2/2F8 (*Default), COM1/3F8, COM3/3E8 or COM4/2E8.

Onboard Parallel Port - With this option, the on-board Parallel Port can be Disabled, or set to 378/IRQ7 (*Default), 3BC/IRQ7 or 278/IRQ5.

Parallel Port Mode - Sets the operating mode of the parallel port. Options are: *Normal, EPP/Normal, ECP* and *ECP/EPP*.

ECP Mode Use DMA - Options are 1 and 3. This field is available only when one of the two following options in **Parallel Port Mode** is selected: *ECP* or *ECP/EPP*.

EPP Version - Options are 1.7 (default) and 1.9 (IEEE 1284 compliant).

InfraRed /COM2 Selected - By default, this field is set to **UART COM2**, which directs the second serial port UART to support the COM2 serial port. Choosing **IrDA SIR** or **SHARP IR** will activate the on-board infrared feature and redirect the second serial port UART to support the infrared module connector on the mainboard.

MAINBOARD BIOS SETUP

SUPERVISOR PASSWORD AND USER PASSWORD SETTING

Passwords can be set to provide protection for the BIOS configuration options, or to restrict access to the computer itself.

When enabled, *User Password* will require all users to enter a password in order to use the system, and/or enter the BIOS setup (but can't change its contents). A *Supervisor Password* is used to protect the stored CMOS options from being changed by unauthorized users.

Keep in mind that when set, a password is required only when *booting* the system. It will not provide protection to a system that is already booted.

The password check option is set in **BIOS FEATURES SETUP** by choosing either *System* (the password prompt appears every time the system is powered on) or *Setup* (the password prompt appears only when the user enters the BIOS Setup). The password is stored in CMOS RAM, and can be cleared with the *Clear CMOS Jumper*.

To set a password:

1. You must first set the *Supervisor* password by choosing *Supervisor Password* and pressing [ENTER]. Setup prompts for a password.
2. Enter a 1-8 character password using letters, numbers, or a combination of both. The specific characters are not shown as you enter them. Press [ENTER].
3. A confirmation box appears asking you to re-enter the password. Enter the password again. Press [ENTER]. Follow the same procedure to set the *User Password*.

Changing a Password:

1. Select the appropriate password option (Supervisor or User) from the main menu and press [ENTER]. Enter the current password and press [Enter]. The screen does not display the characters entered. Enter in the new password, then the confirmation. You cannot change the current password unless you know it.

Erasing a Password:

1. If you know the current password, but want to disable password checking, follow the procedure for changing the password. When Setup prompts for the new password, simply press [ENTER]. You will see a message indicating that the password is disabled.
2. If you do not know the current password, the CMOS must be cleared via the *Clear CMOS Jumper*, JP3 (See page 10). *This will clear all user-defined BIOS Setup options.

MAINBOARD BIOS SETUP

IDE HDD AUTO DETECTION

Automatically detect and configure hard disk parameters. The Award BIOS includes this ability in the event you are uncertain of your hard disk's parameters. See also "Standard CMOS Setup".

SAVE & EXIT SETUP / EXIT WITHOUT SAVING

Select *Save & Exit Setup* to save into the CMOS memory all modifications specified during the current session. To save the configuration changes, highlight this option in the main menu and press [ENTER]. The system displays a confirmation message on the screen. Press the "Y" key and then [Enter]. Press the "N" key and then the [Enter] key to abort. The *Exit Without Saving* option allows the user to exit the BIOS Setup without updating any changes made during the current session.

PCI Device Listing

This list of installed PCI devices appears after the **System Configuration** screen:

PCI device listing						
Bus No.	Device No.	Func No.	Vender ID	Device ID	Device Class	IRQ
0	7	1	8086	7010	IDE Controller	
14/15						
0	7	2	8086	8829	Serial bus controller	
11						
0	9	0	1013	7333	Display controller	
NA						

- Bus No. Encoded value indicating 1 of 256 possible buses in a system.
- Device No. Encoded value indicating 1 of 32 possible devices on a given bus.
- Func No. Encoded value indicating 1 of 8 possible functions on a multifunction device.
- Vender ID Identifies the manufacturer of the device. Valid vendor identifiers are allocated by the PCI SIG (Special Interest Group) to ensure uniqueness.
- Device ID Identifies the particular device. This identifier is allocated by the vendor.
- Device Class Specifies one of the following device classes: Mass storage controller, Network controller, Display controller, Multimedia device, Bridge device, Simple communication controller, Base system peripherals, Input device, Docking station, Processor and Serial bus controller.

MAINBOARD BIOS SETUP

The PCI device listing is useful for troubleshooting purposes. More detailed information for each field may be obtained through the PCI specification documentation.

This mainboard supports the **Desktop Management Interface (DMI)**, which is a new method of providing enterprise management for personal computers. The main component of DMI is the Management Information Format Database (MIF), which contains information about the computer system and its components, such as BIOS version/vendor, CPU speed/type, memory size/type, L1/L2 cache, port connectors (IDE, floppy, 2S/1P, USB, keyboard, mouse,), slots ... etc. Using DMI, remote PC management software is able to obtain various information about the system, including hardware profiles, capabilities, operational status, installation dates, and other information about the system and its components.

This DMI utility, DMICFG.EXE, allows you to add additional information, such as serial numbers, vendor information, and enclosure/chassis configurations, into the MIF.

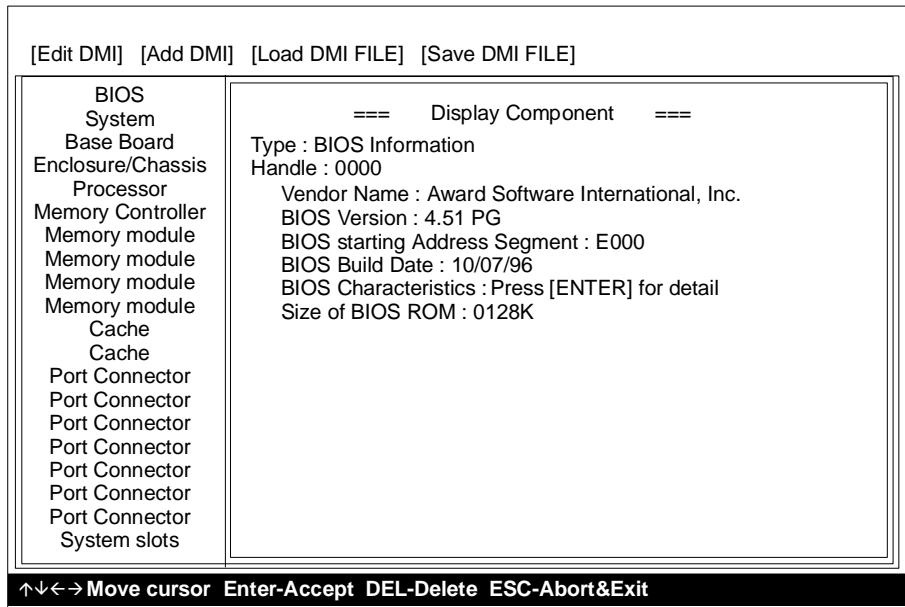

Note: The DMI utility must be run in real mode without the EMM386 memory manager loaded.

FLASH BIOS PROGRAMMING UTILITY

Updating the Award BIOS Code is made easy with the AWDFLASH Utility. Since this motherboard features FLASH BIOS, it is not necessary to change the actual BIOS chip in order to upgrade the System BIOS. The user can simply re-program the old BIOS using the AWDFLASH Utility as follows:

1. First, boot the system with DOS or to “Safe Mode” under Windows 95. If you are booting DOS from a hard drive or floppy disk, press [F5] when the message “Starting MS-DOS...” appears on the screen. If you are booting Windows 95, press the [F8] key, and select the “Safe mode command prompt” option. This will assure that the system is running in “*real mode*” with **no device drivers loaded**. *This is the only correct way to run the AWDFLASH Utility program.*
2. There are (2) important files needed to re-program the BIOS. The first is “AWDFLASH.EXE” which is the FLASH BIOS Programming Utility. The second file needed is the updated “BIN” file which contains the actual BIOS code. This file will have the extension [.bin], such as “P598GH.BIN”. Make sure these files are on the diskette or hard drive in the same directory.
3. Start the AWDFLASH Utility by changing to the directory where the two required files exist and typing: AWDFLASH and pressing [ENTER].
4. The AWDFLASH Utility Screen appears. You will be asked for the file name to program. Type in the name of the new BIOS (.bin) file and hit [ENTER].

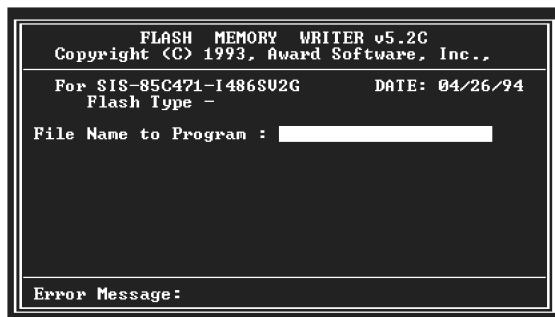

5. The program will then ask if you want to backup the old BIOS. This is recommended in case there are any problems with the new “.bin” file. Enter the name of the new backup file (such as “backup.bin”) and press [ENTER].
6. At this time the system will prompt you for final confirmation before beginning programming. The Utility can be aborted at this time by hitting “n”. To begin programming, hit “y”...
7. When the Flash programming starts, a bar indicator will show the progress of the programming operation. After successful completion, hit the reset button or power off the computer.

ADAPTEC® SCSISelect™ UTILITY

The **Adaptec SCSISelect Utility** provides the user with a convenient way to configure the on-board SCSI controller's BIOS and the attached devices, performing a function similar to the Mainboard BIOS Setup program.

There will be slight differences in the *SCSISelect* Utility depending on which mainboard you are using. The following table shows the differences in the P5H30-NS and P5H30-WS mainboards as they relate to the *SCSISelect* Utility:

Mainboard	Chip	Devices Supported	Maximum Xfer Rate
P5H30-NS	AIC-7860	(7) SCSI-2 or Ultra SCSI	20MB/Sec
P5H30-WS	AIC-7880	(15) SCSI-2, Wide SCSI-2, Ultra-SCSI or Ultra-Wide SCSI	40MB/Sec

- The type of chip that your mainboard features will be shown at the top of the *SCSISelect* Utility Screen.

Once the on-board SCSI controller is enabled in the Mainboard BIOS Setup, the SCSI BIOS becomes active, and the user can enter the *SCSISelect* Utility by pressing **Ctrl+A** when the BIOS banner is displayed as shown to the right:

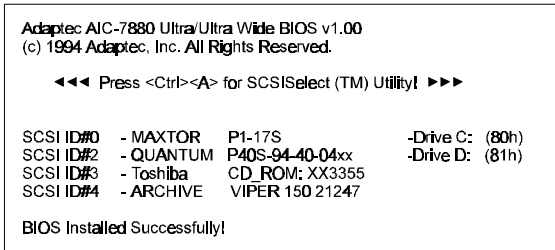

SCSISelect Utility Main Menu Options - Upon entering the Utility, the main menu screen is displayed:

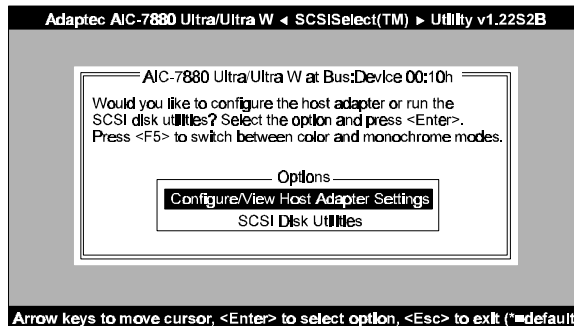

Press [ENTER] to choose the *Configure/View Host Adapter Settings* menu.

ADAPTEC® SCSISelect™ UTILITY

Configure / View On-board Host Adapter Settings Menu

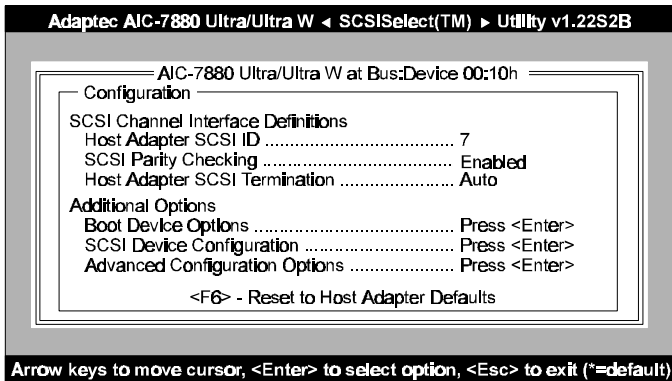

Note: Pressing **F6** will reset all settings to the host adapter defaults. Host adapter default settings are marked with an asterisk (*) throughout the selection submenus.

Host Adapter SCSI ID - This option allows you to change the host adapter SCSI ID. There are (16) available IDs for the AIC-7880 Ultra-Wide controller, (8) for the AIC-7860. The default setting for both models is SCSI ID 7, which has the highest priority on the SCSI bus. (We recommend that you do not change this setting).

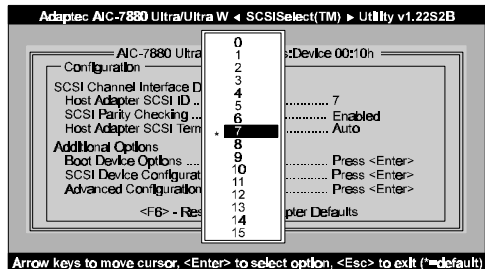

Each SCSI device on the SCSI bus, including the host adapter, must be set to a unique SCSI ID. The SCSI ID serves two purposes: it uniquely identifies each SCSI device on the bus, and it determines the device's priority on the bus during the Arbitration phase. The Arbitration phase determines which device controls the bus when two or more devices request use of it.

When selecting the host adapter SCSI ID, consider the following:

- If you install more than one SCSI host adapter in the computer, each board has its own SCSI bus. This means devices can have duplicate SCSI IDs, as long as they are not on the same SCSI bus (e. g. each SCSI bus can have a device with SCSI ID 0, etc.).
- If you plan to connect two host adapters in two different computers to the same SCSI bus so they can share SCSI devices, set the host adapters to different SCSI IDs. IDs 6 and 7 are preferable, since they have the highest priority on the SCSI bus.

ADAPTEC® SCSISelect™ UTILITY

SCSI Parity Checking - Select this option to enable or disable SCSI Parity Checking on the host adapter. The default setting is *Enabled*.

The host adapter always checks parity when reading from the SCSI bus to verify the correct transmission from your SCSI devices. You should disable SCSI Parity Checking if any attached SCSI devices do not support SCSI parity. (Most currently available SCSI devices do support SCSI parity.)

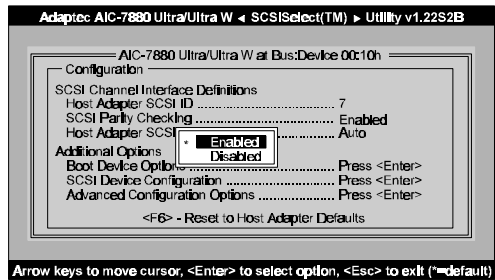

Host Adapter SCSI Termination

This option allows you to configure host adapter SCSI termination. Both ends of the SCSI bus should be terminated. Host Adapter termination should be disabled if you attach SCSI devices to both internal and external connectors since the host adapter would then be in the middle of the SCSI bus. The P5H30-NS/WS Mainboard is equipped with an Active Terminator that will automatically switch from Enabled to Disabled or vice versa by scanning the devices mounted on the SCSI bus. So, manual termination is not required.

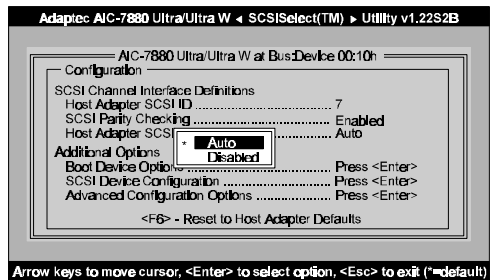

Boot Device Configuration

Boot Target ID and Boot LUN Number - let you specify the boot device. The default boot device is the device at SCSI ID 0 and logical unit number (LUN) 0. To specify a different boot device, choose a different SCSI ID: ID 0 through 7 on the 8-bit cable, or ID 0 through 15 on the 16-bit cable. If the boot device has multiple logical units, you must also specify the boot LUN, which can be 0 through 7 (on 8-bit or 16-bit adapters).

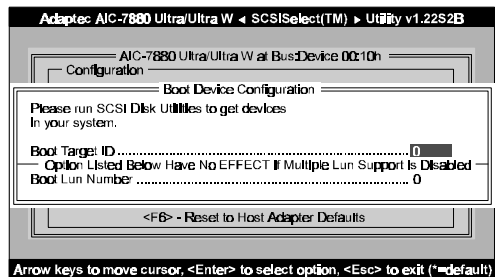

ADAPTEC® SCSISelect™ UTILITY

SCSI Device Configuration - This option allows you to configure certain parameters of each SCSI device on the SCSI bus. The screen shows a column of information for each SCSI ID, even if some SCSI IDs are not assigned to a device.

SCSI Device Configuration								
SCSI Device ID	#0	#1	#2	#3	#4	#5	#6	#7
Initiate Sync Negotiation	yes	yes	yes	yes	yes	yes	yes	yes
Maximum Sync Transfer Rate ..	20.0	20.0	20.0	20.0	20.0	20.0	20.0	20.0
Enable Disconnection	yes	yes	yes	yes	yes	yes	yes	yes
Initiate Wide Negotiation	yes	yes	yes	yes	yes	yes	yes	yes
Options Listed Below Have NO EFFECT if the BIOS is Disabled								
Send Start Unit Command	no	no	no	no	no	no	no	no

SCSI Device Configuration								
SCSI Device ID	#8	#9	#10	#11	#12	#13	#14	#15
Initiate Sync Negotiation	yes	yes	yes	yes	yes	yes	yes	yes
Maximum Sync Transfer Rate ..	20.0	20.0	20.0	20.0	20.0	20.0	20.0	20.0
Enable Disconnection	yes	yes	yes	yes	yes	yes	yes	yes
Initiate Wide Negotiation	yes	yes	yes	yes	yes	yes	yes	yes
Options Listed Below Have NO EFFECT if the BIOS is Disabled								
Send Start Unit Command	no	no	no	no	no	no	no	no

Initiate Sync Negotiation - This option determines whether the host adapter initiates synchronous negotiation with the SCSI device. When set to yes, the host adapter initiates synchronous negotiation with the SCSI device. When set to no, the host adapter does not initiate synchronous negotiation. The host adapter, however, always responds to synchronous negotiation if the SCSI device initiates it. The default setting is yes.

Data is transferred in asynchronous mode if neither the on board SCSI nor the SCSI peripheral negotiates for synchronous data transfers.

Note: Some older SCSI-1 devices do not support synchronous negotiation. This may cause your computer to operate erratically or hang if Initiate Sync Negotiation is enabled. Set Initiate Sync Negotiation to no for these devices.

Maximum Sync Transfer Rate - This option determines the maximum data transfer rate that the host adapter will use for a particular device. The default value is 20.0. The P5H30-WS mainboard provides a 16-bit (2-byte) channel that supports an effective maximum synchronous transfer rate of 40.0 MBytes/sec. (20.0 Mbytes per 8-bit channel). Valid setting are:

SCSISelect Transfer Rate	8-Bit Connector	16-Bit Connector
	Effective Transfer rate	Effective Transfer Rate
20.0	20.0 MBytes/Sec.	40.0 MBytes/Sec
16.0	16.0 MBytes/Sec.	32.0 MBytes/Sec
13.4	13.4 MBytes/Sec.	26.8 MBytes/Sec
10.0	10.0 MBytes/Sec.	20.0 MBytes/Sec

In most cases, you can use the maximum value of 20.0. If the host adapter is set not to negotiate for synchronous data transfer (i.e., *Initiate Sync Negotiation* is set to no) then the value selected here is the maximum rate that the host adapter accepts from the device during negotiation. (This is standard SCSI protocol.)

Enable Disconnection - This option determines whether the host adapter allows a SCSI device to disconnect from the SCSI bus (sometimes called Disconnect/ Reconnect). Disconnect/Reconnect allows the host adapter to perform other operations on the SCSI bus while the SCSI device is temporarily disconnected.

When set to **yes**, the SCSI device may disconnect from the SCSI bus. The SCSI device, however, may choose not to disconnect, even if permitted by the host adapter (this can usually be configured on the SCSI device).

When set to **no**, the SCSI device is not allowed to disconnect from the SCSI bus. The default setting is **yes**. You should leave Enable Disconnection set to yes if two or more SCSI devices are connected to the on board SCSI port. This optimizes SCSI bus performance. If only one SCSI device is connected to the SCSI port, set Enable Disconnection to **no** to achieve slightly better performance.

Send Start Unit Command - This option, which is supported by some SCSI devices, determines whether the Start Unit Command (SCSI command 1B) is sent to the SCSI device (most devices do not require this). Enabling this option reduces the load on your computer's power supply by allowing the host adapter to power-up SCSI devices one-at-a-time when you boot your computer. Otherwise, the devices all power-up at the same time. Most devices require you to set a jumper before they can respond to this command.

When set to **yes**, the Start Unit Command is sent to the SCSI device during bootup. When set to **no**, each SCSI device powers-up in its normal fashion. The default setting is **no**.

Note: The Send Start Unit Command setting is valid only if the host adapter BIOS is enabled.

If this option is enabled for more than one SCSI device, the Start Unit Command is sent first to the device with the lowest SCSI ID. When this device responds to the host adapter, the Start Unit Command is sent to the next highest SCSI ID with a setting of yes. The process continues until all supported devices responds to the host adapter.

Note: If many drives are set to yes for Send Start Unit Command, the boot time will vary depending on how long it takes each drive to spin up.

Initiate Wide Negotiation - This option, which appears for only 16-bit adapters, lets the adapter initiate wide negotiation with a 16-bit SCSI device. The adapter will not attempt wide negotiation with 8-bit devices, so you can leave this option enabled (that is, set to yes) even if the bus includes 8-bit devices.

ADAPTEC® SCSISelect™ UTILITY

Advanced Configuration Options - Do not change these five options unless absolutely necessary.

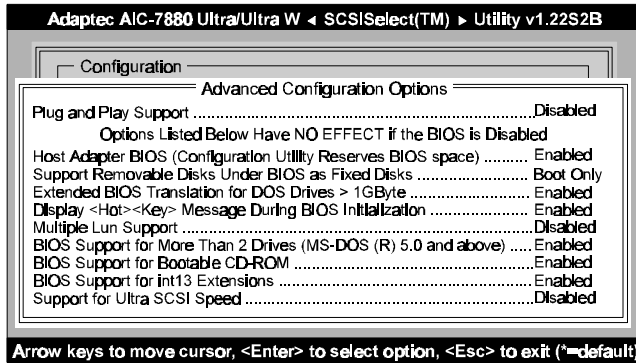

Plug and Play Support - This option appears only if the BIOS is configured to include SCAM-1 support. When enabled, the option allows the adapter to automatically assign a SCSI ID to an attached SCSI device that supports SCAM-1 protocol. Most non-SCAM devices tolerate SCAM protocol, so you can usually enable this option even if you have some non-SCAM devices. In rare cases an old SCSI-1 device may not tolerate SCAM and may cause the computer to hang or operate erratically. If this happens, leave this option disabled.

Host Adapter BIOS - This setting Enables or Disables the AIC-78x0 BIOS. The BIOS must be enabled if you want the computer to boot from a SCSI hard disk drive connected to the adapter. In addition, the BIOS must be enabled if you want to enable any of the following options:

- Support Removable Disks Under BIOS as Fixed Disks
- Extended BIOS Translation for DOS Drives > 1 Gbyte
- Display <Ctrl> <A> Message During BIOS Initialization
- Multiple Lun support
- BIOS Support for More Than 2 Drives
- BIOS Support for Bootable CD-ROM
- BIOS Support for Int 13h Extensions
- Support for Ultra Speed
- Send Start Unit SCSI Command

If the devices on the SCSI bus are controlled by device drivers, you can disable the SCSI BIOS and free 16 Kbytes of memory. This also shortens the boot time by up to 60 seconds.

ADAPTEC® SCSISelect™ UTILITY

Support Removable Disk Under BIOS as Fixed Disks - This option allows you to control which removable-media drives are supported by the AIC-78x0 BIOS. It is only valid if the AIC-78x0 BIOS is enabled. The default setting is *Boot Only*. The following choices are available:

- **Boot Only** - Only the removable-media drive designated as the boot device are treated as a hard disk drive.
- **All Disks** - All removable - media drives supported by the BIOS are treated as hard disk drives.
- **Disabled** - No removable-media drives are treated as hard disk drives In this situation, software drives are needed because the drive(s) are not controlled by the BIOS.

Caution: Support for removable media drives means that the host adapter BIOS allows you to use a removable media drive only as if it were a hard disk drive; you cannot remove the disk media during operation. If a removable media SCSI device is controlled by the host adapter BIOS, do not remove the media while the drive is powered-on or you may lose data. If you want to be able to remove media while the power is on, install the removable-media device driver and set this option to *Disabled*.

Extended BIOS Translation for DOS Drives > 1Gbyte - This option allows you to enable or disable extended translation for SCSI hard disks with a capacity greater than 1 GByte. It is only valid if the host adapter BIOS is enabled. The default setting is *Enabled*. When this option is enabled, the following translation schemes are used:

- Disks < 1 GByte use a translation scheme of 64 heads, 32 sectors per track
- Disks > 1 GByte use a translation scheme of 255 heads, 63 sectors per track

Display <Hot><Key> Message During BIOS Initialization - This option allows you to enable or disable the BIOS prompt for the SCSI utility.

When this option is enabled, the following prompt appears on screen when the computer boots:

Press <Ctrl> <A> for SCSISelect(TM) Utility

Multiple Lun Support - When enabled, this option allows the BIOS to support Multiple logical units. Enable this option if any devices have multiple logical units.

BIOS Support for More Than 2 Drives - Under MS-DOS 5.0 and later versions, the AIC-78x0 BIOS supports up to eight standard (for example, IDE or EIDE) and SCSI hard drives without the need for drivers, as long as the BIOS Support for More Than 2 Drives is enabled.(The AIC-78x0 BIOS must also be enabled for this setting to be valid)

ADAPTEC® SCSISelect™ UTILITY

The operation of the AIC-78x0 BIOS on attached SCSI hard drives depends on the number of IDE and other standard hard drives running under DOS:

- **Operation with No IDE Hard Drives Installed:** The AIC-78x0 BIOS supports up to (8) SCSI drives. The BIOS scans all targets on the SCSI bus. If the BIOS cannot find the boot device specified in *SCSISelect*, the first drive or bootable CD-ROM the BIOS encounters on Int 13h becomes the boot drive.
- **Operation with One IDE Hard Drives Installed:** The AIC-78x0 BIOS supports up to (7) SCSI drives (a total of eight drives). The first standard drive or bootable CD-ROM encountered becomes the boot drive.
- **Operation with Two IDE Hard Drives Installed:** The AIC-78x0 BIOS support up to (6) SCSI drives (eight drives total). The first standard drive or bootable CD-ROM encountered becomes the boot drive.

BIOS Support for Bootable CD-ROM - This option appears only if the BIOS is configured to include it. Leave this option enabled to boot from a CD-ROM. If booting from a hard disk or other device, make sure no bootable CD-ROM is installed, or disable this option.

BIOS Support for Int 13h Extensions - This option appears only if the BIOS is configured to include bootable CD-ROM support. When this option is enabled, the adapter BIOS supports *EI Torito* Int 13h extensions, which are required for bootable CD-ROMs. You can disable this option if the boot device is not a CD-ROM; however, leaving it enabled causes no harm.

Support for Ultra SCSI Speed - This option appears only if the BIOS is configured to include Ultra SCSI support. Enable this option to use Ultra SCSI speeds with the AIC-78x0.

ADAPTEC® SCSISelect™ UTILITY

SCSI Disk Utilities

When you select SCSI Disk Utilities from the Options menu the SCSISelect utility scans the SCSI bus and lists all SCSI devices installed on the SCSI bus. You can easily determine from this screen which SCSI ID is assigned to each device on the SCSI bus.

```
Adaptec AIC-7880 Ultra/Ultra W ◀ SCSISelect(TM) ▶ Utility v1.22S2B
----- AIC-7880 Ultra/Ultra W at Bus:Device 00:10h -----
Select SCSI Disk and press <Enter>
SCSI ID # 0: Quantum P140S940-40-94xx
SCSI ID # 1: No Device
SCSI ID # 2: SyQuest SQ 5110
SCSI ID # 3: No Device
SCSI ID # 4: No Device
SCSI ID # 5: No Device
SCSI ID # 6: No Device
SCSI ID # 7: AIC-7880 Ultra/Ultra W
SCSI ID # 8: No Device
SCSI ID # 9: No Device
SCSI ID # 10: No Device
SCSI ID # 11: DEC DSP3160W
SCSI ID # 12: No Device
SCSI ID # 13: No Device
SCSI ID # 14: DEC DSP3160W
SCSI ID # 15: No Device
Arrow keys to move cursor, <Enter> to select option, <Esc> to exit (*=default)
```

Format Disk - The Format Disk utility performs a low-level format on disk devices. Your fixed disk media must be low-level formatted before you can use your operating system's partitioning and file preparation utilities, such as MS-DOS *fdisk* and *format*. Most SCSI disk devices are pre-low-level formatted and do not need to be formatted again. The Adapter Format Disk utility is compatible with the vast majority of SCSI disk drives. Run it on hard disk drives or removable-media drives that were previously used with a non-Adaptec host adapter.

Caution: A low-level format will destroy all data on the drive. Be sure to back up your data before performing this operation. You cannot abort a low-level format once it is started.

Verify Disk Media - Scans the selected device's media for defects. If the utility finds bad blocks, it prompts you to reassign them; if you select yes, these blocks will no longer be used. This Utility can be aborted by pressing [Esc].

ARO™-1130 PCI RAIDport™ Card

This mainboard provides a connector for an optional ARO™-1130 PCI RAIDport™ card located at the extension end of PCI slot 3. The ARO™-1130 RAID controller supports up to four arrays in any combination of RAID levels 0, 1, 0/1, or 5 to meet the performance and data redundancy requirements of your workstation or server system.

Supported RAID Levels:

RAID 0:	Data is <i>striped</i> across multiple disks without data redundancy. Used where disk performance is the top priority.
RAID 1:	Simultaneously reads and writes to dual hard disks, thereby <i>mirroring</i> the data. Used where data redundancy is the major concern.
RAID 0/1:	Combines the protection of mirroring with the high performance of data striping. The only RAID level that can tolerate multiple drive failures, RAID 0/1 is ideal for mission-critical applications.
RAID 5:	Uses <i>parity</i> information striped across multiple disks to provide data redundancy and increased performance. RAID 5 provides the best balance of fault-tolerance, speed, and storage cost for most applications.

A separate AIC-7810 RAID co-processor on the ARO-1130 card manages DRAM memory and offloads RAID 1 secondary writes and RAID 5 parity calculations from the host CPU, freeing it for other tasks. The DRAM memory module is isolated from the data path and memory is automatically bypassed when direct data transfer offers better performance.

The ARO-1130 RAIDport card is easy to install and configure. With its *ArrayConfig* software drives can be configured into arrays with a few simple menu-driven steps. The *ArrayConfig* software enhances fault-tolerance reliability by letting users set up an initial array configuration before the operating system is installed.

The Adaptec CI/O Array Management software takes the complexity out of array management. Arrays can be managed either locally from the host system or remotely from any PC over the network. In Windows® operating systems, an easy-to-use graphical user interface is provided.

Advanced Features:

- RAID co-processor
- Up to 3 mainboard SCSI channels supported
- Uses same cabling as mainboard SCSI
- Multiple operating system support
- Hot-swap drive support
- Hot-spare standby
- Dynamic sector repairing

ARO™-1130 PCI RAIDport™ Card

Technical Specifications:

Computer Bus:	32-bit PCI Local Bus and RAIDport socket connector
Interface Protocol:	Bus Master DMA
Host Burst Data Transfer Rate:	Up to 133MB/sec
Device Protocol:	SCSI Ultra, Fast, and Wide (8- and 16-bit) 20MHz
Advanced RAID Features:	RAID co-processor Hot spare (pool and dedicated) Hot swap of drives User-defined rebuild priority User-defined verify priority Bootable array support Hot-spare testing Scheduler for rebuild, verify, and hot-spare testing Array status monitoring and event notification User-selectable broadcast and monitoring Adjustable stripe width
Advanced Hardware Features:	DRAM memory of 1 or 4 Mbyte using 70ns parity protected SIMM modules (not included) Flash upgradeable firmware and BIOS
SCSI Channels:	1, 2, or 3 AIC-7880 mainboard SCSI chips connected to RAIDport
Device Support:	Up to 15 HDD/non-HDD SCSI devices per mainboard channel
Array Support:	Drives can be configured for RAID levels 0, 1, 0/1, and 5
Operating System Support:	Windows® 95* Windows NT NetWare OS/2 Warp* SCO OpenSever* UnixWare 2.x*
Remote management:	Windows 3.X Windows 95 Windows NT

*: Will be available soon.