



# Intel<sup>®</sup> CA810 Motherboard Technical Product Specification



*May 1999*

*Order Number 733082-001*

The Intel CA810 motherboard may contain design defects or errors known as errata that may cause the product to deviate from published specifications. Current characterized errata are documented in the CA810 Motherboard Specification Update.

# Revision History

---

| Revision | Revision History  | Date     |
|----------|---|----------|
| 001      | Final release of the CA810 Motherboard Technical Product Specification. | May 1999 |

This product specification applies only to standard CA810 motherboards with BIOS identifier 8C1A100A.86A. For BIOS Setup screen information for motherboards with BIOS identifier 8C1A100A.86R, refer to Section 4.1 on page 79. Other information in this specification applies to motherboards with either BIOS identifier 8C1A100A.86A or 8C1A100A.86R.

Changes to this specification will be published in the CA810 Motherboard Specification Update before being incorporated into a revision of this document.

Information in this document is provided in connection with Intel products. No license, express or implied, by estoppel or otherwise, to any intellectual property rights is granted by this document. Except as provided in Intel's Terms and Conditions of Sale for such products, Intel assumes no liability whatsoever, and Intel disclaims any express or implied warranty, relating to sale and/or use of Intel products including liability or warranties relating to fitness for a particular purpose, merchantability, or infringement of any patent, copyright or other intellectual property right. Intel products are not intended for use in medical, life saving, or life sustaining applications.

Intel may make changes to specifications and product descriptions at any time, without notice.

The CA810 motherboard may contain design defects or errors known as errata that may cause the product to deviate from published specifications. Current characterized errata are available on request.

Contact your local Intel sales office or your distributor to obtain the latest specifications before placing your product order.

Copies of documents which have an ordering number and are referenced in this document, or other Intel literature, may be obtained from:

Intel Corporation  
P.O. Box 5937  
Denver, CO 80217-9808

or call in North America 1-800-548-4725, Europe 44-0-1793-431-155, France 44-0-1793-421-777,  
Germany 44-0-1793-421-333, other Countries 708-296-9333.

† Third party brands and names are the property of their respective owners.

Copyright © Intel Corporation, 1999.

# Preface

---

This Technical Product Specification (TPS) specifies the board layout, components, connectors, power and environmental requirements, and BIOS for the Intel® CA810 motherboard. It describes the standard motherboard product and available manufacturing options.

## Intended Audience

The TPS is intended to provide detailed, technical information about the motherboard and its components to the vendors, system integrators, and other engineers and technicians who need this level of information. It is specifically *not* intended for general audiences.

## What This Document Contains

| Chapter | Description  |
|---------|--|
| 1       | A description of the hardware used on this board   |
| 2       | A map of the resources of the board  |
| 3       | The features supported by the BIOS Setup program   |
| 4       | The contents of the BIOS Setup program's menus and submenus                                |
| 5       | A description of the BIOS error messages, beep codes, and Power On Self Tests (POST) codes |
| 6       | A list of where to find information about specifications supported by the motherboard      |

## Typographical Conventions

This section contains information about the conventions used in this specification. Not all of these symbols and abbreviations appear in all specifications of this type.

## Notes, Cautions, and Warnings

### ⇒ NOTE

Notes call attention to important information.



### CAUTION

Cautions are included to help you avoid damaging hardware or losing data.



### WARNING

Warnings indicate conditions that, if not observed, can cause personal injury.

## Other Common Notation

|        |  |
|--------|--|
| ‡      | Indicates a feature that is implemented—at least in part—on a riser card.  |
| #      | Used after a signal name to identify an active-low signal (such as USBP0#).  |
| (NxnX) | When used in the description of a component, N indicates component type, xn are the relative coordinates of its location on the motherboard, and X is the instance of the particular part at that general location. For example, J5J1 is a connector, located at 5J. It is the first connector in the 5J area. |
| KB     | Kilobyte (1024 bytes).   |
| Kbit   | Kilobit (1024 bits).   |
| MB     | Megabyte (1,048,576 bytes).  |
| Mbit   | Megabit (1,048,576 bits).  |
| GB     | Gigabyte (1,073,741,824 bytes).  |
| xxh    | An address or data value ending with a lowercase h indicates a hexadecimal value.  |
| x.x V  | Volts. Voltages are DC unless otherwise specified.   |
| †      | This symbol is used to indicate third-party brands and names that are the property of their respective owners.   |

# Contents

---

## 1 Motherboard Description

|        |  |    |
|--------|--|----|
| 1.1    | Overview .....   | 12 |
| 1.2    | Motherboard Layout .....                                   | 14 |
| 1.3    | Processor .....  | 16 |
| 1.4    | System Memory.....   | 16 |
| 1.5    | Chipset.....   | 17 |
| 1.6    | USB.....   | 18 |
| 1.7    | IDE Support.....   | 18 |
| 1.8    | Real-Time Clock, CMOS SRAM, and Battery .....              | 19 |
| 1.9    | I/O Controller .....                                       | 19 |
| 1.9.1  | Serial Port .....  | 20 |
| 1.9.2  | Infrared Support .....                                     | 20 |
| 1.9.3  | Parallel Port.....   | 20 |
| 1.9.4  | Diskette Drive Controller.....                             | 20 |
| 1.9.5  | Keyboard and Mouse Interface .....                         | 21 |
| 1.10   | Graphics Subsystem .....                                   | 21 |
| 1.10.1 | Intel® 82810 GMCH.....                                     | 21 |
| 1.10.2 | Intel 82810 GMCH DC-100 (Optional).....                    | 22 |
| 1.11   | Audio Subsystem.....                                       | 23 |
| 1.11.1 | Creative Sound Blaster AudioPCI 64V Audio Controller ..... | 23 |
| 1.11.2 | Crystal Semiconductor CS4297 Stereo Audio Codec .....      | 23 |
| 1.11.3 | Audio Connectors.....                                      | 23 |
| 1.12   | Hardware Management Features (Optional).....               | 24 |
| 1.12.1 | Hardware Monitor Component .....                           | 25 |
| 1.12.2 | Alert on LAN Component.....                                | 25 |
| 1.12.3 | Chassis Intrusion Detect Connector .....                   | 25 |
| 1.13   | SCSI Hard Drive Activity LED Connector (Optional) .....    | 25 |
| 1.14   | LAN Subsystem (Optional) .....                             | 26 |
| 1.14.1 | Intel® 82559 LAN Controller .....                          | 26 |
| 1.14.2 | LAN Subsystem Software.....                                | 26 |
| 1.14.3 | RJ-45 LAN Connector LEDs.....                              | 27 |
| 1.15   | Power Management Features.....                             | 27 |
| 1.15.1 | Software Support .....                                     | 27 |
| 1.15.2 | Hardware Support .....                                     | 30 |
| 1.16   | Fan Connectors .....                                       | 33 |
| 1.17   | Motherboard Connectors .....                               | 34 |
| 1.17.1 | Back Panel Connectors .....                                | 35 |
| 1.17.2 | Midboard Connectors .....                                  | 39 |
| 1.17.3 | Front Panel Connectors .....                               | 50 |
| 1.18   | Jumper Blocks .....  | 53 |
| 1.18.1 | BIOS Setup Configuration Jumper Block.....                 | 54 |
| 1.18.2 | USB Port 0 Configuration Jumper Block (Optional) .....     | 54 |

|          |  |    |
|----------|--|----|
| 1.19     | Mechanical Considerations.....                         | 55 |
| 1.19.1   | Form Factor.....                                       | 55 |
| 1.19.2   | I/O Shield .....                                       | 56 |
| 1.20     | Electrical Considerations .....                        | 57 |
| 1.20.1   | Power Consumption .....                                | 57 |
| 1.20.2   | Add-in Board Considerations.....                       | 58 |
| 1.20.3   | Fan Power Requirements.....                            | 58 |
| 1.20.4   | Power Supply Considerations.....                       | 58 |
| 1.21     | Thermal Considerations.....                            | 59 |
| 1.22     | Reliability .....                                      | 60 |
| 1.23     | Environmental Specifications.....                      | 61 |
| 1.24     | Regulatory Compliance .....                            | 62 |
| 1.24.1   | Safety Regulations .....                               | 62 |
| 1.24.2   | Safety Regulations .....                               | 62 |
| 1.24.3   | Certification Markings.....                            | 63 |
| <b>2</b> | <b>Motherboard Resources</b>                           |    |
| 2.1      | Memory Map .....                                       | 65 |
| 2.2      | DMA Channels .....                                     | 65 |
| 2.3      | I/O Map .....  | 66 |
| 2.4      | PCI Configuration Space Map .....                      | 68 |
| 2.5      | Interrupts .....                                       | 68 |
| 2.6      | PCI Interrupt Routing Map.....                         | 69 |
| <b>3</b> | <b>Overview of BIOS Features</b>                       |    |
| 3.1      | Introduction.....                                      | 71 |
| 3.2      | BIOS Flash Memory Organization .....                   | 72 |
| 3.3      | Resource Configuration .....                           | 72 |
| 3.3.1    | PCI Autoconfiguration .....                            | 72 |
| 3.3.2    | PCI IDE Support.....                                   | 73 |
| 3.4      | System Management BIOS (SMBIOS) .....                  | 73 |
| 3.5      | BIOS Upgrades .....                                    | 74 |
| 3.5.1    | Language Support.....                                  | 74 |
| 3.5.2    | Custom Splash Screen.....                              | 74 |
| 3.6      | Recovering BIOS Data .....                             | 74 |
| 3.7      | Boot Options.....                                      | 75 |
| 3.7.1    | CD-ROM and Network Boot .....                          | 75 |
| 3.7.2    | Booting Without Attached Devices .....                 | 75 |
| 3.7.3    | Default Settings After Battery and Power Failure ..... | 75 |
| 3.8      | USB Legacy Support .....                               | 76 |
| 3.9      | BIOS Security Features .....                           | 77 |

## 4 BIOS Setup Program

|       |  |    |
|-------|--|----|
| 4.1   | Introduction.....                        | 79 |
| 4.2   | Maintenance Menu .....                   | 80 |
| 4.3   | Main Menu.....                           | 80 |
| 4.4   | Advanced Menu.....                       | 81 |
| 4.4.1 | Boot Setting Configuration Submenu ..... | 81 |
| 4.4.2 | Peripheral Configuration Submenu.....    | 82 |
| 4.4.3 | IDE Configuration .....                  | 83 |
| 4.4.4 | IDE Configuration Submenus .....         | 84 |
| 4.4.5 | Diskette Configuration Submenu .....     | 85 |
| 4.4.6 | Event Log Configuration.....             | 85 |
| 4.5   | Security Menu.....                       | 86 |
| 4.6   | Power Menu .....                         | 86 |
| 4.7   | Boot Menu .....                          | 87 |
| 4.8   | Exit Menu .....                          | 88 |

## 5 Error Messages and Beep Codes

|     |                                       |    |
|-----|---------------------------------------|----|
| 5.1 | BIOS Error Messages.....              | 89 |
| 5.2 | Port 80h POST Codes.....              | 91 |
| 5.3 | Bus Initialization Checkpoints .....  | 95 |
| 5.4 | Speaker .....                         | 96 |
| 5.5 | BIOS Beep Codes .....                 | 96 |
| 5.6 | Enhanced Diagnostics (Optional) ..... | 97 |

## 6 Specifications and Customer Support

|     |                      |    |
|-----|----------------------|----|
| 6.1 | Online Support.....  | 99 |
| 6.2 | Specifications ..... | 99 |

## Figures

|     |   |    |
|-----|---|----|
| 1.  | microATX Motherboard Components.....                                    | 14 |
| 2.  | Motherboard Block Diagram .....   | 15 |
| 3.  | Intel 810 Chipset Block Diagram.....                                    | 17 |
| 4.  | Using the Wake on LAN Technology Connector.....                         | 31 |
| 5.  | Location of Standby Power Indicator LED .....                           | 32 |
| 6.  | Connector Groups .....  | 34 |
| 7.  | Back Panel Connectors and Indicators .....                              | 35 |
| 8.  | Midboard Audio Connectors .....   | 40 |
| 9.  | Peripheral Interface Connectors .....                                   | 42 |
| 10. | Hardware Management and Power Connectors .....                          | 45 |
| 11. | PCI Bus Add-In Board Connectors .....                                   | 48 |
| 12. | Front Panel Connectors.....   | 50 |
| 13. | Location of the Jumper Blocks.....                                      | 53 |
| 14. | Motherboard Dimensions.....   | 55 |
| 15. | Back Panel I/O Shield Dimensions (microATX Chassis - Independent) ..... | 56 |
| 16. | Thermally-sensitive Components.....                                     | 59 |
| 17. | Memory Map of the Flash Memory Device .....                             | 72 |
| 18. | Enhanced Diagnostics LEDs .....   | 97 |

## Tables

|     |   |    |
|-----|---|----|
| 1.  | Processors Supported by the Motherboard .....                           | 16 |
| 2.  | Intel 82810 GMCH Refresh Rates .....                                    | 22 |
| 3.  | RJ-45 LAN Connector LEDs .....  | 27 |
| 4.  | Effects of Pressing the Power Switch .....                              | 28 |
| 5.  | Power States and Targeted System Power .....                            | 29 |
| 6.  | Wake Up Devices and Events .....  | 30 |
| 7.  | PS/2 Keyboard/Mouse Connectors.....                                     | 36 |
| 8.  | RJ-45 LAN Connector (optional).....                                     | 36 |
| 9.  | USB Connectors.....   | 36 |
| 10. | Serial Port Connector .....   | 36 |
| 11. | Parallel Port Connector.....  | 37 |
| 12. | VGA Connector .....   | 37 |
| 13. | MIDI/Game Port Connector .....  | 38 |
| 14. | Audio Line-In Connector .....   | 38 |
| 15. | Audio Line-Out Connector .....  | 38 |
| 16. | Audio Mic-In Connector .....  | 38 |
| 17. | ATAPI CD-ROM Connector (J2C2) .....                                     | 41 |
| 18. | Optional Video Source Line In Connector (J2C1) .....                    | 41 |
| 19. | Optional Legacy CD-ROM Connector (J1C1) .....                           | 41 |
| 20. | Optional Auxiliary Line In Connector (J2D2) .....                       | 41 |
| 21. | Optional Telephony Connector (J2D3).....                                | 41 |
| 22. | Serial Port B Connector (J2D1) .....                                    | 43 |
| 23. | Optional USB Front Panel Connector (J8C1).....                          | 43 |
| 24. | Optional SCSI Hard Drive Activity LED Connector (J8A2) (optional) ..... | 43 |
| 25. | Diskette Drive Connector (J9E1) .....                                   | 43 |
| 26. | PCI IDE Connectors (J9D1, J9F1).....                                    | 44 |
| 27. | Fan 3 (Processor) Connector (J3J1).....                                 | 46 |
| 28. | Optional Fan 2 Connector (J7G1).....                                    | 46 |
| 29. | Power Connector (J8D1) .....  | 46 |
| 30. | Fan 1 (Chassis Fan) Connector (J9C1) .....                              | 46 |
| 31. | Optional Wake on LAN Technology Connector (J8A3) .....                  | 47 |
| 32. | Optional Chassis Intrusion Connector (J7B1) .....                       | 47 |
| 33. | PCI Bus Connectors .....  | 49 |
| 34. | Front Panel Connector (J10B1) .....                                     | 51 |
| 35. | Power LED (Single-colored) .....  | 51 |
| 36. | Power LED (Dual-colored).....   | 51 |
| 37. | Power LED Front Panel Connector (J9A2) .....                            | 52 |
| 38. | BIOS Setup Configuration Jumper Settings.....                           | 54 |
| 39. | USB Port 0 Configuration Jumper Settings.....                           | 54 |
| 40. | Power Usage .....   | 57 |
| 41. | Standby Current Usage .....   | 58 |
| 42. | Fan 3 (Processor Fan) DC Power Requirements.....                        | 58 |
| 43. | Thermal Considerations for Components .....                             | 60 |
| 44. | Environmental Specifications.....                                       | 61 |
| 45. | Safety Regulations .....  | 62 |
| 46. | EMC Regulations.....  | 62 |

|     |  |    |
|-----|--|----|
| 47. | System Memory Map.....                             | 65 |
| 48. | DMA Channels .....                                 | 65 |
| 49. | I/O Map .....                                      | 66 |
| 50. | PCI Configuration Space Map .....                  | 68 |
| 51. | Interrupts .....                                   | 68 |
| 52. | PCI Interrupt Routing Map .....                    | 69 |
| 53. | Supervisor and User Password Functions .....       | 77 |
| 54. | Setup Menu Bar.....                                | 79 |
| 55. | Setup Function Keys.....                           | 80 |
| 56. | Maintenance Menu .....                             | 80 |
| 57. | Main Menu.....                                     | 80 |
| 58. | Advanced Menu.....                                 | 81 |
| 60. | Peripheral Configuration Submenu .....             | 82 |
| 61. | IDE Device Configuration .....                     | 83 |
| 62. | IDE Configuration Submenus .....                   | 84 |
| 63. | Diskette Configuration Submenu .....               | 85 |
| 64. | Event Log Configuration Submenu .....              | 85 |
| 65. | Security Menu.....                                 | 86 |
| 66. | Power Menu .....                                   | 86 |
| 67. | Boot Menu .....                                    | 87 |
| 68. | Exit Menu .....                                    | 88 |
| 69. | BIOS Error Messages.....                           | 89 |
| 70. | Uncompressed INIT Code Checkpoints.....            | 91 |
| 71. | Boot Block Recovery Code Checkpoints .....         | 91 |
| 72. | Runtime Code Uncompressed in F000 Shadow RAM ..... | 92 |
| 73. | Beep Codes.....                                    | 96 |
| 74. | Diagnostic LED Codes.....                          | 98 |
| 75. | Compliance with Specifications .....               | 99 |



# 1 Motherboard Description

---

## What This Chapter Contains

|      |   |    |
|------|---|----|
| 1.1  | Overview .....  | 12 |
| 1.2  | Motherboard Layout .....                                | 14 |
| 1.3  | Processor .....   | 16 |
| 1.4  | System Memory.....                                      | 16 |
| 1.5  | Chipset .....   | 17 |
| 1.6  | USB.....  | 18 |
| 1.7  | IDE Support.....  | 18 |
| 1.8  | Real-Time Clock, CMOS SRAM, and Battery .....           | 19 |
| 1.9  | I/O Controller .....                                    | 19 |
| 1.10 | Graphics Subsystem .....                                | 21 |
| 1.11 | Audio Subsystem.....                                    | 23 |
| 1.12 | Hardware Management Features (Optional).....            | 24 |
| 1.13 | SCSI Hard Drive Activity LED Connector (Optional) ..... | 25 |
| 1.14 | LAN Subsystem (Optional) .....                          | 26 |
| 1.15 | Power Management Features.....                          | 27 |
| 1.16 | Fan Connectors .....                                    | 33 |
| 1.17 | Motherboard Connectors .....                            | 34 |
| 1.18 | Jumper Blocks .....                                     | 53 |
| 1.19 | Mechanical Considerations.....                          | 55 |
| 1.20 | Electrical Considerations .....                         | 57 |
| 1.21 | Thermal Considerations.....                             | 59 |
| 1.22 | Reliability .....                                       | 60 |
| 1.23 | Environmental Specifications.....                       | 61 |
| 1.24 | Regulatory Compliance .....                             | 62 |

## 1.1 Overview

The CA810 motherboard's features are summarized below.

|                               |   |
|-------------------------------|---|
| <b>Form Factor</b>            | microATX (9.6 inches by 9.6 inches)   |
| <b>Processor</b>              | Support for Intel® Celeron™ processor, in a 370-pin PPGA socket, with 66 MHz host bus speed   |
| <b>Chipset</b>                | The Intel® 810 chipset consisting of: <ul style="list-style-type: none"> <li>• Intel® 82810 Graphics/Memory Controller Hub (GMCH)</li> <li>• Intel® 82801AA I/O Controller Hub (ICH)</li> <li>• Intel® 82802AB Firmware Hub (FWH)</li> </ul>  |
| <b>Memory</b>                 | <ul style="list-style-type: none"> <li>• Two 168-pin dual inline memory module (DIMM) sockets</li> <li>• Support for up to 512 MB of 100-MHz, non-ECC, unbuffered synchronous DRAM (SDRAM) <ul style="list-style-type: none"> <li>— 32 MB to 256 MB using 16 MB/64 Mbit technology</li> <li>— 512 MB maximum using 128 Mbit technology</li> </ul> </li> <li>• Support for serial presence detect (SPD) and non-SPD DIMMs</li> </ul> |
| <b>I/O Control</b>            | SMSC LPC47B272 low pin count (LPC) interface super I/O controller   |
| <b>Peripheral Interfaces</b>  | <ul style="list-style-type: none"> <li>• Two serial ports</li> <li>• Two USB ports</li> <li>• One parallel port</li> <li>• PS/2 keyboard</li> <li>• PS/2 mouse</li> </ul>   |
| <b>Audio Subsystem</b>        | <ul style="list-style-type: none"> <li>• Creative Sound Blaster† AudioPCI 64V audio controller</li> <li>• AC '97 Crystal Semiconductor CS4297 stereo audio codec</li> </ul>   |
| <b>Graphics Subsystem</b>     | <ul style="list-style-type: none"> <li>• Intel 82810 Graphics/Memory Controller Hub (integrated in the chipset)</li> </ul>  |
| <b>Expansion Capabilities</b> | <ul style="list-style-type: none"> <li>• Four PCI slots</li> </ul>  |
| <b>BIOS</b>                   | <ul style="list-style-type: none"> <li>• Intel/AMI BIOS</li> <li>• Intel 82802AB Firmware Hub (FWH) 4 Mbit flash memory</li> <li>• Support for SMBIOS, Advanced Configuration and Power Management Interface (ACPI), Advanced Power Management (APM), and Plug and Play (see Section 6.2 for specification compliance levels)</li> </ul>  |
| <b>Other Features</b>         | <ul style="list-style-type: none"> <li>• Speaker</li> </ul>   |

Not all of the following manufacturing options are available in all marketing channels. Please contact your Intel representative to determine what manufacturing options are available to you.

### Manufacturing Options

|                                   |   |
|-----------------------------------|---|
| <b>Audio</b>                      | Sony/Phillips digital interface format (S/P-DIF) connector  |
| <b>Chassis Intrusion</b>          | Support for chassis intrusion detection   |
| <b>Fan Connector</b>              | The fan 2 connector is optional   |
| <b>Hardware Monitor Subsystem</b> | <ul style="list-style-type: none"> <li>• Wired for Management (WfM) compliant (see section 6.2 for compliance level)</li> <li>• Voltage sensor to detect out of range values</li> </ul> |
| <b>Graphics Subsystem</b>         | Intel 82810 DC-100 Graphics/Memory Controller Hub with support for 1 M x 16 (4 MB) display cache  |
| <b>Enhanced Diagnostics</b>       | Embedded diagnostics and LEDs that supplement beep codes during POST  |
| <b>LAN Controller</b>             | <ul style="list-style-type: none"> <li>• Intel® 82559 PCI LAN controller with RJ-45 LAN connector</li> <li>• Wake on LAN<sup>†</sup> technology</li> </ul>                              |

## 1.2 Motherboard Layout

Figure 1 shows the major components of the CA810 motherboard.

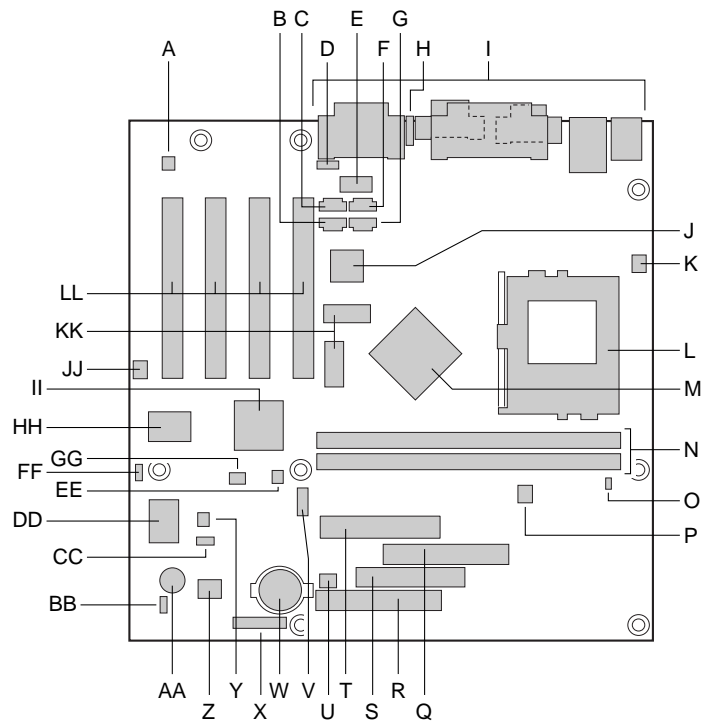

OM07766

|   |   |    |  |
|---|---|----|--|
| A | Crystal Semiconductor CS4297 audio codec          | T  | Power supply connector                                 |
| B | ATAPI-style CD-ROM connector                      | U  | Fan 1 (chassis) connector                              |
| C | Video source line in connector (optional)         | V  | USB Port 0 front panel connector (optional)            |
| D | Legacy CD-ROM connector (optional)                | W  | Battery  |
| E | Serial port B header                              | X  | Front panel connector                                  |
| F | Auxiliary line in connector (optional)            | Y  | SCSI HD activity LED connector (optional)              |
| G | Telephony connector (optional)                    | Z  | Intel 82802AB Firmware Hub (FWH)                       |
| H | Enhanced diagnostics LEDs (optional)              | AA | Speaker  |
| I | Back panel connectors                             | BB | Power LED  |
| J | Intel 82559 LAN controller (optional)             | CC | Wake on LAN technology connector (optional)            |
| K | Fan 3 (processor) connector                       | DD | SMSC LPC47B272 super I/O controller                    |
| L | 370-pin PPGA processor socket                     | EE | Chassis intrusion connector (optional)                 |
| M | Intel 82810 Graphics/Memory Controller Hub (GMCH) | FF | Configuration jumper block                             |
| N | DIMM sockets                                      | GG | USB Port 1 front panel configuration jumper (optional) |
| O | Hardware monitor (optional)                       | HH | Creative Sound Blaster AudioPCI 64V audio controller   |
| P | Fan 2 connector (optional)                        | II | Intel 82801AA I/O Controller Hub (ICH)                 |
| Q | Secondary IDE connector                           | JJ | S/P-DIF connector (optional)                           |
| R | Primary IDE connector                             | KK | Video memory (optional)                                |
| S | Diskette drive connector                          | LL | PCI slots  |

**Figure 1. microATX Motherboard Components**

Figure 2 is a block diagram showing the relationship among the major components.

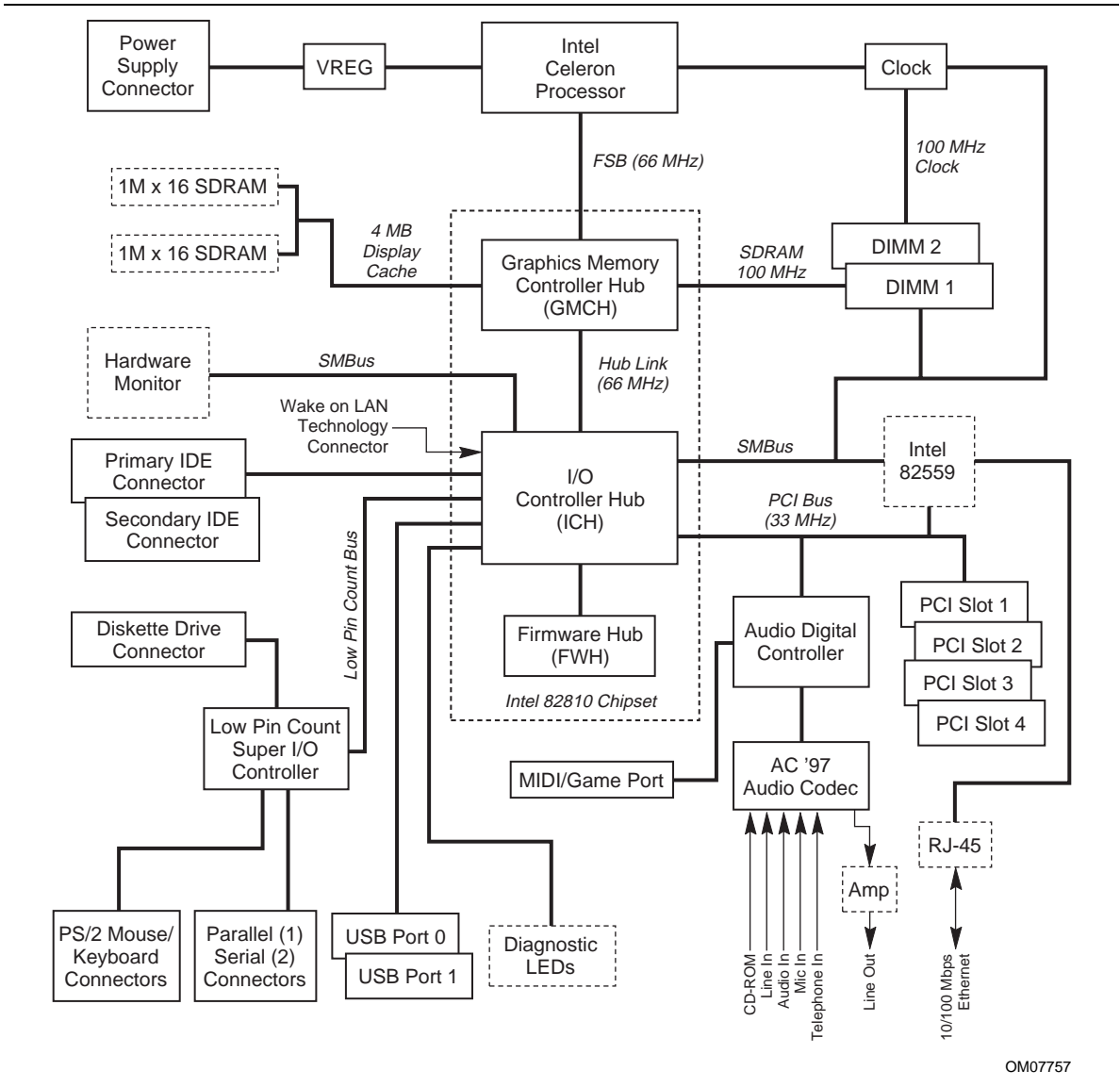

OM07757

Figure 2. Motherboard Block Diagram

## 1.3 Processor

The motherboard supports a single Celeron processor. The processor's VID pins automatically program the voltage regulator on the motherboard to the required processor voltage. The host bus speed of 66 MHz is automatically selected. The processor connects to the motherboard through the 370-pin PPGA socket.

The motherboard supports the processors listed in Table 1.

**Table 1. Processors Supported by the Motherboard**

| Processor Speed | Host Bus Frequency | Cache Size |
|-----------------|--------------------|------------|
| 333 MHz         | 66 MHz             | 128 KB     |
| 366 MHz         | 66 MHz             | 128 KB     |
| 400 MHz         | 66 MHz             | 128 KB     |
| 433 MHz         | 66 MHz             | 128 KB     |
| 466 MHz         | 66 MHz             | 128 KB     |

All supported onboard memory can be cached.

For the latest information on processor support for the CA810 motherboard, refer to the Intel boxed motherboard web site at:

<http://support.intel.com/support/motherboards/desktop/>

## 1.4 System Memory

The motherboard has two DIMM sockets. SDRAM can be installed in one or both sockets. Minimum memory size is 32 MB; maximum memory size is 512 MB. The BIOS automatically detects memory type, size, and speed. Due to the video requirements of the CA810 motherboard, minimum memory for the Windows NT<sup>†</sup> 4.0 operating system is 64 MB.

### ⇒ NOTE

*Processors with 66 MHz host bus can be paired with either 66 MHz or 100 MHz SDRAM.*

The motherboard supports memory with the following features:

- 168-pin DIMMs with gold-plated contacts
- 100 MHz unbuffered SDRAM
- Non-ECC (64-bit) memory
- 100 MHz memory may be either Serial Presence Detect (SPD) or non-SPD memory
- 3.3 V memory only



### CAUTION

*Because the main system memory is also used as video memory, the CA810 motherboards require 100 MHz SDRAM DIMMs even though the processor front side bus is 66 MHz. It is **highly** recommended that SPD DIMMs be used, since this allows the chipset to accurately configure memory settings for optimum performance. If non-SPD memory is installed, the BIOS will attempt to correctly configure the memory settings, but performance and reliability may be impacted.*

The motherboard supports single- or double-sided DIMMs in the following sizes:

| DIMM Size | Non-ECC Configuration |
|-----------|-----------------------|
| 16 MB     | 2 Mbit x 64           |
| 32 MB     | 4 Mbit x 64           |
| 64 MB     | 8 Mbit x 64           |
| 128 MB    | 16 Mbit x 64          |
| 256 MB    | 32 Mbit x 64          |

## ⇒ NOTE

All memory components and DIMMs used with the CA810 motherboard must comply with the PC SDRAM Unbuffered DIMM Specification. You can access this document through the Internet at:

<http://www.intel.com/design/chipsets/memory/index.htm>

See Section 6.2 for information about this SDRAM DIMM specification.

## 1.5 Chipset

The Intel 810 chipset consists of the following devices:

- Graphics Memory Controller Hub (GMCH)
- I/O Controller Hub (ICH)
- Firmware Hub (FWH)

The chipset provides the host, memory, graphics, and I/O interfaces shown in Figure 3.

For information about the Intel 810 chipset, refer to the Intel web site at:

<http://developer.intel.com>

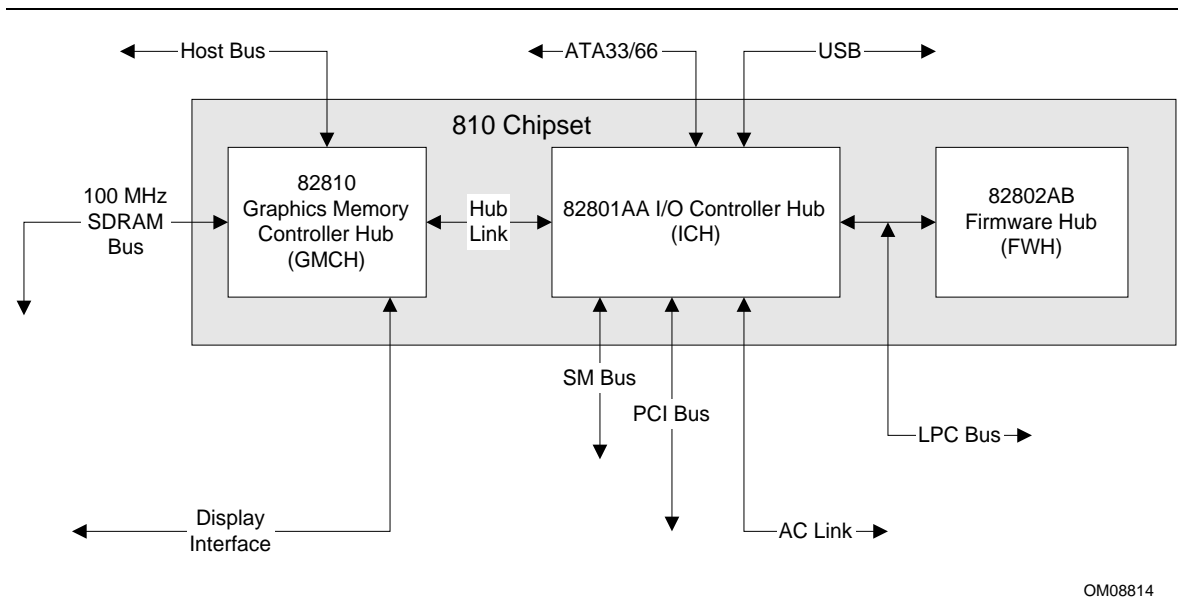

OM08814

Figure 3. Intel 810 Chipset Block Diagram

## 1.6 USB

The motherboard has two USB ports; one USB peripheral can be connected to each port. For more than two USB devices, an external hub can be connected to either port. The two USB ports are implemented with stacked back panel connectors. The motherboard fully supports UHCI and uses UHCI-compatible software drivers. See Section 6.2 for information about the USB and UHCI specifications.

USB features include:

- Self-identifying peripherals that can be plugged in while the computer is running
- Automatic mapping of function to driver and configuration
- Support for isochronous and asynchronous transfer types over the same set of wires
- Support for up to 127 physical devices
- Guaranteed bandwidth and low latencies appropriate for telephony, audio, and other applications
- Error-handling and fault-recovery mechanisms built into the protocol

### ⇒ NOTE

*Computer systems that have an unshielded cable attached to a USB port may not meet FCC Class B requirements, even if no device or a low-speed USB device is attached to the cable. Use shielded cable that meets the requirements for full-speed devices.*

## 1.7 IDE Support

The motherboard has two independent bus-mastering IDE interfaces. These interfaces support:

- ATAPI devices (such as CD-ROM drives)
- Ultra ATA/33 and Ultra ATA/66 devices

The BIOS supports logical block addressing (LBA) and extended cylinder head sector (ECHS) translation modes. The drive reports the transfer rate and translation mode to the BIOS.

The motherboard supports laser servo (LS-120) diskette technology through its IDE interfaces. The LS-120 drive can be configured as a boot device by setting the BIOS Setup program's Boot Device Menu (see Section 4.7) to one of the following:

- ARMD-FDD (ATAPI Removable Media Device - Floppy Disk Drive)
- ARMD-HDD (ATAPI Removable Media Device - Hard Disk Drive)

## 1.8 Real-Time Clock, CMOS SRAM, and Battery

The real-time clock is compatible with DS1287 and MC146818 components. The clock provides a time-of-day clock and a multicentury calendar with alarm features and century rollover. The real-time clock supports 256 bytes of battery-backed CMOS SRAM in two banks that are reserved for BIOS use.

The time, date, and CMOS values can be specified in the Setup program. The CMOS values can be returned to their defaults by using the Setup program.

### ⇒ NOTE

*The recommended method of accessing the date in systems with Intel® motherboards is from the Real-Time Clock (RTC) via the BIOS. The BIOS on Intel motherboards contains a century checking and maintenance feature that checks the least two significant digits of the year stored in the RTC during each BIOS request (INT 1Ah). During this check, the BIOS reads the date and, if less than 80 (i.e., 1980 is the first year supported by the PC), updates the century byte to 20. This feature enables operating systems and applications using the BIOS date/time services to reliably manipulate the year as a four-digit value.*

*For more information on proper date access in systems with Intel motherboards, please see*

<http://support.intel.com/support/year2000/motherboard.htm>

A coin-cell battery powers the real-time clock and CMOS memory. When the computer is not plugged into a wall socket, the battery has an estimated life of three years. When the computer is plugged in, the 3.3 V standby current extends the life of the battery. The clock is accurate to  $\pm 13$  minutes/year at 25 °C with 3.3 V applied.

## 1.9 I/O Controller

The SMSC LPC47B272 super I/O controller provides the following features:

- Low pin count (LPC) interface
- Two serial ports
- Infrared port (IrDA† 1.1 compliant)
- One parallel port with Extended Capabilities Port (ECP) and Enhanced Parallel Port (EPP) support
- PS/2-style mouse and keyboard interfaces
- Interface for one 1.2 MB, 1.44 MB, or 2.88 MB diskette drive
- Intelligent power management, including a programmable wake up event interface
- Fan control:
  - Two pulse width modulation (PWM) fan speed control outputs
  - Two fan tachometer inputs

The BIOS Setup program provides configuration options for the I/O controller.

### 1.9.1 Serial Port

The motherboard has one 9-pin D-Sub serial port connector located on the back panel and an optional connector on the board for a second serial port. The serial ports' NS16C550-compatible UARTs support data transfers at speeds up to 115.2 Kbits/sec with BIOS support. The serial ports can be assigned as COM1 (3F8h), COM2 (2F8h), COM3 (3E8h), or COM4 (2E8h).

### 1.9.2 Infrared Support

On the front panel connector, there are four pins that support Hewlett Packard HSDL-1000 compatible infrared (IR) transmitters and receivers. In the BIOS Setup program, Serial Port B can be directed to a connected IR device. (In this case, the Serial Port B connector on the back panel cannot be used.) The IR connection can be used to transfer files to or from portable devices like laptops, PDAs, and printers. The Infrared Data Association (IrDA) specification supports data transfers of 115 Kbits/sec at a distance of 1 meter. For information about the IrDA specification, see Section 6.2.

### 1.9.3 Parallel Port

The connector for the multimode bidirectional parallel port is a 25-pin D-Sub connector located on the back panel of the motherboard. In the Setup program, there are four options for parallel port operation:

- Output Only
- Bidirectional (PS/2 compatible)
- EPP
- ECP

### 1.9.4 Diskette Drive Controller

The I/O controller supports a single diskette drive that is compatible with the 82077 diskette drive controller and supports both PC-AT<sup>†</sup> or PS/2 modes. For information about the diskette drive capacities and sizes, see Table 63 on page 85.

#### ⇒ NOTE

*The I/O controller supports 1.2 MB, 3.5-inch diskette drives, but a special driver is required for this type of drive.*

## 1.9.5 Keyboard and Mouse Interface

PS/2 keyboard and mouse connectors are located on the back panel of the motherboard. The +5 V lines to these connectors are protected with a PolySwitch<sup>†</sup> circuit that, like a self-healing fuse, reestablishes the connection after an overcurrent condition is removed.

### ⇒ NOTE

*The mouse and keyboard can be plugged into either PS/2 connector. Power to the computer should be turned off before a keyboard or mouse is connected or disconnected.*

The keyboard controller contains code that provides the traditional keyboard and mouse control functions and also supports Power On/Reset password protection. A Power On/Reset password can be specified in the BIOS Setup program.

## 1.10 Graphics Subsystem

The graphics subsystem features the Intel 82810 Graphics/Memory Controller Hub (GMCH).

Visit Intel's World Wide Web (see Section 6.2) site for information about graphics drivers.

### 1.10.1 Intel<sup>®</sup> 82810 GMCH

The Intel 82810 GMCH features the following:

- Integrated graphics controller
  - 3-D Hyper Pipelined architecture
  - Full 2-D hardware acceleration
  - Motion video acceleration
- 3-D graphics visual and texturing enhancements
- Display
  - Integrated 24-bit 230 MHz RAMDAC
  - Display Data Channel Standard, Version 3.0, Level 2B protocols compliant (see Section 6.2 for specification information)
- Video
  - Hardware motion compensation for software MPEG2 decode
  - Software DVD at 30 fps
- Integrated graphics memory controller

Table 2 lists the refresh rates supported by the CA810 motherboard.

**Table 2. Intel 82810 GMCH Refresh Rates**

| Resolution | Color | 60 (Hz) | 70 (Hz) | 72 (Hz) | 75 (Hz) | 85 (Hz) |
|------------|-------|---------|---------|---------|---------|---------|
| 640x200    | 16    |         | x       |         |         |         |
| 640x350    | 16    |         | x       |         |         |         |
| 640x400    | 256   | x       | x       |         | x       | x       |
|            | 64 K  | x       | x       |         | x       | x       |
|            | 16 M  |         | x       |         |         |         |
| 640x480    | 16    | x       |         | x       | x       | x       |
|            | 256   | x       | x       | x       | x       | x       |
|            | 32 K  | x       |         |         | x       | x       |
|            | 64 K  | x       | x       | x       | x       | x       |
|            | 16 M  | x       | x       | x       | x       | x       |
| 800x600    | 256   | x       | x       | x       | x       | x       |
|            | 32 K  | x       |         |         | x       | x       |
|            | 64 K  | x       | x       | x       | x       | x       |
|            | 16 M  | x       | x       | x       | x       | x       |
| 1024x768   | 256   | x       | x       |         | x       | x       |
|            | 32 K  | x       |         |         | x       | x       |
|            | 64 K  | x       | x       | x       | x       | x       |
|            | 16 M  | x       | x       | x       | x       | x       |
| 1056x800   | 16    |         | x       |         |         |         |
| 1280x1024  | 256   | x       | x       | x       | x       | x       |
|            | 32 K  | x       |         |         | x       |         |
|            | 64 K  | x       | x       | x       | x       | x       |
|            | 16 M  | x       | x       | x       | x       | x       |

#### ⇒ NOTE

*Some of the system memory is reserved for video.*

### 1.10.2 Intel 82810 GMCH DC-100 (Optional)

In addition to all the features of the Intel 82810 GMCH, the optional Intel 82810 GMCH DC-100 includes 4 MB of display cache.

See Intel's World Wide Web site for information about graphics drivers:

*<http://support.intel.com/support/motherboards/desktop/>*

## 1.11 Audio Subsystem

The Audio Codec '97 (AC '97) compatible audio subsystem includes these features:

- Split digital/analog architecture for improved signal-to-noise ratio ( $\geq 85$  dB) measured at line out, from any analog input, including line in, CD-ROM, and auxiliary line in
- 3-D stereo enhancement
- Power management support for APM 1.2 and ACPI 1.0

The audio subsystem consists of these devices:

- Sound Blaster AudioPCI 64V audio controller
- Crystal Semiconductor CS4297 stereo audio codec
- Audio connectors

### 1.11.1 Creative Sound Blaster AudioPCI 64V Audio Controller

The Creative Sound Blaster AudioPCI 64V audio controller features:

- Interfaces to PCI bus as a Plug and Play device
- 100% DOS legacy compatible
- Access to main memory (through the PCI bus) for wavetable synthesis support – does not require a separate wavetable ROM device
- Conforms to the PC 98 and PC 99 design guides
- Optional Sony/Phillips digital interface format (S/P-DIF)

### 1.11.2 Crystal Semiconductor CS4297 Stereo Audio Codec

The Crystal Semiconductor CS4297 stereo audio codec features:

- High performance 18-bit stereo full-duplex audio codec with up to 48 kHz sampling rate
- Connects to the Sound Blaster AudioPCI 64V using a five-wire digital interface

### 1.11.3 Audio Connectors

The audio connectors include the following:

- Optional CD-ROM (legacy-style)
- ATAPI-style connectors
  - CD-ROM
  - Auxiliary line in (optional)
  - Telephony (optional)
  - Video source line in (optional)
- Back panel connectors
  - Line out
  - Line in
  - Mic in
  - MIDI/Game Port

⇒ **NOTE**

*The line out connector, located on the back panel, is designed to power either headphones or amplified speakers only. Poor audio quality may occur if passive (non-amplified) speakers are connected to this output.*

**1.11.3.1 CD-ROM (Legacy-style 2 mm) Connector (Optional)**

A 1 x 4-pin legacy-style 2 mm connector connects an internal CD-ROM drive to the audio mixer.

**1.11.3.2 ATAPI CD-ROM Audio Connector**

A 1 x 4-pin ATAPI connector connects an internal CD-ROM drive to the audio mixer.

**1.11.3.3 Auxiliary Line In Connector (Optional)**

A 1 x 4-pin ATAPI-style connector connects the left and right channel signals of an internal audio device to the audio subsystem.

**1.11.3.4 Telephony Connector (Optional)**

A 1 x 4-pin ATAPI-style connector connects the monaural audio signals of an internal telephony device to the audio subsystem. A monaural audio-in and audio-out signal interface is necessary for telephony applications such as speakerphones, fax/modems, and answering machines.

**1.11.3.5 Video Source Line In Connector (Optional)**

A 1 x 4 pin ATAPI style connector connects the left and right audio channel signals of an internal video device to the audio subsystem. An audio-in signal interface of this type is necessary for applications such as TV tuners.

**1.12 Hardware Management Features (Optional)**

The optional hardware management features enable the board to be compatible with the Wired for Management (WfM) specification. The board has several hardware management features, including the following:

- Hardware monitor component
- Alert on LAN component
- Chassis intrusion detection
- Fan control and monitoring (implemented on the SMSC LPC47B272 I/O controller)

### 1.12.1 Hardware Monitor Component

The optional hardware monitor component provides low-cost instrumentation capabilities. The features of the component include:

- Internal ambient temperature sensing
- Remote thermal diode sensing for direct monitoring of processor temperature
- Power supply monitoring (+12, +5, +3.3, +2.5, VCCP) to detect levels above or below acceptable values
- SMBus interface

### 1.12.2 Alert on LAN Component

The optional Alert on LAN component is a companion device to the 82559 LAN controller. Together, the two devices provide a management interface between a remote console (or management server) and the client system monitoring instrumentation (the ICH and/or the hardware monitor component). The functions of the alert on LAN component include:

- Sending alert (SOS), heartbeat, or pong (ping response) packets to the 82559 LAN controller
- Receiving specially filtered packets needed for advanced power management modes such as reset, power-up, or power-down

### 1.12.3 Chassis Intrusion Detect Connector

The board supports a chassis security feature that detects if the chassis cover is removed and sounds an alarm (through the onboard speaker or PC chassis speaker, if either is present). For the chassis intrusion circuit to function, the chassis' power supply must be connected to AC power. The security feature uses a mechanical switch on the chassis that attaches to the chassis intrusion detect connector. The mechanical switch is closed for normal computer operation.

## 1.13 SCSI Hard Drive Activity LED Connector (Optional)

The SCSI hard drive activity LED connector is a 1 x 2-pin connector that allows an add-in SCSI controller to use the same LED as the onboard IDE controller. This connector can be connected to the LED output of the add-in controller card. The LED will indicate when data is being read or written using the add-in controller. See Section 1.17.2 for the location and pinouts of the SCSI hard drive activity LED connector.

## 1.14 LAN Subsystem (Optional)

The Intel 82559 Fast Ethernet Wired for Management (WfM) PCI LAN subsystem provides both 10Base-T and 100Base-TX connectivity. Features include:

- 32-bit, 33 MHz direct bus mastering on the PCI bus
- Shared memory structure in the host memory that copies data directly to/from host memory
- 10Base-T and 100Base-TX capability using a single RJ-45 connector with connection and activity status LEDs
- IEEE 802.3 $\mu$  Auto-Negotiation for the fastest available connection
- Jumperless configuration; the LAN subsystem is completely software-configurable

### 1.14.1 Intel® 82559 LAN Controller

The Intel 82559 PCI LAN controller's features include:

- CSMA/CD Protocol Engine
- PCI bus interface
- DMA engine for movement of commands, status, and network data across the PCI bus
- Integrated physical layer interface, including:
  - Complete functionality necessary for the 10Base-T and 100Base-TX network interfaces; when in 10 Mbit/sec mode, the interface drives the cable directly
  - A complete set of Media Independent Interface (MII) management registers for control and status reporting
  - 802.3 $\mu$  Auto-Negotiation for automatically establishing the best operating mode when connected to other 10Base-T or 100Base-TX devices, whether half- or full-duplex capable
- Integrated power management features, including:
  - Support for APM
  - Support for Wake on LAN technology

### 1.14.2 LAN Subsystem Software

The Intel 82559 Fast Ethernet WfM PCI LAN software and drivers are available from Intel's World Wide Web site (see Section 6.1).

### 1.14.3 RJ-45 LAN Connector LEDs

Two LEDs are built into the RJ-45 LAN connector. Table 3 describes the LED states when the board is powered up and the LAN subsystem is operating.

**Table 3. RJ-45 LAN Connector LEDs**

| LED Color | LED State                 | Indicates   |
|-----------|---------------------------|---|
| Green     | Off                       | 10 Mbit/sec speed is selected.                                  |
|           | On                        | 100 Mbit/sec speed is selected.                                 |
| Yellow    | Off                       | LAN link is not established.                                    |
|           | On (steady state)         | LAN link is established.  |
|           | On (brighter and pulsing) | The computer is communicating with another computer on the LAN. |

## 1.15 Power Management Features

Power management is implemented at several levels, including:

- Software support:
  - Advanced Power Management (APM)
  - Advanced Configuration and Power Interface (ACPI)
- Hardware support:
  - Wake on LAN technology (optional)
  - Instantly Available technology
  - Resume on Ring

### 1.15.1 Software Support

The software support for power management includes:

- APM
- ACPI

If the board is used with an ACPI-aware operating system, the BIOS can provide ACPI support. Otherwise, it defaults to APM support.

### 1.15.1.1 APM

APM makes it possible for the computer to enter an energy saving standby mode. The standby mode can be initiated in the following ways:

- Time-out period specified in the BIOS Setup program
- Suspend/resume switch connected to the front panel sleep connector
- From the operating system, such as the Suspend menu item in Windows 95

In standby mode, the motherboard can reduce power consumption by spinning down hard drives, and reducing power to or turning off VESA<sup>†</sup> DPMS-compliant monitors. Power-management mode can be enabled or disabled in the BIOS Setup program.

While in standby mode, the system retains the ability to respond to external interrupts and service requests, such as incoming faxes or network messages. Any keyboard or mouse activity brings the system out of standby mode and immediately restores power to the monitor.

The BIOS enables APM by default; but the operating system must support an APM driver for the power-management features to work. For example, Windows 95 supports the power-management features upon detecting that APM is enabled in the BIOS.

### 1.15.1.2 ACPI

ACPI gives the operating system direct control over the power management and Plug and Play functions of a computer. The use of ACPI with this board requires the support of an operating system that provides full ACPI functionality. ACPI features include:

- Plug and Play (including bus and device enumeration) and APM functionality normally contained in the BIOS
- Power management control of individual devices, add-in boards (some add-in boards may require an ACPI-aware driver), video displays, and hard disk drives
- Methods for achieving less than 30-watt system operation in the Power On Suspend sleeping state, and less than 5-watt system operation in the Suspend to Disk sleeping state
- A Soft-off feature that enables the operating system to power off the computer
- Support for multiple wake up events (see Table 6 on page 30)
- Support for a front panel power and sleep mode switch. Table 4 lists the system states based on how long the power switch is pressed, depending on how ACPI is configured with an ACPI-aware operating system.

**Table 4. Effects of Pressing the Power Switch**

| If the system is in this state... | ...and the power switch is pressed for | ...the system enters this state |
|-----------------------------------|--|---------------------------------|
| Off (ACPI G2/S5 state)            | Less than four seconds                 | Power on                        |
| On (ACPI G0 state)                | Less than four seconds                 | Soft off/Suspend                |
| On (ACPI G0 state)                | More than four seconds                 | Fail safe power off             |
| Sleep (ACPI G1 state)             | Less than four seconds                 | Wake up                         |
| Sleep (ACPI G1 state)             | More than four seconds                 | Power off                       |

## ⇒ NOTE

The Wake on LAN technology connector at location J8A3 is only supported in APM mode. ACPI mode is not supported.

### 1.15.1.2.1 System States and Power States

Under ACPI, the operating system directs all system and device power state transitions. The operating system puts devices in and out of low-power states based on user preferences and knowledge of how devices are being used by applications. Devices that are not being used can be turned off. The operating system uses information from applications and user settings to put the system as a whole into a low-power state.

Table 5 lists the power states supported by the motherboard along with the associated system power targets. See the ACPI specification for a complete description of the various system and power states.

**Table 5. Power States and Targeted System Power**

| Global States  | Sleeping States  | CPU States      | Device States  | Targeted System Power*                                   |
|--|--|-----------------|--|--|
| G0 - working state   | S0 - working   | C0 - working    | D0 - working state   | Full power > 60 W  |
| G1 - sleeping state  | S1 - CPU stopped   | C1 - stop grant | D1, D2, D3- device specification specific.   | 5 W < power < 30 W                                       |
| G1 - sleeping state  | S3 - Suspend-to-RAM. Context saved to RAM.               | No power        | D3 - no power except for wake up logic.  | Power < 5W **  |
| G2/S5  | S5 - Soft off. Context not saved. Cold boot is required. | No power        | D3 - no power except for wake up logic.  | Power < 5 W **   |
| G3 - mechanical off. AC power is disconnected from the computer. | No power to the system.                                  | No power        | D3 - no power for wake up logic, except when provided by battery or external source. | No power to the system so that service can be performed. |

\* Total system power is dependent on the system configuration, including add-in boards and peripherals powered by the system chassis' power supply.

\*\* Dependent on the standby power consumption of wake-up devices used in the system.

### 1.15.1.2.2 Wake Up Devices and Events

Table 6 lists the devices or specific events that can wake the computer from specific states. Sleeping state S5 is the same for the wake up event.

**Table 6. Wake Up Devices and Events**

| These devices/events can wake up the computer... | ...from this state |
|--|--------------------|
| Power switch                                     | S1, S3, S5         |
| RTC alarm  | S1, S3, S5         |
| LAN  | S1, S3, S5         |
| Modem  | S1, S3, S5         |
| IR command                                       | S1                 |
| USB  | S1                 |
| PS/2 keyboard                                    | S1                 |
| PS/2 mouse                                       | S1                 |
| Sleep button                                     | S1                 |
| PME  | S1, S3, S5         |

### 1.15.1.2.3 Plug and Play

In addition to power management, ACPI provides controls and information so that the operating system can facilitate Plug and Play device enumeration and configuration. ACPI is used only to enumerate and configure motherboard devices that do not have other hardware standards for enumeration and configuration. PCI devices on the motherboard, for example, are not enumerated by ACPI.

## 1.15.2 Hardware Support

The board provides several hardware features that support power management, including:

- Wake on LAN technology (optional)
- Instantly Available technology
- Resume on Ring

Wake on LAN technology and Instantly Available technology require power from the +5 V standby line. The sections discussing these features describe the incremental standby power requirements for each.



### CAUTION

*If Wake on LAN and Instantly Available technology features are used, ensure that the power supply provides adequate +5 V standby current. Failure to do so can damage the power supply. The total amount of standby current required depends on the wake devices supported and manufacturing options.*

Resume on Ring enables telephony devices to access the computer when it is in a power-managed state. The method used depends on the type of telephony device (external or internal) and the power management mode being used (APM or ACPI).

## ⇒ NOTE

The use of Resume on Ring technology from an ACPI state requires the support of an operating system that provides full ACPI functionality.

### 1.15.2.1 Wake on LAN Technology

Wake on LAN technology enables remote wakeup of the computer through a network. The LAN subsystem, whether onboard or as a PCI bus network adapter, monitors network traffic at the Media Independent Interface. Upon detecting a Magic Packet<sup>†</sup> frame, the LAN subsystem asserts a wakeup signal that powers up the computer. Depending on the LAN implementation, the motherboard board supports Wake on LAN technology in one of two ways:

- Through the Wake on LAN technology connector
- Through the PCI bus PME# signal (for PCI 2.2 compliant LAN designs)

The Wake on LAN technology connector can be used with PCI bus network adapters that have a remote wake up connector, as shown in Figure 4. Network adapters that are PCI 2.2 compliant assert the wakeup signal through the PCI bus signal PME# (pin A19 on the PCI bus connectors). The optional onboard LAN subsystem also supports remote wakeup using the PME# signal.

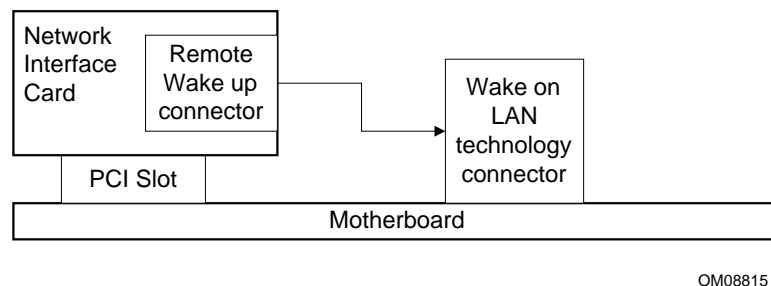

**Figure 4. Using the Wake on LAN Technology Connector**



## CAUTION

For Wake on LAN technology, the 5-V standby line for the power supply must be capable of delivering +5 V  $\pm$  5% at 720 mA. Failure to provide adequate standby current when implementing Wake on LAN technology can damage the power supply.

### 1.15.2.2 Instantly Available Technology

Instantly Available technology enables the board to enter the ACPI S3 (Suspend-to-RAM) sleep state. While in the S3 sleep state, the computer will appear to be off. When signaled by a wake up device or even, the system quickly returns to its last known wake state. Table 6 on page 30 lists the devices and events that can wake the computer from the S3 state.

The board supports the PCI Bus Power Management Interface Specification and the 3.3V Aux ECR. Add-in boards that also support these specifications can participate in power management and can be used to wake the computer.

The optional standby power indicator (located between the IDE connectors and power connector) provides an indication that power is still present to the DIMMs and PCI bus connectors, even when the computer appears to be off. Figure 5 shows the location of the standby power LED.

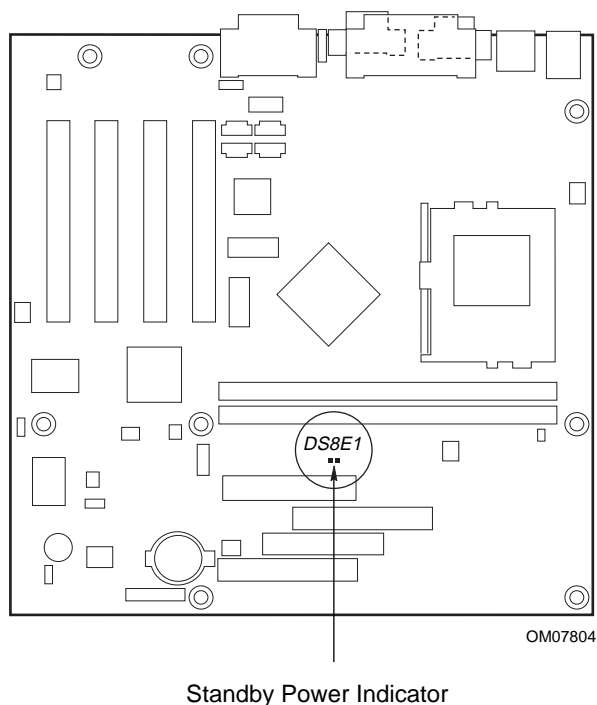

**Figure 5. Location of Standby Power Indicator LED**



#### **CAUTION**

*For Instantly Available technology, the power supply must be capable of providing the +5 V standby current that those boards require in addition to the standby current required by the motherboard. Failure to provide adequate standby current when using this feature can damage the power supply. Refer to Section 1.20.2 for more information.*

### 1.15.2.3 Resume on Ring

The operation of Resume on Ring can be summarized as follows:

- Resumes operation from either the APM sleep mode or the ACPI S1 state
- Requires only one call to access the computer
- Detects incoming call similarly for external and internal modems; does not use the Wake on Ring connector
- Requires modem interrupt be unmasked for correct operation

## 1.16 Fan Connectors

The board has three fan connectors, one being a manufacturing option. The functions of these connectors are:

- The processor fan (fan 3) connector provides +12 V DC for a processor fan or active fan heatsink.
- The chassis fan (fan 1) connector provides a high/low control signal for a fan located inside of and powered by the system power supply.
- The front panel fan (fan 2) connector is optional.

## 1.17 Motherboard Connectors

This section describes the motherboard's connectors. The connectors can be divided into three groups, as shown in Figure 6.

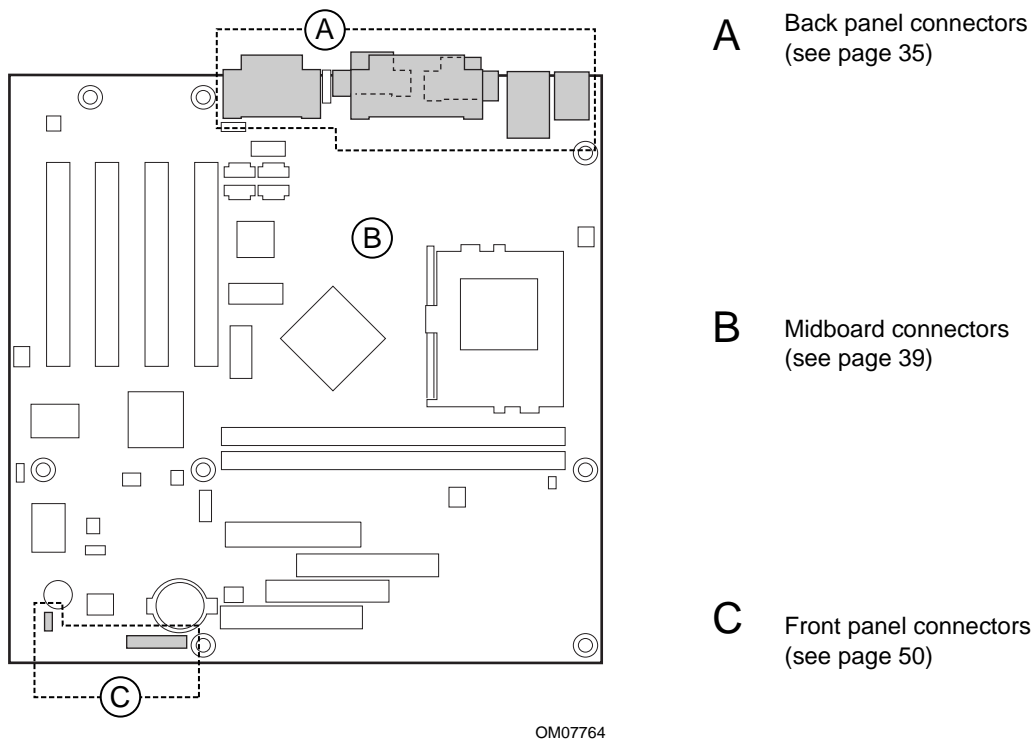

**Figure 6. Connector Groups**



### CAUTION

*Only the back panel connectors of this motherboard have overcurrent protection. The internal motherboard connectors do not have overcurrent protection; they should connect only to devices inside the computer chassis, such as fans and internal peripherals. Do not use these connectors for powering devices external to the computer chassis. A fault in the load presented by the external devices could cause damage to the computer, the interconnecting cable, and the external devices themselves.*

### 1.17.1 Back Panel Connectors

Figure 7 shows the location of the back panel connectors.

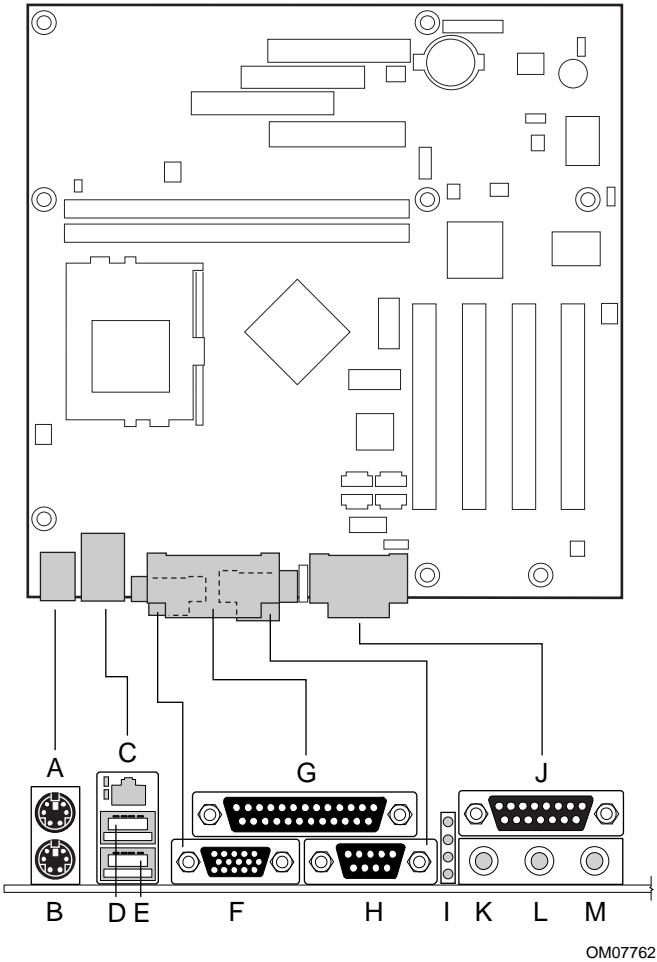

- |   |                        |   |                                      |
|---|------------------------|---|--------------------------------------|
| A | PS/2 keyboard or mouse | H | Serial port A                        |
| B | PS/2 keyboard or mouse | I | Enhanced diagnostics LEDs (optional) |
| C | RJ-45 LAN (optional)   | J | MIDI/Game port                       |
| D | USB port 0 (optional)  | K | Audio line-out                       |
| E | USB port 1 (optional)  | L | Audio line-in                        |
| F | VGA port               | M | Mic in                               |
| G | Parallel port          |   |                                      |

Figure 7. Back Panel Connectors and Indicators

**Table 7. PS/2 Keyboard/Mouse Connectors**

| Pin | Signal        |
|-----|---------------|
| 1   | Data          |
| 2   | Not connected |
| 3   | Ground        |
| 4   | Fused +5 V    |
| 5   | Clock         |
| 6   | Not connected |

**Table 8. RJ-45 LAN Connector (optional)**

| Pin | Signal Name |
|-----|-------------|
| 1   | TxD +       |
| 2   | TxD -       |
| 3   | RxD +       |
| 4   | Ground      |
| 5   | Ground      |
| 6   | RxD -       |
| 7   | Ground      |
| 8   | Ground      |

**Table 9. USB Connectors**

| Pin | Signal                              |
|-----|-------------------------------------|
| 1   | Fused +5 V                          |
| 2   | 3.3V differential USB signal USB_D- |
| 3   | 3.3V differential USB signal USB_D+ |
| 4   | Ground                              |

**Table 10. Serial Port Connector**

| Pin | Signal                    |
|-----|---------------------------|
| 1   | DCD (Data Carrier Detect) |
| 2   | SIN# (Serial Data In)     |
| 3   | SOUT# (Serial Data Out)   |
| 4   | DTR (Data Terminal Ready) |
| 5   | Ground                    |
| 6   | DSR (Data Set Ready)      |
| 7   | RTS (Request to Send)     |
| 8   | CTS (Clear to Send)       |
| 9   | RI (Ring Indicator)       |

**Table 11. Parallel Port Connector**

| Pin     | Std Signal | ECP Signal           | EPP Signal | I/O |
|---------|------------|----------------------|------------|-----|
| 1       | STROBE#    | STROBE#              | WRITE#     | I/O |
| 2       | PD0        | PD0                  | PD0        | I/O |
| 3       | PD1        | PD1                  | PD1        | I/O |
| 4       | PD2        | PD2                  | PD2        | I/O |
| 5       | PD3        | PD3                  | PD3        | I/O |
| 6       | PD4        | PD4                  | PD4        | I/O |
| 7       | PD5        | PD5                  | PD5        | I/O |
| 8       | PD6        | PD6                  | PD6        | I/O |
| 9       | PD7        | PD7                  | PD7        | I/O |
| 10      | ACK#       | ACK#                 | INTR       | I   |
| 11      | BUSY       | BUSY#, PERIPHACK     | WAIT#      | I   |
| 12      | PERROR     | PE, ACKREVERSE#      | PE         | I   |
| 13      | SELECT     | SELECT               | SELECT     | I   |
| 14      | AUDOFD#    | AUDOFD#, HOSTACK     | DATASTB#   | O   |
| 15      | FAULT#     | FAULT#, PERIPHREQST# | FAULT#     | I   |
| 16      | INIT#      | INIT#, REVERSERQST#  | RESET#     | O   |
| 17      | SLCTIN#    | SLCTIN#              | ADDRSTB#   | O   |
| 18 - 25 | GND        | GND                  | GND        | -   |

**Table 12. VGA Connector**

| Pin | Signal        |
|-----|---------------|
| 1   | RED           |
| 2   | GREEN         |
| 3   | BLUE          |
| 4   | Not connected |
| 5   | GND           |
| 6   | GND           |
| 7   | GND           |
| 8   | GND           |
| 9   | FUSED VCC     |
| 10  | GND           |
| 11  | Not connected |
| 12  | DDC_SDA       |
| 13  | HSYNC         |
| 14  | VSYNC         |
| 15  | DDC_SCL       |

**Table 13. MIDI/Game Port Connector**

| Pin | Signal Name  | Pin | Signal Name  |
|-----|--------------|-----|--------------|
| 1   | +5 V (fused) | 9   | +5 V (fused) |
| 2   | GP4 (JSBUT0) | 10  | GP6 (JSBUT2) |
| 3   | GP0 (JSX1)   | 11  | GP2 (JSX2)   |
| 4   | Ground       | 12  | MIDI-OUT     |
| 5   | Ground       | 13  | GP3 (JSY2)   |
| 6   | GP1 (JSY1)   | 14  | GP7 (JSBUT3) |
| 7   | GP5 (JSBUT1) | 15  | MIDI-IN      |
| 8   | +5 V (fused) |     |              |

**Table 14. Audio Line-In Connector**

| Pin    | Signal         |
|--------|----------------|
| Tip    | Audio left in  |
| Ring   | Audio right in |
| Sleeve | Ground         |

**Table 15. Audio Line-Out Connector**

| Pin    | Signal          |
|--------|-----------------|
| Tip    | Audio left out  |
| Ring   | Audio right out |
| Sleeve | Ground          |

**Table 16. Audio Mic-In Connector**

| Pin    | Signal           |
|--------|------------------|
| Tip    | Mono in          |
| Ring   | Mic bias voltage |
| Sleeve | Ground           |

## 1.17.2 Midboard Connectors

The midboard connectors are divided into the following functional groups:

- Audio (see page 40)
  - Auxiliary line-in (optional)
  - CD-ROM (ATAPI-style)
  - CD-ROM (Legacy-style)
  - Telephony (optional)
  - Video source line-in (optional)
- Peripheral interfaces (see page 42)
  - USB front panel (optional)
  - SCSI HD activity LED (optional)
  - Diskette drive
  - IDE (2)
  - Serial port B
- Hardware Management and Power (see page 45)
  - Chassis intrusion (optional)
  - Fans (3)
  - Power
  - Wake on LAN technology (optional)
- PCI bus add-in boards (see page 48)

### 1.17.2.1 Audio

Figure 8 shows the location of the audio connectors.

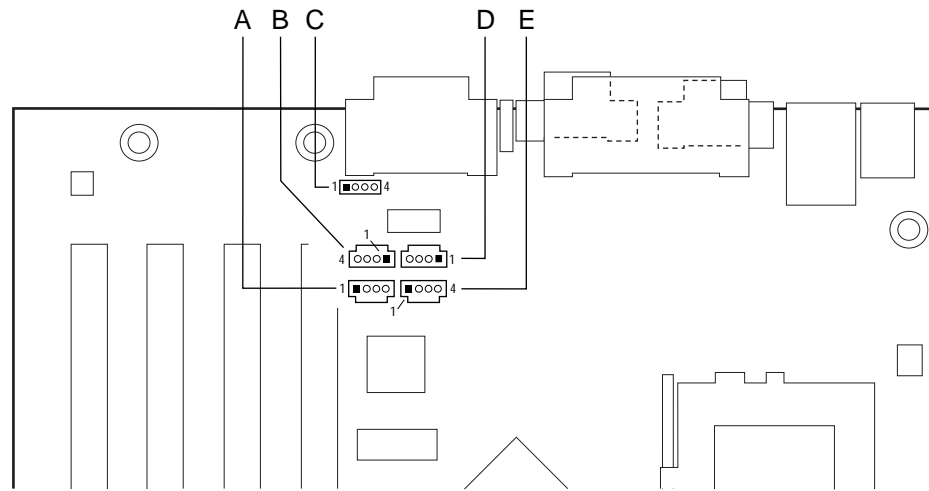

OM07771

| Item | Description                     | Color   | Style        | Reference Designator |
|------|---------------------------------|---------|--------------|----------------------|
| A    | CD-ROM                          | black   | ATAPI        | J2C2                 |
| B    | Video source line-in (optional) | blue    | ATAPI        | J2C1                 |
| C    | CD-ROM (optional)               | white   | Legacy, 2 mm | J1C1                 |
| D    | Auxiliary line-in (optional)    | natural | ATAPI        | J2D2                 |
| E    | Telephony (optional)            | green   | ATAPI        | J2D3                 |

**Figure 8. Midboard Audio Connectors**

**Table 17. ATAPI CD-ROM Connector (J2C2)**

| Pin | Signal                        |
|-----|-------------------------------|
| 1   | Left audio input from CD-ROM  |
| 2   | CD audio differential ground  |
| 3   | CD audio differential ground  |
| 4   | Right audio input from CD-ROM |

**Table 18. Optional Video Source Line In Connector (J2C1)**

| Pin | Signal                  |
|-----|-------------------------|
| 1   | Left auxiliary line in  |
| 2   | Ground                  |
| 3   | Ground                  |
| 4   | Right auxiliary line in |

**Table 19. Optional Legacy CD-ROM Connector (J1C1)**

| Pin | Signal                        |
|-----|-------------------------------|
| 1   | CD audio differential ground  |
| 2   | Left audio input from CD-ROM  |
| 3   | CD audio differential ground  |
| 4   | Right audio input from CD-ROM |

**Table 20. Optional Auxiliary Line In Connector (J2D2)**

| Pin | Signal                  |
|-----|-------------------------|
| 1   | Left auxiliary line in  |
| 2   | Ground                  |
| 3   | Ground                  |
| 4   | Right auxiliary line in |

**Table 21. Optional Telephony Connector (J2D3)**

| Pin | Signal                   |
|-----|--------------------------|
| 1   | Analog audio mono input  |
| 2   | Ground                   |
| 3   | Ground                   |
| 4   | Analog audio mono output |

### 1.17.2.2 Peripheral Interfaces

Figure 9 shows the location of the peripheral interface connectors.

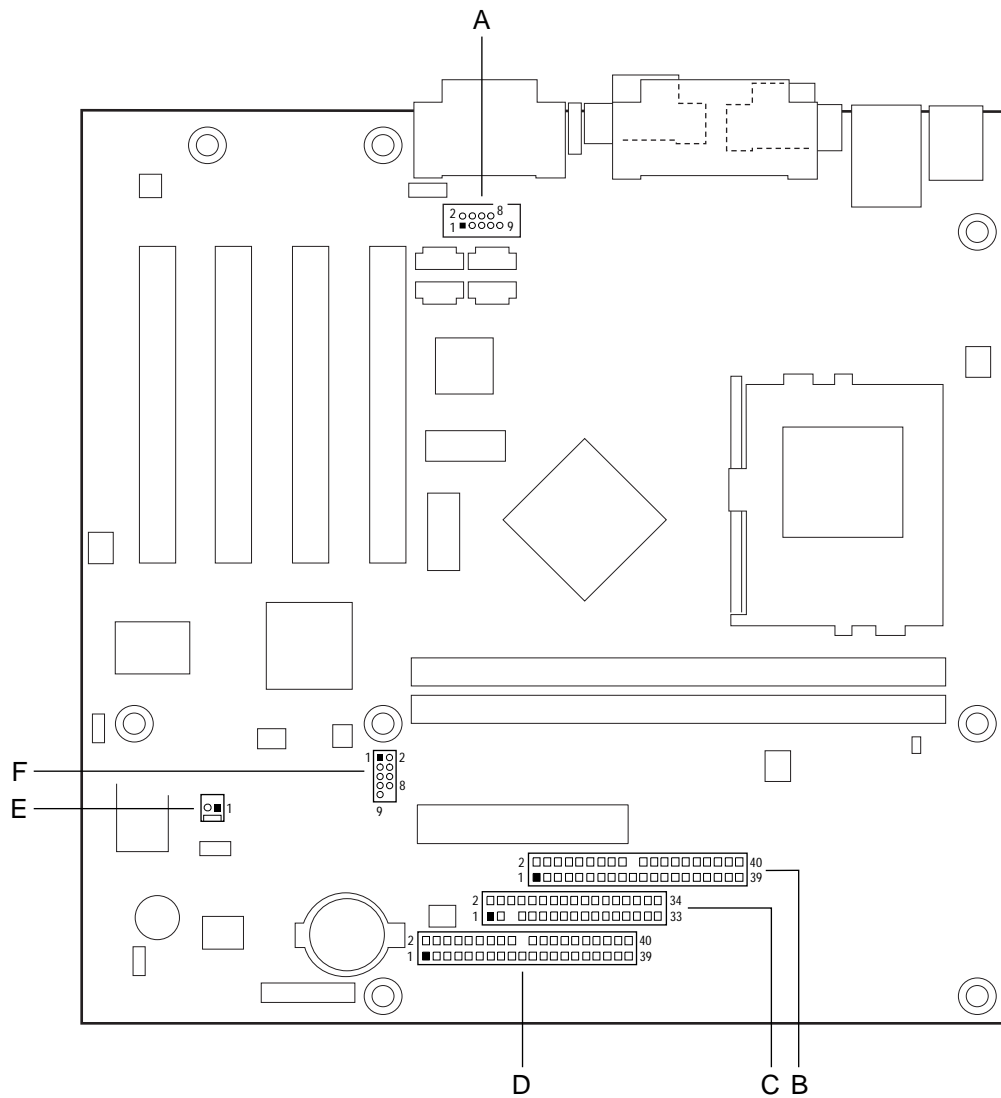

OM07770

- |   |                |   |   |
|---|----------------|---|---|
| A | Serial port B  | D | Primary IDE                             |
| B | Secondary IDE  | E | SCSI hard drive activity LED (optional) |
| C | Diskette drive | F | USB front panel (optional)              |

**Figure 9. Peripheral Interface Connectors**

**Table 22. Serial Port B Connector (J2D1)**

| Pin | Signal                    | Pin | Signal                |
|-----|---------------------------|-----|-----------------------|
| 1   | DCD Data Carrier Detect)  | 2   | DSR (Data Set Ready)  |
| 3   | SIN# Serial Data In)      | 4   | RTS (Request to Send) |
| 5   | SOUT# (Serial Data Out)   | 6   | CTS (Clear to Send)   |
| 7   | DTR (Data Terminal Ready) | 8   | RI (Ring Indicator)   |
| 9   | Ground                    |     |                       |

**Table 23. Optional USB Front Panel Connector (J8C1)**

| Pin | Signal     | Pin | Signal      |
|-----|------------|-----|-------------|
| 1   | TP_FPUSB_1 | 2   | VCC         |
| 3   | Ground     | 4   | TP_FUSB_4   |
| 5   | TP_FPUSB_5 | 6   | FNT_USBPO   |
| 7   | Ground     | 8   | FNT_USBPO # |
| 9   | Ground     |     |             |

**Table 24. Optional SCSI Hard Drive Activity LED Connector (J8A2) (optional)**

| Pin | Signal        |
|-----|---------------|
| 1   | SCSI activity |
| 2   | Not connected |

**Table 25. Diskette Drive Connector (J9E1)**

| Pin | Signal     | Pin | Signal                           |
|-----|------------|-----|----------------------------------|
| 1   | Ground     | 2   | DENSEL                           |
| 3   | Ground     | 4   | Reserved                         |
| 5   | Key        | 6   | FDEDIN                           |
| 7   | Ground     | 8   | FDINDX# (Index)                  |
| 9   | Ground     | 10  | FDM00# (Motor Enable A)          |
| 11  | Ground     | 12  | No connect                       |
| 13  | Ground     | 14  | FDSD0# (Drive Select A)          |
| 15  | Ground     | 16  | No connect                       |
| 17  | No connect | 18  | FDDIR# (Stepper Motor Direction) |
| 19  | Ground     | 20  | FDSTEP# (Step Pulse)             |
| 21  | Ground     | 22  | FDWD# (Write Data)               |
| 23  | Ground     | 24  | FDWE# (Write Enable)             |
| 25  | Ground     | 26  | FDTRK0# (Track 0)                |
| 27  | No connect | 28  | FDWPD# (Write Protect)           |
| 29  | Ground     | 30  | FDRDATA# (Read Data)             |
| 31  | Ground     | 32  | FDHEAD# (Side 1 Select)          |
| 33  | Ground     | 34  | DSKCHG# (Diskette Change)        |

**Table 26. PCI IDE Connectors (J9D1, J9F1)**

| Pin | Signal                            | Pin | Signal                            |
|-----|-----------------------------------|-----|-----------------------------------|
| 1   | Reset IDE                         | 2   | Ground                            |
| 3   | Data 7                            | 4   | Data 8                            |
| 5   | Data 6                            | 6   | Data 9                            |
| 7   | Data 5                            | 8   | Data 10                           |
| 9   | Data 4                            | 10  | Data 11                           |
| 11  | Data 3                            | 12  | Data 12                           |
| 13  | Data 2                            | 14  | Data 13                           |
| 15  | Data 1                            | 16  | Data 14                           |
| 17  | Data 0                            | 18  | Data 15                           |
| 19  | Ground                            | 20  | Key                               |
| 21  | DDRQ0 [DDRQ1]                     | 22  | Ground                            |
| 23  | I/O Write#                        | 24  | Ground                            |
| 25  | I/O Read#                         | 26  | Ground                            |
| 27  | IOCHRDY                           | 28  | P_ALE (Cable Select pull-up)      |
| 29  | DDACK0# [DDACK1#]                 | 30  | Ground                            |
| 31  | IRQ 14 [IRQ 15]                   | 32  | Reserved                          |
| 33  | DAG1 (Address 1)                  | 34  | Reserved                          |
| 35  | DAG0 (Address 0)                  | 36  | DAG2Address 2                     |
| 37  | Chip Select 1P# [Chip Select 1S#] | 38  | Chip Select 3P# [Chip Select 3S#] |
| 39  | Activity#                         | 40  | Ground                            |

NOTE: Signal names in brackets ( [ ] ) are for the secondary IDE connector.

### 1.17.2.3 Hardware Management and Power

Figure 10 shows the location of the hardware management and power connectors.

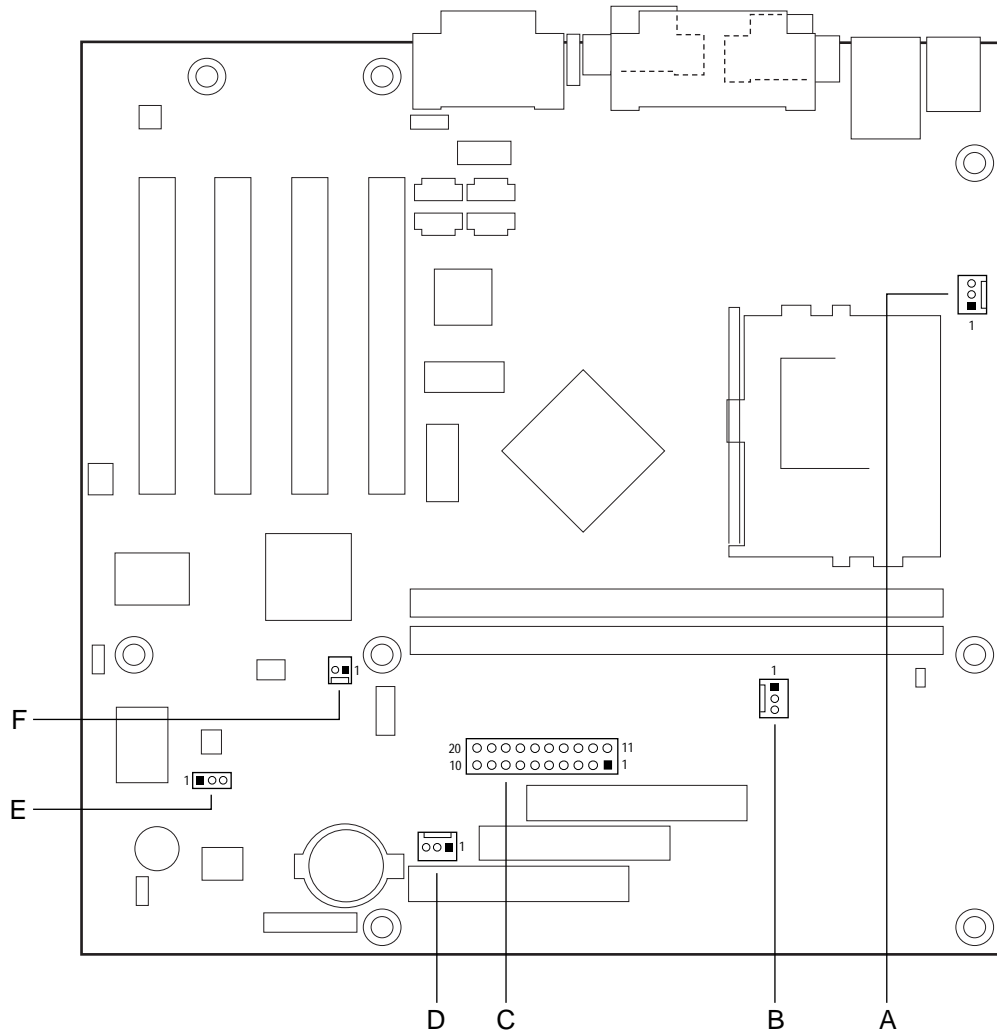

OM07769

- |   |                   |   |                                   |
|---|-------------------|---|-----------------------------------|
| A | Fan 3 (processor) | D | Fan 1 (chassis)                   |
| B | Fan 2 (optional)  | E | Wake on LAN technology (optional) |
| C | Power             | F | Chassis intrusion (optional)      |

**Figure 10. Hardware Management and Power Connectors**

**Table 27. Fan 3 (Processor) Connector (J3J1)**

| Pin | Signal |
|-----|--------|
| 1   | Ground |
| 2   | +12 V  |
| 3   | Ground |

**Table 28. Optional Fan 2 Connector (J7G1)**

| Pin | Signal        |
|-----|---------------|
| 1   | Ground        |
| 2   | +12 V (FAN_C) |
| 3   | Tach          |

**Table 29. Power Connector (J8D1)**

| Pin | Signal                               | Pin | Signal                              |
|-----|--------------------------------------|-----|-------------------------------------|
| 1   | +3.3 V                               | 11  | +3.3 V                              |
| 2   | +3.3 V                               | 12  | -12 V                               |
| 3   | Ground                               | 13  | Ground                              |
| 4   | +5 V                                 | 14  | PS-ON# (power supply remote on/off) |
| 5   | Ground                               | 15  | Ground                              |
| 6   | +5 V                                 | 16  | Ground                              |
| 7   | Ground                               | 17  | Ground                              |
| 8   | PWRGD (Power Good)                   | 18  | -5 V                                |
| 9   | +5 VSB (Standby for real-time clock) | 19  | +5 V                                |
| 10  | +12 V                                | 20  | +5 V                                |

**⇒ NOTE**

*The standard SFX 90 W power supply is not sufficient for the CA810 motherboard. For more information, see Power Consumption on page 57.*

**Table 30. Fan 1 (Chassis Fan) Connector (J9C1)**

| Pin | Signal        |
|-----|---------------|
| 1   | Ground        |
| 2   | +12 V (FAN_C) |
| 3   | Tach          |

**Table 31. Optional Wake on LAN Technology Connector (J8A3)**

| Pin | Signal |
|-----|--------|
| 1   | +5 VSB |
| 2   | Ground |
| 3   | WOL    |

**Table 32. Optional Chassis Intrusion Connector (J7B1)**

| Pin | Signal       |
|-----|--------------|
| 1   | CHS_SECURITY |
| 2   | Ground       |

### 1.17.2.4 PCI Bus Add-In Board Connectors

Figure 11 shows the location of the add-in board connectors. Note the following considerations for the PCI bus connectors:

- All of the PCI bus connectors are bus master capable
- PCI bus connector 2 has optional SMBus signals routed to it. This enables PCI bus add-in boards with SMBus support to access sender data on the motherboard. The specific SMBus signals are as follows:
  - The SMBus clock line is connected to pin A40
  - The SMBus data line is connected to pin A41

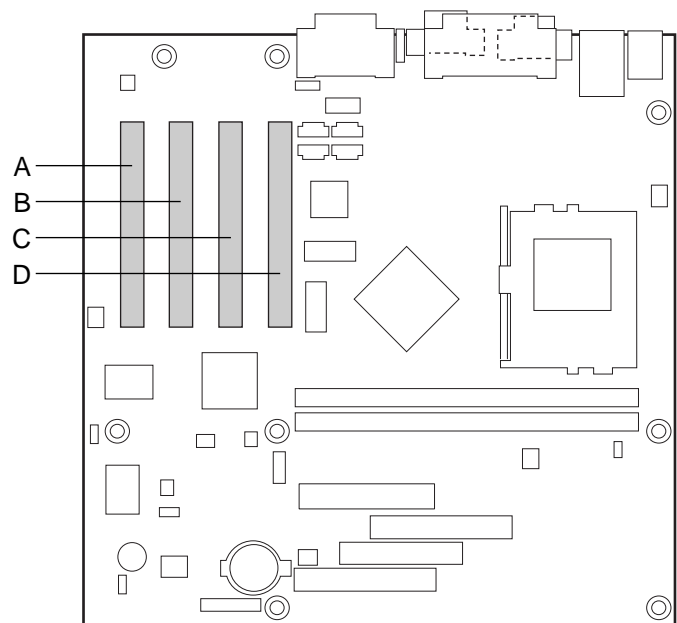

OM07759

- A PCI slot 4
- B PCI slot 3
- C PCI slot 2
- D PCI slot 1

**Figure 11. PCI Bus Add-In Board Connectors**

Table 33. PCI Bus Connectors

| Pin | Signal          | Pin | Signal                | Pin | Signal      | Pin | Signal     |
|-----|-----------------|-----|-----------------------|-----|-------------|-----|------------|
| A1  | Ground (TRST#)* | B1  | -12 V                 | A32 | AD16        | B32 | AD17       |
| A2  | +12 V           | B2  | Ground (TCK)*         | A33 | +3.3 V      | B33 | C/BE2#     |
| A3  | +5 V (TMS)*     | B3  | Ground                | A34 | FRAME#      | B34 | Ground     |
| A4  | +5 V (TDI)*     | B4  | no connect (TDO)*     | A35 | Ground      | B35 | IRDY#      |
| A5  | +5 V            | B5  | +5 V                  | A36 | TRDY#       | B36 | +3.3 V     |
| A6  | INTA#           | B6  | +5 V                  | A37 | Ground      | B37 | DEVSEL#    |
| A7  | INTC#           | B7  | INTB#                 | A38 | STOP#       | B38 | Ground     |
| A8  | +5 V            | B8  | INTD#                 | A39 | +3.3 V      | B39 | LOCK#      |
| A9  | Reserved        | B9  | no connect (PRSNT1#)* | A40 | Reserved**  | B40 | PERR#      |
| A10 | +5 V (I/O)      | B10 | Reserved              | A41 | Reserved*** | B41 | +3.3 V     |
| A11 | Reserved        | B11 | no connect (PRSNT2#)* | A42 | Ground      | B42 | SERR#      |
| A12 | Ground          | B12 | Ground                | A43 | PAR         | B43 | +3.3 V     |
| A13 | Ground          | B13 | Ground                | A44 | AD15        | B44 | C/BE1#     |
| A14 | +3.3 V aux      | B14 | Reserved              | A45 | +3.3 V      | B45 | AD14       |
| A15 | RST#            | B15 | Ground                | A46 | AD13        | B46 | Ground     |
| A16 | +5 V (I/O)      | B16 | CLK                   | A47 | AD11        | B47 | AD12       |
| A17 | GNT#            | B17 | Ground                | A48 | Ground      | B48 | AD10       |
| A18 | Ground          | B18 | REQ#                  | A49 | AD09        | B49 | Ground     |
| A19 | PME#            | B19 | +5 V (I/O)            | A50 | Key         | B50 | Key        |
| A20 | AD30            | B20 | AD31                  | A51 | Key         | B51 | Key        |
| A21 | +3.3 V          | B21 | AD29                  | A52 | C/BE0#      | B52 | AD08       |
| A22 | AD28            | B22 | Ground                | A53 | +3.3 V      | B53 | AD07       |
| A23 | AD26            | B23 | AD27                  | A54 | AD06        | B54 | +3.3 V     |
| A24 | Ground          | B24 | AD25                  | A55 | AD04        | B55 | AD05       |
| A25 | AD24            | B25 | +3.3 V                | A56 | Ground      | B56 | AD03       |
| A26 | IDSEL           | B26 | C/BE3#                | A57 | AD02        | B57 | Ground     |
| A27 | +3.3 V          | B27 | AD23                  | A58 | AD00        | B58 | AD01       |
| A28 | AD22            | B28 | Ground                | A59 | +5 V (I/O)  | B59 | +5 V (I/O) |
| A29 | AD20            | B29 | AD21                  | A60 | REQ64C#     | B60 | ACK64C#    |
| A30 | Ground          | B30 | AD19                  | A61 | +5 V        | B61 | +5 V       |
| A31 | AD18            | B31 | +3.3 V                | A62 | +5 V        | B62 | +5 V       |

\* These signals (in parentheses) are optional in the PCI specification and are not currently implemented.

\*\* On PCI bus connector 2, this pin is connected to the optional SMBus clock line.

\*\*\* On PCI bus connector 2, this pin is connected to the optional SMBus data line.

### 1.17.3 Front Panel Connectors

Figure 12 shows the location of the front panel connectors, and Table 34 lists the connector signals.

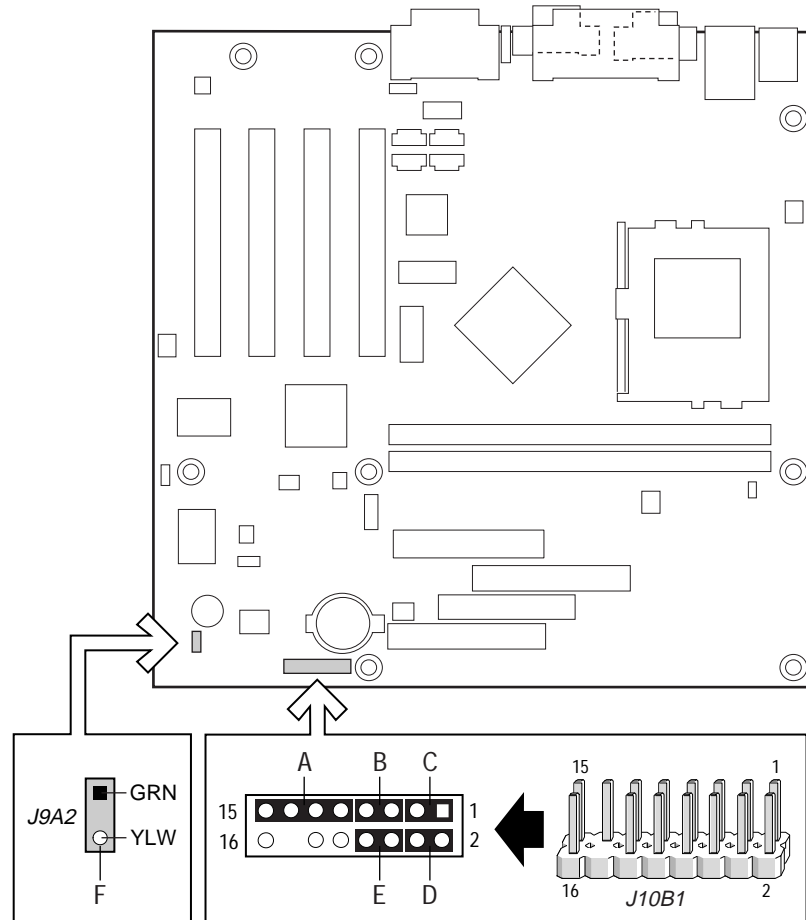

OM07767

|   |                         |   |               |
|---|-------------------------|---|---------------|
| A | Infrared Port           | D | Power LED     |
| B | Reset Switch            | E | On/Off Switch |
| C | Hard Drive Activity LED | F | Power LED     |

**Figure 12. Front Panel Connectors**

**Table 34. Front Panel Connector (J10B1)**

| Pin | Signal    | In/Out | Description                                   | Pin | Signal        | In/Out | Description               |
|-----|-----------|--------|---|-----|---------------|--------|---------------------------|
| 1   | HD_PWR    | Out    | Hard disk LED pull-up (330 $\Omega$ ) to +5 V | 2   | HDR_BLNK_GRN  | Out    | Front panel green LED     |
| 3   | HDA#      | Out    | Hard disk active LED                          | 4   | HDR_BLNK_YEL  | Out    | Front panel yellow LED    |
| 5   | GND       |        | Ground  | 6   | FPBUT_IN      | In     | Front panel On/Off button |
| 7   | FP_RESET# | In     | Front panel Reset button                      | 8   | GND           |        | Ground                    |
| 9   | +5 V      | Out    | IR Power                                      | 10  | N/C           | In     | Not connected             |
| 11  | IRRX      | In     | IrDA serial input                             | 12  | GND           |        | Ground                    |
| 13  | GND       |        | Ground  | 14  | (pin removed) |        | Not connected             |
| 15  | IRTX      | Out    | IrDA serial output                            | 16  | +5 V          | Out    | Power                     |

Pins 1 and 3 can be connected to an LED to provide a visual indicator that data is being read from or written to a hard drive. For the LED to function properly, an IDE drive must be connected to the onboard hard drive controller.

Pins 2 and 4 can be connected either a single or dual colored LED that will light when the computer is powered on. Table 35 and Table 36 show the possible states for these LEDs.

**Table 35. Power LED (Single-colored)**

| LED State      | Description                       |
|----------------|-----------------------------------|
| Off            | Off                               |
| Steady Green   | Running                           |
| Blinking Green | Running or message waiting (Note) |

Note: To utilize the message waiting function, an OnNow / Instantly Available aware message capturing software application must be invoked.

**Table 36. Power LED (Dual-colored)**

| LED State       | Description                        |
|-----------------|------------------------------------|
| Off             | Off                                |
| Steady Green    | Running                            |
| Blinking Green  | Running or message waiting (Note)  |
| Steady Yellow   | Sleeping                           |
| Blinking Yellow | Sleeping or message waiting (Note) |

Note: To utilize the message waiting function, an OnNow / Instantly Available aware message capturing software application must be invoked.

Pins 6 and 8 can be connected to a momentary SPST type switch that is normally open. The switch must pull the SW\_ON# pin to ground for at least 50 ms to signal the power supply to switch on or off. (The time requirement is due to internal debounce circuitry on the motherboard.) At least two seconds must pass before the power supply will recognize another on/off signal.

Pins 5 and 7 can be connected to a momentary SPST type switch that is normally open. When the switch is closed, the motherboard resets and runs the POST.

Pins 10 and 12 can be connected to a momentary SPST type switch that is normally open. When the switch is pressed and the power is on, the motherboard will toggle in or out of the sleep state.

Pins 11, and 13 - 16 can be connected to an IrDA module. After the IrDA interface is configured, files can be transferred to or from portable devices such as laptops, PDAs, and printers using application software.

Table 37 lists the signals for the power LED front panel connector.

**Table 37. Power LED Front Panel Connector (J9A2)**

| Pin | Signal       | In/Out | Description            |
|-----|--------------|--------|------------------------|
| 1   | HDR_BLNK_GRN | Out    | Front panel green LED  |
| 2   |              |        | Not connected          |
| 3   | HDR_BLNK_YEL | Out    | Front panel yellow LED |

Pins 1 and 3 can be connected to either a single or dual colored LED that will light when the computer is powered on. Table 35 and Table 36 show the possible states for these LEDs.

# 1.18 Jumper Blocks

The motherboard has two jumper blocks. Figure 13 shows the location of the motherboard's jumper blocks.

**CAUTION**

*Do not move any jumpers with the power on. Always turn off the power and unplug the power cord from the computer before changing a jumper. Otherwise, damage to the motherboard could occur.*

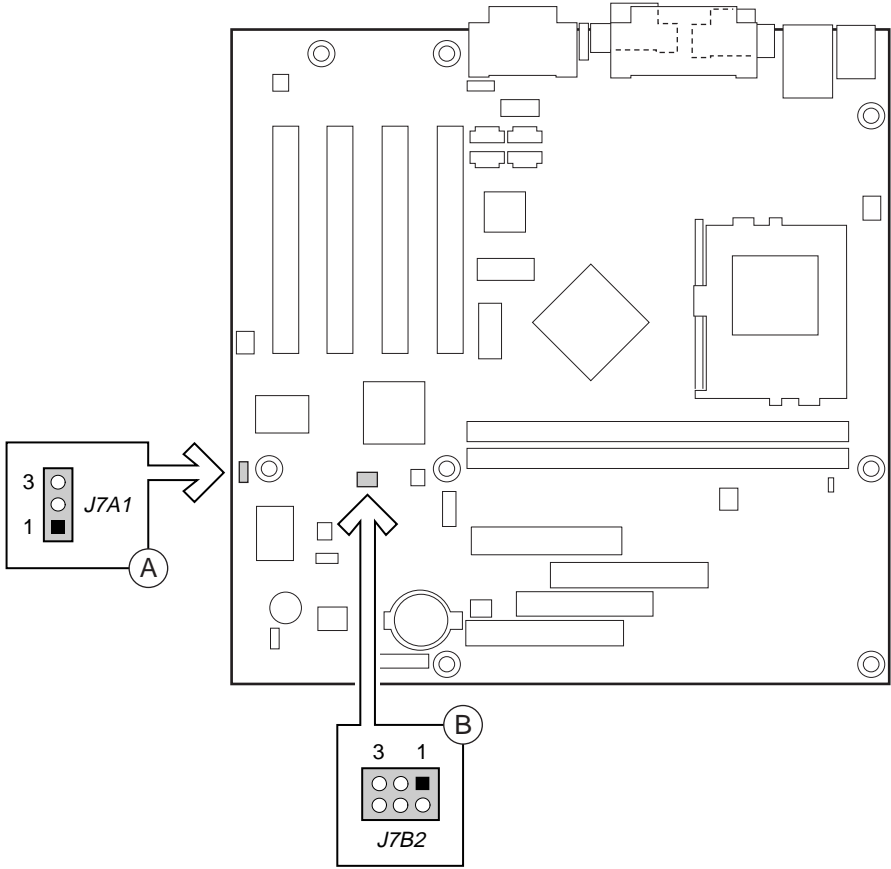

OM07760



- A BIOS setup configuration jumper block
- B USB Port 0 configuration jumper block (optional)

**Figure 13. Location of the Jumper Blocks**

### 1.18.1 BIOS Setup Configuration Jumper Block

This 3-pin jumper block enables all motherboard configuration to be done in BIOS Setup. Table 38 describes the jumper settings for normal, configure, and recovery modes.

**Table 38. BIOS Setup Configuration Jumper Settings**

| Function / Mode | Jumper Setting   | Configuration   |
|-----------------|--|---|
| Normal          | 1-2   | The BIOS uses current configuration information and passwords for booting.            |
| Configure       | 2-3   | After the POST runs, Setup runs automatically. The maintenance menu is displayed.     |
| Recovery        | none  | The BIOS attempts to recover the BIOS configuration. A recovery diskette is required. |

### 1.18.2 USB Port 0 Configuration Jumper Block (Optional)

This 6-pin jumper block allows rerouting of USB Port 0. Table 39 describes the jumper settings.

**Table 39. USB Port 0 Configuration Jumper Settings**

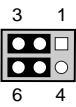
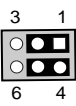
| Jumper Setting  | Configuration   |
|---|---|
| 2-3 and 5-6   | USB Port 0 signals are routed to the back panel               |
| 1-2 and 4-5  | USB Port 1 signals are routed for a front panel USB connector |

# 1.19 Mechanical Considerations

## 1.19.1 Form Factor

The motherboard is designed to fit into a microATX or a standard ATX form factor chassis. Figure 14 illustrates the mechanical form factor for the motherboard. Dimensions are given in inches. The outer dimensions are 9.6 x 9.6 inches. Location of the I/O connectors and mounting holes are in strict compliance with the microATX specification (see Section 6.2).

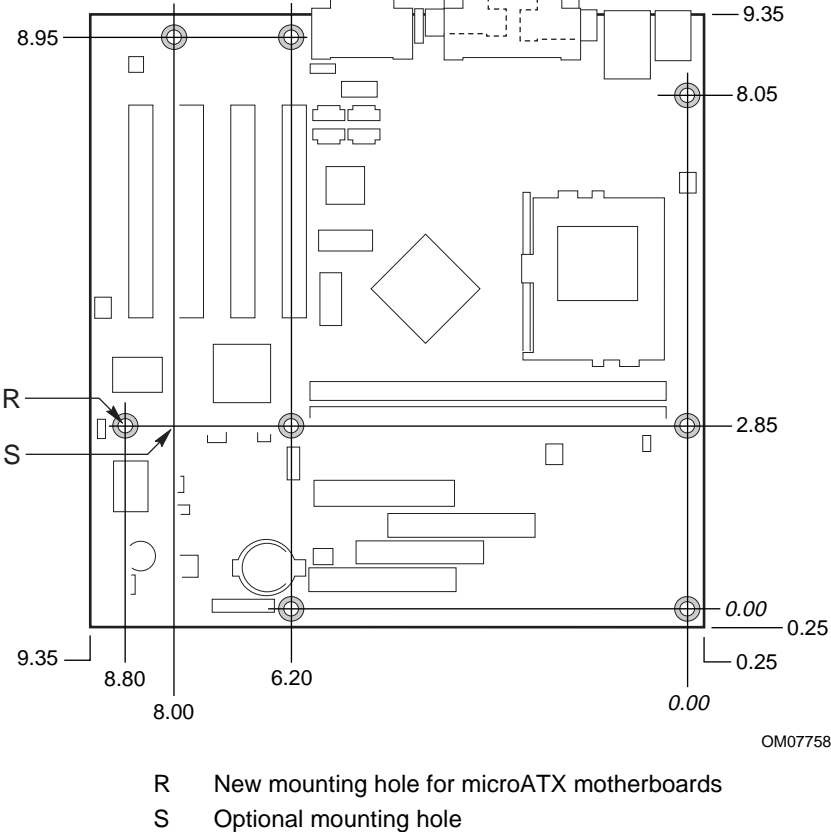

Figure 14. Motherboard Dimensions

**CAUTION**

As permitted by the microATX specification, the optional hole at location S in Figure 14 was omitted from the CA810 motherboard. The chassis standoff in this position should not be implemented or should be removable to avoid damage to traces on the motherboard.

### 1.19.2 I/O Shield

The back panel I/O shield for the motherboard must meet specific dimension and material requirements. Systems based on this motherboard need the back panel I/O shield to pass certification testing. Figure 15 shows the critical dimensions of the chassis-independent I/O shield. Dimensions are given in millimeters and [inches]. The figure indicates the position of each cutout. Additional design considerations for I/O shields relative to chassis requirements are described in the microATX specification.

⇒ **NOTE**

*A chassis-independent I/O shield designed to be compliant with the microATX chassis specification is available from Intel. The actual punchouts may differ depending on the motherboard manufacturing options.*

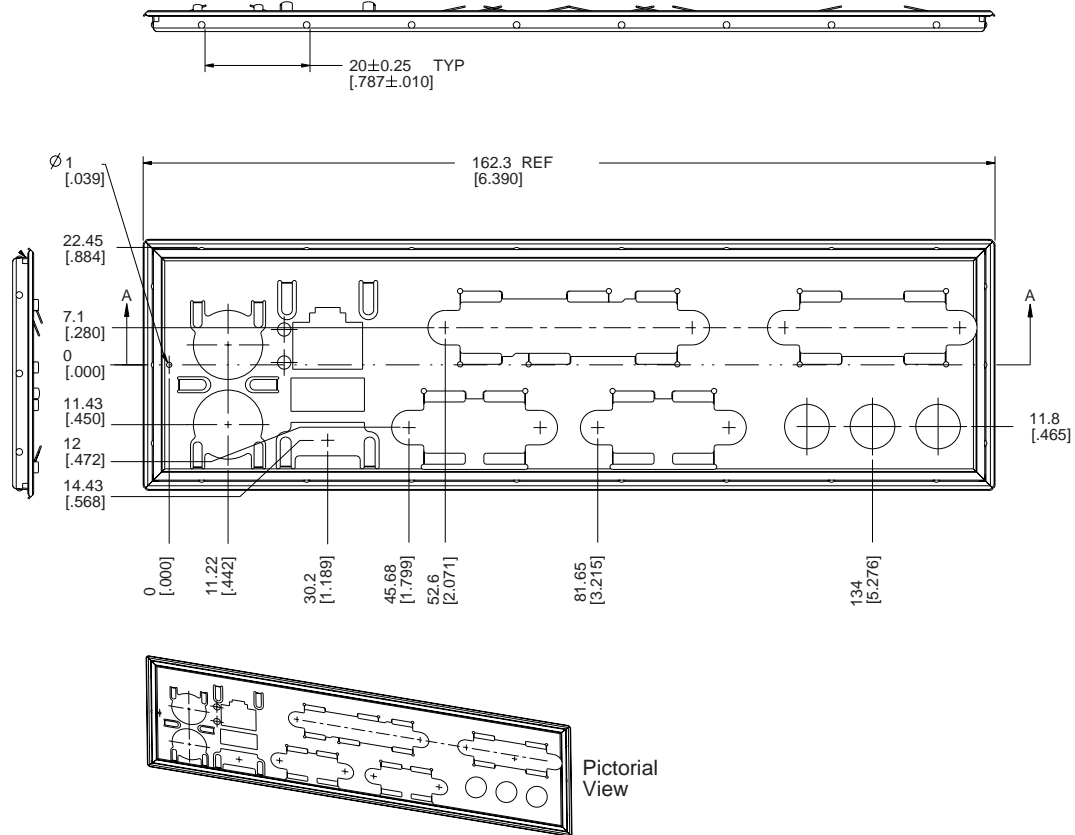

OM08374

**Figure 15. Back Panel I/O Shield Dimensions (microATX Chassis - Independent)**

## 1.20 Electrical Considerations

### 1.20.1 Power Consumption

Table 40 lists voltage and current usage for a computer that contains the motherboard, a 500 MHz Pentium® III processor, 256 MB SDRAM, 512 KB cache, 3.5-inch diskette drive, and a 2.5 GB IDE hard disk drive. This information is provided only as a guide for calculating approximate power usage with additional resources added.

Values for the Windows† 98 desktop mode are measured at 640 x 480 x 256 colors and 60 Hz refresh rate. AC watts are measured with a typical 200 W supply, nominal input voltage and frequency, with a true RMS wattmeter at the line input.

#### ⇒ NOTE

*Actual system power consumption depends upon system configuration. The power supply should comply with the recommendations found in the ATX form factor specification (see Section 6.2 for specification information).*

**Table 40. Power Usage**

| Mode   | AC (watts) | DC (amps) at: |         |         |         |         |
|--|------------|---------------|---------|---------|---------|---------|
|  |            | +3.3 V        | +5 V    | +12 V   | -12 V   | +5 V sb |
| DOS prompt, power management disabled                            | 44 W       | 1.470 A       | 3.450 A | 0.133 A | 0.039 A | 0.190 A |
| Windows 98 desktop, power management disabled                    | 45 W       | 1.483 A       | 3.360 A | 0.164 A | 0.039 A | 0.190 A |
| Windows 98 desktop, APM enabled, in System Management Mode (SMM) | 22 W       | 1.398 A       | 0.631 A | 0.128 A | 0.038 A | 0.231 A |
| Suspend to RAM (S3 state)  | 0          | 0             | 0       | 0       | 0       | 0.229 A |

## 1.20.2 Add-in Board Considerations

The motherboard is designed to provide 2 A (average) of +5 V current for each add-in board. The total +5 V current draw for add-in boards in a fully-loaded motherboard (all four expansion slots filled) must not exceed 8 A.

Table 41 lists the +5 V standby current consumed by the motherboard itself. In a system that includes PCI 2.2 compliant add-in boards that can wake the system using the PME# signal, the power supply must be capable of providing the +5 V standby current that those boards require in addition to the standby current required by the motherboard.

**Table 41. Standby Current Usage**

| Configuration                   | 5 Volt Standby Current Required |
|---------------------------------|---------------------------------|
| Motherboard with no onboard LAN | 300 mA                          |
| Motherboard with onboard LAN    | 500 mA                          |

## 1.20.3 Fan Power Requirements

Table 42 lists the maximum DC voltage and current requirements for fan 3 (the processor fan) when the board is in the Sleep mode or Normal operating mode. Power consumption is independent of the operating system used and other variables.

**Table 42. Fan 3 (Processor Fan) DC Power Requirements**

| Mode   | Voltage | Maximum Current (Amps) |
|--------|---------|------------------------|
| Sleep  | 6.7 VDC | 1 A                    |
| Normal | 9.1 VDC | 1 A                    |

## 1.20.4 Power Supply Considerations

System integrators should refer to the power usage values listed in Table 40 and Table 41 when selecting a power supply for use with this motherboard. The power supply must comply with the following recommendations found in the indicated sections of the ATX form factor specification (see Section 6.2).

- The potential relation between 3.3 VDC and +5 VDC power rails (Section 4.2)
- The current capability of the +5 VSB line (Section 4.2.2.2)
- All timing parameters (Section 4.2.2.3)
- All voltage tolerances (Section 4.2.3)

## 1.21 Thermal Considerations

Figure 16 shows the locations of the thermally sensitive components. Table 43 provides maximum component case temperatures for motherboard components that could be sensitive to thermal changes. Case temperatures could be affected by the operating temperature, current load, or operating frequency. Maximum case temperatures are important when considering proper airflow to cool the motherboard.

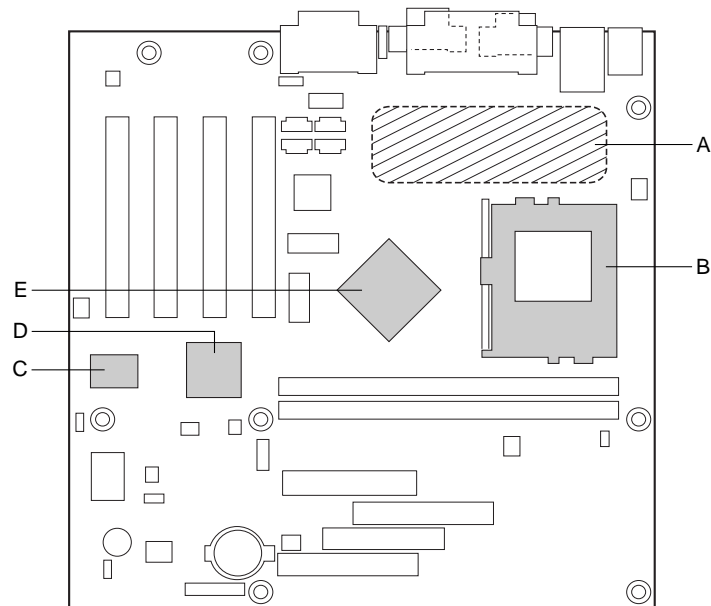

OM07768

- A Voltage regulator area
- B Intel 82810 GMCH
- C Intel Celeron processor
- D Creative Sound Blaster AudioPCI 64V audio controller
- E Intel 82801AA ICH

**Figure 16. Thermally-sensitive Components**

### ⇒ NOTE

*The voltage regulator (VREG) area can heat up to 85 °C in an open chassis. The chassis should have proper airflow.*

### ⚠ CAUTION

*An ambient temperature that exceeds the board's maximum operating temperature by 5 °C to 10 °C could cause components to exceed their maximum case temperature and malfunction. For information about the maximum operating temperature, see the environmental specifications in Section 6.2.*

**Table 43. Thermal Considerations for Components**

| Component   | Maximum Case Temperature |                       |
|---|--------------------------|-----------------------|
| Intel Celeron processor                               | 333 MHz                  | 85 °C (thermal plate) |
|   | 366 MHz                  | 85 °C (thermal plate) |
|   | 400 MHz                  | 85 °C (thermal plate) |
|   | 433 MHz                  | 85 °C (thermal plate) |
|   | 466 MHz                  | 85 °C (thermal plate) |
| Intel 82810 GMCH and optional 82810 DC-100 GMCH       | 70 °C                    |                       |
| Intel 82801AA ICH                                     | 100 °C                   |                       |
| Creative Sound Blaster Audio PCI 64V audio controller | 70 °C                    |                       |
| VREG area   | 70 °C - 85 °C            |                       |

## 1.22 Reliability

The mean time between failures (MTBF) prediction is calculated using component and subassembly random failure rates. The calculation is based on the Bellcore Reliability Prediction Procedure, TR-NWT-000332, Issue 4, September 1991. The MTBF prediction is for estimating repair rates and spare parts requirements.

The Mean Time Between Failures (MTBF) data is calculated from predicted data at 35 °C.

Motherboard MTBF: 250,920 hours

## 1.23 Environmental Specifications

**Table 44. Environmental Specifications**

| Parameter          | Specification  |                           |                                     |
|--------------------|--|---------------------------|-------------------------------------|
| <b>Temperature</b> |  |                           |                                     |
| Nonoperating       | -40 °C to +70 °C   |                           |                                     |
| Operating          | 0 °C to +55 °C   |                           |                                     |
| <b>Shock</b>       |  |                           |                                     |
| Unpackaged         | 30 g trapezoidal waveform  |                           |                                     |
|                    | Velocity change of 170 inches/sec  |                           |                                     |
| Packaged           | Half sine 2 millisecond  |                           |                                     |
|                    | <b>Product Weight (lbs)</b>  | <b>Free Fall (inches)</b> | <b>Velocity Change (inches/sec)</b> |
|                    | <20  | 36                        | 167                                 |
|                    | 21-40  | 30                        | 152                                 |
|                    | 41-80  | 24                        | 136                                 |
|                    | 81-100   | 18                        | 118                                 |
| <b>Vibration</b>   |  |                           |                                     |
| Unpackaged         | 5 Hz to 20 Hz: 0.01 g <sup>2</sup> Hz sloping up to 0.02 g <sup>2</sup> Hz         |                           |                                     |
|                    | 20 Hz to 500 Hz: 0.02 g <sup>2</sup> Hz (flat)                                     |                           |                                     |
| Packaged           | 10 Hz to 40 Hz: 0.015 g <sup>2</sup> Hz (flat)                                     |                           |                                     |
|                    | 40 Hz to 500 Hz: 0.015 g <sup>2</sup> Hz sloping down to 0.00015 g <sup>2</sup> Hz |                           |                                     |

## 1.24 Regulatory Compliance

This motherboard complies with the following safety and EMC regulations when correctly installed in a compatible host system.

### 1.24.1 Safety Regulations

Table 45 lists the safety regulations the board complies with when it is correctly installed in a compatible host system.

**Table 45. Safety Regulations**

| Regulation   | Title   |
|--|---|
| UL 1950/CSA950, 3 <sup>rd</sup> edition, Dated 07-28-95                  | Bi-National Standard for Safety of Information Technology Equipment including Electrical Business Equipment. (USA and Canada) |
| EN 60950, 2 <sup>nd</sup> Edition, 1992 (with Amendments 1, 2, 3, and 4) | The Standard for Safety of Information Technology Equipment including Electrical Business Equipment. (European Community)     |
| IEC 950, 2 <sup>nd</sup> edition, 1991 (with Amendments 1, 2, 3, and 4)  | The Standard for Safety of Information Technology Equipment including Electrical Business Equipment. (International)          |
| EMKO-TSE (74-SEC) 207/94   | Summary of Nordic deviations to EN 60950. (Norway, Sweden, Denmark, and Finland)  |

### 1.24.2 Safety Regulations

Table 46 lists the EMC regulations the board complies with when it is correctly installed in a compatible host system.

**Table 46. EMC Regulations**

| Regulation  | Title   |
|---|---|
| FCC Class B                                       | Title 47 of the Code of Federal Regulations, Parts 2 and 15, Subpart B, pertaining to unintentional radiators. (USA)                        |
| CISPR 22, 2 <sup>nd</sup> Edition, 1993 (Class B) | Limits and methods of measurement of Radio Interference Characteristics of Information Technology Equipment. (International)                |
| VCCI Class B (ITE)                                | Implementation Regulations for Voluntary Control of Radio Interference by Data Processing Equipment and Electronic Office Machines. (Japan) |
| EN55022 (1994) (Class B)                          | Limits and methods of measurement of Radio Interference Characteristics of Information Technology Equipment. (Europe)                       |
| EN50082-1 (1992)                                  | Generic Immunity Standard; Currently compliance is determined via testing to IEC 801-2, -3, and -4. (Europe)                                |
| ICES-003 (1997)                                   | Interference-Causing Equipment Standard, Digital Apparatus, Class B (Including CRC c.1374) (Canada)   |
| AS/NZ 3548  | Australian Communications Authority (ACA), Standard for Electromagnetic Compatibility   |

### 1.24.3 Certification Markings

This printed circuit assembly has the following product certification markings:

- UL Joint Recognition Mark: Consists of small c followed by a stylized backward UR and followed by a small US (Component side)
- Manufacturer's recognition mark: Consists of a unique UL recognized manufacturer's logo, along with a flammability rating (94V-0) (Solder side)
- UL File Number for motherboards: E139761 (Component side)
- PB Part Number: Intel bare circuit board part number (Solder side) 730515-004
- Battery "+ Side Up" marking: located on the component side of the board in close proximity to the battery holder
- FCC Logo/Declaration: (Solder side)
- ACA (C-Tick) mark: Consists of a unique letter C, with a tick mark; followed by N-232. Located on the component side of the motherboard and on the shipping container.
- CE Mark: (Component side) The CE mark should also be on the shipping container



## 2 Motherboard Resources

---

### What This Chapter Contains

|     |                                   |    |
|-----|-----------------------------------|----|
| 2.1 | Memory Map .....                  | 65 |
| 2.2 | DMA Channels .....                | 65 |
| 2.3 | I/O Map .....                     | 66 |
| 2.4 | PCI Configuration Space Map ..... | 68 |
| 2.5 | Interrupts .....                  | 68 |
| 2.6 | PCI Interrupt Routing Map .....   | 69 |

### 2.1 Memory Map

**Table 47. System Memory Map**

| Address Range (decimal) | Address Range (hex) | Size   | Description   |
|-------------------------|---------------------|--------|---|
| 1024 K - 524288 K       | 100000 - 1FFFFFFF   | 511 MB | Extended memory   |
| 960 K - 1024 K          | F0000 - FFFFFF      | 64 KB  | Runtime BIOS  |
| 896 K - 960 K           | E0000 - EFFFFF      | 64 KB  | Reserved  |
| 800 K - 896 K           | C8000 - DFFFFF      | 96 KB  | Available high DOS memory (open to PCI bus)             |
| 640 K - 800 K           | A0000 - C7FFF       | 160 KB | Video memory and BIOS                                   |
| 639 K - 640 K           | 9FC00 - 9FFFF       | 1 KB   | Extended BIOS data (movable by memory manager software) |
| 512 K - 639 K           | 80000 - 9FBFF       | 127 KB | Extended conventional memory                            |
| 0 K - 512 K             | 00000 - 7FFFF       | 512 KB | Conventional memory                                     |

### 2.2 DMA Channels

**Table 48. DMA Channels**

| DMA Channel Number | Data Width    | System Resource                      |
|--------------------|---------------|--------------------------------------|
| 0                  | 8- or 16-bits | Audio                                |
| 1                  | 8- or 16-bits | Audio / parallel port                |
| 2                  | 8- or 16-bits | Diskette drive                       |
| 3                  | 8- or 16-bits | Parallel port (for ECP or EPP)/audio |
| 4                  |               | DMA controller                       |
| 5                  | 16-bits       | Open                                 |
| 6                  | 16-bits       | Open                                 |
| 7                  | 16-bits       | Open                                 |

## 2.3 I/O Map

**Table 49. I/O Map**

| Address (hex)  | Size                               | Description   |
|--|------------------------------------|---|
| 0000 - 000F  | 16 bytes                           | DMA controller  |
| 0020 - 0021  | 2 bytes                            | Programmable Interrupt Control (PIC)                      |
| 0040 - 0043  | 4 bytes                            | System timer  |
| 0060   | 1 byte                             | Keyboard controller byte—reset IRQ                        |
| 0061   | 1 byte                             | System speaker  |
| 0064   | 1 byte                             | Keyboard controller, CMD/STAT byte                        |
| 0070 - 0071  | 2 bytes                            | System CMOS/Real Time Clock                               |
| 0072 - 0073  | 2 bytes                            | System CMOS   |
| 0080 - 008F  | 16 bytes                           | DMA controller  |
| 0092   | 1 byte                             | Fast A20 and PIC  |
| 00A0 - 00A1  | 2 bytes                            | PIC   |
| 00B2 - 00B3  | 2 bytes                            | APM control   |
| 00C0 - 00DF  | 32 bytes                           | DMA   |
| 00F0   | 1 byte                             | Numeric data processor                                    |
| 0170 - 0177  | 8 bytes                            | Secondary IDE channel                                     |
| 01F0 - 01F7  | 8 bytes                            | Primary IDE channel                                       |
| One of these ranges:<br>0200 - 0207<br>0208 - 020F<br>0210 - 0217<br>0218 - 021F | Can vary from 1 byte<br>to 8 bytes | Audio/game port   |
| One of these ranges:<br>0220 - 022F<br>0240 - 024F                               | 16 bytes<br>16 bytes               | Audio (Sound Blaster Pro <sup>†</sup> -compatible)        |
| 0228 - 022F*   | 8 bytes                            | LPT3  |
| 0278 - 027F*   | 8 bytes                            | LPT2  |
| 02E8 - 02EF*   | 8 bytes                            | COM4/video (8514A)  |
| 02F8 - 02FF*   | 8 bytes                            | COM2  |
| One of these ranges:<br>0320 - 0327<br>0330 - 0337<br>0340 - 0347<br>0350 - 0357 | 8 bytes                            | MPU-401 (MIDI)  |
| 0376   | 1 byte                             | Secondary IDE channel command port                        |
| 0377, bits 6:0   | 7 bits                             | Secondary IDE channel status port                         |
| 0378 - 037F  | 8 bytes                            | LPT1  |
| 0388- 038B   | 6 bytes                            | AdLib <sup>†</sup> (FM synthesizer)                       |
| 03B0 - 03BB  | 12 bytes                           | Intel 82810 - DC100 Graphics/Memory Controller Hub (GMCH) |
| 03C0 - 03DF  | 32 bytes                           | Intel 82810 Graphics/Memory Controller Hub (GMCH)         |
| 03E8 - 03EF  | 8 bytes                            | COM3  |

continued

**Table 49. I/O Map** (continued)

| Address (hex)   | Size    | Description                        |
|---|---------|------------------------------------|
| 03F0 - 03F5   | 6 bytes | Diskette channel 1                 |
| 03F6  | 1 byte  | Primary IDE channel command port   |
| 03F8 - 03FF   | 8 bytes | COM1                               |
| 04D0 - 04D1   | 2 bytes | Edge/level triggered PIC           |
| One of these ranges:<br>0530 - 0537<br>0E80 - 0E87<br>0F40 - 0F47 | 8 bytes | Windows Sound System               |
| LPTn + 400h   | 8 bytes | ECP port, LPTn base address + 400h |
| 0CF8 - 0CFB**   | 4 bytes | PCI configuration address register |
| 0CF9***   | 1 byte  | Turbo and reset control register   |
| 0CFC - 0CFF   | 4 bytes | PCI configuration data register    |
| FFA0 - FFA7   | 8 bytes | Primary bus master IDE registers   |
| FFA8 - FFAF   | 8 bytes | Secondary bus master IDE registers |
| 96 contiguous bytes starting on a 128-byte divisible boundary     |         | ICH (ACPI + TCO)                   |
| 64 contiguous bytes starting on a 64-byte divisible boundary      |         | Motherboard resource               |
| 64 contiguous bytes starting on a 64-byte divisible boundary      |         | Onboard audio controller           |
| 32 contiguous bytes starting on a 32-byte divisible boundary      |         | ICH (USB)                          |
| 16 contiguous bytes starting on a 16-byte divisible boundary      |         | ICH (SMB)                          |
| 4096 contiguous bytes starting on a 4096-byte divisible boundary  |         | Intel 82810AA PCI bridge           |
| 32 contiguous bytes starting on a 32-byte divisible boundary      |         | Intel 82559 LAN controller         |

\* Default, but can be changed to another address range.

\*\* Dword access only

\*\*\* Byte access only

## ⇒ NOTE

*Some additional I/O addresses are not available due to ICH addresses aliasing. For information about the ICH addressing, refer to the Intel web site at:*

<http://developer.intel.com/design/chipsets/datashts/>

## 2.4 PCI Configuration Space Map

**Table 50. PCI Configuration Space Map**

| Bus Number (hex) | Device Number (hex) | Function Number (hex) | Description  |
|------------------|---------------------|-----------------------|--|
| 00               | 00                  | 00                    | Intel 82810 Graphics/Memory Controller Hub (GMCH)        |
| 00               | 01                  | 00                    | Intel 82810 Graphics/Memory Controller Hub (GMCH)        |
| 00               | 1E                  | 00                    | Hub link to PCI bridge                                   |
| 00               | 1F                  | 00                    | Intel 82801AA I/O Controller Hub (ICH) PCI to LPC bridge |
| 00               | 1F                  | 01                    | IDE  |
| 00               | 1F                  | 02                    | USB  |
| 00               | 1F                  | 03                    | SMBUS  |
| 00               | 1F                  | 05                    | AC '97 audio controller or reserved                      |
| 00               | 1F                  | 06                    | AC '97 modem controller or reserved                      |
| 01               | 01                  | 00                    | Intel 82559 LAN controller (optional)                    |
| 01               | 07                  | 00                    | Creative Sound Blaster AudioPCI 64V                      |
| 01               | 08                  | 00                    | PCI expansion slot 1 (J4C1)                              |
| 01               | 09                  | 00                    | PCI expansion slot 2 (J4B1)                              |
| 01               | 0A                  | 00                    | PCI expansion slot 3 (J4A2)                              |
| 01               | 0B                  | 00                    | PCI expansion slot 4 (J4A1)                              |

## 2.5 Interrupts

**Table 51. Interrupts**

| IRQ | System Resource                                      |
|-----|--|
| NMI | I/O channel check                                    |
| 0   | Reserved, interval timer                             |
| 1   | Reserved, keyboard buffer full                       |
| 2   | Reserved, cascade interrupt from slave PIC           |
| 3   | COM2* (user available if COM2 is not present)        |
| 4   | COM1*  |
| 5   | LPT2 (Plug and Play option)/audio/user available     |
| 6   | Diskette drive controller                            |
| 7   | LPT1*  |
| 8   | Real time clock                                      |
| 9   | User available                                       |
| 10  | User available                                       |
| 11  | User available                                       |
| 12  | Onboard mouse port (if present, else user available) |
| 13  | Reserved, math coprocessor                           |
| 14  | Primary IDE (if present, else user available)        |
| 15  | Secondary IDE (if present, else user available)      |

\* Default, but can be changed to another IRQ

## 2.6 PCI Interrupt Routing Map

This section describes interrupt sharing and how the interrupt signals are connected between the PCI expansion slots and onboard PCI devices. The PCI specification specifies how interrupts can be shared between devices attached to the PCI bus. In most cases, the small amount of latency added by interrupt sharing does not affect the operation or throughput of the devices. In some special cases where maximum performance is needed from a device, a PCI device should not share an interrupt with other PCI devices. Use the following information to avoid sharing an interrupt with a PCI add-in card.

PCI devices are categorized as follows to specify their interrupt grouping:

- **INTA:** By default, all add-in cards that require only one interrupt are in this category. For almost all cards that require more than one interrupt, the first interrupt on the card is also classified as INTA.
- **INTB:** Generally, the second interrupt on add-in cards that require two or more interrupts is classified as INTB. (This is not an absolute requirement.)
- **INTC and INTD:** Generally, a third interrupt on add-in cards is classified as INTC and a fourth interrupt is classified as INTD.

The ICH has four programmable interrupt request (PIRQ) input signals. Any PCI interrupt source (either onboard or from a PCI add-in card) connects to one of these PIRQ signals. Because there are only four signals, some PCI interrupt sources are mechanically tied together on the motherboard and therefore share the same interrupt. Table 52 shows an example of how the PIRQ signals might be connected to a riser card's PCI expansion slots and to onboard PCI interrupt sources.

**Table 52. PCI Interrupt Routing Map**

| ICH PIRQ Signal | First PCI Expansion Slot (J4C1) | Second PCI Expansion Slot (J4B1) | Third PCI Expansion Slot (J4A2) | Fourth PCI Expansion Slot (J4A1) | AGP  | USB  | SMB  | PCI Audio | LAN Controller |
|-----------------|---------------------------------|----------------------------------|---------------------------------|----------------------------------|------|------|------|-----------|----------------|
| PIRQA           | INTA                            | INTD                             | INTC                            | INTB                             | INTA |      |      |           |                |
| PIRQB           | INTB                            | INTA                             | INTD                            | INTC                             |      |      | INTB |           |                |
| PIRQC           | INTC                            | INTB                             | INTA                            | INTD                             |      |      |      | INTA      |                |
| PIRQD           | INTD                            | INTC                             | INTB                            | INTA                             |      | INTD |      |           | INTA           |

Using the example shown in Table 52, assume an add-in card with one interrupt (group INTA) is inserted into the fourth PCI slot. In this slot, an interrupt source from group INTA connects to the PIRQD signal, which is already connected to the LAN and USB PCI sources. The add-in card shares an interrupt with these onboard interrupt sources.



# 3 Overview of BIOS Features

---

## What This Chapter Contains

|     |                                       |    |
|-----|---------------------------------------|----|
| 3.1 | Introduction.....                     | 71 |
| 3.2 | BIOS Flash Memory Organization .....  | 72 |
| 3.3 | Resource Configuration .....          | 72 |
| 3.4 | System Management BIOS (SMBIOS) ..... | 73 |
| 3.5 | BIOS Upgrades .....                   | 74 |
| 3.6 | Recovering BIOS Data .....            | 74 |
| 3.7 | Boot Options.....                     | 75 |
| 3.8 | USB Legacy Support .....              | 76 |
| 3.9 | BIOS Security Features.....           | 77 |

## 3.1 Introduction

The motherboard uses an Intel/AMI BIOS, which is stored in flash memory and can be upgraded using a disk-based program. The flash memory also contains the Setup program, POST, APM, ACPI, PCI autoconfiguration utility, and Windows 98-ready Plug and Play. See Section 6.2 for the supported versions of APM and ACPI.

This motherboard supports system BIOS shadowing, allowing the BIOS to execute from 64-bit onboard write-protected DRAM.

The BIOS displays a message during POST identifying the type of BIOS and a revision code. The initial production BIOS is identified as 8C1A100A.86A. For BIOS Setup screen information for motherboards with BIOS identifier 8C1A100A.86R, refer to Section 4.1 on page 79.

## 3.2 BIOS Flash Memory Organization

The Intel 82802AB Firmware Hub (FWH) is a high performance 4 Mbit (512 KB) symmetrical flash memory device. Internally, the device is grouped into eight 64-KB blocks that are individually erasable, lockable, and unlockable. Figure 17 shows the organization of the flash memory.

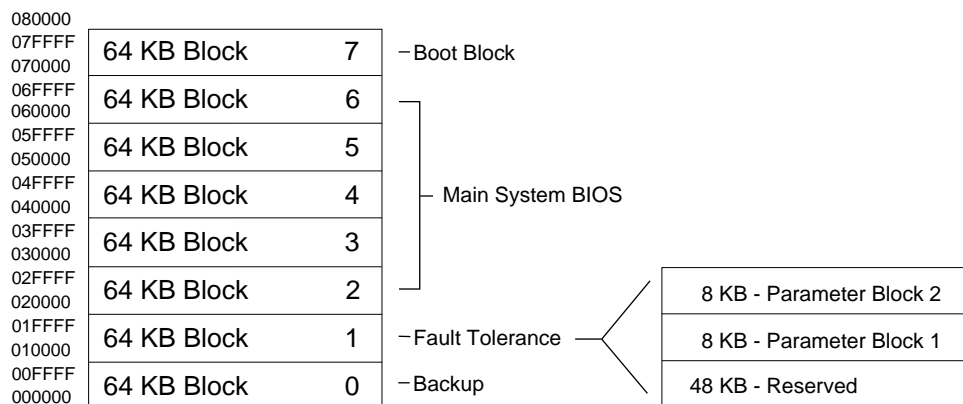

OM08376

**Figure 17. Memory Map of the Flash Memory Device**

Symmetrical flash memory allows both the boot and the fault tolerance blocks to increase in size from 16 KB to 64 KB. This increase allows the addition of features such as dynamic memory detection, LS-120 recovery code, and extended security features.

The last two 8 KB blocks of the fault tolerance area are the parameter blocks. These blocks contain data such as BIOS updates, vital product data (VPD), logo, System Management BIOS (SMBIOS) interface, and extended system configuration data (ESCD) information. The backup block contains a copy of the fault tolerance block.

## 3.3 Resource Configuration

### 3.3.1 PCI Autoconfiguration

The BIOS can automatically configure PCI devices. PCI devices may be onboard or add-in cards. Autoconfiguration lets a user insert or remove PCI or Plug and Play cards without having to configure the system. When a user turns on the system after adding a PCI card, the BIOS automatically configures interrupts, the I/O space, and other system resources. Any interrupts set to Available in Setup are considered to be available for use by the add-in card.

For information about the versions of PCI supported by this BIOS, see Section 6.2.

### 3.3.2 PCI IDE Support

If the user selects Auto in Setup (see Section 4.4.4), the BIOS automatically sets up the two PCI IDE connectors with independent I/O channel support. The IDE interface supports hard drives up to PIO Mode 4 and recognizes any ATAPI devices, including CD-ROM drives, tape drives, and Ultra DMA drives (see Section 6.2 for the supported version of ATAPI). Add-in ISA IDE controllers are not supported. The BIOS determines the capabilities of each drive and configures it to optimize capacity and performance. You can override the autoconfiguration option by specifying User configuration in the IDE configuration Submenu of the BIOS Setup program.

To use the ATA-66 functionality, the following items are required:

- An ATA-66 peripheral device
- An ATA-66 compatible cable
- ATA-66 operating system device drivers

#### ⇒ NOTE

*ATA-66 compatible cables are backward compatible with drives using slower IDE transfer protocols. If an Ultra ATA/66 drive and a drive using any other IDE transfer protocol are attached to the same cable, the maximum transfer rate for either drive is 33 MB/second.*

#### ⇒ NOTE

*Do not connect an ATA device as a slave on the same IDE cable as an ATAPI master device.*

## 3.4 System Management BIOS (SMBIOS)

SMBIOS is an interface for managing computers in an enterprise environment. The main component of SMBIOS is the management information format (MIF) database, which contains information about the computing system and its components. Using SMBIOS, a system administrator can obtain the system types, capabilities, operational status, and installation dates for system components. The MIF database defines the data and provides the method for accessing this information. The BIOS enables applications such as Intel® LANDesk® Client Manager to use SMBIOS. The BIOS stores and reports the following SMBIOS information:

- BIOS data, such as the BIOS revision level
- Fixed-system data, such as peripherals, serial numbers, and asset tags
- Resource data, such as memory size, cache size, and processor speed
- Dynamic data, such as event detection and error logging

Non-Plug and Play operating systems, such as Windows NT, require an additional interface for obtaining SMBIOS information. The BIOS supports an SMBIOS table interface for such operating systems. Using this support, a SMBIOS service-level application running on a non-Plug and Play operating system can access the SMBIOS BIOS information.

See Section 6.2 for SMBIOS specification information.

## 3.5 BIOS Upgrades

A new version of the BIOS can be upgraded from a diskette using the Intel® Flash Memory Update Utility that is available from Intel. This utility supports the following BIOS maintenance functions:

- Update the flash BIOS from a file on a diskette
- Verify that the upgrade BIOS matches the target system to prevent accidentally installing an incompatible BIOS
- BIOS boot block update

BIOS upgrades and the Intel Flash Memory Update Utility are available from Intel through the Intel World Wide Web site. See Section 0 for information about this site.

### ⇒ NOTE

*Please review the instructions distributed with the upgrade utility before attempting a BIOS upgrade.*

### 3.5.1 Language Support

The Setup program and help messages can be supported in 32 languages. Five languages are available in the BIOS: American English, German, Italian, French, and Spanish. The default language is American English, which is present unless another language is selected in BIOS Setup.

The BIOS includes extensions to support the Kanji character set and other non-ASCII character sets. Translations of other languages may become available at a later date.

### 3.5.2 Custom Splash Screen

During POST, an Intel splash screen is displayed by default. This splash screen can be replaced with a custom splash screen. A utility is available from Intel to assist with creating a custom splash screen. The custom splash screen can be programmed into the flash memory using the BIOS upgrade utility. Information about this capability is available on the Intel Support world wide web site. See Section 6.1 for more information about this site.

## 3.6 Recovering BIOS Data

Some types of failure can destroy the BIOS. For example, the data can be lost if a power outage occurs while the BIOS is being updated in flash memory. To recover the BIOS from a diskette, the user must set the BIOS Setup configuration jumper block to recovery mode (see page 54). When recovering the BIOS, the user must be aware of the following:

- Because of the small amount of code available in the nonerasable boot block area, there is no video support. The procedure can be monitored only by listening to the speaker and looking at the diskette drive LED.
- The recovery process may take several minutes; larger BIOS flash memory devices require more time.

- Two beeps and the end of activity in the diskette drive indicate successful BIOS recovery.
- A series of continuous beeps indicates a failed BIOS recovery.

To create a BIOS recovery diskette, a bootable diskette must be created and the recovery files copied to it. The recovery files are available from Intel. See Section 0 for information on contacting Intel customer support for more information.

⇒ **NOTE**

*If the computer is configured to recover the BIOS from an diskette in an LS-120 drive (see Sections 1.7 and 4.7), the BIOS recovery diskette must be a standard 1.44 MB diskette, not a 120 MB diskette.*

## 3.7 Boot Options

In the Setup program, the user can choose to boot from a diskette drive, hard drives, CD-ROM, or the network. The default setting is for the diskette drive to be the primary boot device and the hard drive to be the secondary boot device. By default the third and fourth devices are disabled.

### 3.7.1 CD-ROM and Network Boot

Booting from CD-ROM is supported in compliance with the El Torito bootable CD-ROM format specification. See Section 6.2 for information about the El Torito specification. Under the Boot menu in the Setup program, ATAPI CD-ROM is listed as a boot device. Boot devices are defined in priority order. If the CD-ROM is selected as the boot device, it must be the first device.

The network can be selected as a boot device. This selection allows booting from a network add-in card with a remote boot ROM installed.

### 3.7.2 Booting Without Attached Devices

For use in embedded applications, the BIOS has been designed so that after passing the POST, the operating system loader is invoked even if no video adapter, keyboard, or mouse is attached.

### 3.7.3 Default Settings After Battery and Power Failure

If the battery and AC power fail, standard defaults, not custom defaults, will be loaded into CMOS RAM at power on.

## 3.8 USB Legacy Support

USB legacy support enables a USB keyboard or mouse to be used when no operating system USB driver is in place. USB legacy support is intended to be used only in accessing BIOS Setup and installing an operating system that supports USB.

To install an operating system that supports USB, set USB legacy support in BIOS Setup to Auto, and follow the operating system's installation instructions. This sequence describes how USB legacy support operates in the default (Auto) mode.

1. When the user powers up the computer, USB legacy support is set to Auto in Setup.
2. The POST begins.
3. If the POST detects a USB keyboard, the BIOS enables the keyboard to be used to enter the Setup program or maintenance mode.
4. After the operating system loads, the USB keyboard and mouse will be usable and controlled by the BIOS until a USB driver takes control.

### ⇒ NOTES

*If USB legacy support is enabled, do not mix USB and PS/2 keyboards and mice. For example, do not use a PS/2 keyboard with a USB mouse, or a USB keyboard and a PS/2 mouse.*

*Do not use USB devices with an operating system that does not support USB. USB legacy is not intended to support the use of USB devices in a non-USB aware operating system.*

*USB legacy support is for keyboards and mice only. Hubs and other USB devices are not supported.*

## 3.9 BIOS Security Features

The BIOS includes security features that restrict access to the BIOS Setup program and restrict who can boot the computer. A supervisor password and a user password can be set for accessing the Setup program and for booting the computer, with the following restrictions:

- The supervisor password gives unrestricted access to view and change all the Setup options in the Setup program. This is supervisor mode.
- The user password gives restricted access to view and change Setup options in the Setup program. This is user mode.
- If only the supervisor password is set, pressing the <Enter> key at the password prompt of the Setup program allows the user restricted access to Setup.
- If both the supervisor and user passwords are set, users can enter either the supervisor password or the user password to access Setup. Users have access to Setup respective to which password is entered.
- Setting the user password restricts who can boot the computer. The password prompt will be displayed before the computer is booted. If only the supervisor password is set, the computer boots without asking for a password. If both passwords are set, the user can enter either password to boot the computer.

Table 53 shows the effects of setting the supervisor password and user password. This table is for reference only and is not displayed on the screen.

**Table 53. Supervisor and User Password Functions**

| Password Set            | Supervisor Mode          | User Mode                              | Setup Options                         | Password to Enter Setup | Password During Boot |
|-------------------------|--------------------------|--|---------------------------------------|-------------------------|----------------------|
| Neither                 | Can change all options * | Can change all options *               | None                                  | None                    | None                 |
| Supervisor only         | Can change all options   | Can change a limited number of options | Supervisor Password                   | Supervisor              | None                 |
| User only               | N/A                      | Can change all options                 | Enter Password<br>Clear User Password | User                    | User                 |
| Supervisor and user set | Can change all options   | Can change a limited number of options | Supervisor Password<br>Enter Password | Supervisor or user      | Supervisor or user   |

\* If no password is set, any user can change all Setup options.

See Section 4.5 for information about setting user and supervisor passwords.



# 4 BIOS Setup Program

---

## What This Chapter Contains

|     |                        |    |
|-----|------------------------|----|
| 4.1 | Introduction.....      | 79 |
| 4.2 | Maintenance Menu ..... | 80 |
| 4.3 | Main Menu.....         | 80 |
| 4.4 | Advanced Menu.....     | 81 |
| 4.5 | Security Menu.....     | 86 |
| 4.6 | Power Menu .....       | 86 |
| 4.7 | Boot Menu .....        | 87 |
| 4.8 | Exit Menu .....        | 88 |

### 4.1 Introduction

The Setup program is used for viewing and changing the BIOS settings for a computer. The user accesses Setup by pressing the <F2> key after the Power-On Self Test (POST) memory test begins and before the operating system boot begins.

Some motherboards are manufactured with a BIOS having an identifier of 8C1A100A.86R. For information on the BIOS Setup program menus for those boards, refer to the *CA810 Motherboard Product Guide*, available through the Intel World Wide Web Site. See Section 6.1 for information about this site.

The BIOS Setup program menus described in this chapter apply only to standard CA810 motherboards with a BIOS identifier 8C1A100A.86A.

Table 54 shows the menus available from the menu bar at the top of the Setup screen.

**Table 54. Setup Menu Bar**

| Setup Menu Screen | Description  |
|-------------------|--|
| Maintenance       | Clears the Setup passwords. This menu is available only in configure mode. Refer to Section 1.18 for information about configure mode. |
| Main              | Allocates resources for hardware components.   |
| Advanced          | Specifies advanced features available through the chipset.   |
| Security          | Specifies passwords and security features.   |
| Power             | Specifies power management features.   |
| Boot              | Specifies boot options and power supply controls.  |
| Exit              | Saves or discards changes to the Setup program options.  |

Table 55 shows the function keys available for menu screens.

**Table 55. Setup Function Keys**

| Setup Key  | Description  |
|------------|--|
| <←> or <→> | Selects a different menu screen.                             |
| <↑> or <↓> | Moves cursor up or down.                                     |
| <Tab>      | Selects a field.   |
| <Enter>    | Executes command or selects the submenu.                     |
| <F9>       | Loads the default configuration values for the current menu. |
| <F10>      | Saves the current values and exits Setup.                    |
| <Esc>      | Exits the menu.  |

## 4.2 Maintenance Menu

Setup displays this menu only in configure mode. See Section 1.18 for information about setting configure mode.

**Table 56. Maintenance Menu**

| Feature             | Options    | Description                               |
|---------------------|------------|---|
| Clear All Passwords | No options | Clears the user and supervisor passwords. |

## 4.3 Main Menu

This menu reports processor and memory information. This menu is used to set the system date and system time.

**Table 57. Main Menu**

| Feature          | Options                  | Description  |
|------------------|--------------------------|--|
| BIOS Version     | No options               | Displays the version of the BIOS.                        |
| Processor Type   | No options               | Displays processor type.                                 |
| Processor Speed  | No options               | Displays processor speed.                                |
| Cache RAM        | No options               | Displays the size of second-level cache.                 |
| Total Memory     | No options               | Displays the total amount of RAM on the motherboard.     |
| Bank 0<br>Bank 1 | No options               | Displays the type of DIMM installed in each memory bank. |
| System Time      | Hour, minute, and second | Specifies the current time.                              |
| System Date      | Month, day, and year     | Specifies the current date.                              |

## 4.4 Advanced Menu

This menu is used for setting advanced features that are available through the chipset.

**Table 58. Advanced Menu**

| Feature                     | Options    | Description   |
|-----------------------------|------------|---|
| Boot Settings Configuration | No options | Configures Plug and Play and the Numlock key, and resets configuration data. When selected, displays the Boot Settings Configuration submenu. |
| Peripheral Configuration    | No options | Configures peripheral ports and devices. When selected, displays the Peripheral Configuration submenu.  |
| IDE Configuration           | No options | Specifies type of connected IDE device.   |
| Diskette Configuration      | No options | When selected, displays the Diskette Configuration submenu.   |
| Event Log Configuration     | No options | Configures Event Logging. When selected, displays the Event Log Configuration submenu.  |

### 4.4.1 Boot Setting Configuration Submenu

This menu is used for setting Plug and Play and the Numlock key, and for resetting configuration data.

**Table 59. Boot Setting Configuration Submenu**

| Feature           | Options                    | Description   |
|-------------------|----------------------------|---|
| Plug & Play O/S   | <b>No (default)</b><br>Yes | Specifies if a Plug and Play operating system is being used.<br><i>No</i> lets the BIOS configure all devices.<br><i>Yes</i> lets the operating system configure Plug and Play devices. Not required with a Plug and Play operating system. |
| Reset Config Data | <b>No (default)</b><br>Yes | Clears the BIOS configuration data on the next boot.  |
| NumLock           | Off<br><b>On (default)</b> | Specifies the power on state of the Numlock feature on the numeric keypad of the keyboard.  |

## 4.4.2 Peripheral Configuration Submenu

This submenu is used for configuring the computer peripherals.

**Table 60. Peripheral Configuration Submenu**

| Feature          | Options   | Description   |
|------------------|---|---|
| Serial port A    | <ul style="list-style-type: none"> <li>• Disabled</li> <li>• Enabled</li> <li>• <b>Auto (default)</b></li> </ul>                        | Configures serial port A.<br><i>Auto</i> assigns the first free COM port, normally COM1, the address 3F8h, and the interrupt IRQ4.  |
| Base I/O address | <ul style="list-style-type: none"> <li>• <b>3F8 (default)</b></li> <li>• 2F8</li> <li>• 3E8</li> <li>• 2E8</li> </ul>                   | Specifies the base I/O address for serial port A, if serial port A is Enabled.  |
| Interrupt        | <ul style="list-style-type: none"> <li>• IRQ 3</li> <li>• <b>IRQ 4 (default)</b></li> </ul>   | Specifies the interrupt for serial port A, if serial port A is Enabled.   |
| Serial port B    | <ul style="list-style-type: none"> <li>• Disabled</li> <li>• Enabled</li> <li>• <b>Auto (default)</b></li> </ul>                        | Configures serial port B.   |
| Mode             | <ul style="list-style-type: none"> <li>• <b>Normal (default)</b></li> <li>• IrDA SIR-A</li> <li>• ASK-IR</li> </ul>                     | Specifies the mode for serial port B for normal (COM2) or infrared applications. This option is not available if serial port B has been disabled.   |
| Base I/O address | <ul style="list-style-type: none"> <li>• <b>2F8 (default)</b></li> <li>• 3E8</li> <li>• 2E8</li> </ul>                                  | Specifies the base I/O address for serial port B.   |
| Interrupt        | <ul style="list-style-type: none"> <li>• <b>IRQ3 (default)</b></li> <li>• IRQ4</li> </ul>   | Specifies the interrupt for serial port B.  |
| Parallel port    | <ul style="list-style-type: none"> <li>• Disabled</li> <li>• Enabled</li> <li>• <b>Auto (default)</b></li> </ul>                        | Configures the parallel port.<br><i>Auto</i> assigns LPT1 the address 378h and the interrupt IRQ7.<br>An * (asterisk) displayed next to an address indicates a conflict with another device.  |
| Mode             | <ul style="list-style-type: none"> <li>• Output Only</li> <li>• <b>Bidirectional (default)</b></li> <li>• EPP</li> <li>• ECP</li> </ul> | Selects the mode for the parallel port. Not available if the parallel port is disabled.<br><i>Output Only</i> operates in AT <sup>†</sup> -compatible mode.<br><i>Bidirectional</i> operates in PS/2-compatible mode.<br><i>EPP</i> is Extended Parallel Port mode, a high-speed bidirectional mode.<br><i>ECP</i> is Enhanced Capabilities Port mode, a high-speed bidirectional mode. |

continued

**Table 60. Peripheral Configuration Submenu** (continued)

| Feature            | Options   | Description   |
|--------------------|---|---|
| Base I/O address   | <ul style="list-style-type: none"> <li>• <b>378 (default)</b></li> <li>• 278</li> <li>• 228</li> </ul>            | Specifies the base I/O address for the parallel port.                           |
| Interrupt          | <ul style="list-style-type: none"> <li>• <b>IRQ 5 (default)</b></li> <li>• IRQ 7</li> </ul>                       | Specifies the interrupt for the parallel port.                                  |
| Legacy USB Support | <ul style="list-style-type: none"> <li>• Disabled</li> <li>• Keyboard</li> <li>• <b>Auto (default)</b></li> </ul> | Enables or disables USB legacy support. (See Section 3.8 for more information.) |
| Audio Device       | <ul style="list-style-type: none"> <li>• <b>Enabled (default)</b></li> <li>• Disabled</li> </ul>                  | Configures the audio device.  |
| LAN                | <ul style="list-style-type: none"> <li>• <b>Enabled (default)</b></li> <li>• Disabled</li> </ul>                  | Configures the optional LAN device.   |

### 4.4.3 IDE Configuration

**Table 61. IDE Device Configuration**

| Feature              | Options  | Description  |
|----------------------|--|--|
| IDE Controller       | <ul style="list-style-type: none"> <li>• Disabled</li> <li>• Primary</li> <li>• Secondary</li> <li>• <b>Both (default)</b></li> </ul>  | Specifies the integrated IDE controller. <i>Primary</i> enables only the primary IDE controller. <i>Secondary</i> enables only the secondary IDE controller. <i>Both</i> enables both IDE controllers. |
| Hard Disk Pre-Delay  | <ul style="list-style-type: none"> <li>• <b>Disabled (default)</b></li> <li>• 3 Seconds</li> <li>• 6 Seconds</li> <li>• 9 Seconds</li> <li>• 12 Seconds</li> <li>• 15 Seconds</li> <li>• 21 Seconds</li> <li>• 30 Seconds</li> </ul> | Specifies the hard disk drive predelay.  |
| Primary IDE Master   | No options   | Reports type of connected IDE device. When selected, displays the Primary IDE Master submenu.  |
| Primary IDE Slave    | No options   | Reports type of connected IDE device. When selected, displays the Primary IDE Slave submenu.   |
| Secondary IDE Master | No options   | Reports type of connected IDE device. When selected, displays the Secondary IDE Master submenu.  |
| Secondary IDE Slave  | No options   | Reports type of connected IDE device. When selected, displays the Secondary IDE Slave submenu.   |

#### 4.4.4 IDE Configuration Submenus

There is a submenu for configuring each of the following IDE devices:

- Primary IDE master
- Primary IDE slave
- Secondary IDE master
- Secondary IDE slave

**Table 62. IDE Configuration Submenus**

| Feature                | Options  | Description   |
|------------------------|--|---|
| Type                   | <ul style="list-style-type: none"> <li>• None</li> <li>• User</li> <li>• <b>Auto (default)</b></li> <li>• CD-ROM</li> <li>• ATAPI Removable</li> <li>• Other ATAPI</li> <li>• IDE Removable</li> </ul> | <p>Specifies the IDE configuration mode for IDE devices.</p> <p><i>User</i> allows the cylinders, heads, and sectors fields to be changed.</p> <p><i>Auto</i> automatically fills in the values for the cylinders, heads, and sectors fields.</p> |
| Maximum Capacity       | No options   | Reports the maximum capacity for the hard disk, if the type is User or Auto.  |
| LBA Mode Control       | <ul style="list-style-type: none"> <li>• Disabled</li> <li>• <b>Enabled (default)</b></li> </ul>   | Enables or disables the LBA mode control.   |
| Multi-Sector Transfers | <ul style="list-style-type: none"> <li>• Disabled</li> <li>• 2 Sectors</li> <li>• 4 Sectors</li> <li>• 8 Sectors</li> <li>• <b>16 Sectors (default)</b></li> </ul>                                     | <p>Specifies number of sectors per block for transfers from the hard disk drive to memory.</p> <p>Check the hard disk drive's specifications for optimum setting.</p>   |
| PIO Mode               | <ul style="list-style-type: none"> <li>• <b>Auto (default)</b></li> <li>• 0</li> <li>• 1</li> <li>• 2</li> <li>• 3</li> <li>• 4</li> </ul>   | Specifies the method for moving data to/from the drive.   |
| Ultra DMA              | <ul style="list-style-type: none"> <li>• <b>Disabled (default)</b></li> <li>• Mode 0</li> <li>• Mode 1</li> <li>• Mode 2</li> <li>• Mode 3</li> </ul>  | Specifies the Ultra DMA mode for the drive.   |

### 4.4.5 Diskette Configuration Submenu

This submenu is used for configuring the diskette drive.

**Table 63. Diskette Configuration Submenu**

| Feature                | Options  | Description   |
|------------------------|--|---|
| Diskette Controller    | <ul style="list-style-type: none"> <li>Disabled</li> <li><b>Enabled (default)</b></li> </ul>   | Disables or enables the integrated diskette controller.       |
| Floppy A:              | <ul style="list-style-type: none"> <li>Not Installed</li> <li>360 KB 5¼</li> <li>1.2 MB 5¼</li> <li>720 KB 3½</li> <li><b>1.44/1.25 MB 3½ (default)</b></li> <li>2.88 MB 3½</li> </ul> | Specifies the capacity and physical size of diskette drive A. |
| Diskette Write Protect | <ul style="list-style-type: none"> <li><b>Disabled (default)</b></li> <li>Enabled</li> </ul>   | Disables or enables write protect for the diskette drive.     |

### 4.4.6 Event Log Configuration

This submenu is used for configuring the event logging features.

**Table 64. Event Log Configuration Submenu**

| Feature              | Options  | Description   |
|----------------------|--|---|
| Event Log            | No options   | Indicates if there is space available in the event log. |
| Event Log Validity   | No options   | Indicates if the contents of the event log are valid.   |
| View Event Log       | [Enter]  | Displays the event log.                                 |
| Clear All Event Logs | <ul style="list-style-type: none"> <li><b>No (default)</b></li> <li>Yes</li> </ul>           | Clears the event log after rebooting.                   |
| Event Logging        | <ul style="list-style-type: none"> <li>Disabled</li> <li><b>Enabled (default)</b></li> </ul> | Enables logging of events.                              |
| Mark Events As Read  | [Enter]  | Marks all events as read.                               |

## 4.5 Security Menu

This menu is used for setting passwords and security features.

**Table 65. Security Menu**

| Feature                 | Options   | Description   |
|-------------------------|---|---|
| User Password Is        | No options  | Reports if there is a user password set.              |
| Unattended Start        | <ul style="list-style-type: none"> <li>• Enable</li> <li>• <b>Disable (default)</b></li> </ul>                        | Used only if user password is enabled.                |
| Supervisor Password Is  | No options  | Reports if there is a supervisor password set.        |
| Set User Password       | Password can be up to six alphanumeric characters.  | Specifies the user password.                          |
| Set Supervisor Password | Password can be up to seven alphanumeric characters.  | Specifies the supervisor password.                    |
| Clear User Password     | No options  | Supervisor can clear user password.                   |
| User Access Level       | <ul style="list-style-type: none"> <li>• Limited</li> <li>• No Access</li> <li>• View Only</li> <li>• Full</li> </ul> | Specifies the level of user access by the supervisor. |

## 4.6 Power Menu

This menu is used for setting power management features.

**Table 66. Power Menu**

| Feature          | Options  | Description   |
|------------------|--|---|
| Power Management | <ul style="list-style-type: none"> <li>• Disabled</li> <li>• <b>Enabled (default)</b></li> </ul>   | Enables or disables the BIOS power management feature.                    |
| Inactivity Timer | <ul style="list-style-type: none"> <li>• Off</li> <li>• 1 Minute</li> <li>• 5 Minutes</li> <li>• 10 Minutes</li> <li>• <b>20 Minutes (default)</b></li> <li>• 30 Minutes</li> <li>• 60 Minutes</li> <li>• 120 Minutes</li> </ul> | Specifies the amount of time before the computer enters standby mode.     |
| Hard Drive       | <ul style="list-style-type: none"> <li>• Disabled</li> <li>• <b>Enabled (default)</b></li> </ul>   | Enables power management for hard disks during standby and suspend modes. |
| Video Power Down | <ul style="list-style-type: none"> <li>• Disabled</li> <li>• Standby</li> <li>• <b>Suspend (default)</b></li> <li>• Sleep</li> </ul>   | Specifies power management for video during standby and suspend modes.    |

## 4.7 Boot Menu

This menu is used for setting the boot features and the boot sequence.

**Table 67. Boot Menu**

| Feature  | Options  | Description   |
|--|--|---|
| Quick Boot   | <ul style="list-style-type: none"> <li>Disabled</li> <li><b>Enabled (default)</b></li> </ul>   | Enables the computer to boot without running certain POST tests.  |
| Quiet Boot   | <ul style="list-style-type: none"> <li>Disabled</li> <li><b>Enabled (default)</b></li> </ul>   | <p><i>Disabled</i> displays normal POST messages.</p> <p><i>Enabled</i> displays OEM logo instead of POST messages.</p>   |
| Scan User Flash Area   | <ul style="list-style-type: none"> <li><b>Disabled (default)</b></li> <li>Enabled</li> </ul>   | Enables the BIOS to scan the flash memory for user binary files that are executed at boot time.   |
| After Power Failure  | <ul style="list-style-type: none"> <li>Stays Off</li> <li><b>Last State (default)</b></li> <li>Power On</li> </ul>   | <p>Specifies the mode of operation if an AC/Power loss occurs.</p> <p><i>Stay Off</i> keeps the power off until the power button is pressed.</p> <p><i>Last State</i> restores the power state before power loss occurred.</p>  |
| On Modem Ring*   | <ul style="list-style-type: none"> <li><b>Stay Off (default)</b></li> <li>Power On</li> </ul>  | Specifies how the computer responds to an incoming call on an installed modem when the power is off.  |
| On LAN*  | <ul style="list-style-type: none"> <li>Stay Off</li> <li><b>Power On (default)</b></li> </ul>  | Specifies how the computer responds to a LAN wake-up event when the power is off.   |
| On PME*  | <ul style="list-style-type: none"> <li><b>Stay Off (default)</b></li> <li>Power On</li> </ul>  | Specifies how the computer responds to a PCI Power Management Enable wake-up event when the power is off.   |
| First Boot Device<br>Second Boot Device<br>Third Boot Device<br>Fourth Boot Device | <ul style="list-style-type: none"> <li>Disabled</li> <li>1st IDE-HDD (Note 1)</li> <li>2nd IDE-HDD</li> <li>3rd IDE-HDD</li> <li>4th IDE-HDD</li> <li>Floppy</li> <li>ARMD-FDD (Note 2)</li> <li>ARMD-HDD (Note 3)</li> <li>ATAPI CD-ROM</li> <li>SCSI</li> <li>Network</li> </ul> | <p>Specifies the boot sequence from the available devices. To specify the boot sequence:</p> <ol style="list-style-type: none"> <li>Select the boot device with &lt;↑&gt; or &lt;↓&gt;.</li> <li>Press &lt;Enter&gt; to set the selection as the intended boot device.</li> </ol> <p>The operating system assigns a drive letter to each boot device in the order listed. Changing the order of the devices changes the drive lettering.</p> <p>Not all of the devices in this list are available as second, third, and fourth boot devices.</p> <p>For the first boot device, default is Floppy; for the second boot device, it is 1st IDE, for the third boot device, it is ATAPI CD-ROM; and for the fourth boot device, it is Disabled.</p> |

\* This is only applicable in the APM mode and not ACPI.

Notes:

- HDD = Hard Disk Drive
- ARMD-FDD = ATAPI removable device - floppy disk drive
- ARMD-HDD = ATAPI removable device - hard disk drive

## 4.8 Exit Menu

This menu is used for exiting the Setup program, saving changes, and loading and saving defaults.

**Table 68. Exit Menu**

| <b>Feature</b>          | <b>Description</b>   |
|-------------------------|--|
| Exit Saving Changes     | Exits and saves the changes in CMOS SRAM.  |
| Exit Discarding Changes | Exits without saving any changes made in Setup.  |
| Load Setup Defaults     | Loads the factory default values for all the Setup options.  |
| Load Custom Defaults    | Loads the custom defaults for Setup options.   |
| Save Custom Defaults    | Saves the current values as custom defaults. Normally, the BIOS reads the Setup values from flash memory. If this memory is corrupted, the BIOS reads the custom defaults. If no custom defaults are set, the BIOS reads the factory defaults. |
| Discard Changes         | Discards changes without exiting Setup. The option values present when the computer was turned on are used.  |

# 5 Error Messages and Beep Codes

## What This Chapter Contains

|     |                                      |    |
|-----|--------------------------------------|----|
| 5.1 | BIOS Error Messages.....             | 89 |
| 5.2 | Port 80h POST Codes.....             | 91 |
| 5.3 | Bus Initialization Checkpoints ..... | 95 |

## 5.1 BIOS Error Messages

**Table 69. BIOS Error Messages**

| Error Message  | Explanation   |
|--|---|
| GA20 Error   | An error occurred with Gate-A20 when switching to protected mode during the memory test.                          |
| Pri Master HDD Error<br>Pri Slave HDD Error<br>Sec Master HDD Error<br>Sec Slave HDD Error   | Could not read sector from corresponding drive.   |
| Pri Master Drive - ATAPI Incompatible<br>Pri Slave Drive - ATAPI Incompatible<br>Sec Master Drive - ATAPI Incompatible<br>Sec Slave Drive - ATAPI Incompatible | Corresponding drive is not an ATAPI device. Run Setup to make sure device is selected correctly.                  |
| A: Drive Error<br>B: Drive Error   | No response from diskette drive.  |
| Cache Memory Error   | An error occurred while testing L2 cache. Cache memory may be bad.  |
| CMOS Battery Low   | The battery may be losing power. Replace the battery soon.  |
| CMOS Display Type Wrong  | The display type is different than what has been stored in CMOS. Check Setup to make sure type is correct.        |
| CMOS Checksum Bad  | The CMOS checksum is incorrect. CMOS memory may have been corrupted. Run Setup to reset values.                   |
| CMOS Settings Wrong  | CMOS values are not the same as the last boot. These values have either been corrupted or the battery has failed. |
| CMOS Date/Time Not Set   | The time and/or date values stored in CMOS are invalid. Run Setup to set correct values.                          |
| DMA Error  | Error during read/write test of DMA controller.   |
| FDC Failure  | Error while trying to access diskette drive controller.   |
| HDC Failure  | Error while trying to access hard disk controller.  |

continued

**Table 69. BIOS Error Messages** (continued)

| <b>Error Message</b>  | <b>Explanation</b>  |
|---|---|
| Update Failed   | NVRAM was invalid but was unable to be updated.   |
| Unlock Keyboard   | The system keyboard lock is engaged. The system must be unlocked to continue to boot.                   |
| Keyboard Error  | Error in the keyboard connection. Make sure keyboard is connected properly.                             |
| KB/Interface Error  | Keyboard Interface Test failed.   |
| Timer Error   | Timer Test failed.  |
| Memory Size Changed   | Memory size has changed since the last boot. If no memory was added or removed, then memory may be bad. |
| Serial presence detect (SPD) device data missing or inconclusive. Do you wish to boot at 100 MHz bus speed? [Y/N] | System memory does not appear to be SPD memory.   |
| No Boot Device Available  | System did not find a boot device.  |
| Off Board Parity Error  | A parity error occurred on an offboard card. This error is followed by an address.                      |
| On Board Parity Error   | A parity error occurred in onboard memory. This error is followed by an address.                        |
| Parity Error  | A parity error occurred in onboard memory at an unknown address.  |
| NVRAM / CMOS / PASSWORD cleared by Jumper   | NVRAM, CMOS, and passwords have been cleared. The system should be powered down and the jumper removed. |
| <CTRL_N> Pressed  | CMOS is ignored and NVRAM is cleared. User must enter Setup.  |

## 5.2 Port 80h POST Codes

During the POST, the BIOS generates diagnostic progress codes (POST codes) to I/O port 80h. If the POST fails, execution stops and the last POST code generated is left at port 80h. This code is useful for determining the point where an error occurred.

Displaying the POST codes requires an add-in card (often called a POST card). The POST card can decode the port and display the contents on a medium such as a seven-segment display. These cards can be purchased from JDR Microdevices or other sources.

The following tables provide the POST codes that can be generated by the BIOS. Some codes are repeated in the table because a given code applies to more than one operation.

**Table 70. Uncompressed INIT Code Checkpoints**

| Code | Description of POST Operation  |
|------|--|
| D0   | NMI is disabled. Onboard keyboard controller and real time clock enabled (if present). Initialization code checksum verification starting.   |
| D1   | Keyboard controller BAT test, CPU ID saved, and going to 4GB flat mode.  |
| D3   | Initialize chipset, start memory refresh, and determine memory size.   |
| D4   | Verify base memory.  |
| D5   | Initialization code to be copied to segment 0 and control to be transferred to segment 0.  |
| D6   | Control is in segment 0. Used to check if in recovery mode and to verify main BIOS checksum. If in recovery mode or if main BIOS checksum is wrong, go to check point E0 for recovery. Otherwise, go to check point D7 to give control to main BIOS. |
| D7   | Find main BIOS module in ROM image.  |
| D8   | Uncompress the main BIOS module.   |
| D9   | Copy main BIOS image to F000 shadow RAM and give control to main BIOS in F000 shadow RAM.  |

**Table 71. Boot Block Recovery Code Checkpoints**

| Code | Description of POST Operation  |
|------|--|
| E0   | Onboard diskette controller (if any) is initialized. Compressed recovery code is uncompressed at F000:0000 in shadow RAM. Give control to recovery code at F000 in shadow RAM. Initialize interrupt vector tables, system timer, DMA controller, and interrupt controller. |
| E8   | Initialize extra (Intel recovery) module.  |
| E9   | Initialize diskette drive.   |
| EA   | Try to boot from diskette. If reading of boot sector is successful, give control to boot sector code.  |
| EB   | Boot from diskette failed; look for ATAPI (LS-120, Zip) devices.   |
| EC   | Try to boot from ATAPI device. If reading of boot sector is successful, give control to boot sector code.  |
| EF   | Boot from diskette and ATAPI device failed. Give two beeps. Retry the booting procedure (go to check point E9).  |

**Table 72. Runtime Code Uncompressed in F00 Shadow RAM**

| Code | Description of POST Operation   |
|------|---|
| 03   | NMI is Disabled. Check soft reset/power-on.   |
| 05   | BIOS stack set. Disable cache if any.   |
| 06   | Uncompress POST code.   |
| 07   | Initialize processor and initialize processor data area.  |
| 08   | Next, calculate CMOS checksum.  |
| 0B   | Next, do any initialization before executing keyboard BAT.  |
| 0C   | Keyboard controller I/B free. Issue the BAT command to keyboard controller.   |
| 0E   | Any initialization after keyboard controller BAT to be done next.   |
| 0F   | Write keyboard command byte.  |
| 10   | Issue pin 23, 24 blocking/unblocking command.   |
| 11   | Check whether <INS>, <END> keys were pressed during power on.   |
| 12   | Initialize CMOS if "Init CMOS in every boot" is set or if <END> key is pressed. Then disable DMA and interrupt controllers.             |
| 13   | Video display is disabled and port B is initialized. Chipset initialization about to begin.   |
| 14   | 8254 Timer Test is about to start.  |
| 19   | Memory Refresh Test is about to start.  |
| 1A   | Memory Refresh line is toggling. Check 15 $\mu$ s ON/OFF time.  |
| 23   | Read 8042 input port and disable Megakey GreenPC feature. Make BIOS code segment writeable.   |
| 24   | Do any setup before interrupt vector initialization.  |
| 25   | Interrupt vector initialization to begin. Clear password if necessary.  |
| 27   | Next, do any initialization before setting video mode.  |
| 28   | Set monochrome mode and color mode.   |
| 2A   | Start initialization of different buses, if present (system, static, output devices). (See Section 5.3 for details of different buses.) |
| 2B   | Give control for any setup required before optional video ROM check.  |
| 2C   | Look for optional video ROM and give control.   |
| 2D   | Give control to do any processing after video ROM returns control.  |
| 2E   | If EGA/VGA not found, then execute Display Memory R/W Test.   |
| 2F   | EGA/VGA not found. Display Memory R/W Test about to begin.  |
| 30   | Display Memory R/W Test passed. Look for the retrace checking.  |
| 31   | Display Memory R/W Test or retrace checking failed. Do Alternate Display Memory R/W Test.   |
| 32   | Alternate Display Memory R/W Test passed. Look for the alternate display retrace checking.  |
| 34   | Video display checking complete. Next, set display mode.  |
| 37   | Display mode set. Then display the power-on message.  |
| 38   | Start initialization of different buses, if present (input, IPL, general devices). (See Section 5.3 for details of different buses.)    |
| 39   | Display different buses initialization error messages. (See Section 5.3 for details of different buses.)                                |
| 3A   | New cursor position read and saved. Ready to display the Hit <DEL> message.   |

continued

**Table 72. Runtime Code Uncompressed in F00 Shadow RAM (continued)**

| Code | Description of POST Operation  |
|------|--|
| 40   | Prepare the descriptor tables.   |
| 42   | Enter virtual mode for memory test.  |
| 43   | Enable interrupts for diagnostics mode.  |
| 44   | Initialize data to check memory wrap-around at 0:0.  |
| 45   | Data initialized. Check for memory wrap-around at 0:0, and find the total system memory size.  |
| 46   | Memory wrap-around test done. Memory size calculation complete. Ready to write patterns to test memory.  |
| 47   | Pattern to be tested written in extended memory. Next, write patterns in base 640 K memory.  |
| 48   | Patterns written in base memory. Find amount of memory below 1 M.  |
| 49   | Amount of memory below 1 M found and verified. Find out amount of memory above 1 M.  |
| 4B   | Amount of memory above 1 M found and verified. Check for soft reset and clear memory below 1 M for soft reset. (If power on, go to check point 4Eh). |
| 4C   | Memory below 1 M cleared. (Soft reset) Clear memory above 1 M.   |
| 4D   | Memory above 1 M cleared. (Soft reset) Save the memory size. (Go to checkpoint 52h).   |
| 4E   | Memory test started. (Not Soft Reset) Ready to display the first 64 K memory size.   |
| 4F   | Memory size display started. This will be updated during memory test. Run sequential and random memory test.   |
| 50   | Memory testing/initialization below 1M complete. Ready to adjust displayed memory size for relocation/shadow.  |
| 51   | Memory size display adjusted due to relocation/shadow. Memory test above 1 M to follow.  |
| 52   | Memory testing/initialization above 1 M complete. Ready to save memory size information.   |
| 53   | Memory size information is saved. Processor registers are saved. Ready to enter real mode.   |
| 54   | Shutdown successful, processor in real mode. Ready to disable gate A20 line and disable parity/NMI.  |
| 57   | Successfully disabled A20 address line and parity/NMI. Ready to adjust memory size depending on relocation/shadow.                                   |
| 58   | Memory size adjusted for relocation/shadow. Ready to clear Hit <DEL> message.  |
| 59   | Hit <DEL> message cleared. <WAIT...> message displayed. Ready to start DMA and Interrupt Controller Test.  |
| 60   | DMA Page Register Test passed. Ready to start DMA#1 Base Register Test.  |
| 62   | DMA#1 Base Register Test passed. Ready to start DMA#2 Base Register Test.  |
| 65   | DMA#2 Base Register Test passed. Ready to program DMA unit 1 and 2.  |
| 66   | DMA unit 1 and 2 programming complete. Ready to initialize 8259 interrupt controller.  |
| 7F   | Extended NMI sources enabling is in progress.  |
| 80   | Keyboard test started. Clearing output buffer, checking for stuck key. Next, issue keyboard reset command.   |
| 81   | Keyboard reset error/stuck key found. Ready to issue keyboard controller interface test command.   |
| 82   | Keyboard controller interface test complete. Ready to write command byte and initialize circular buffer.   |
| 83   | Command byte written, global data initialization complete. Check for lock-key.   |

continued

**Table 72. Runtime Code Uncompressed in F000 Shadow RAM (continued)**

| Code | Description of POST Operation  |
|------|--|
| 84   | Lock-key checking complete. Next, check for memory size mismatch with CMOS.  |
| 85   | Memory size check complete. Next, display soft error and check for password or bypass Setup.   |
| 86   | Password checked. Ready to do programming before Setup.  |
| 87   | Programming before Setup complete. Uncompress Setup code and execute.  |
| 88   | Returned from CMOS Setup program and cleared screen. Ready to do programming after Setup.  |
| 89   | Programming after Setup complete. Display power-on message.  |
| 8B   | First screen message displayed. <WAIT...> message displayed. PS/2 mouse check and extended BIOS data area allocation to be done.                 |
| 8C   | Ready to start Setup options programming.  |
| 8D   | Ready to reset hard disk controller.   |
| 8F   | Hard disk controller reset complete. Floppy setup to be done next.   |
| 91   | Floppy setup complete. Hard disk setup to be done next.  |
| 95   | Start initialization of different buses optional ROMs from C800. (See Section 5.3 for details of different buses.)                               |
| 96   | Ready to do any init before C800 optional ROM control.   |
| 97   | Any initialization before C800 optional ROM control is complete. Next, do optional ROM check and control.  |
| 98   | Optional ROM control is complete. Next, give control to do any required processing after optional ROM returns control and enable external cache. |
| 99   | Do any initialization required after optional ROM Test is over. Ready to set up timer data area and printer base address.                        |
| 9A   | Return after setting timer and printer base address. Ready to set the RS-232 base address.   |
| 9B   | Returned after RS-232 base address. Ready to do any initialization before coprocessor test.  |
| 9C   | Required initialization before coprocessor test is complete. Ready to initialize coprocessor next.   |
| 9D   | Coprocessor initialized. Ready to do any initialization after Coprocessor Test.  |
| 9E   | Initialization after Coprocessor Test is complete. Ready to check extended keyboard, keyboard ID, and NumLock.                                   |
| A2   | Ready to display any soft errors.  |
| A3   | Soft error display complete. Ready to set keyboard typematic rate.   |
| A4   | Keyboard typematic rate set. Ready to program memory wait states.  |
| A5   | Ready to enable parity/NMI.  |
| A7   | NMI and parity enabled. Ready to do any initialization required before giving control to optional ROM at E000.                                   |
| A8   | Initialization before E000 ROM control complete. E000 ROM to get control next.   |
| A9   | Returned from E000 ROM control. Ready to do any initialization required after E000 optional ROM control.   |
| AA   | Initialization after E000 optional ROM control complete. Ready to display the system configuration.  |
| AB   | Put INT13 module runtime image to shadow RAM.  |
| AC   | Generate MP for multiprocessor support, if present.  |
| AD   | Put CGA INT10 module, if present, in shadow RAM.   |

continued

**Table 72. Runtime Code Uncompressed in F000 Shadow RAM** (continued)

| Code | Description of POST Operation  |
|------|--|
| AE   | Uncompress SMBIOS module, initialize SMBIOS code, and form the runtime SMBIOS image in shadow RAM. |
| B1   | Ready to copy any code to specific area.   |
| 00   | Copying of code to specific area complete. Ready to give control to INT19 boot loader.             |

### 5.3 Bus Initialization Checkpoints

The system BIOS gives control to the different buses at the following checkpoints to do various tasks.

| Checkpoint | Description   |
|------------|---|
| 2A         | Different buses init (system, static, output devices) to start, if present. |
| 38         | Different buses init (input, IPL, general devices) to start, if present.    |
| 39         | Display different buses initialization error messages.                      |
| 95         | Initialization of different buses optional ROMs from C800 to start.         |

While control is inside the different bus routines, additional checkpoints are output to port 80h as word values to identify the routines under execution. In these word-value checkpoints, the low byte of the checkpoint is the system BIOS checkpoint from which the control is passed to the different bus routines. The high byte of the checkpoint is the indication of which routine is being executed in the different buses.

The upper nibble of the high byte indicates the function being executed.

| Value | Description                                   |
|-------|---|
| 0     | func#0, disable all devices on this bus       |
| 1     | func#1, initialize static devices on this bus |
| 2     | func#2, initialize output device on this bus  |
| 3     | func#3, initialize input device on this bus   |
| 4     | func#4, initialize IPL device on this bus     |
| 5     | func#5, initialize general device on this bus |
| 6     | func#6, report errors on this bus             |
| 7     | func#7, initialize add-on ROM on all buses    |

The lower nibble of the high byte indicates the bus on which the routines are being executed.

| Value | Description                                 |
|-------|---|
| 0     | Generic DIM (Device Initialization Manager) |
| 1     | Onboard system devices                      |
| 2     | ISA devices                                 |
| 3     | EISA devices                                |
| 4     | ISA PnP devices                             |
| 5     | PCI devices                                 |

## 5.4 Speaker

A 47  $\Omega$  inductive speaker is mounted on the motherboard. The speaker provides audible error code (beep code) information during the power-on self test (POST).

## 5.5 BIOS Beep Codes

Whenever a recoverable error occurs during power-on self test (POST), the BIOS displays an error message describing the problem. The BIOS also issues a beep code (one long tone followed by two short tones) during POST if the video configuration fails (a faulty video card or no card installed) or if an external ROM module does not properly checksum to zero.

An external ROM module (for example, a video BIOS) can also issue audible errors, usually consisting of one long tone followed by a series of short tones. For more information on the beep codes issued, check the documentation for that external device.

There are several POST routines that issue a POST terminal error and shut down the system if they fail. Before shutting down the system, the terminal-error handler issues a beep code signifying the test point error, writes the error to I/O port 80h, attempts to initialize the video and writes the error in the upper left corner of the screen (using both monochrome and color adapters).

If POST completes normally, the BIOS issues one short beep before passing control to the operating system.

**Table 73. Beep Codes**

| Beep | Description                                     |
|------|---|
| 1    | Refresh failure                                 |
| 2    | Parity cannot be reset                          |
| 3    | First 64 KB memory failure                      |
| 4    | Timer not operational                           |
| 5    | Not used  |
| 6    | 8042 GateA20 cannot be toggled                  |
| 7    | Exception interrupt error                       |
| 8    | Display memory R/W error                        |
| 9    | Not used  |
| 10   | CMOS Shutdown register test error               |
| 11   | Invalid BIOS (e.g. POST module not found, etc.) |

## 5.6 Enhanced Diagnostics (Optional)

The enhanced diagnostics feature consists of a hardware decoder and four LEDs located between the audio connectors and the serial port A connector on the back panel. This feature requires no modifications to the chassis (other than I/O back panel shield) or cabling.

Figure 18 shows the location of the diagnostics LEDs. Table 74 lists the diagnostic codes displayed by the LEDs.

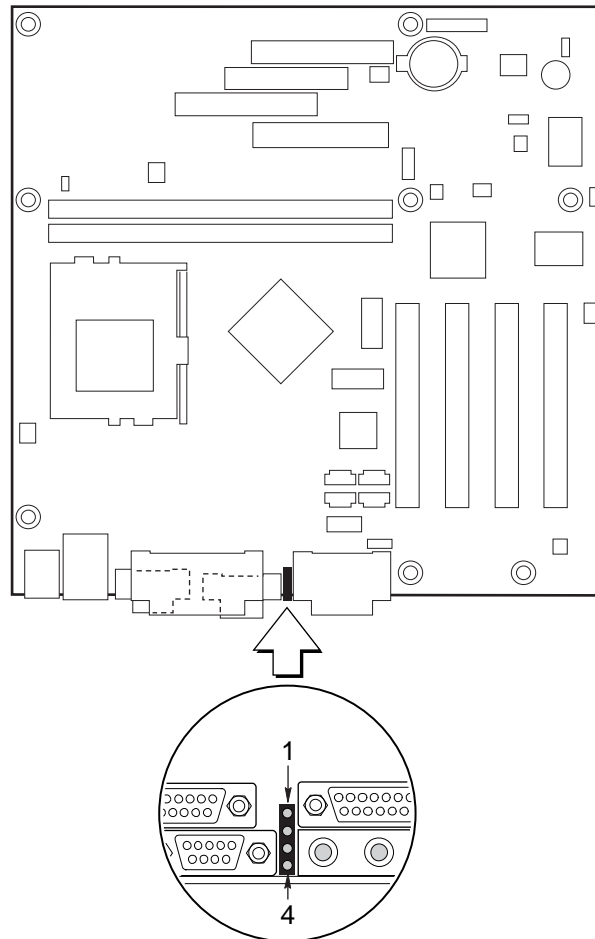

OM07763

**Figure 18. Enhanced Diagnostics LEDs**

**Table 74. Diagnostic LED Codes**

| Display |                                  | BIOS Operation                 |
|---------|----------------------------------|--------------------------------|
| 1       | Amber<br>Amber<br>Amber<br>Amber | Power on, starting BIOS        |
| 1       | Amber<br>Amber<br>Amber<br>Green | Recovery mode                  |
| 1       | Amber<br>Amber<br>Green<br>Amber | Processor, cache, etc.         |
| 1       | Amber<br>Amber<br>Green<br>Green | Memory, autosize, shadow, etc. |
| 1       | Amber<br>Green<br>Amber<br>Amber | PCI bus initialization         |
| 1       | Amber<br>Green<br>Amber<br>Green | Video                          |
| 1       | Amber<br>Green<br>Green<br>Amber | IDE bus initialization         |
| 1       | Amber<br>Green<br>Green<br>Green | USB initialization             |
| 1       | Green<br>Amber<br>Amber<br>Amber | Undefined                      |
| 1       | Green<br>Amber<br>Amber<br>Green | Undefined                      |
| 1       | Green<br>Amber<br>Green<br>Amber | Undefined                      |
| 1       | Green<br>Amber<br>Green<br>Green | Undefined                      |
| 1       | Green<br>Green<br>Amber<br>Amber | Undefined                      |
| 1       | Green<br>Green<br>Green<br>Green | Undefined                      |
| 1       | Green<br>Green<br>Green<br>Amber | Reserved                       |
| 1       | Green<br>Green<br>Green<br>Green | Booting operating system       |

# 6 Specifications and Customer Support

---

## What This Chapter Contains

|                          |    |
|--------------------------|----|
| 6.1 Online Support.....  | 99 |
| 6.2 Specifications ..... | 99 |

### 6.1 Online Support

Find information about Intel boards at these World Wide Web sites:

<http://support.intel.com/support/motherboards/desktop/>

<http://www.intel.com/>

### 6.2 Specifications

The motherboard implements the following standards, specifications, and design guidelines:

**Table 75. Compliance with Specifications**

| Specification | Description   | Revision Level  |
|---------------|---|---|
| AC '97        | Audio Codec '97 Component Specification                       | Revision 2.1, May 22, 1998, Intel Corporation. This specification is available at:<br><a href="http://developer.intel.com/pc-supp/platform/ac97/">http://developer.intel.com/pc-supp/platform/ac97/</a>                             |
| ACPI          | Advanced Configuration and Power Interface specification      | Revision 1.0a, July 1, 1998, Intel Corporation, Microsoft Corporation, and Toshiba Corporation. The specification is available at:<br><a href="http://www.teleport.com/~acpi/">http://www.teleport.com/~acpi/</a>                   |
| AGP           | Accelerated Graphics Port Interface Specification (1X and 2X) | Revision 2.0, May 4, 1998, Intel Corporation. The specification is available through the Accelerated Graphics Port Implementers Forum at:<br><a href="http://www.agpforum.org/">http://www.agpforum.org/</a>                        |
| AMI BIOS      | American Megatrends BIOS Specification                        | AMIBIOS 98. This specification is available at<br><a href="http://www.amibios.com">http://www.amibios.com</a>   |
| APM           | Advanced Power Management BIOS Interface Specification        | Revision 1.2, February, 1996, Intel Corporation and Microsoft Corporation. This specification is available at:<br><a href="http://www.microsoft.com/hwdev/busbios/amp_12.htm">http://www.microsoft.com/hwdev/busbios/amp_12.htm</a> |
| ATA-3         | Information Technology - AT Attachment-3 Interface            | X3T10/2008D Revision 6. The specification is available at the ATA Anonymous FTP Site:<br><a href="http://fission.dt.wdc.com">fission.dt.wdc.com</a> .   |
| ATAPI         | ATA Packet Interface for CD-ROMs                              | SFF-8020i Revision 2.5.<br>(SFF) Fax Access: (408) 741-1600.  |

continued

**Table 75. Compliance with Specifications** (continued)

| Specification               | Description  | Revision Level  |
|-----------------------------|--|---|
| ATX                         | ATX form factor specification  | Revision 2.03, December 1998, Intel Corporation. The specification is available at: <a href="http://developer.intel.com/design/motherbd/atx.htm">http://developer.intel.com/design/motherbd/atx.htm</a>   |
| DDC2B                       | Display Data Channel Standard  | Version 3.0, Level 2B protocols, Video Electronics Standards Association (VESA). The specification is available at: <a href="http://www.vesa.org">http://www.vesa.org</a>   |
| EI Torito                   | Bootable CD-ROM format specification   | Version 1.0, January 25, 1995<br>Phoenix Technologies Ltd., and IBM Corporation. The EI Torito specification is available on the Phoenix Web site at: <a href="http://www.phoenix.com/products/specs.html">http://www.phoenix.com/products/specs.html</a>   |
| EPP                         | Enhanced Parallel Port   | IEEE 1284 standard, Mode [1 or 2], v1.7, v1.9   |
| IrDA                        | Serial Infrared Physical Layer Link specification  | Version 1.1, October 17, 1995<br>Infrared Data Association.   |
| microATX                    | microATX Motherboard Interface Specification   | Version 1.0, December 1997, Intel Corporation. The specification is available at: <a href="http://www.teleport.com/~microatx/spec/">http://www.teleport.com/~microatx/spec/</a>   |
| LPC                         | Low Pin Count Interface Specification  | Revision 1.0, September 29, 1997, Intel Corporation. This specification is available at: <a href="http://www.intel.com/design/chipsets/industry/lpc.htm">http://www.intel.com/design/chipsets/industry/lpc.htm</a>  |
| PCI                         | PCI Local Bus Specification<br><br>PCI Power Management Interface Specification  | Revision 2.2, December 18, 1998, PCI Special Interest Group.<br><br>Revision 1.1, December 18, 1998, PCI Special Interest Group.<br><br>These specifications can be ordered at: <a href="http://www.pcisig.com/">http://www.pcisig.com/</a>   |
| Plug and Play               | Plug and Play BIOS specification   | Version 1.0a, May 5, 1994<br>Compaq Computer Corporation, Phoenix Technologies Ltd., and Intel Corporation.   |
| SDRAM DIMMs (64-and 72-bit) | PC SDRAM Unbuffered DIMM Specification<br>PC SDRAM DIMM Specification<br>PC Serial Presence Detect (SPD) Specification | Revision 1.0, February 1998, Intel Corporation.<br><br>Revision 1.63, October 1998, Intel Corporation.<br>Revision 1.2A, December 1997, Intel Corporation.<br>These specifications are available at: <a href="http://developer.intel.com/design/chipsets/memory/">http://developer.intel.com/design/chipsets/memory/</a>  |
| SMBIOS                      | System Management BIOS Reference Specification   | Version 2.3, August 12, 1998,<br>American Megatrends Inc., Award Software International Inc., Compaq Computer Corporation, Dell Computer Corporation, Hewlett-Packard Company, Intel Corporation, Phoenix Technologies Ltd., and SystemSoft Corporation. The specification is available at: <a href="http://developer.intel.com/ial/WfM/design/smbios/">http://developer.intel.com/ial/WfM/design/smbios/</a> |
| UHCI                        | Universal Host Controller Interface (UHCI) Design Guide  | Revision 1.1, March 1996, Intel Corporation. This specification is available at: <a href="http://www.usb.org/developers/">http://www.usb.org/developers/</a>  |

continued

**Table 75. Compliance with Specifications** (continued)

| Specification | Description                                 | Revision Level   |
|---------------|---|--|
| USB           | Universal serial bus specification          | Revision 1.1, September 23, 1998<br>Compaq Computer Corporation, Digital Equipment Corporation, IBM PC Company, Intel Corporation, Microsoft Corporation, NEC, and Northern Telecom.<br>This specification is available at:<br><a href="http://www.usb.org/developers/">http://www.usb.org/developers/</a> |
| WfM           | Wired for Management Baseline Specification | Version 2.0, December 18, 1998, Intel Corporation.<br>This specification is available at:<br><a href="http://developer.intel.com/ial/wfm/wfmspecs.htm">http://developer.intel.com/ial/wfm/wfmspecs.htm</a>   |

