

Premiere/PCI LC

Jumpers and Connectors

PLEASE NOTE

This motherboard product is no longer being manufactured by Intel.

THESE DOCUMENTS ARE PROVIDED FOR HISTORICAL REFERENCE PURPOSES ONLY AND ARE SUBJECT TO THE TERMS SET FORTH IN THE "LEGAL INFORMATION" LINK ON THE INTEL WEBSITE. For information on currently available Intel products, please see <http://www.intel.com> and/or <http://developer.intel.com>.

Jumpers

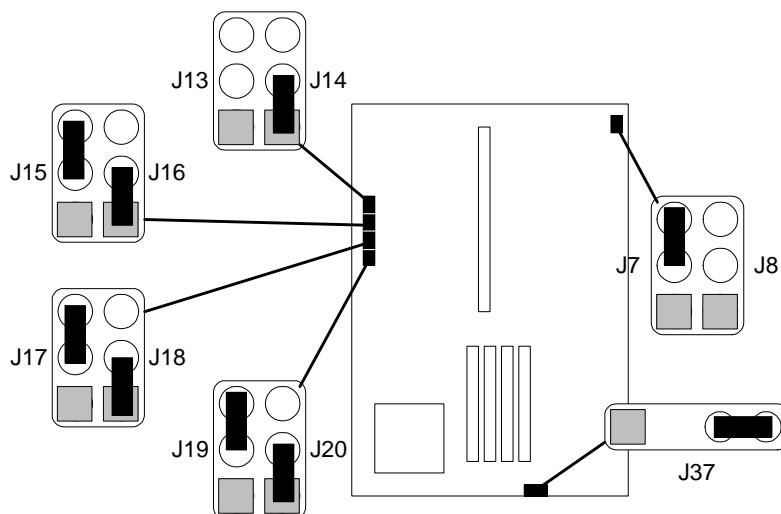

Figure B-1. Jumper locations and settings (■ denotes Pin 1)

FUNCTION	JUMPER	CONFIGURATION
CPU Voltage (5.0V/5.25V)	J7	1-2 CPU Vcc=5.00v for 60 MHz 2-3 CPU Vcc=5.25v for 66 MHz
Not used	J8	N/A
Not used	J13	N/A
CPU Speed	J14 CPU CLK	1-2 66 MHz 2-3 60 MHz
VGA Mode	J15 COLOR	1-2 MONO 2-3 COLOR (default)
Password	J16 PW	1-2 Normal (Enabled) (default) 2-3 Clear (Disabled)
Flash Boot Block	J17 BB	1-2 Recovery Mode 2-3 Normal Mode (default)
Flash Write Enable/Disable	J18 WP	1-2 Flash Write Enabled (default) 2-3 Flash Write Protected
CMOS Clear	J19 CMOS CLR	1-2 Clear 2-3 Normal (default)
CMOS Setup	J20 SETUP	1-2 Enable (default) 2-3 Disable
Ext. Speaker Header/Jumper	J37 SPKR	3-4 Enable on-board speaker Remove to disable

Table B-1. System Board Jumper Default Settings

Connectors

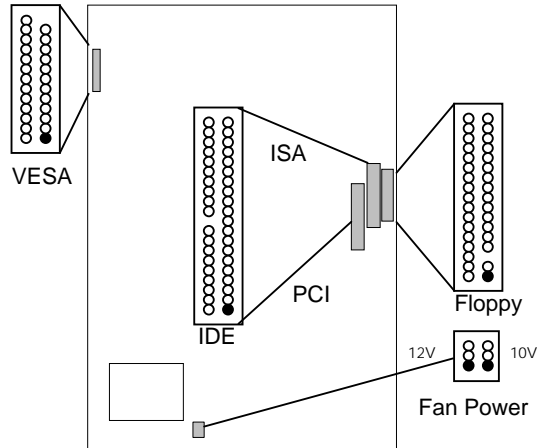

Figure 4. Premiere/PCI LC LPX Internal Connections (• denotes Pin 1).

VESA FEATURE CONNECTOR

Signal Name	Pin	Pin	Signal Name
Ground	1	2	Data 0
Ground	3	4	Data 1
Ground	5	6	Data 2
Data enable	7	8	Data 3
Sync enable	9	10	Data 4
PCLK enable	11	12	Data 5
Vcc	13	14	Data 6
Ground	15	16	Data 7
Ground	17	18	PCLK
Ground	19	20	BLANK
Ground	21	22	
Vcc	23	24	
	25	26	Ground

IDE CONNECTOR

Signal Name	Pin	Pin	Signal Name
Reset IDE	1	2	Ground
Host Data 7	3	4	Host Data 8
Host Data 6	5	6	Host Data 9
Host Data 5	7	8	Host Data 10
Host Data 4	9	10	Host Data 11
Host Data 3	11	12	Host Data 12
Host Data 2	13	14	Host Data 13
Host Data 1	15	16	Host Data 14
Host Data 0	17	18	Host Data 15
Ground	19	20	Key
DRQ3	21	22	Ground
I/O Write-	23	24	Ground
I/O Read-	25	26	Ground
IOCHRDY	27	28	BALE
DACK3-	29	30	Ground
IRQ14	31	32	IOCS16-
Addr 1	33	34	Ground
Addr 0	35	36	Addr 2
Chip Select 0-	37	38	Chip Select 1-
Activity	39	40	Ground

FLOPPY CONNECTOR

Signal Name	Pin	Pin	Signal Name
Ground	1	2	FDHDIN
Ground	3	4	Reserved
Key	5	6	FDEDIN
Ground	7	8	Index-
Ground	9	10	Motor Enable A-
Ground	11	12	Drive Select B-
Ground	13	14	Drive Select A-
Ground	15	16	Motor Enable B-
Ground	17	18	DIR-
Ground	19	20	STEP-
Ground	21	22	Write Data-
Ground	23	24	Write Gate-
Ground	25	26	Track 00-
Ground	27	28	Write Protect-
Ground	29	30	Read Data-
Ground	31	32	Side 1 Select-
Ground	33	34	Diskette

12V FAN POWER

Pin	Signal Name
1	Ground
2	+12 V (fused)
3	Ground

AUXILIARY 10V FAN POWER

Pin	Signal Name
1	Ground
2	+10 V (fused)
3	Ground

PS/2 STYLE MOUSE/KEYBOARD

Pi	Signal Name
1	Data
2	No Connect
3	Ground
4	Vcc (fused)
5	Clock
6	No Connect

PRIMARY POWER

Pi	Name	Function
1	PWRGD	Power Good
2	+5 V	+ 5 volts Vcc
3	+12 V	+ 12 volts
4	-12 V	- 12 volts
5	GND	Ground
6	GND	Ground
7	GND	Ground
8	GND	Ground
9	-5 V	-5 volts
10	+5 V	+ 5 volts Vcc
11	+5 V	+ 5 volts Vcc
12	+5 V	+ 5 volts Vcc

AUXILIARY (3.3V) POWER

Pin	Name	Function
1	GND	Ground
2	GND	Ground
3	GND	Ground
4	+3.3 V	+ 3.3 volts
5	+3.3V	+ 3.3 volts
6	+3.3 V	+ 3.3 volts

RESET SW

	Signal Name
1	RESET
2	Key
3	Ground

POWER LED

Pin	Signal Name
1	LED_PWR+5V
2	Ground

HARD DRIVE LED (DISK)

Pin	Signal Name
1	+5V
2	HD ACTIVE-
3	Key
4	+5V

TURBO LED

Pin	Signal Name
1	+5V
2	TURBO LED-

KEYLOCK SW

Pin	Signal Name
1	Keylock
2	Ground

STANDBY SW

Pin	Signal Name
1	EXTSMI
2	Ground

SPEAKER CONNECTOR

Pin	Signal Name
1	+5V Vcc
2	Key
3	On Board Speaker
4	SPKR_DAT

SERIAL PORTS

Pin	Signal Name
1	DCD* (Data Carrier Detect)
2	SIN (Serial Input)
3	SOUT (Serial Output)
4	DTR* (Data Terminal Ready)
5	Ground
6	DSR* (Data Set Ready)
7	RTS* (Request to Send)
8	CTS* (Clear to Send)
9	RI* (Ring Indicator)

PARALLEL PORT CONNECTOR

Signal Name	Pin	Pin	Signal Name
STROBE-	1	2	AUTO FEED-
Data Bit 0	3	4	ERROR-
Data Bit 1	5	6	INIT-
Data Bit 2	7	8	SLCT IN-
Data Bit 3	9	10	Ground
Data Bit 4	11	12	Ground
Data Bit 5	13	14	Ground
Data Bit 6	15	16	Ground
Data Bit 7	17	18	Ground
ACJ-	19	20	Ground
BUSY	21	22	Ground
PE (Paper End)	23	24	Ground
SLCT	25		

VIDEO MONITOR PORT

Pin	Signal Name
1	Red
2	Green
3	Blue
4	No Connect
5	Ground
6	Ground
7	Ground
8	Ground
9	No Connect
10	Ground
11	No Connect
12	No Connect
13	Horizontal Sync.
14	Vertical Sync.
15	No Connect

PCI RISER CONNECTOR (J9F1)

Signal Name	Pin	Pin	Signal Name
IOCHK-	A1	B1	GND
SD7	A2	B2	RSTDRV
SD6	A3	B3	Vcc
SD5	A4	B4	IRQ9
SD4	A5	B5	-5V
SD3	A6	B6	DRQ2
SD2	A7	B7	-12V
SD1	A8	B8	0WS-
SD0	A9	B9	+12V
IOCHRDY	A1	B10	GND
AEN	A1	B11	SMEMW-
SA19	A1	B12	SMEMR-
SA18	A1	B13	IOW-
SA17	A1	B14	IOR-
SA16	A1	B15	DACK3-
SA15	A1	B16	DRQ3
SA14	A1	B17	DACK1-
SA13	A1	B18	DRQ1
SA12	A1	B19	REFRESH-
SA11	A2	B20	SYSCLK
SA10	A2	B21	IRQ7
SA9	A2	B22	IRQ6
SA8	A2	B23	IRQ5
SA7	A2	B24	IRQ4
SA6	A2	B25	IRQ3
SA5	A2	B26	DACK2-
SA4	A2	B27	TC
SA3	A2	B28	BALE
SA2	A2	B29	Vcc
SA1	A3	B30	OSC
SA0	A3	B31	GND
SBHE-	C1	D1	MEMCS16-
LA23	C2	D2	IOCS16-
LA22	C3	D3	IRQ10
LA21	C4	D4	IRQ11
LA20	C5	D5	IRQ12
LA19	C6	D6	IRQ13
LA18	C7	D7	IRQ14
LA17	C8	D8	DACK0-
MEMR-	C9	D9	DRQ0
MEMW-	C1	D10	DACK5-
SD8	C1	D11	DRQ5
SD9	C1	D12	DACK6-
SD10	C1	D13	DRQ6
SD11	C1	D14	DACK7-
SD12	C1	D15	DRQ7
SD13	C1	D16	Vcc
SD14	C1	D17	MASTER-
SD15	C1	D18	GND

Signal Name	Pin	Pin	Signal Name
GND	E1	F1	GND
GND	E2	F2	GND
PCIINT1-	E3	F3	PCIINT3-
PCIINT2-	E4	F4	PCIINT4-
Vcc	E5	F5	Vcc
Key	E6	F6	Key
Vcc	E7	F7	Vcc
PCIRST-	E8	F8	PCLKF
GNT0-	E9	F9	GND
REQ0-	E1	F10	GNT1-
GND	E1	F11	GND
PCLKE	E1	F12	REQ1-
GND	E1	F13	AD31
AD30	E1	F14	AD29
3.3V	E1	F15	3.3V
Key	E1	F16	Key
3.3V	E1	F17	3.3V
AD28	E1	F18	AD27
AD26	E1	F19	AD25
AD24	E2	F20	CBE3-
AD22	E2	F21	AD23
AD20	E2	F22	AD21
AD18	E2	F23	AD19
3.3V	E2	F24	3.3V
Key	E2	F25	Key
3.3V	E2	F26	3.3V
AD16	E2	F27	AD17
FRAME-	E2	F28	IRDY-
CBE2-	E2	F29	DEVSEL-
TRDY-	E3	F30	PLOCK-
STOP-	E3	F31	PERR-
SDONE	G1	H1	SERR-
SBO-	G2	H2	AD15
CBE1-	G3	H3	AD14
PAR	G4	H4	AD12
GND	G5	H5	GND
Key	G6	H6	Key
GND	G7	H7	GND
AD13	G8	H8	AD10
AD11	G9	H9	AD8
AD9	G1	H10	AD7
CBE0-	G1	H11	AD5
AD6	G1	H12	AD3
AD4	G1	H13	AD1
AD2	G1	H14	AD0
Key	G1	H15	Key
Vcc	G1	H16	Vcc
Vcc	G1	H17	Vcc
GND	G1	H18	GND
GND	G1	H19	GND

PCI CONNECTORS 1,2, AND 3 (J10B1, J10C1, J10C2)

Signal Name	Pin	Pin	Signal Name
GND	A1	B1	-12V
+12V	A2	B2	No Connect
No Connect	A3	B3	GND
No Connect	A4	B4	No Connect
VCC	A5	B5	VCC
PCIINT3-	A6	B6	VCC
PCIINT1-	A7	B7	PCIINT2-
VCC	A8	B8	PCIINT4-
Reserved	A9	B9	No Connect
VCC	A10	B10	Reserved
Reserved	A11	B11	No Connect
GND	A12	B12	GND
GND	A13	B13	GND
Reserved	A14	B14	Reserved
SPCIRST-	A15	B15	GND
VCC	A16	B16	PCLKE
AGNT-	A17	B17	GND
GND	A18	B18	REQA-
Reserved	A19	B19	VCC
AD30	A20	B20	AD31
3.3V	A21	B21	AD29
AD28	A22	B22	GND
AD26	A23	B23	AD27
GND	A24	B24	AD25
AD24	A25	B25	3.3V
AD22 (IDSEL)	A26	B26	CBE3-
3.3V	A27	B27	AD23
AD22	A28	B28	GND
AD20	A29	B29	AD21
GND	A30	B30	AD19
AD18	A31	B31	3.3V

Signal Name	Pin	Pin	Signal Name
AD16	A32	B32	AD17
3.3V	A33	B33	CBE2-
FRAME-	A34	B34	GND
GND	A35	B35	IRDY-
TRDY-	A36	B36	3.3V
GND	A37	B37	DEVSEL-
STOP-	A38	B38	GND
3.3V	A39	B39	PLOCK-
SDONE	A40	B40	PERR-
SBO-	A41	B41	3.3V
GND	A42	B42	SERR-
PAR	A43	B43	3.3V
AD15	A44	B44	CBE1-
3.3V	A45	B45	AD14
AD13	A46	B46	GND
AD11	A47	B47	AD12
GND	A48	B48	AD10
AD9	A49	B49	GND
KEY	A50	B50	KEY
KEY	A51	B51	KEY
CBEO-	A52	B52	AD8
3.3V	A53	B53	AD7
AD6	A54	B54	3.3V
AD4	A55	B55	AD5
GND	A56	B56	AD3
AD2	A57	B57	GND
AD0	A58	B58	AD1
VCC	A59	B59	VCC
SREQ64-	A60	B60	SACK64-
VCC	A61	B61	VCC
VCC	A62	B62	VCC