

EUROCOM 8500 DeskNote User's Manual

This manual covers EUROCOM 8500P, 8500P3 and 8500C DeskNote™ models. All distinctions between models are covered throughout this manual. Enjoy your EUROCOM 8500 DeskNote.

Notice

The company reserves the right to make any updates revisions or changes to the information contained herein as and when deemed necessary. The company is under no obligation to notify any purchaser or end-user of such actions in advance or afterwards.

1999

Trademarks

DeskNote™ is a registered trademark of Eurocom Corporation

IBM PC, OS/2, PS/2, EGA, and VGA are registered trademarks of International Business Machines Corporation.

Intel, Pentium are registered trademarks of Intel Corporation.

MS-DOS, Microsoft Windows, Windows NT and Microsoft Mouse are registered trademarks of Microsoft Corporation.

Sound Blaster Pro is a registered trademark of Creative Labs, Inc.

SystemSoft is a registered trademark of SystemSoft Corp.

Other brand and product names are registered trademarks of their respective companies.













Table of Contents

| | |
|--|-------------|
| CHAPTER 1 : GETTING STARTED..... | 1-1 |
| UNPACKING THE DESKNOTE™..... | 1-2 |
| ▣ POWERING THE SYSTEM..... | 1-3 |
| AC Power Adapter..... | 1-3 |
| Battery Pack..... | 1-4 |
| Inserting..... | 1-4 |
| Removing..... | 1-4 |
| Recharging by AC Power..... | 1-5 |
| Proper Handling of the Battery Pack..... | 1-5 |
| ▣ OPENING THE LCD COVER..... | 1-6 |
| LED Indicators on the LCD Cover..... | 1-7 |
| ▣ TOP-FRONT VIEW..... | 1-8 |
| LCD Panel..... | 1-8 |
| Stereo Speakers..... | 1-8 |
| Trackpad and Buttons..... | 1-8 |
| Keyboard..... | 1-8 |
| Microphone..... | 1-8 |
| System Status LED Indicators..... | 1-9 |
| Power Button..... | 1-9 |
| ▣ REAR VIEW..... | 1-11 |
| ▣ RIGHT-SIDE VIEW..... | 1-13 |
| ▣ LEFT-SIDE VIEW..... | 1-15 |
| 5.25" CD-ROM Drive..... | 1-15 |
| Infrared..... | 1-15 |
| Left-side Stand..... | 1-16 |
| CHAPTER 2 : OPERATION..... | 2-17 |
| ▣ UPGRADING PROCESSOR MODULE..... | 2-18 |
| ON EUROCOM 8500P/3 DESKNOTE™..... | 2-18 |
| Replacing Processor Module..... | 2-19 |
| ▣ UPGRADING PROCESSOR MODULE..... | 2-20 |
| ON DESKNOTE 8500C..... | 2-20 |
| Replacing Processor Module..... | 2-20 |
| ▣ SETTING DIP SWITCH..... | 2-23 |
| Accessing DIP Switch (SW1)..... | 2-23 |
| ▣ EXPANDING MEMORY..... | 2-25 |
| Accessing the Memory Sockets..... | 2-26 |
| Installing Memory Module..... | 2-27 |
| Removing Memory Module..... | 2-28 |
| ▣ USING HARD DISK DRIVE..... | 2-29 |





| | |
|--|-------------|
| Removing..... | 2-29 |
| Replacing Hard Disk Drive..... | 2-30 |
| ▣ USING FLOPPY DISK DRIVE..... | 2-31 |
| Inserting/Removing Diskettes..... | 2-31 |
| Replacing Floppy Disk Drive..... | 2-32 |
| ▣ USING CD-ROM..... | 2-33 |
| Removing CD-ROM Module..... | 2-34 |
| Loading Compact Discs..... | 2-35 |
| Handling of Compact Discs..... | 2-36 |
| ▣ USING PC CARD SOCKETS..... | 2-37 |
| Inserting PC Cards..... | 2-38 |
| Removing PC Cards..... | 2-38 |
| ▣ USING HOT KEYS..... | 2-39 |
| Windows 95 Special Keys..... | 2-40 |
| ▣ USING NUMERIC KEYPAD..... | 2-41 |
| ▣ USING POWER MANAGEMENT..... | 2-42 |
| Advanced Power Management (APM 1.2)..... | 2-42 |
| Global Standby..... | 2-42 |
| Hard Disk Standby..... | 2-42 |
| Suspend and Resume..... | 2-43 |
| Powered On Suspend (POS)..... | 2-43 |
| Resume from POS Mode..... | 2-43 |
| Suspend To Disk (STD)..... | 2-44 |
| Resume from STD Mode..... | 2-44 |
| ▣ ATTACHING PERIPHERAL DEVICES..... | 2-45 |
| Attaching a Security Lock..... | 2-45 |
| Attaching a Parallel Printer..... | 2-46 |
| Attaching a TV Set..... | 2-47 |
| Attaching a Video Input Device..... | 2-48 |
| Attaching a USB-compatible Device..... | 2-49 |
| Attaching a Serial Mouse..... | 2-50 |
| Attaching an External Monitor (CRT)..... | 2-51 |
| Attaching a PS/2 Keyboard or Mouse..... | 2-52 |
| Attaching a Digital Camera..... | 2-53 |
| CHAPTER 3 : BIOS UTILITIES..... | 3-54 |
| ▣ POWER ON SELF TEST (POST)..... | 3-55 |
| POST Message: Normal Operation..... | 3-55 |
| POST Message: Error Detected..... | 3-56 |
| ▣ SYSTEM CONFIGURATION UTILITY..... | 3-57 |
| Information in the System Configuration Utility..... | 3-57 |
| Initiating the System Configuration Utility..... | 3-58 |
| Working with the Menu Bar..... | 3-59 |

| | |
|--|------|
| Working with the Pull-down Menu..... | 3-60 |
| Features of the System Configuration Utility | 3-61 |
| Startup Menu | 3-61 |
| Memory Menu | 3-63 |
| Disks Menu | 3-64 |
| Components Menu | 3-65 |
| Power Menu | 3-68 |
| Exit Menu | 3-71 |

CHAPTER 4 : TROUBLESHOOTING 4-1

| | |
|---|-----|
|  BATTERY | 4-2 |
|  POWER | 4-3 |
|  HARD DISK DRIVE | 4-3 |
|  FLOPPY DISK DRIVE | 4-4 |
|  HARDWARE INSTALLATION | 4-4 |
|  LCD PANEL | 4-5 |
|  MEMORY MODULE..... | 4-6 |
|  PC CARD | 4-6 |
|  BOOT PASSWORD..... | 4-7 |
|  AUDIO..... | 4-7 |
|  CD | 4-8 |
|  PRINTER..... | 4-9 |
|  ATI DVD PLAY (OPTION) | 4-9 |

CHAPTER 5 : INSTALLING DRIVERS..... 5-10

| | |
|--|------|
|  INSTALLING WINDOWS 95..... | 5-11 |
|  INSTALLING WINDOWS 98..... | 5-13 |
|  INSTALLING DRIVERS IN WINDOWS 95..... | 5-14 |
| Step 1: Installing USB Driver..... | 5-14 |
| Step 2: Installing TXPATCH Driver | 5-14 |
| Step 3: Installing VGA Driver | 5-14 |
| Step 4: Installing Audio Driver (1978S M2E)..... | 5-15 |
| Step 5: Installing PCMCIA driver | 5-15 |
| Step 6: Installing Video-in Driver..... | 5-16 |
| Step 7: Installing ATI DVD Play Driver (Option) | 5-16 |
| Step 8: Using Infrared Wireless Communication..... | 5-16 |
|  INSTALLING DRIVERS IN WINDOWS NT 4.0 | 5-17 |
| Step 1: Installing VGA Driver | 5-17 |
| Step 2: Installing Audio Driver (1978S M2E)..... | 5-17 |
|  INSTALLING DRIVERS IN WINDOWS 98..... | 5-18 |
| Step 1: Installing VGA Driver | 5-18 |
| Step 2: Installing Audio Driver (1978S M2E)..... | 5-18 |
| Step 3: Installing PCMCIA Driver | 5-19 |

| | |
|---|----------|
| Step 4: Installing Video-in Driver..... | 5-19 |
| Step 5: Installing ATI DVD Play Driver (Option) | 5-19 |
| APPENDIX A: SPECIFICATIONS..... | V |

Safety Notice

The computer is a delicate device that requires careful handling. Negligence or mistaken use may cause serious damage. Before you learn to operate or use this computer, you need to understand the instruction regarding safety handling.

The following mentions the incorrect handling that is seriously inhibited. To keep the computer from being damaged, please keep these precautions in mind.

Do not turn off the power during operation.

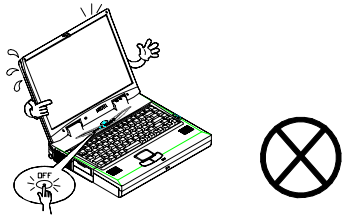

Do not place the computer on an unstable surface.

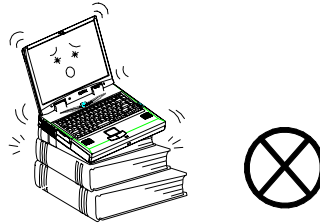

Do not turn off the peripheral device when the light is on.

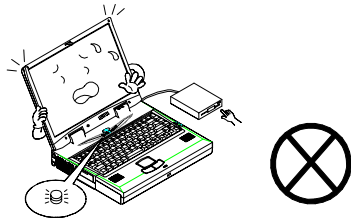

Do not touch the poisonous liquid when the LCD is broken.

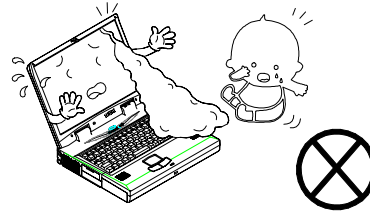

Do not disassemble the computer yourself.

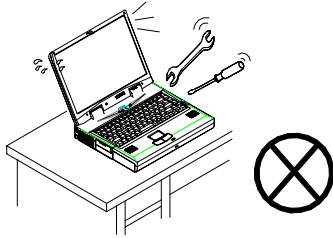

Do not place anything heavy on the computer.

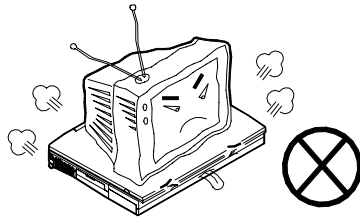

Do not touch power cord with a wet hand.

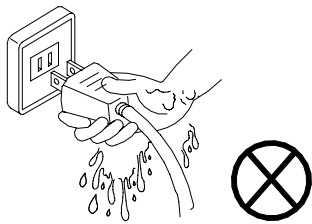

Do not use a broken power cord.

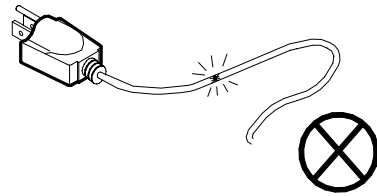

Keep the computer away from any metal appliance.

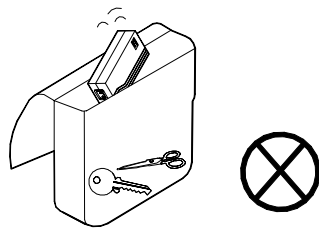

Do not throw the computer or accessories into fire.

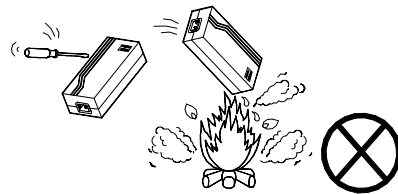

The following mentions the actions that are important for your DeskNote. To keep your DeskNote in excellent condition, please follow the instruction as much as possible.

If there is unusual odor, heat or smoke, unplug the power cord immediately.

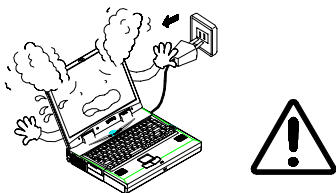

Unplug the power cord when attaching peripheral device.

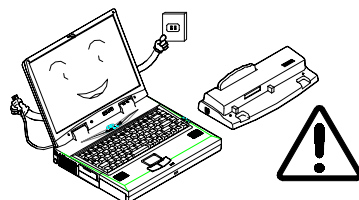

Follow the airline instructions when traveling with your DeskNote™.

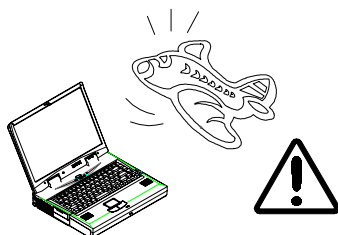

Use the appropriate accessory model of peripheral device for your DeskNote™.

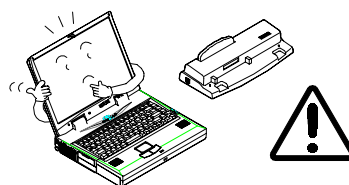

Maintain your computer regularly.

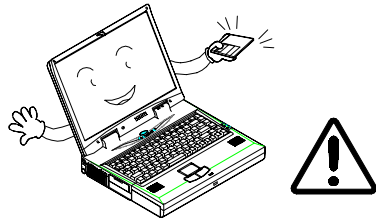

Do not place heavy things on the power cord.

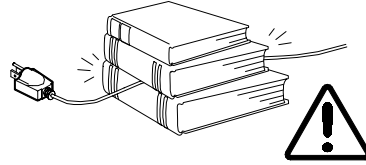

Affix tape to the contact plate while putting the battery into keeping box.

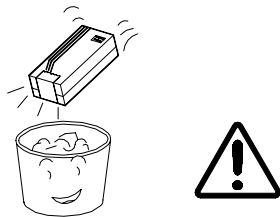

Take a rest after a long time of work.

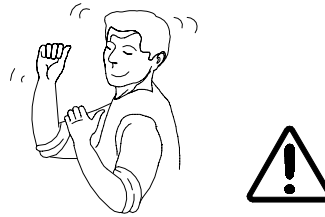

The data is easy to lose in low power status.

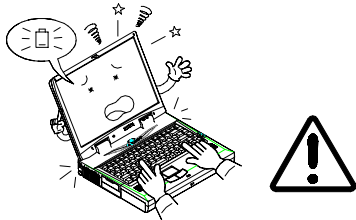

Please keep the computer away from humid environment.

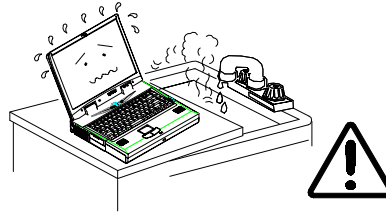

Conventions

This manual uses the following conventions to describe, identify, and highlight terms and operating procedures.

Text Conventions

Text in boldface contains messages that are important for safe operation. Please read.

Characters in boldface represent specific items or keys, e.g. **CardBus**, **Fn** key.

File names are presented in bold capitals, e.g. **A:\>0VMAKFIL —Pn**.

Abbreviations

For the purpose of clarity, abbreviations are enclosed in parentheses following their definition; for example, Enhanced Parallel Port (EPP) mode.

Icons

Icons identify ports and jacks of the DeskNote computer. The system status indicators are also identified with their relative icons.

Keys

Keys appear in boldface. A plus sign (+) between two keys indicates that they should be pressed simultaneously.

Messages

Note: A note is an advice that helps you make best use of your DeskNote™ computer. Please read.

Ergonomics

Developing good work habits are important if you need to work in front of your DeskNote™ for long periods of time. Improper work habits can result in discomfort or serious injury from repetitive strain to your hands, wrists or other joints. The following are some tips to reduce the strain:

- Adjust the chair and desk to make your elbow height near the height of keyboard. Keep your forearms, wrists, and hands in a relaxed position.
- Your knees should be slightly higher than your hips. Place your feet flat on the floor or on a footrest if necessary.
- Use a chair with a back and adjust it to support your lower back comfortably.
- Sit straight so that your knees, hips and elbows form approximately 90° angles when you are working.



Lighting

Proper lighting and comfortable display viewing angle can reduce the eye strain and muscle fatigue in your neck and shoulders.

- Position the display to avoid glare or reflections from overhead lighting or outside light sources.
- Keep the display screen clean and set the brightness and contrast to levels that allow you to see the screen clearly.
- Position the display directly in front of you at a comfortable viewing distance.
- Adjust the display-viewing angle to find the best position.

In addition, continuous concentration on computing work can result in discomfort and injury. Remember to:

- Alter your posture frequently.
- Stretch and exercise your body several times a day.
- Take periodic breaks when you work at the computer for long periods of time. Frequent and short breaks are of greater benefit than fewer and longer breaks.

Chapter 1 : Getting Started

This chapter provides you with the introduction to the DeskNote™ Computer. It will familiarize you to the DeskNote's features, components, operating environment and the power sources.

 **Unpacking your DeskNote™**

 **Features of the DeskNote™**

 **Operating environment**

 **Powering the system**

Unpacking the DeskNote™

Carefully unpack the DeskNote Computer and the included accessories (Figure 1-1). If there is any discrepancy or problem, contact your dealer immediately. Be sure to save the packing materials in the event that the DeskNote needs to be shipped in the future. The shipping carton should contain the following items:

- DeskNote computer
- CD with Drivers/Manuals
- PS/2 Y-Cable
- Carrying Bag
- Battery Pack
- Utilities Diskette
- Power Cord
- Power Adapter

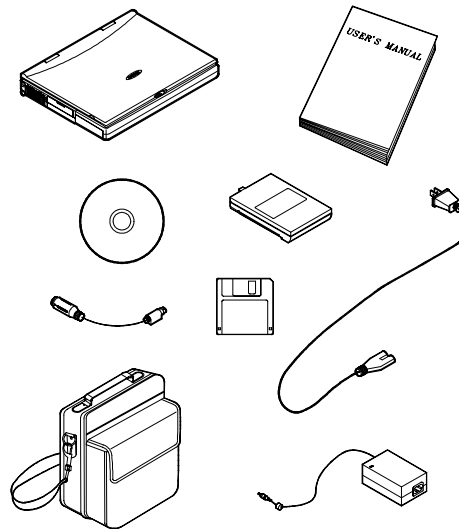

Figure 1-1

Powering the System

You can use the AC power adapter or battery pack to power the computer system.

AC Power Adapter

Use only the power adapter that comes with your computer. An incorrect type of power adapter will cause damage to the computer and its components.

1. Plug the power adapter cord into the AC-in socket on the rear panel of the computer.
2. Connect the power adapter with the power cord.
3. Plug the power cord into a properly grounded outlet (Figure 1-3).
4. Refer to Chapter 1, System Status LED Indicators for more information on system power status.

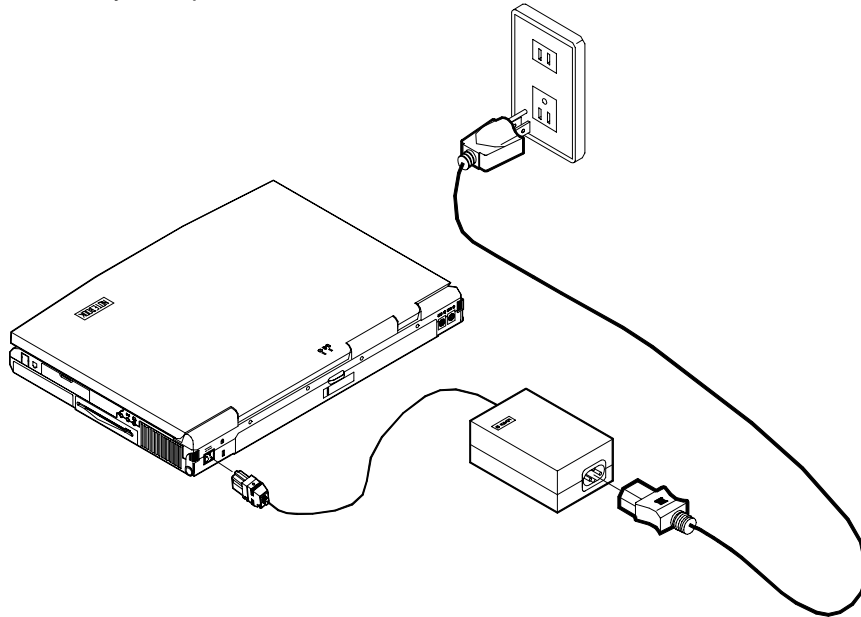

Figure 1-3

Battery Pack

The battery pack provides power for continuous portable operation of the computer. When using the battery no external power source is required. The actual operation time is related to the application and the configuration you're using.

Inserting

1. Turn the computer over.
2. Fit the battery pack firmly at a slight angle into the computer.
3. Install the four screws to fasten the battery pack (Figure 1-4).

Removing

1. Turn the computer over.
2. Remove the four screws that fasten the battery pack.
3. Carefully lift the battery pack from the computer.

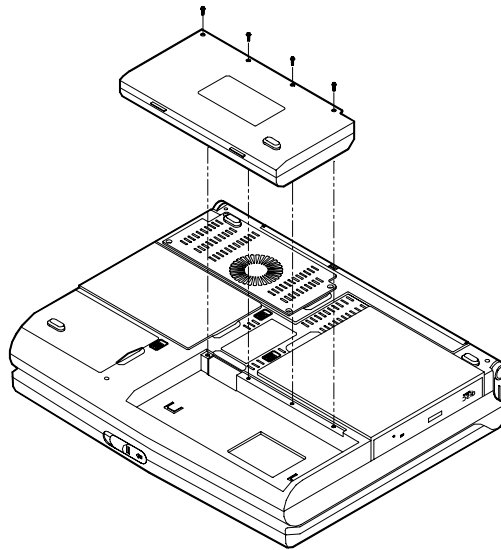

Figure 1-4

Recharging by AC Power

The battery pack can be recharged when the computer is connected to power supply with the AC adapter, when the system is in operation or not.

- Connect the computer to the power supply with AC adapter to begin charging system's battery pack. You do not need to turn off the DeskNote's power.
- Allow few (up to 5) hours to fully recharge the battery pack.
- Please refer to Chapter 1, System Status LED Indicators for more information on battery charge status.

Proper Handling of the Battery Pack

- Do not attempt to disassemble the battery under any circumstances.
- The battery may explode if exposed to fire or high temperatures.
- Avoid battery short circuit by preventing contact from the metal terminals (+, -).

Opening the LCD Cover

1. Move the latch to the right to release the top cover. (Figure 1-5).
2. Lift the top cover to reveal the LCD panel and keyboard (Figure 1-6).
3. Adjust the LCD panel to a comfortable viewing angle.
4. Press the power button to turn the system on or off (refer to Chapter 1, Top-Front View for more information of the power button).

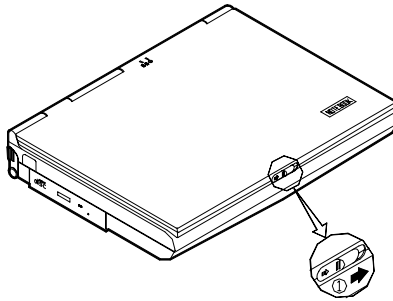

Figure 1-5

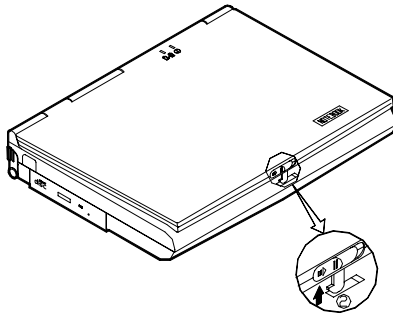

Figure 1-6

LED Indicators on the LCD Cover

| Icon | Color | Description |
|------|--------------|---|
| ⓘ | Green | Battery power is used with system turning on. |
| | Red | AC power is used with system turning on. |
| 🔋/🔌 | Green | Battery is fully charged. |
| | Red | Battery is being charged. |
| | Blinking Red | Battery power is critically low. |

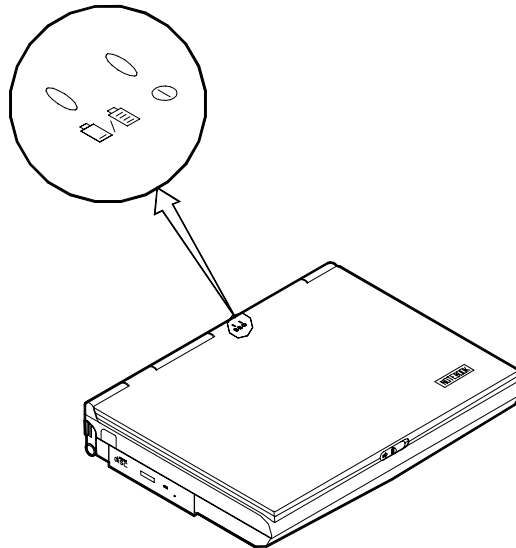

Figure 1-7

Top-Front View

LCD Panel

The EUROCOM 8500 DeskNote provides you with a large 15.1" TFT LCD panel. The LCD panel is driven by a AGP bus video controller with 8 MB video memory.

Stereo Speakers

Two built-in speakers provide clear stereo sound.

Trackpad and Buttons

The pointing device features a sensitive glide pad for precise movements. It functions like a two-button mouse does. The right trackpad button is equivalent to the right mouse button; the left trackpad button is equivalent to the left mouse button.

Keyboard

The computer features a 102-key Windows 95 keyboard that is integrated with the numeric keypad. It is detachable for various language versions. You may refer to Chapter 2: Operation for more information.



Microphone

This is the built-in microphone.

System Status LED Indicators

The LED indicators display the system's operation status.

| Icon | Color | Description |
|------|--------------|--|
| ⓘ | Green | Battery power is used with system turned on. |
| | Red | AC power is used with system turned on. |
| 🔋 | Green | Battery is fully charged. |
| | Red | Battery is being charged. |
| | Blinking Red | Battery power is critically low. |
| ⏸ | Green | The system has entered the configured suspend mode (either POS or STR mode). |
| 💾 | Green | The hard disk is being accessed. |

Power Button

| | |
|---|---|
| ⓘ | Use this button to turn the system on or off. |
| | After proper configuration under SCU, this button can be used as suspend/resume hot button (refer to Chapter 3: BIOS Utilities, Power Menu for more information). |

Note: After turning off the system, wait for a few seconds to power it on again.

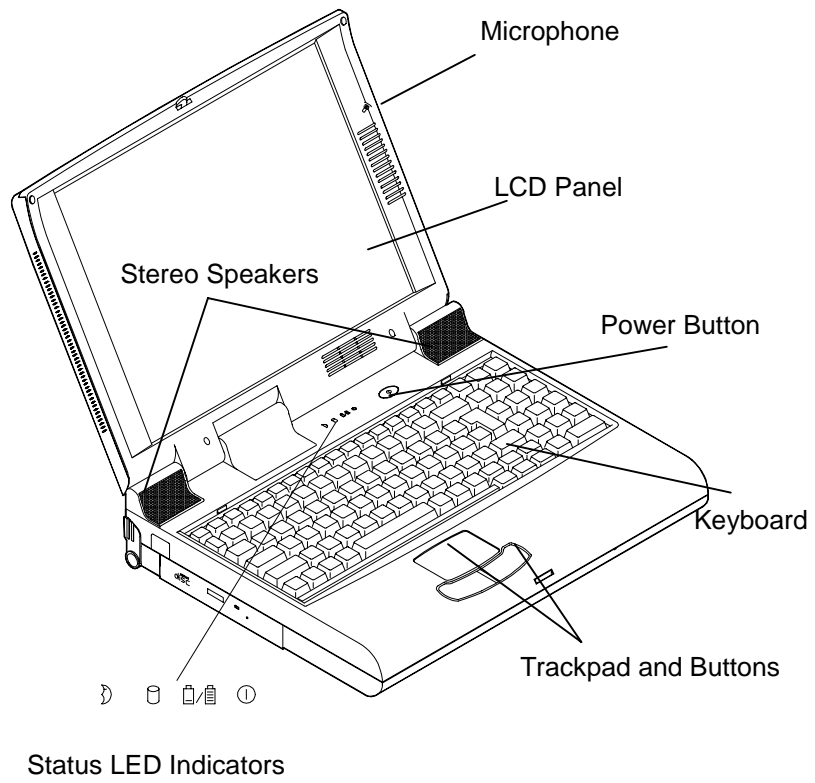

Figure 1-8

Rear View



AC-in Socket

Plug the AC adapter into this socket for power supply. To disconnect, pull the plug (not the cord) directly back.



Security Connector

The Security Connector is used to protect your computer from being stolen. Wrap the steel cable around your desk. Then, insert the locking device into this security connector.



Parallel Port

This parallel port supports EPP (Enhanced Parallel Port) and ECP (Extended Capabilities Port) modes.



S-Video Jack

Use this jack to transmit video signal to a TV set. You may need to select the video standard (NTSC/PAL) for video display (please refer to Chapter 3, Components Menu for more information).



RCA Jack

This jack accepts analog composite signals from external video devices, e.g. camera, CD.



Expansion Port

This port is used to connect the proprietary Port Replicator.



Dual USB Ports

The dual Universal Serial Bus (USB) ports simplify the expansion capability for peripheral devices.



Serial Port

This port is UART 16C550 compatible. It features a 9-pin connector for the addition of an external mouse for example.



External Monitor (CRT) Port

This port is used for transmission of the display to an external monitor. Simultaneous display with the LCD panel is available.



Dual PS/2 Type Ports

A PS/2 type mouse and keyboard can be connected to the system using these ports. However, you cannot connect the same type of PS/2 devices to both ports simultaneously.



1394 Port (8500P model only)

A newly developed port which connects with the digital camera.

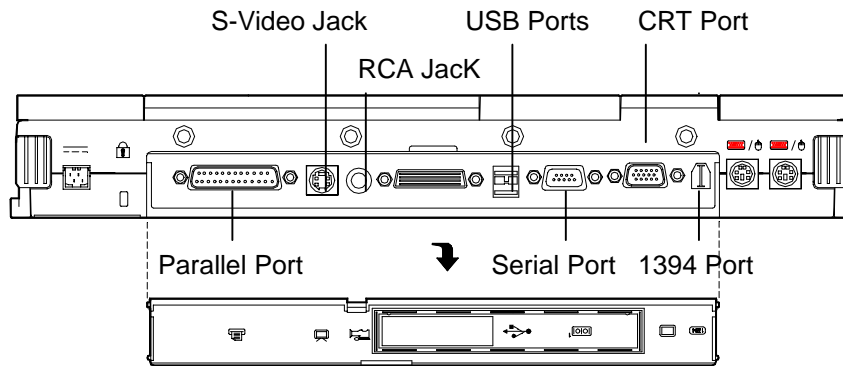

Figure 1-9

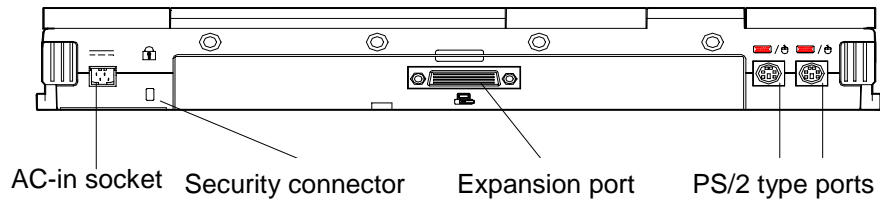

Figure 1-10

Right-Side View

PC Card Sockets

One Type III or two Type II PC cards can be used. Both sockets will expand the system capabilities when a PC card is inserted. To eject the PC card, press the appropriate eject button (Figure 2-15).

2.5" Hard Disk Drive

The 2.5" hard disk drive is removable. It accepts any 2.5" IDE hard disk drive with a height of 12.7mm or less. Refer to Chapter 2: "Operation" for more information.

3.5" Floppy Disk Drive

The computer comes standard with a 1.44MB floppy drive installed. Press the button on its top-right side to eject the diskette. The floppy disk module can be replaced with additional drive units, such as a secondary 2.5"/3.0" hard disk drive or Zip drive (Refer to Chapter 2: Operation for more information).

Speaker-out Jack



Headphone and speakers can be attached to the system through this jack.



Line-in Jack

External audio source can be fed into the computer through this jack.



Microphone-in Jack

Use this jack to connect a microphone to the system.

Ventilation

The computer vents were designed to help dissipate system's heat produced during normal operation. Do not block or obstruct vents while DeskNote™ is in use.

Right-side Stand

Move this stand (together with the left one) to adjust the typing angle. If a high speed CPU is installed, erecting the stands on both sides will be necessary for heat dissipation during operation (Figure 1-12)

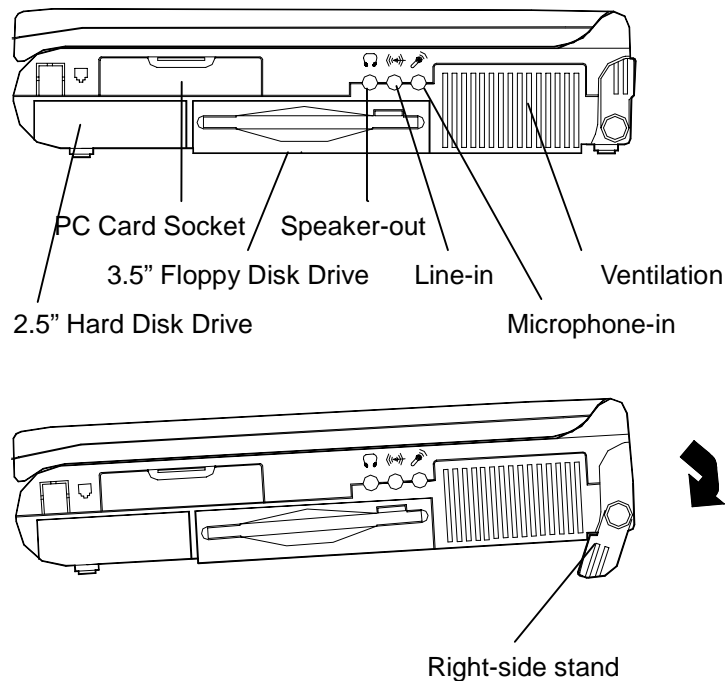

Figure 1-12

Left-Side View

5.25" CD-ROM Drive

The 5.25" IDE CD-ROM module is designed to be removable. The eject button is located in the middle of the front cover of the CD-ROM drive. Pressing it will release the CD tray.

Infrared

The system adopts infrared technology as the interface for simple, fast and convenient data exchange from the computer to an infrared-compatible device. It implements IrDA (HPSIR), Amplitude Shifted Keyed IR (ASKIR), and Fast IR (FIR). No object should be blocking the line of sight between the computer and the infrared-equipped device. For further information, please refer to the manual of the wireless device you wish to connect on how to use the point-and-shoot operation.

Left-side Stand

Move this stand (together with the right one) to adjust the typing angle. If a high speed CPU is installed on the system, erecting the stands on both sides will be necessary for heat dissipation during operation (Figure 1-14).

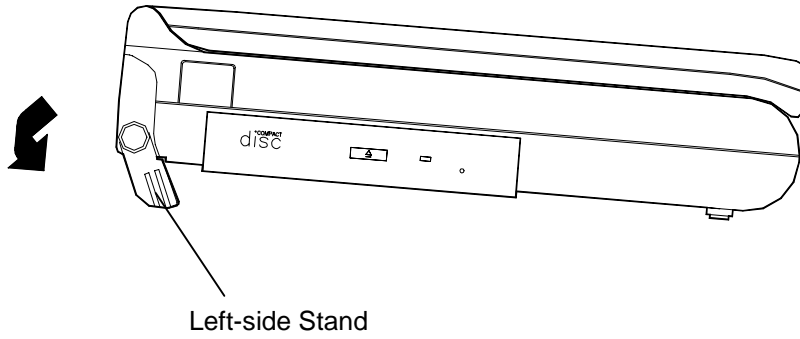
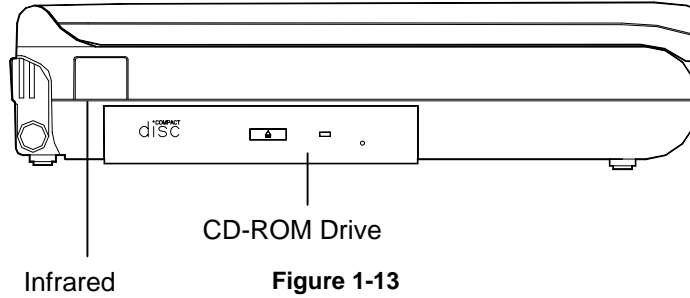











Chapter 2 : Operation

Your EUROCOM 8500 DeskNote has many advanced features to help you with your computer work. This chapter describes each of the computer's hardware features and shows you how to use them.

We strongly discourage EUROCOM DeskNote™ owners from servicing their systems. Service by untrained individual might result in serious damage to components inside DeskNote. Opening EUROCOM DeskNote™ might result in voiding warranty.

Before you begin working with the internal components of the computer, remove the battery and disconnect the AC power adapter.

Make sure you wear an anti-static wrist strap to ground yourself before working with or repair the internal components. Static electricity may damage the components.

-  *Upgrading Processor Module*
-  *Setting DIP Switch*
-  *Expanding Memory*
-  *Using Hard Disk Drive*
-  *Using Floppy Disk Drive*
-  *Using CD-ROM*
-  *Using PC Card Sockets*
-  *Using Hot Keys*
-  *Using Numeric Keypad*
-  *Using Power Management*
-  *Attaching Peripheral Devices*

Upgrading Processor Module **on EUROCOM 8500P/3 DeskNote™**

The DeskNote computer features the structure of Intel's Mobile Module (MMC2). The Processor Module incorporates an Intel Pentium Mobile processor, secondary cache, and the Intel PCI set "Northbridge" system controller, voltage regulator, and thermal sensor on a single printed circuit board.

The Processor Module is connected to the mainboard through a connector. This design facilitates users to easily upgrade their system by simply replacing the Processor Module.

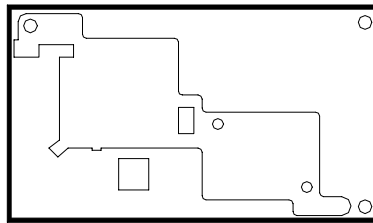

View from Top

Connector

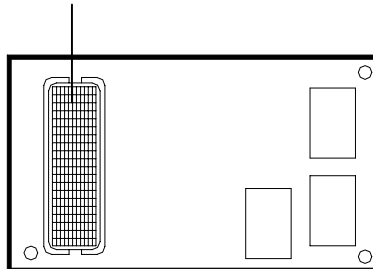

View from Bottom

Figure 2-1

Replacing Processor Module

1. Remove all power sources (AC power and battery).
2. Turn the computer over.
3. Remove the CPU cover.
4. Remove the screws that fasten the heat sink mounted on the Processor Module.
5. Carefully detach the Processor Module from the mainboard (Figure 2-2).

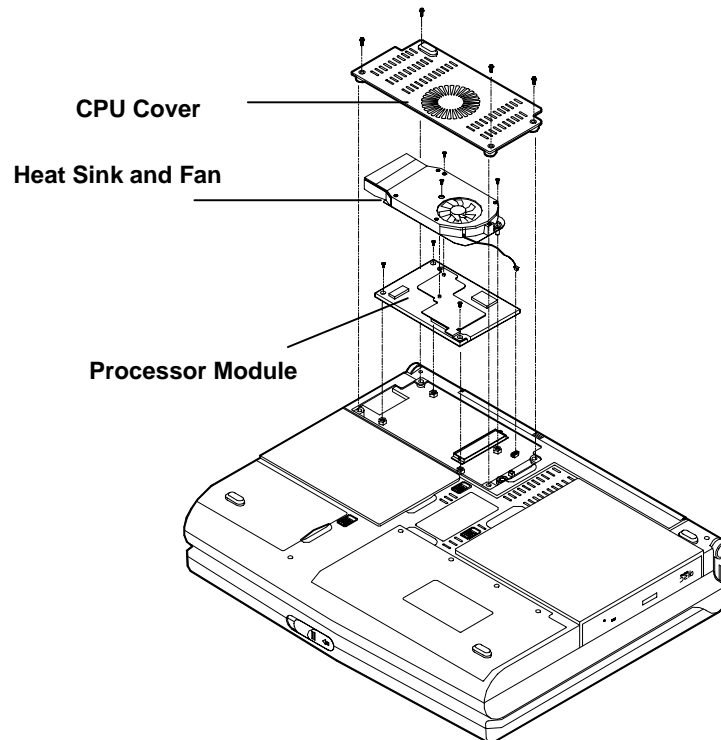

Figure 2-2

Upgrading Processor Module on DeskNote 8500C

Replacing Processor Module

6. Remove all power sources (AC power and battery).
7. Turn the computer over.
8. Remove the CPU cover.
9. Remove the screws that fasten the heat sink mounted on the Processor Module.
10. Carefully detach the Processor Module from the mainboard (Figure 2-1).

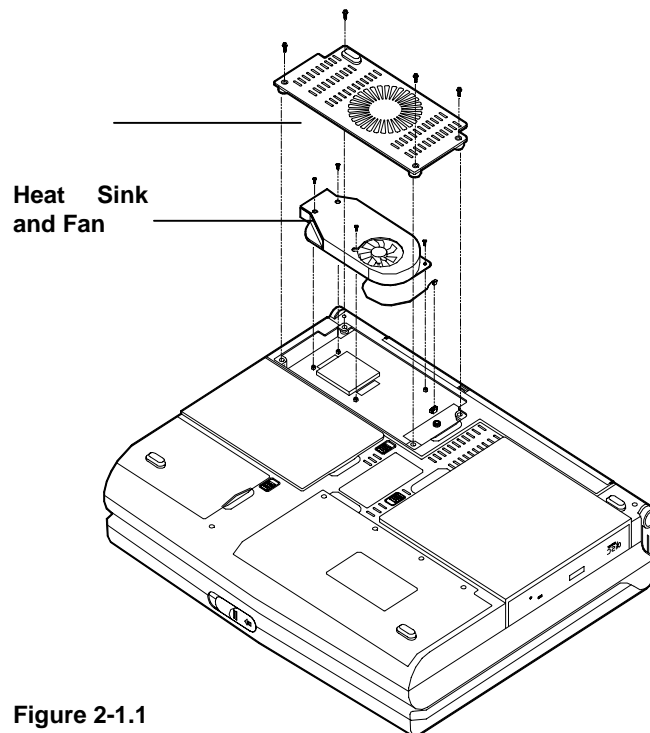

Figure 2-1.1

CPU Cover

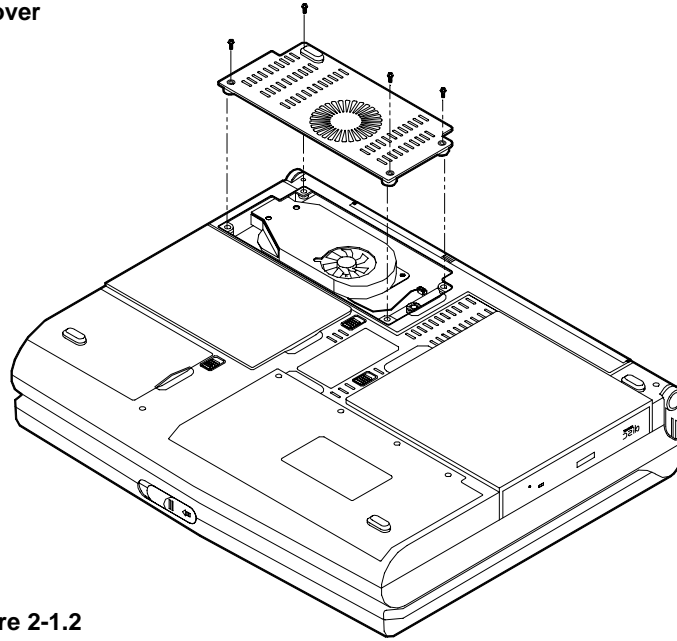

Figure 2-1.2

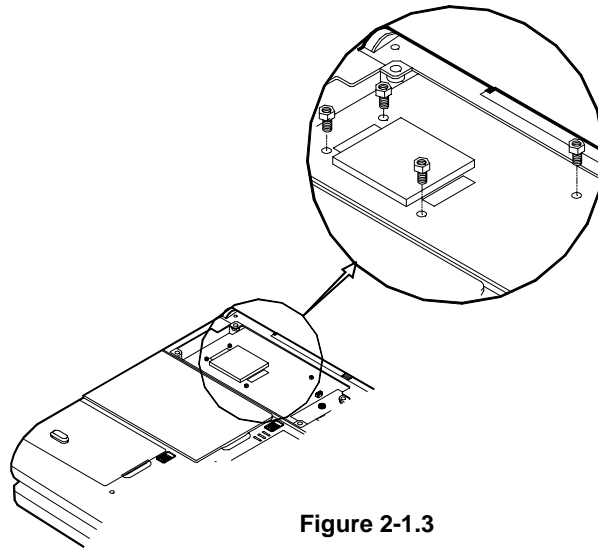

Figure 2-1.3

Reinstalling Heat Sink

Reinstall the CPU in the reverse order of removal. Make sure that the heat sink cable is properly installed. (Figure 2-2)

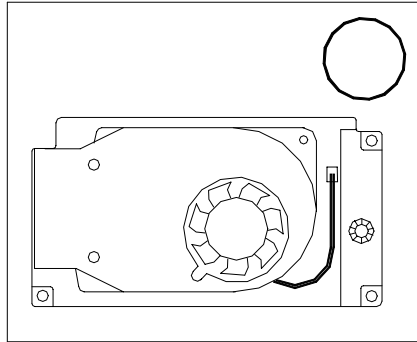
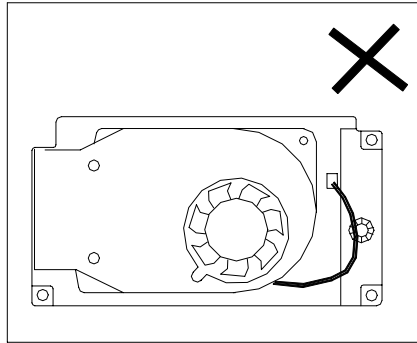

Figure 2-2



Setting DIP Switch

Remove the keyboard to reveal the system's mainboard. Locate the DIPSwitch (SW1) to set the correct configuration for the following purpose:

Flash ROM BIOS update

To upgrade your computer, you need to keep up with the latest system BIOS. Consult your dealer for further information. The DIPSwitch needs to be set in the **On** position when updating the existing system BIOS. The DIP Switches should be reset to the **Off** position after BIOS updating is complete.

| DIP Switch (SW1) | | Purpose |
|------------------|--------------|-----------------------|
| SW1-1 | SW1-2 | Flash ROM BIOS |
| Off | Off | Existing BIOS |
| On | On | Updating BIOS |

Accessing DIP Switch (SW1)

1. Turn the system power off.
2. Press the two keyboard latches to elevate the keyboard from its normal position (Figure 2-3).
3. Carefully lift the keyboard assembly out to expose the mainboard. Locate the DIPSwitch SW1 to set the configuration (Figure 2-4).

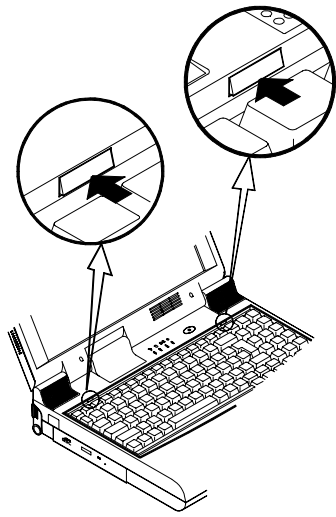

Figure 2-3

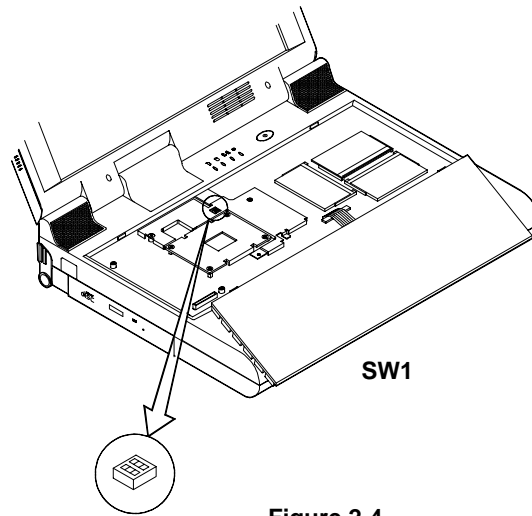

Figure 2-4

Expanding Memory

The EUROCOM 8500P/C DeskNote has three memory sockets for different RAM modules to expand the memory up to 384MB * EUROCOM 8500P3 DeskNote has two memory sockets for up to 256MB of RAM. The RAM modules should be 144-pin SODIMM (Small Outline Dual In-line Memory Module) type. The computer supports EDO, and SDRAM operation. The total memory size is automatically detected by the POST routines. To expand the memory, you have the following choice with different DRAM combinations:

| Bank 0 | Bank 1 | Bank 2 * | Total Size P3 | Total Size C/P2 |
|--------|--------|----------|---------------|-----------------|
| 32 | 0 | 0 | 32 | 32 |
| 32 | 32 | 0 | 64 | 64 |
| 32 | 32 | 32 | N/A | 96 |
| 64 | 0 | 0 | 64 | 64 |
| 64 | 32 | 0 | 96 | 96 |
| 64 | 32 | 32 | N/A | 128 |
| 64 | 64 | 0 | 128 | 128 |
| 64 | 64 | 32 | N/A | 160 |
| 64 | 64 | 64 | N/A | 192 |
| 128 | 0 | 0 | 128 | 128 |
| 128 | 32 | 0 | 160 | 160 |
| 128 | 32 | 32 | N/A | 192 |
| 128 | 64 | 0 | 192 | 192 |
| 128 | 64 | 32 | N/A | 224 |
| 128 | 64 | 64 | N/A | 256 |
| 128 | 128 | 0 | 256 | 256 |
| 128 | 128 | 32 | N/A | 288 |
| 128 | 128 | 64 | N/A | 320 |
| 128 | 128 | 128 | N/A | 384 |

Note: * Bank 2 might or might not be available on your system, Pentium III based systems are equipped with 2 memory sockets only.

Accessing the Memory Sockets

1. Turn the system power off.
2. Press the two keyboard latches to elevate the keyboard from its normal position (Figure 2-3).
3. Carefully lift the keyboard assembly out to expose the mainboard. Locate the memory sockets (Figure 2-5).

Note:

- The memory socket Bank 1 is a reverse type, make sure you install the memory module with reverse side to fit its connector.
- Please ensure that each edge of the memory module (SDRAM) has no component mounted on (see Figure 2-5.1). It is recommended to use the RAM module that complies with Intel unbuffered SO-DIMM (67.6mmX31.75mm). Please consult your dealer for detailed information.

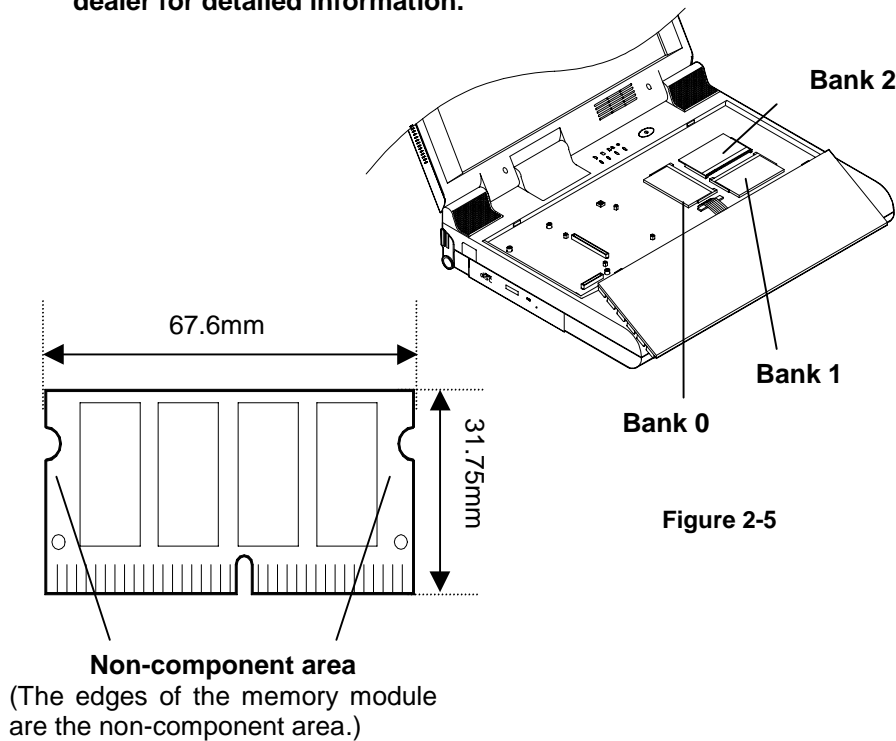

Figure 2-5.1

Installing Memory Module

Follow the steps below to install the memory module:

1. Turn the system power off.
2. Press the two keyboard latches to elevate the keyboard from its normal position (Figure 2-3).
3. Carefully lift the keyboard assembly out to expose the mainboard. Locate the memory sockets (Figure 2-5).
4. **Insert the memory module at a slight angle (45°) and fit its connectors into the socket firmly.**
5. **Press two edges of the memory module (as the arrows indicated) to make it locked into place** (Figure 2-6).
6. Reinstall the keyboard assembly.

Note:

Make sure you install the memory module in the order of Bank 0, Bank 1, Bank 2 (see Figure 2-5). Please refer to the table of DRAM combinations or consult your dealer for a proper installation.

Figure 2-6

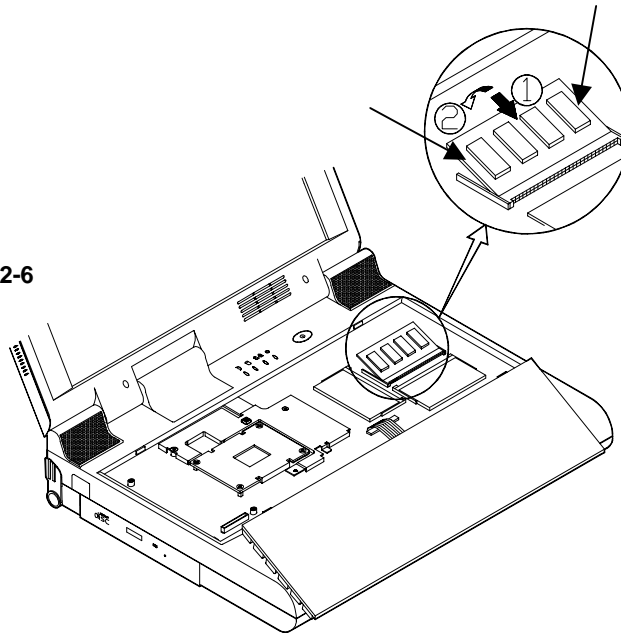

Removing Memory Module

1. Turn the system power off.
2. Press the two keyboard latches to elevate the keyboard from its normal position (Figure 2-3).
3. Carefully lift the keyboard assembly out to expose the mainboard. Locate the memory sockets (Figure 2-5).
4. Gently pull the two latches outward on both ends of the module. The module will pop up (Figure 2-7).
5. Remove the memory module.
6. Reinstall the keyboard assembly.

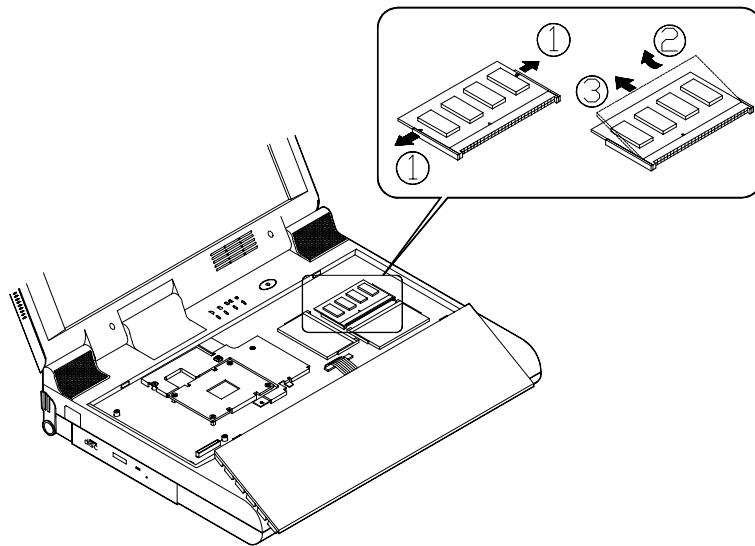

Figure 2-7

Using Hard Disk Drive

The hard disk drive is mounted in a removable case and can be taken out to accommodate other 2.5" IDE hard disk drives with a height of 12.7mm. The system supports drives with 2.0 GB capacities through the Logical Block Addressing (LBA) mode. It also supports Programmed I/O (PIO) mode 4, Bus Master IDE and provides a high performance data transfer rate at speeds up to 33 Mbytes/second (ATA-33).

Removing

1. Turn the system power off.
2. Turn the computer over.
3. Locate the Hard Disk Drive latch.
4. Press the latch in the direction indicated and take the hard disk drive out of the computer (Figure 2-8).

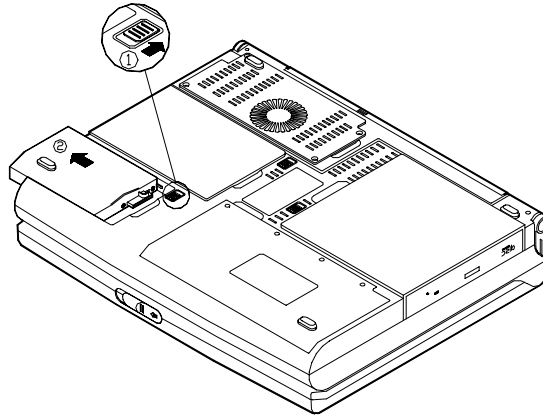

Figure 2-8

Note:

When inserting the hard disk drive, insert it firmly into the computer. Make sure you feel the drive click into the position when it is seated properly.

Replacing Hard Disk Drive

The hard disk drive is contained in a case. To take the hard disk drive out of the case and replace with another one, you need to remove the two screws on each side of the case (Figure 2-9). The location of the two screws may be varied depending on different types of hard disk model. Gently disconnect the cable from the hard disk drive when taking it out of the case. Be careful not to bend any pins or crimp the cable.

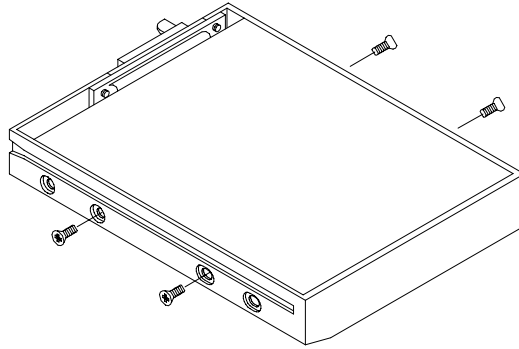

Figure 2-9

Using Floppy Disk Drive

The DeskNote computer comes standard with a 1.44MB, 3.5" floppy disk drive module. It is labeled drive A: and may be used as a boot device if properly set.

You may replace the floppy disk module with the following options: a 2.5" secondary hard disk drive (of 12.7mm or 17mm high), a 3.0" secondary hard disk drive (of 12.5mm high), a 100MB Zip drive (of 15mm high), or a LS-120 device (of 12.7mm high). Contact your dealer for details about these options.

Inserting/Removing Diskettes

When using the floppy drive, always insert your floppy diskette label-side up (Figure 2-10). To remove your diskette, press the eject button on the top-right corner of the floppy drive.

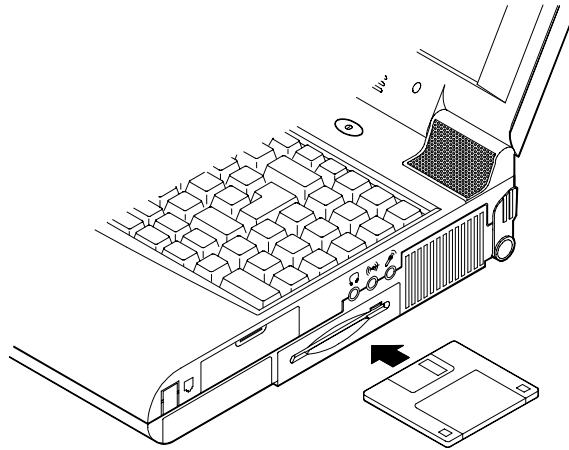

Figure 2-10

Replacing Floppy Disk Drive

1. Turn the system power off.
2. Turn the computer over.
3. Locate the Floppy Disk Drive latch.
4. Press the latch in the direction indicated and take the floppy disk drive out of the computer (Figure 2-11).
5. Insert the replacement drive (2.5"/3.0" secondary HDD or 100MB Zip drive) firmly into the computer.

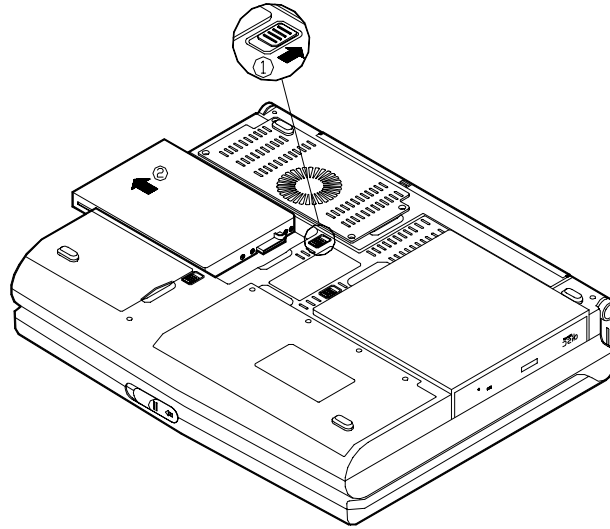

Figure 2-11

Using CD-ROM

The EUROCOM DeskNote computer comes standard with a removable 5.25" CD-ROM module. It is labeled drive D: and may be used as a boot device if properly set.

To insert a CD, press the **Eject Button** and place the CD into the **Disc Tray** with label-side facing up. Push the CD tray in and you are ready to start. The **Busy Indicator** will light up while data is being accessed or while an audio CD is playing. When the power is unexpectedly interrupted, insert an instrument such as a straightened paper clip into the **Emergency Eject Hole** to eject the tray (Figure 2-12).

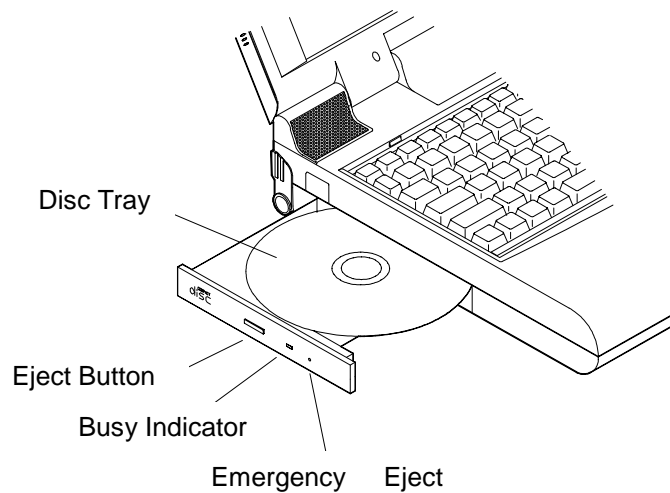

Figure 2-12

Removing CD-ROM Module

1. Turn the system power off.
2. Turn the computer over.
3. Locate the CD-ROM latch.
4. Press the latch in the direction indicated and take the CD-ROM module out of the computer (Figure 2-13).

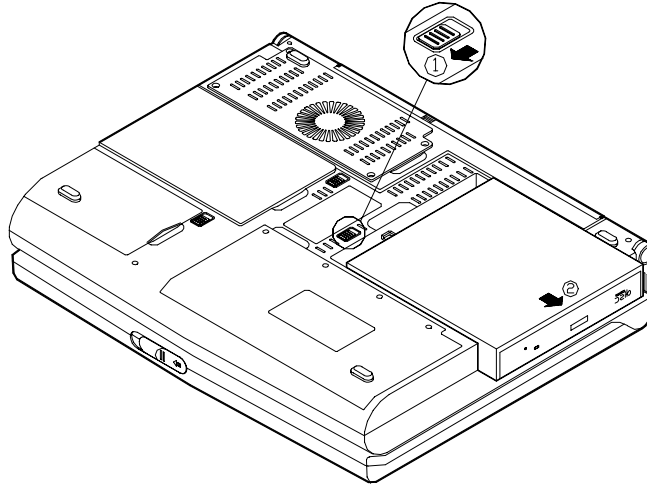

Figure 2-13

Loading Compact Discs

1. Turn on the power.
2. Press the CD-ROM eject button; the disc tray will pop out partially.
3. Pull the disc tray out.
4. Carefully load the CD into the disc tray with label-side facing up. Press it gently to ensure it fits into the place (Figure 2-14).
5. Push the tray into the computer.

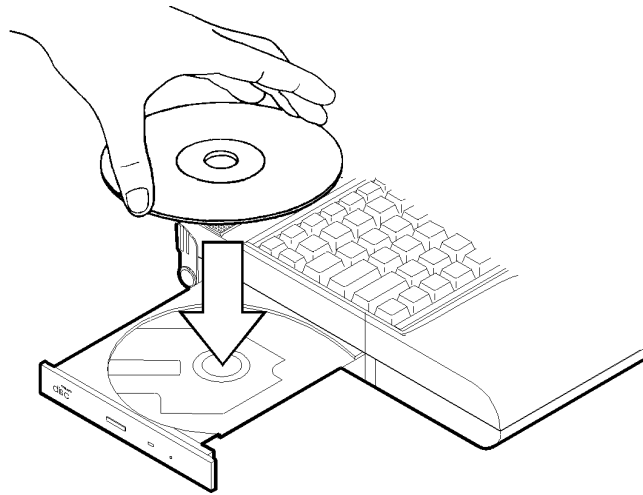

Figure 2-14

Handling of Compact Discs

Proper handling of your CDs will prevent them from being damaged and ensure the accessibility of data stored in them.

- Hold the CD by the edges; do not touch the surface of the disc.
- Use clean, soft, and dry cloth to remove dust or fingerprints.
- Do not use pen to write on the surface.
- Do not attach any paper or other materials to the surface of the disk.
- Do not store or place the CD in the high-temperature areas.
- Do not use benzene, thinners, or other cleaners to clean the CD.
- Do not bend the compact disc.
- Do not drop or subject the CDs to shock.

Using PC Card Sockets

The computer provides system expansion capabilities with two PC card sockets (previously referred to as PCMCIA). PC cards to be inserted can be LAN, fax/modem, communication devices, or expanded memory. Both sockets support 5V/3.3V 16-bit PC cards and 3.3V 32-bit PC cards (referred to as **CardBus**).

The PC card sockets on the right-side panel support one Type III card (equivalent to two Type II cards). The lower socket (socket A) is capable of **ZV (Zoomed Video)** (Figure 2-15).

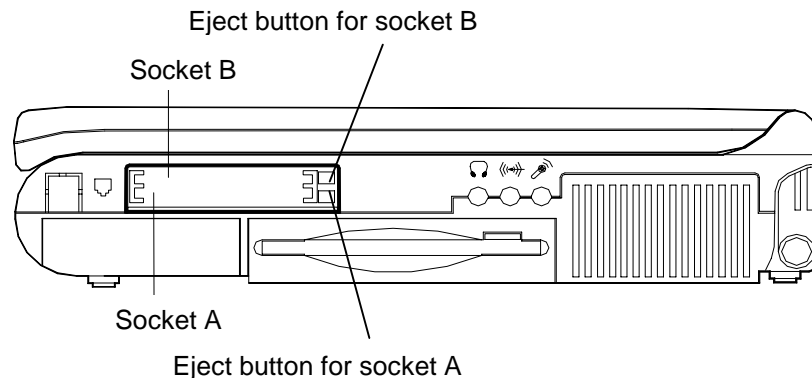

Figure 2-15

Note: There are three types of PC cards. Type 1 measures 3.3 mm thick; Type II 5.0 mm; and Type III 10.5 mm.

Inserting PC Cards

1. Open the access door (Figure 2-16).
2. Align the PC card with the slot and push it in firmly until it locks into the place (Figure 2-17).

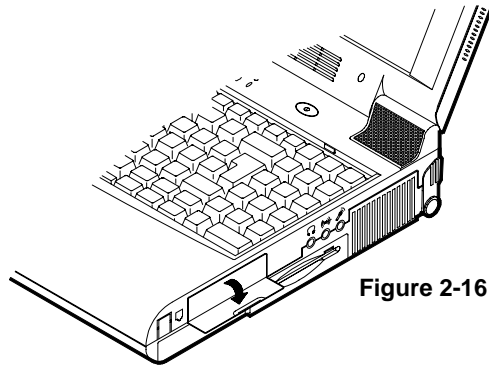
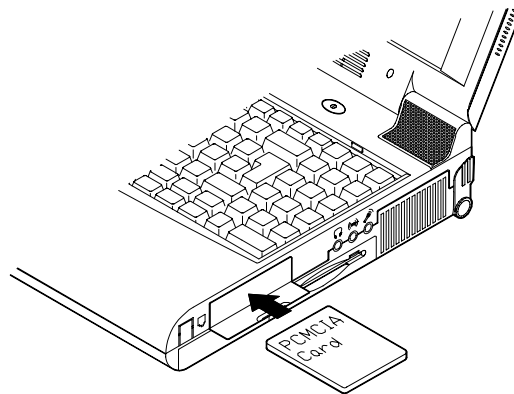

Figure 2-16

Figure 2-17



Removing PC Cards

To remove a PC card, press the appropriate eject button to eject the card from its slot. (Figure 2-15).

Using Hot Keys

Located on the bottom-left edge of the keyboard layout is a colored **Fn** key. The **Fn** key function allows you to change operational features instantly. When you use the following functions, press and hold the **Fn** key; then press the appropriate function key (Figure 2-18).

| Hot Keys | System Features |
|----------|---|
| Fn + F3 | Expand LCD display. |
| Fn + F6 | Toggle CRT/LCD/LCD+CRT/TV/CRT+TV. |
| Fn + F9 | Decrease LCD brightness. |
| Fn + F10 | Increase LCD brightness. |
| Fn + F11 | Decrease audio volume. |
| Fn + F12 | Increase audio volume. |
| Fn + Z | Turn audio mute on/off. |
| Fn + Esc | Put the system in a suspend state for power management. |

Windows 95 Special Keys

The keyboard provides two keys that have special functions in Windows 95:



This key has the same functions as the secondary mouse does.



This key activates the Windows 95 Start menu.

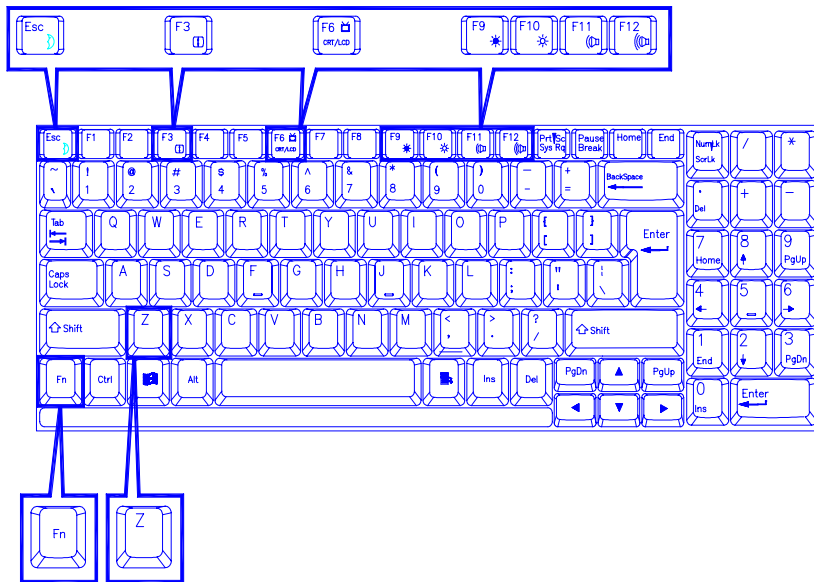

Figure 2-18

Using Numeric Keypad

The computer features a 102-key keyboard with an integrated numeric keypad for easy numeric data input (Figure 2-19).

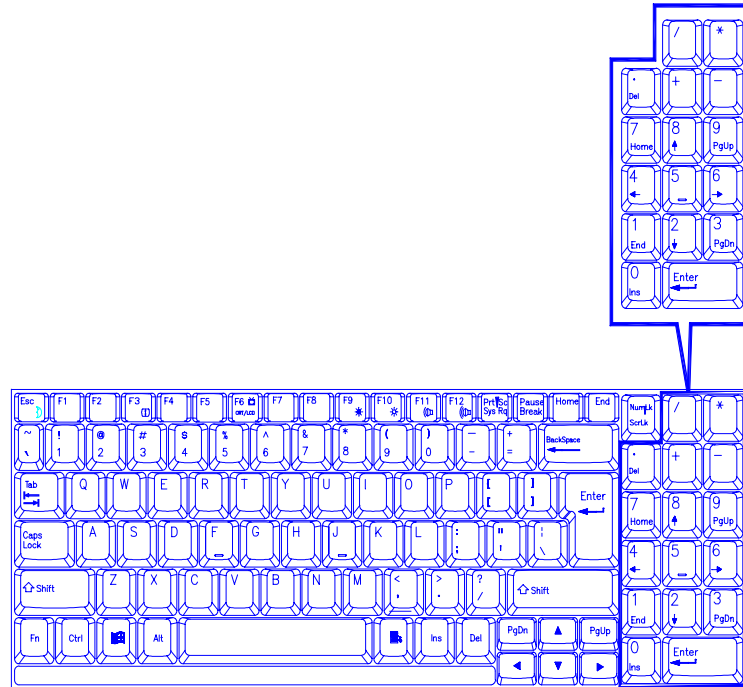

Figure 2-19



Using Power Management

The system provides you with various modes to manage its power consumption while maintaining system performance. Please refer to Chapter 3: BIOS Utilities, System Configuration Utility, Power Menu for more information.

Advanced Power Management (APM 1.2)

The system provides built-in Advanced Power Management (APM 1.2) support to reduce power consumption. APM function varies depending on the operation system you are using. **Some operation systems do not support APM, such as Windows NT, and therefore, cannot take advantage of the system's capabilities in this area.**

Global Standby

In Global Standby mode, the CPU clock will be stopped and most controllable peripheral devices will be power off. If the idle timer expires before any system activity is detected, the system will change from Standby mode into Suspend mode.

Hard Disk Standby

The system will turn off the computer's hard disk drive motor if it has not been accessed after a specified period of time. The motor will be turned back on if the system attempts to read or write data to it.

Suspend and Resume

When at extremely low power, you can enter suspend mode to save power. In suspend mode, all tasks are stopped and stored in memory to save power. The system features two levels of suspend mode: Powered-On-Suspend (POS) mode and Suspend-To-Disk (STD) mode.

Another useful feature is resume mode. This feature allows you to turn the computer's power off without exiting your software application. When you turn the power on again, you can resume work where you left off, because the screen display is restored as you left it. This saves time and battery power.

Caution: Do not enter suspend mode when you are

1. Accessing any of the disk drives, such as HDD, FDD or CD-ROM drives.
2. Using the audio features or playing back video.
3. Playing a DOS game.

Powered On Suspend (POS)

Of the suspend modes, Powered-On-Suspend saves the least amount of power. However, it takes the shortest time to return to full operation.

Resume from POS Mode

The system can resume from Powered-On-Suspend mode by:

- Alarm resume (month/day/hour/minute)
- Modem ring
- Pressing any keyboard key.
- Pressing the power button (if configured as Suspend/Resume function under SCU)
- Opening the display lid (only if the suspend mode is initiated by closing the display lid)

Suspend To Disk (STD)

Suspend to Disk is a 0-volt suspend mode for system power management. STD mode saves the maximum power but takes the longest time to return to full operation.

1. Use your operation system's FDISK program to delete all partitions of the hard disk if any already exist on the target drive.
2. Boot the system and run the 0VMAKFIL.EXE Utility to create the Suspend to Disk partition on the hard disk. The size of Suspend to Disk partition will be the installed DRAM (n) plus 8MB integrated video RAM.

:>0VMAKFIL -Pn

For example, if the system DRAM is 32MB, 0VMAKFIL will create a partition size of approximately 40MB.

:>0VMAKFIL -P32

Resume from STD Mode

The system will resume from Suspend-To-Disk mode by:

- Power back on
- Alarm resume (month/day/hour/minute)
- Opening the display lid (only if the suspend mode is initiated by closing the display lid)

Attaching Peripheral Devices

To extend the computer's functions, you can attach the following peripheral devices to the computer through the ports or jacks on the rear panel of computer.

Attaching a Security Lock

The security lock is equipped to protect your computer from being stolen. To install the security lock, wrap the cable around a desk or other immovable object, then insert the locking device into the connector (Figure 2-20).

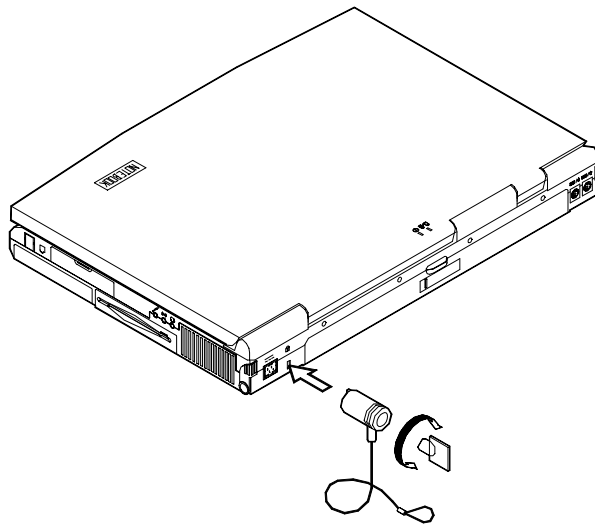

Figure 2-20

Attaching a Parallel Printer

You may connect any standard Centronics parallel printer to your computer through the parallel port.

1. Turn the system power off.
2. Connect the cable to the parallel port on the rear of the computer.
3. Tighten the screws that fasten the cable to the parallel port (Figure 2-21).
4. Insert the other end of the cable to the printer's connector. Fasten the cable's connector.
5. Turn on the printer and computer.

In addition, you also need to install the manufacturer-supplied driver for the printer. Refer to the device's user's guide for more information. If the connected printer supports EPP (Enhanced Parallel Port) or ECP (Extended Capabilities Port) mode, please enter System Configuration Utility (SCU) to configure the required setting.

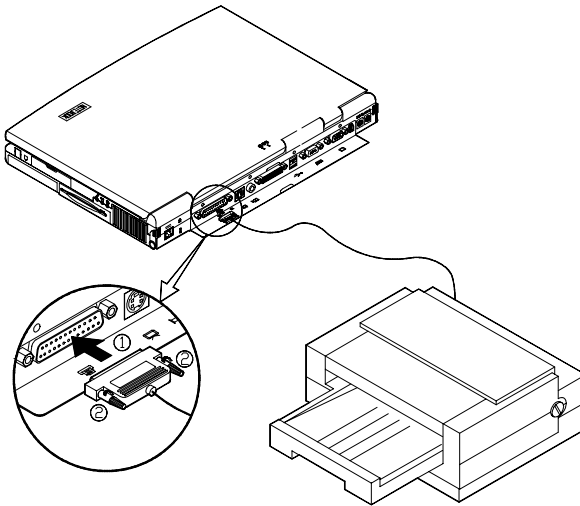

Figure 2-21

Attaching a TV Set

The S-Video jack on the rear panel of the computer is used for transmitting video signals to a TV set. You may need to select the video standard for video display. Enter the System Configuration Utility (SCU), Components Menu to specify the appropriate TV mode. Simultaneous display on external monitor (CRT) and TV is available. You can enter the SCU to select the appropriate parameters or use the **Fn + F6** keys (refer to Chapter 2, Using Hot Keys).

Attach the TV set as shown below (Figure 2-22).

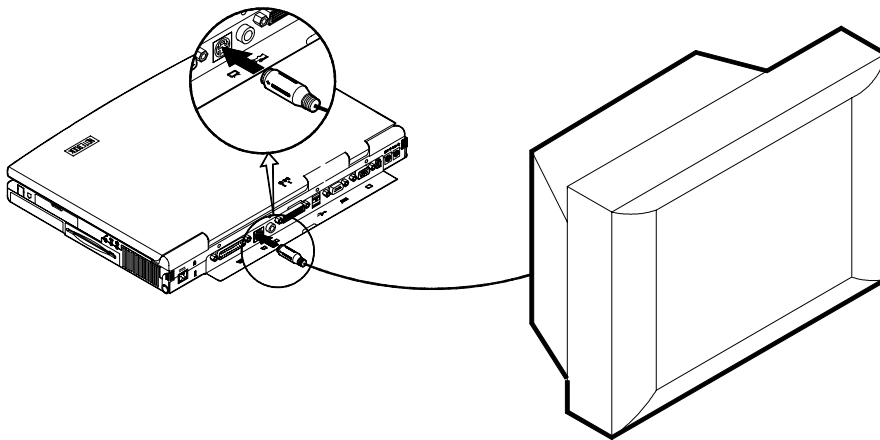

Figure 2-22

Attaching a Video Input Device

The RCA jack on the rear panel of the computer allows analog composite signal input from external video devices. Attach the device as shown below (Figure 2-23).

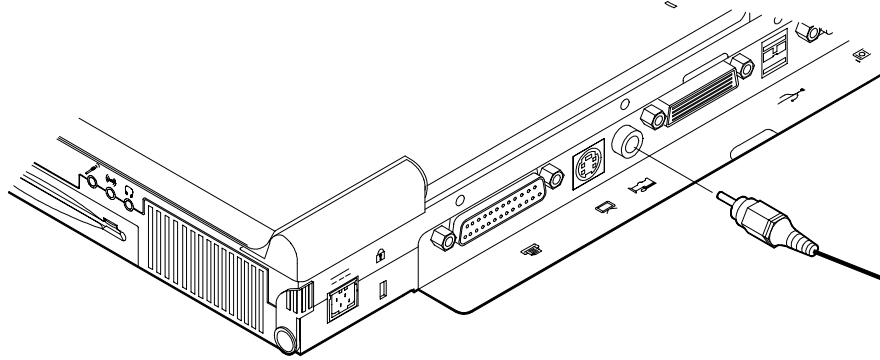

Figure 2-23

Attaching a USB-compatible Device

The computer provides dual USB ports for connection of a USB-compatible keyboard, mouse, or other devices. Attach the device as shown below (Figure 2-24).

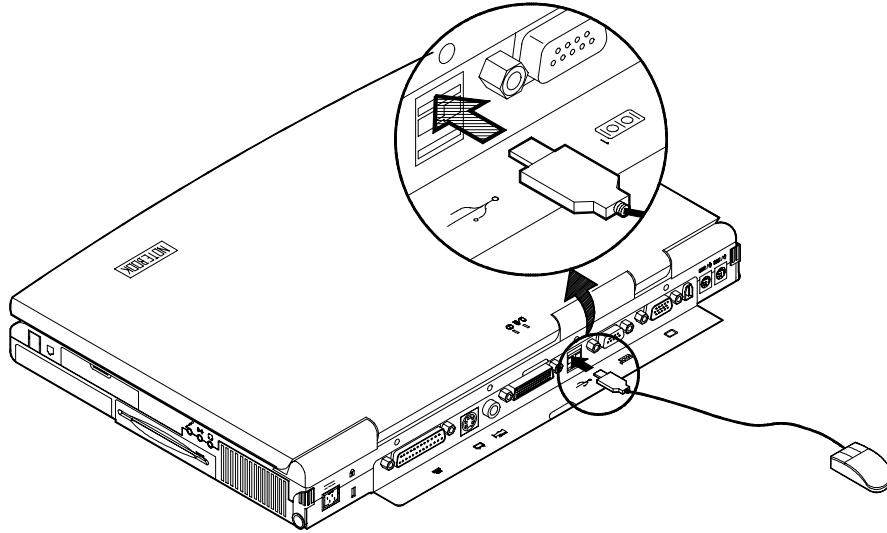

Figure 2-24

Attaching a Serial Mouse

The serial port features a 9-pin connector. You can connect any serial device such as a mouse to this port.

1. Turn the system power off.
2. Connect the cable to the serial port on the rear of the computer.
3. Tighten the screws that fasten the cable to the serial port (Figure 2-25).
4. Turn on the computer.

In addition, you may need to install the manufacturer-supplied driver for the serial mouse. Refer to the device's user's guide for more information.

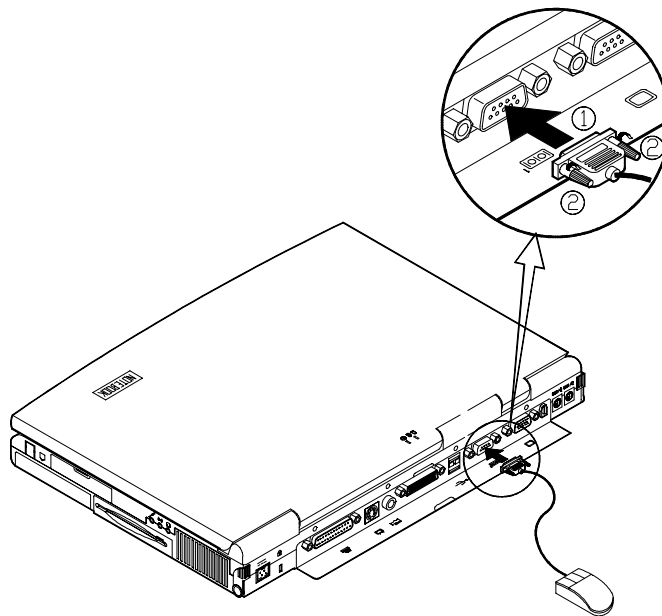

Figure 2-25

Attaching an External Monitor (CRT)

The computer is capable of displaying not only on the LCD, but also on the XGA compatible displays attached to the computer. Information can be displayed on both the LCD and the external monitor simultaneously. Enter the System Configuration Utility (SCU) to select the appropriate parameters or use the **Fn + F6** keys (refer to Chapter 2, Using Hot Keys).

1. Turn the system power off.
2. Connect the cable to the CRT port on the rear of the computer.
3. Tighten the screws that fasten the cable to the CRT port (Figure 2-26).
4. Insert the other end of the cable to the external monitor.
5. Turn on the computer.

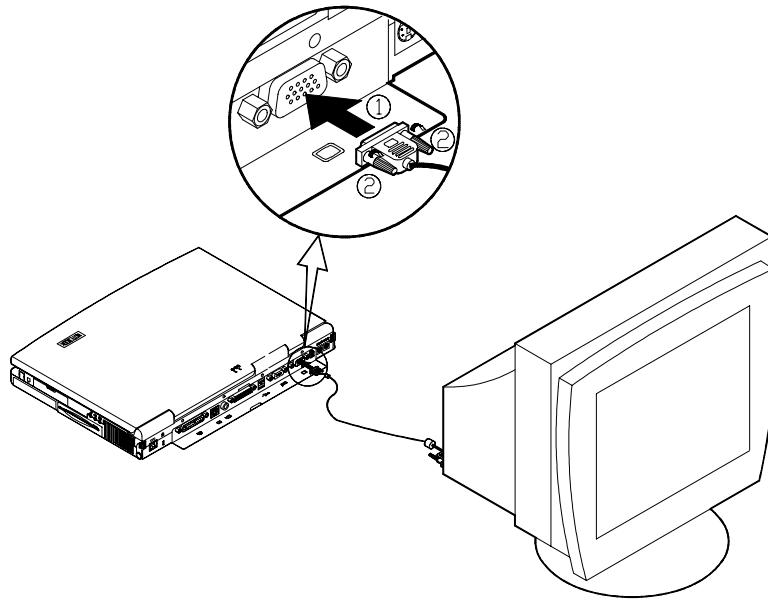

Figure 2-26

Attaching a PS/2 Keyboard or Mouse

The computer can be operated with a PS/2 keyboard or mouse attached by means of the PS/2 transfer cable. Attach the external keyboard or mouse as shown below (Figure 2-27).

Both PS/2 type ports on the rear panel of the computer can be used for the connection of a PS/2 keyboard and mouse.

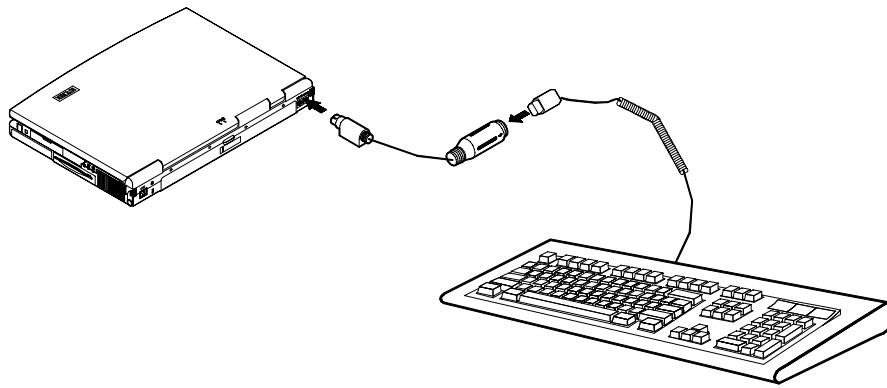

Figure 2-27

Attaching a Digital Camera

A digital camera can be connected to the computer through the 1394 port. However, not every type or brand of digital camera can be connected to the computer. Choose the camera that comes with a specially designed plug for 1394 port (Figure 2-28).

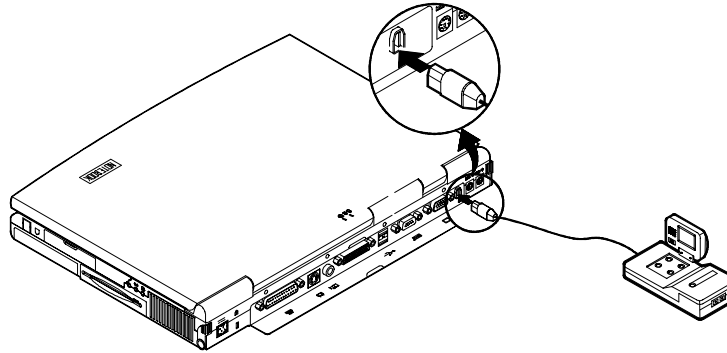

Figure 2-28

Chapter 3 : BIOS Utilities

This chapter provides you with the information of Power On Self-Test (POST) and shows you how to configure the system parameters using the System Configuration Utility (SCU).

- 📄 Power on Self Test (POST)
 - POST Message: Normal Operation
 - POST Message: Error Detected
- 📄 System Configuration Utility (SCU)
 - Information in the SCU
 - Initiating the SCU
 - Working with the Menu Bar of the SCU
 - Working with the Pull-Down Menu of the SCU
 - Features of the SCU
 - Startup Menu
 - Memory Menu
 - Disks Menu
 - Components Menu
 - Power Menu
 - Exit Menu

Power on Self Test (POST)

The system BIOS (Basic Input/Output System) performs a series of Power On Self-Test (POST) on system memory and key computer components every time the computer is turned on. If an error exists, the POST routine may halt execution (depending on the problem). If no error exists, the POST will initialize BIOS configuration, then boots the operating system.

POST Message: Normal Operation

You will see the following message if no error exists after the POST is performed.

```
SystemSoft MobilePRO BIOS Version 1.01 (2482-00)
Copyright 1983-1996 SystemSoft Corp. All Rights Reserved
```

```
233 MHz Pentium with MMX CPU
External Cache: 512KB installed
8 MB Video RAM
SystemSoft Plug-n-Play BIOS Ver.1.17.01
```

```
Base Memory      000640 Kb
Extended Memory  064512 Kb
Total Memory     065536 Kb
```

```
Auto Detecting IDE Devices[Done]
```

```
<CTRL-ALT-S> to enter System Configuration Utility
```

Note:

You may press the **Spacebar** key to skip the memory test.

POST Message: Error Detected

If an error is detected, you will see the following WARNING message. You may press **F1** key to continue, or press the **Ctrl-Alt-S** keys simultaneously to enter the System Configuration Utility.

SystemSoft MobilePRO BIOS Version 1.01 (2482-00)
Copyright 1983-1996 SystemSoft Corp. All Rights Reserved

233 MHz Pentium with MMX CPU
External Cache: 512KB installed
8 MB Video RAM
SystemSoft Plug-n-Play BIOS Ver.1.17.01

| | |
|-----------------|-----------|
| Base Memory | 000640 Kb |
| Extended Memory | 064512 Kb |
| Total Memory | 065536 Kb |

WARNING – HARD DISK CONTROLLER 1 FAILURE
Auto Detecting IDE Devices[Done]

<CTRL-ALT-S> to enter System Configuration Utility
Press F1 to Continue

System Configuration Utility

The System Configuration Utility (SCU) is a ROM-based configuration utility that displays the system's configuration status and provides users with a tool to set their system parameters. The settings are stored in non-volatile battery-backed CMOS RAM which saves the information even when the power is turned off, and retains it when the system is turned on again.

Information in the System Configuration Utility

The following shows the system settings that may be changed within the System Configuration Utility.

| Menu Bar Items | Pull-down Menu Items |
|-----------------------|---|
| Startup | Date and Time, Fast Boot, Boot Device, Display, Enable Battery Low Beep, Enable LCD Expand Mode, Enable Power On Beep, Boot Password, SCU Password. |
| Memory | Cache Systems. |
| Disks | Enable LS120/ZIP 100 Drive, Diskette Drives, IDE Settings. |
| Components | COM Ports, MODEM Port, LPT Port, PS/2 Mouse Port, Microsoft IntelliMouse Support, Keyboard Numlock, Keyboard Repeat, TV Mode, Video in Mode, ZV Port Enabled |
| Power | Enable Power Saving, Low Power Saving, Medium Power Saving, High Power Saving, Customize, Suspend Controls, Resume Timer, Enable MODEM Ring Resume, Enable Battery Low Suspend, Advance CPU Controls. |
| Exit | Save and Exit, Exit (No Save), Default Settings, Restore Settings, Version Info. |

Initiating the System Configuration Utility

The System Configuration Utility (SCU) can be accessed when pressing the **Ctrl**, **Alt**, and **S** keys simultaneously.

<CTRL-ALT-S> to enter System Configuration Utility

The above message only lasts seconds. If you miss it, the computer will initiate the boot process. You must reboot the system and try again within the time limit if you want to enter the System Configuration Utility.

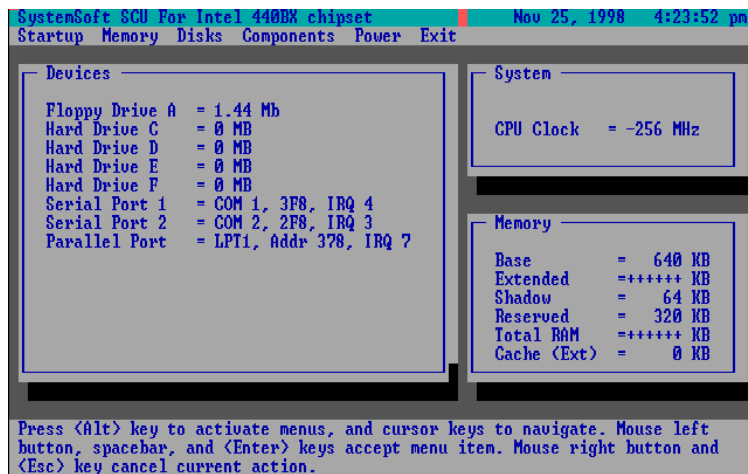

Figure 3-1
System Configuration Utility (SCU)

Working with the Menu Bar

After entering the SCU, you may use the following keys to work with the menu bar.

| Keys | Action | Description |
|--|-----------------------|---|
| Alt | Activate menus | Activate the System Configuration Utility. |
| Left arrow (←) | Select menu bar item. | Move to a menu bar item on the left. |
| Right arrow (→) | | Move to a menu bar item on the right. |
| The highlighted letter key | | Move to the corresponding menu bar item. |
| Mouse left button Spacebar Enter | Accept menu bar item | Enter the selected menu bar item to configure settings. |
| Mouse right button Esc | Cancel current action | Undo the current command. |

Working with the Pull-down Menu

When the desired menu bar item is highlighted, press the **Enter** key to enter the pull-down menu for values setting. You may use the following keys to work with the pull-down menu.

| Keys | Action | Description |
|--------------------------------|-----------------------------|---|
| Down arrow (↓) Up arrow (↑) | Select pull-down menu item. | Move to the next pull-down menu item. |
| The highlighted letter key | | Move to the previous pull-down menu item. |
| Tab | Select a control | Move to the corresponding pull-down menu item. |
| Tab | Select a control | Move between the options. |
| Down/Up arrows (↓)(↑) | Change values | Modify the settings. |
| Spacebar | Accept entries | Enable/disable the specified function. When a check mark (√) appears, the function is on. |
| Enter | | Choose <OK> from a list of options. |
| Esc | Reject entries | Undo the current setting. |
| Enter | | Choose <Cancel> from a list of options. |
| Alt | Activate accelerators | Initiate all the highlighted letters corresponding to their respective options. |
| Esc | Quit | Press the Esc key to close the pull-down menu. |

Features of the System Configuration Utility

Startup Menu

| Item | Setting/Option | Function |
|-------------------------|--------------------------------------|---|
| Date and Time | Day/Month/Year Hour/Minute/Second | Set the current date and time. |
| Fast Boot | Enable | Initialize and quickly boot the system in a few seconds by skipping certain diagnostic tests. |
| | Disable | Disable the above. |
| Boot Device | Diskette A | Specify where the system boots from. |
| | Hard Disk C | |
| | CD-ROM Drive | |
| Display | LCD | Activate the system's LCD panel. |
| | CRT | Activate an external monitor. |
| | LCD + CRT | Activate both the LCD and the CRT. |
| | TV | Activate an external TV. |
| | LCD + TV | Activate both the LCD and the TV. |
| | CRT + TV | Activate both the CRT and the TV. |
| | LCD + CRT + TV | Activate the LCD, CRT and TV. |
| Enable Battery Low Beep | Enable | The system emits a series of warning beeps sound when the battery power becomes low. |
| | Disable | Disable the above. |
| Enable LCD Expand Mode | Enable | Stretch the display to fill the entire viewing area of the LCD panel. |
| | Disable | Disable the above. |

| Item | Setting/Option | Function |
|----------------------|------------------------------|---|
| Enable Power On Beep | Enable | Enable or Disable Power On Beep. |
| | Disable | |
| Boot Password | Enter old Power-On Password | Set password for booting computer. Users are authorized to start the system after entering correct password. |
| | Enter new Power-On Password | |
| | Verify new Power-On Password | |
| | Enable Password to Power-On | |
| SCU Password | Enter old Setup Password | Set password for modifying SCU. Users are authorized to change the SCU setting after entering correct password. |
| | Enter new Setup Password | |
| | Verify new Setup Password | |
| | Enable Setup Password | |

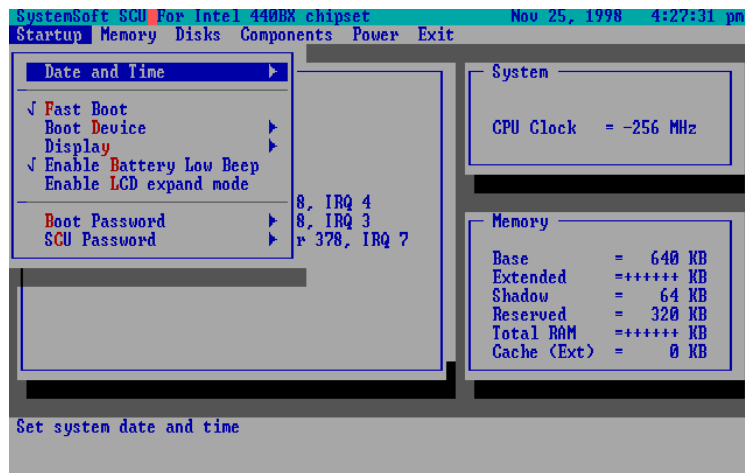

Figure 3-2
Startup Menu

Memory Menu

| Item | Setting/Option | Function | |
|---------------|----------------|---|--|
| Cache Systems | L1 Cache | Disabled | Disable the processor's internal cache. |
| | | Write Back | Enable the Processor's internal write-back cache. |
| | L2 Cache | Disabled | Disable the L2 cache controller. |
| | | Write Back | Enable the LS write-back cache. |
| | BIOS Shadow | Cached | The process of <i>shadowing</i> copies instructions from system BIOS into RAM to improve system performance. |
| | | Not Cached | Disable the above. |
| Video Shadow | Cached | The process of <i>shadowing</i> copies instructions from video BIOS into RAM to improve system performance. | |
| | Not Cached | Disable the above. | |

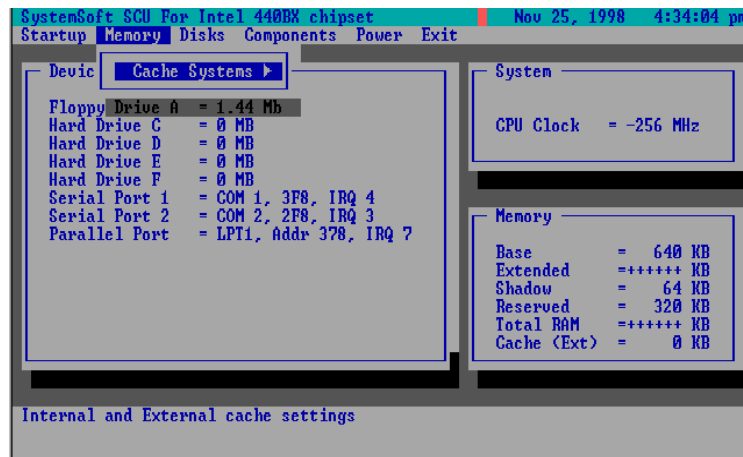

Figure 3-3
Memory Menu

Disks Menu

| Item | Setting/Option | | Function |
|------------------------|---------------------------------|---------------|---|
| Diskette Drives | Drive A | None | Specify the drive types for the diskette drive A. |
| | | 1.44 Mb | |
| | | 2.88 Mb | |
| IDE Settings | Primary HDD | Drive Enabled | Enable enhanced IDE settings. |
| | | PIO Mode | |
| | CD-ROM / DVD-ROM / 3rd HDD | Drive Enabled | |
| | | PIO Mode | |
| | LS120 /ZIP/ 2 nd HDD | Drive Enabled | |
| | | PIO Mode | |
| Enable LS120/ZIP Drive | Enable | | Enable the LS120 or ZIP drive. |
| | Disable | | Disable the LS 120 or ZIP drive. |

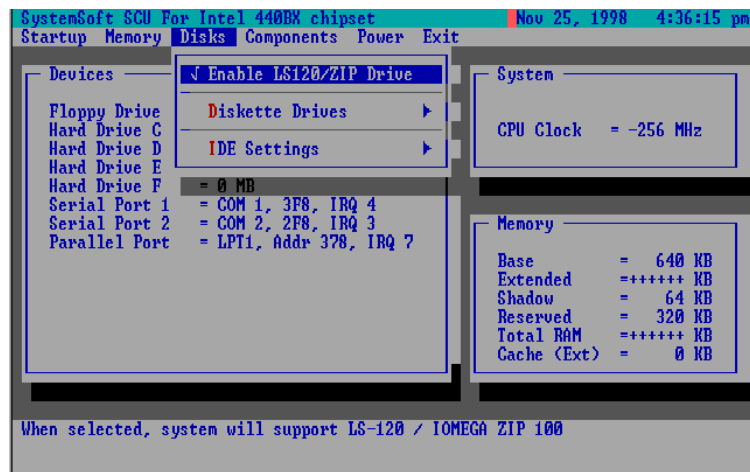

Figure 3-4
Disks Menu

Components Menu

| Item | Setting/Option | Function | |
|-------------------------|--------------------------|--|--|
| COM Ports | COM A I/O Settings | None | Specify the COM A configuration. (COM3 & COM4 Only for DOS mode and Non-PnP OS.) |
| | | COM1, 3F8, IRQ4 | |
| | | COM2, 2F8, IRQ3 | |
| | | COM3, 3E8, IRQ10 | |
| | | COM4, 2E8, IRQ11 | |
| | COM B I/O Settings | None | Specify the COM B configuration. (COM3 & COM4 Only for DOS mode and Non-PnP OS.) |
| | | COM1, 3F8, IRQ4 | |
| | | COM2, 2F8, IRQ3 | |
| | | COM3, 3E8, IRQ10 | |
| | | COM4, 2E8, IRQ11 | |
| | Mode Setting for COM B | Normal (16550) | Define the COM B hardware. |
| | | IrDA (HPSIR) | |
| | | ASK IR | |
| FAST IR | | | |
| DMA Setting for Fast IR | DMA 0 | Specify the Fast IR DMA configuration. | |
| | DMA 1 | | |
| | DMA 3 | | |
| LPT Port | Port Address | None | Specify the LPT port and IRQ configuration. |
| | | LPT1, Addr 378, IRQ7 | |
| | | LPT2, Addr 278, IRQ5 | |
| | | LPT3, Addr 3BC, IRQ7 | |
| | Port Definition | Standard AT (Centronics) | |
| | | Bi-directional (PS-2) | |
| | | Enhanced Parallel (EPP) | |
| | | Extended Capabilities (ECP) | |
| | DMA Setting For ECP Mode | DMA 1 | Specify the ECP DMA configuration. |
| | | DMA 3 | |
| EPP Type | EPP 1.7 | Specify the EPP type. | |
| | EPP 1.9 | | |

| Item | Setting/Option | | Function |
|--------------------------------|-----------------|---------|--|
| PS/2 Mouse Port | Enable | | Enable the system's trackpad or an external PS/2 mouse. |
| | Disable | | Disable the trackpad or PS/2 mouse if an external mouse is connected to COM A port. |
| Microsoft Intellimouse Support | Enable | | Support PS/2 mouse with the wheel button. |
| | Disable | | Do not support PS/2 mouse with the wheel button. |
| Keyboard Numlock | Enable | | Specify whether Num Lock is on or off at system boot time. |
| | Disable | | |
| Keyboard Repeat | Key Repeat Rate | 2 cps | Define the rate (characters per second) at which the keyboard repeats while a key is depressed. |
| | | 6 cps | |
| | | 10 cps | |
| | | 15 cps | |
| | | 20 cps | |
| | 30 cps | | |
| | Key Delay | 1/4 sec | Specify the amount of time (second) that will pass after a key is depressed before the key starts to repeat. |
| | | 1/2 sec | |
| 3/4 sec | | | |
| 1 sec | | | |
| TV Mode | NTSC | | Specify the TV mode selection |
| | PAL | | |
| | NTSC-Japan | | |
| Video in Mode | Disabled | | Disable or enable the video in mode. |
| | Enabled | | |
| ZV Port Enabled | Enable | | Enable or disable the ZV port. |
| | Disable | | |

| Item | Setting/Option | Function |
|------------|------------------|----------------------------------|
| Modem Port | None | Specify the Modem Port settings. |
| | Port 3E8, IRQ 11 | |
| | Port 2E8, IRQ 11 | |
| | Port 3F8, IRQ 11 | |
| | Port 3E8, IRQ 9 | |
| | Port 2E8, IRQ 9 | |
| | Port 3F8, IRQ 9 | |
| | Port 2F8, IRQ 9 | |
| | Port 2F8, IRQ 11 | |

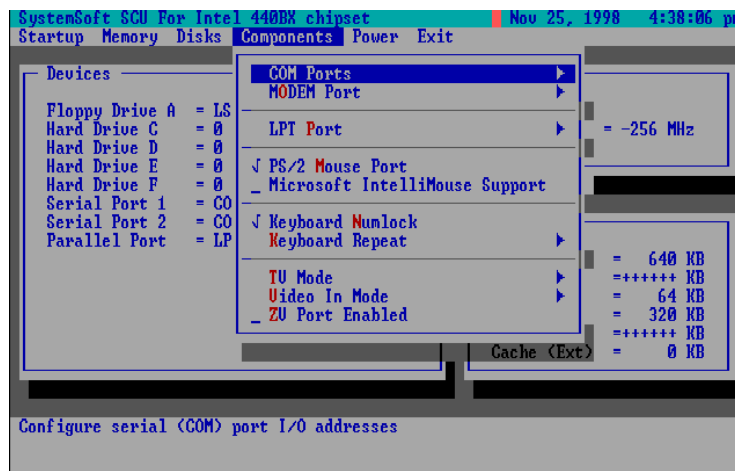

Figure 3-5
Components Menu

Power Menu

| Item | Setting/Option | | Function |
|---------------------|----------------|-----------|---|
| Enable Power Saving | Enable | | Enable/Disable all power saving features. |
| | Disable | | |
| Low Power Saving | Enable | | Enable/Disable the power saving to its lowest which results in max. performance but shortest battery life. |
| | Disable | | |
| Medium Power Saving | Enable | | Enable/Disable the power saving to its medium which results in both moderate performance and battery life. |
| | Disable | | |
| High Power Saving | Enable | | Enable/Disable the power saving to its highest which results in min. performance but longest battery life. |
| | Disable | | |
| Customize | Disk Standby | 5 sec | The hard disk will be put on standby if it is not accessed within the specified period. Hard disk power will be restored when the disk drive is accessed again. |
| | | 10 sec | |
| | | 15 sec | |
| | | 20 sec | |
| | | 30 sec | |
| | | Always on | |
| | Global Timeout | 1 min | The system power will be reduced if the system has been idle over the specified period. System power will be restored when any system activity is detected. |
| | | 2 min | |
| | | 4 min | |
| | | 6 min | |
| | | 8 min | |
| | | 12 min | |
| | | 16 min | |
| | | Always on | |

| Item | Setting/Option | | Function |
|------------------|------------------------------|---|---|
| Suspend Controls | Power Button Function | Power On/Off | The power button is switched to turn the system on or off. |
| | | Suspend/Resume | The power button acts as a suspend/resume button for switching the system between a working state and the suspend mode. Pressing the power button for more than four seconds will generate a power button over-ride event to switch the system from a working state to the Soft-Off state. |
| | Lid Switch Function | Suspend/Resume | Enter suspend mode or resume by closing or opening the display lid. |
| | | LCD Panel Off/On | Turn the panel power on or off by opening or closing the display lid. |
| | Suspend Type | Suspend to Disk | Specify the suspend mode for power management. |
| | | Powered on Suspend | |
| | Suspend Timeout | 1 min | If the system has been idle for the specified period, the system will enter user-defined suspend. |
| | | 5 min | |
| | | 10 min | |
| | | 20 min | |
| 30 min | | | |
| Resume Timer | Alarm | Enable | Resume the system from the configured suspend mode when resume alarm timer expires. |
| | | Disable | |
| | Resume Month/Day/Hour/Minute | The system will resume at the specified time (month, day, hour and minute). | |

| Item | Setting/Option | Function |
|----------------------------|-------------------------|--|
| Enable MODEM Ring Resume | Enable | Resume the system from STR or POS mode when a modem ring is detected (which modem should be connected to the serial port). |
| | Disable | Disable the above. |
| Enable Battery Low Suspend | Enable | Automatically suspend the system to disk upon a low battery condition. |
| | Disable | Disable the above. |
| Advance CPU Controls | Clock Control Mechanism | Specify the type of Processor Clock Control. |
| | | |
| | | Doze Mode |

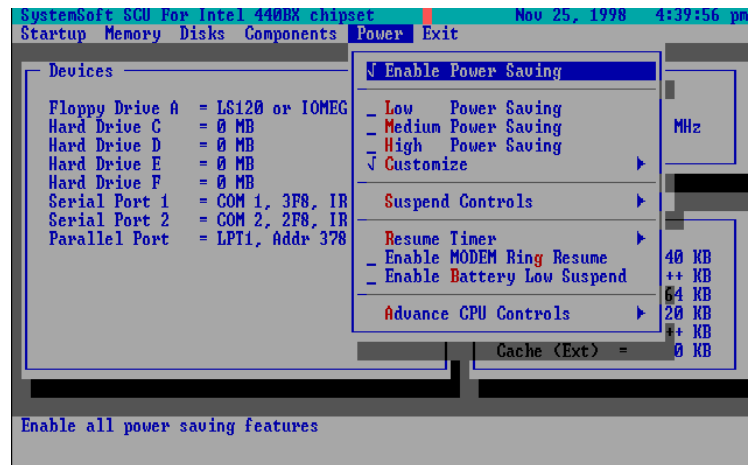

Figure 3-6
Power Menu

Exit Menu

| Item | Function |
|------------------|---|
| Save and Exit | Save the current settings and reboot the system. |
| Exit (No Save) | Exit without saving any current changes. |
| Default Settings | Restore the default settings (the original ones found in ROM). |
| Restore Settings | Restore the current setup settings to the original custom ones. |
| Version Info | Show current BIOS version information. |

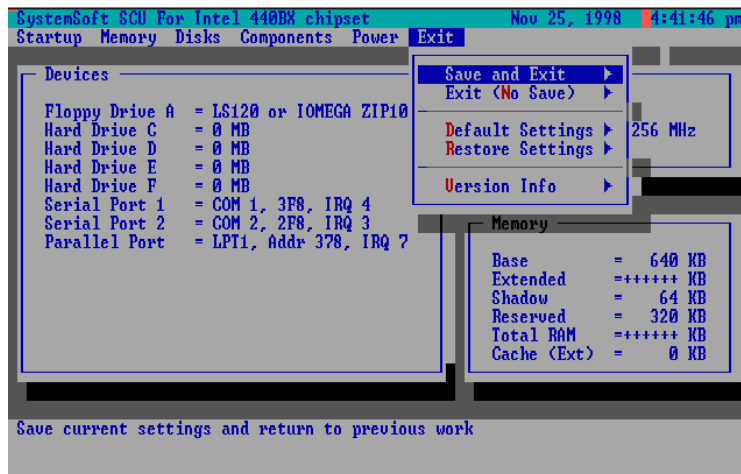

Figure 3-7
Exit Menu

Chapter 4 : Troubleshooting

Sometimes your computer has some problems. Before you consult the computer vendor, you can try to solve problems yourself. This chapter provides you with a list of some commonly experienced problems and their possible solutions.

| | | |
|---|---|-----------------------|
|  |  | Battery |
|  |  | Power |
|  |  | Hard Disk Drive |
|  |  | Floppy Disk Drive |
|  |  | Hardware Installation |
|  |  | LCD Panel |
|  |  | Memory Module |
|  |  | PC Card |
|  |  | Boot Password |
|  |  | Audio |
|  |  | CD |
|  |  | Printer |

Battery

Problem: *The battery pack can not be charged.*

Solution 1: The battery pack is exposed to excessively hot and cold environment. Let it restore to normal condition before you use it.

Solution 2: The power might be used up.

Problem: *The battery pack can not be charged and the charge indicator turns off.*

Solution 1: The battery has been fully charged.

Solution 2: The battery pack is exposed to excessively hot or cold environment. Let it restore to normal condition before you use it.

Solution 3: The power is used up.

Problem: *The beep sound is heard and the low-battery indicator turns on.*

Solution: The computer is in low-battery status. Please connect your computer with AC adapter, or press Fn + Esc key combination to enter suspend mode.

Problem: *The beep sound isn't heard whereas the low-battery indicator turns on, or the gauge indicates power is less than 10%.*

Solution: The computer is in low battery status. Please adjust the volume control and connect the computer with AC adapter.

Problem: *The actual battery operation time is shorter than expected.*

Solution 1: The battery is exposed to excessively high or low temperature. The ideal temperature for battery operation is between 50°F and 95°F (10°C and 35°C) whereas keeping is between 32°F and 113°F (0°C and 45°C).

Solution 2: The battery has released some power. Please recharge it.

Solution 3: The power management has been turned off.

Solution 4: Some peripheral device or PC card is consuming power. Turn off the unused device to save power.

Solution 5: The battery has been given a partial charge. When charging, always fully charge after fully discharge.

Power

Problem: *The computer can not boot when the battery pack is not inserted.*

Solution 1: The power cord is not correctly connected with AC adapter. Make sure the power cord is firmly plugged into grounded outlet and computer.

Solution 2: The grounded outlet is not in normal operation. Check the outlet's function or use other outlet.

Problem: *The system has automatically entered suspend mode.*

Solution 1: The system's temperature is too high. Let it cool before you use it.

Solution 2: The system has entered suspend mode after a specified period of time. Please press any key or touch the trackpad to wake up the computer.

Hard Disk Drive

Problem: *The message "Nonsystem disk" appears.*

Solution: The computer is trying to boot from the floppy including no software. Please take the floppy out and restart the computer.

Problem: *It needs a longer time to read the hard disk drive after restarting the computer.*

Solution 1: The data saved on hard disk drive may be lost. Please operate the "disk defragmenter" to check the lost unit.

Solution 2: As in low battery status, the computer is waking up from the suspend mode.

Floppy Disk Drive

- Problem:** *The floppy disk drive can not write data to disk.*
- Solution 1:** The floppy is not formatted.
- Solution 2:** The floppy is write-protected. Please cancel the protection.
- Solution 3:** The data is written to incorrect disk drive.
- Solution 4:** The space left on disk is not enough. Please use a new disk or delete the unneeded data.
-
- Problem:** *The disk drive can not read the disk.*
- Solution 1:** The disk is not formatted.
- Solution 2:** The disk is damaged.
- Solution 3:** An incorrect disk type is used.

Hardware Installation

- Problem:** *The computer can not recognize the device as part of the system.*
- Solution 1:** The power switch of new device is not turned on. Please turn on the power switch, then restart the computer.
- Solution 2:** You do not rearrange the computer after the device is installed.
- Solution 3:** The power cord or the connector between device and computer is plugged out. Please make sure the device is firmly connected with the computer.
- Solution 4:** You do not follow the system configuration as the computer suggested. Please follow the suggestion.

LCD Panel

Problem: *The font is too dark.*

Solution: The brightness or contrast is not correctly set. Please press Fn+F7 or Fn+F8 key combination (only limited to DSTN panel) to adjust the contrast control, and use Fn+F9 or Fn+F10 to adjust the brightness control.

Problem: *The screen is blank.*

Solution 1: The panel blank application might be set.

Solution 2: The system operates the screen saver after a specified period of time. Please press any key or touch the trackpad.

Solution 3: The brightness or contrast needs to be adjusted. Please press Fn+F7 or Fn+F8 key combination (only limited to DSTN panel) to adjust the contrast control, and use Fn+F9 or Fn+F10 to adjust the brightness control.

Solution 4: The system has entered suspend mode. Please press any key or touch the trackpad to wake up the computer.

Problem: *The LCD panel displays incorrect font or blinks when the computer is connected with an external monitor.*

Solution: The resolution you use for the monitor exceeds that the LCD panel can support whereas you have switched to the LCD panel. Please restart the computer.

Memory Module

Problem: *The computer can not boot.*

Solution: The incorrect type of memory module is installed.

Problem: *The memory capacity is not enough.*

Solution: The memory is not correctly configured for the application.

Problem: *The detected memory capacity is not correct.*

Solution: Some memory module is not correctly installed or not compatible with your computer.

Problem: *The message “out of memory” is displayed.*

Solution: The memory configuration is not correctly set or the memory is not enough to run the application.

Problem: *The message “insufficient memory” is displayed.*

Solution: The application can not be operated as the memory is used up.

PC Card

Problem: *The PC card can not be configured.*

Solution: The PC card is not supported.

Problem: *The system can not recognize the PC card.*

Solution 1: The PC card is not inserted into the socket or reversely inserted.

Solution 2: The PC card driver is not installed.

Solution 3: The PC card or card driver is not compatible with the computer.

Problem: *The beep sound is not heard while the PC card is inserted.*

Solution: The beep sound control is closed.

Boot Password

Problem: *You forget the boot password.*

Solution: While forgetting the password, you must unpack the computer and delete the memory. Please ask the vendor for help

Audio

Problem: *The audio speaker can not be heard.*

Solution: The volume might be set too low. Please check your volume control.

Problem: *The volume is too high (or too low).*

Solution: The volume is not correctly set. Please check your volume control.

Problem: *The headphone can not be heard.*

Solution 1: The volume is not correctly set. Please check the volume control.

Solution 2: The volume source is not chosen.

Solution 3: The headphone is plugged into the wrong jack.

CD-ROM

Problem: *The compact disk can not be exited.*

Solution: The compact disk is not correctly placed in the tray.

Problem: *The compact disk can not be read.*

Solution 1: The compact disk is not correctly placed in the tray.

Solution 2: The compact disk is dirty. Please clean it with a CD-ROM cleaner kit.

Problem: *The musical compact disk can be read while the data disk can not.*

Solution: The compact disk hardware for reading data needs to be checked.

Problem: *All compact disks can not be read.*

Solution 1: The Windows system can not recognize the CD-ROM drive or the CD-ROM drive is not compatible with other devices.

Solution 2: The compact disk is dirty. Please clean it with a CD-ROM cleaner kit.

Solution 3: The compact disk hardware for reading data needs to be checked.

Printer

Problem: *The printer can not be set up.*

Solution: The printer power cord is not plugged into or the connector is not correctly connected.

Problem: *The printer can not work.*

Solution 1: The printer is not power on. Please turn on the printer.

Solution 2: The printer is not in “connected” status. Please set the printer in “connected” status.

Solution 3: The printer paper is used up. Please add the paper.

Solution 4: The printer driver is not installed or correctly chosen. Please check the system.

Solution 5: The printer for network is not connected with the network.

Problem: *The printer prints incorrect data.*

Solution 1: The printer driver is not installed or correctly chosen.

Solution 2: The printer power cord is not plugged into or the connector is not correctly connected.





ATI DVD Play (option)

Problem: *When the DVD station is playing, pressing (Fn) hot keys quickly at the same time, the DVD station will stop running in the normal Windows system.*

Solution: Please avoid pressing the Hot keys quickly and continuously. For example, when use the Fn key, stopping seconds each time before pressing again. Or go to Windows 95/98, click the icon of volume at the right-bottom corner the voice volume.

Chapter 5 : Installing Drivers

This chapter provides users the step-by-step instructions of installing device drivers and utilities. Information has been designed to suit for the users who has the basic computer knowledge. However, the inexperienced users also can get good help from the instruction.

-  Installing Windows 95
-  Installing Windows 98
-  Installing Drivers in Windows 95
-  Installing Drivers in Windows NT4.0
-  Installing Drivers in Windows 98

Installing Windows 95

Preparation for installing Windows 95:

1. Use a bootable floppy disk to start the system.
2. Run FDISK utility from DOS to create a bootable partition.
(See DOS manual for the operation detail.)
3. Format hard disk. Follow the command "Format C:/S" to create a bootable hard disk and make the boot system file.
(C:/S copies system files to the formatted disk)
4. Run CDINST.COM program from the "CD-ROM Drive Installation Diskette" that will help you to install CD-ROM driver device automatically. See the driver manual for detail.
5. Restart the system.

1. Start DOS.
2. Insert the Windows 95 CD-ROM.
3. Go to the "setup" directory, type "setup", then press [Enter].
4. After the Windows 95 setup program performs a routine check on your system, press [enter] to continue.
5. When the "Welcome to Windows 95 Setup" screen appears, click "Continue".
6. Click "Yes" on the "License Agreement" screen.
7. Click "Next" to select "Collecting Information About your PC".
8. Click "Next" to select the default of "C:\Windows", or enter a different directory.
9. On the screen of "Setup Options", select "Typical", then click "Next".
10. On the screen of "Certificate of Authenticity", enter the Product Identification Number, then click "Next".
11. On the screen of "User Information", enter your name and company, then click "Next".
12. Select "Install The Most Common Components (recommended)", then click "Next".
13. On the screen of "Startup Disk", insert a blank diskette into the A drive to create a startup diskette.
14. The Setup Wizard is now copying files. After the copying is finished,

remove the disk, then click "OK".

15. Click "Next" to start copying Windows 95 files to your computer.
16. Click "Finish" to restart Windows 95.
17. On the screen of "Set Up a Printer", click "Cancel".

Note:

Do not install a printer at this time. You will not be able to access the Windows 95 Installation CD until you reboot.

18. Click "OK" to restart the computer.

Installing Windows 98

1. Start DOS.
2. Insert the Windows 98 CD-ROM.
3. Type "setup", then press [Enter].
4. Follow the instructions on the screen and choose the recommended option.
5. The Windows 98 setup program will check the hard disk drive automatically.
6. When the setup initializes, click "Continue".
7. Choose "License Agreement" to agree the contrast.
8. Click "Next" to type the product ID number.
9. Click "Next" . The program will automatically check the system.
10. Choose the directory for your computer. Select the path of "C:\Windows", or type another path.
11. For reinstallation, choose "Yes" (recommended) to keep the files.
12. Select your location.
13. To create a Win98 Startup disk, insert a floppy disk into drive A. To create the startup disk later, choose "cancel".
14. Press "Next". The program will copy files to your computer's hard disk.
15. At the same time, the screen will show the Win98 concerned information and the setup items one by one.
16. After the automotive setup stops, restart the computer.

Installing Drivers in Windows 95

Step 1: Installing USB Driver

- Download “USB supplement path update file” from Microsoft and Intel web site.
- Run “USB supplement path” to install the driver.

Step 2: Installing TXPATCH Driver

- Locate the driver “[TXPATCH] Intel 82371xb.inf TX” from the CD-ROM.
- Run “setup.exe”.
- Follow the instruction to finish the installation.
- Restart the system.

Step 3: Installing VGA Driver

- Double click “Start”.
- Select “Run”.
- Open the path “D:\WIN9X\setup.exe”.
- Run “setup.exe” to finish the installation.

Note:

If ATI VGA driver has existed in WIN95 system, click “Start”, select “Run”, open the path “atiinst-clean”, and then double-click “OK” to finish installation.

Step 4: Installing Audio Driver (1978S M2E)

- Double click "Start".
- Select "Setting".
- Click "Control Panel"/"System"/"Device Manager".
- Select "Other devices".
- Remove "Unknown Device".
- Click "OK", then restart the system.
- After entering into WIN95 system, the program will automatically go to the "Add New Hardware Wizard" (PCI Multimedia Audio Device).
- Click "next"/"Other locations".
- Click "Browse" to locate the audio driver from the CD-ROM. (The path is :\\Audio\\WIN95.)
- Click "Ok".
- Click "Finish" to set up the first audio driver.

Step 5: Installing PCMCIA driver

- Double click "Start".
- Select "Setting".
- Click "Control Panel"/"system"/"Device Manager".
- Select "Other devices".
- Remove "PCI CardBus Bridge", and then click "OK".
- Open "Control Panel".
- Select "Add New Hardware".
- Click "Add PCMCIA socket".
- Locate the file "pcmcia.inf" from the disk or CD-ROM.
- Select "PCI-1225 CardBus" from "Texas Instrument".
- Click "next"/"next"/"Finish".
- Before restarting the system, copy the file "PCMCIA.inf" to "C:\\windows\\inf".

Note:

Copy "cbss.vxd", "pccard.vxd" & "pci.vxd" to c:\\windows\\system.

Step 6: Installing Video-in Driver

- Boot the system, press Ctrl + Alt + S to enter SCU system.
- Select “Components”.
- Enable “Video In Mode”.
- Under Windows 95, double click “Start”.
- Select “Run”.
- Open the path “D:\video-in\setup.exe”.
- Run “setup.exe” to finish the installation.

Step 7: Installing ATI DVD Play Driver (Option)

Note:

Make sure that you have already successfully installed the VGA Driver, Audio Driver and DirectX5 or DirectX6 beforehand.

- Boot the system; press Ctrl+Alt+S keys to enter SCU. Select [Power] menu. Enable [Low Power Saving], or select [Advance CPU control] to set [Full Speed]. (If the clock speed of the Intel Pentium II is above 366MHz/400MHz or if your DVD runs smoothly, you can skip this step).
- From the Windows 95/98 taskbar, click [Start] button; select [Settings], [Control Panel], and then click [System]. Click the tap [Device Manager]; select [CDROM], and click the item including the type of [DVD-ROM], Click the tap [Setting]; and then enable [DMA] check box.
- Insert the CD of ATI DVD Play application and the program will automatically run the installation until finished. Otherwise, click [Start] button from the Windows 95/98 taskbar. Select [Run]. Type [D:\Atiplay\setup.exe] and click OK to finish the installation.

Step 8: Using Infrared Wireless Communication

- Please refer to the readme file under the FIR directory.

Installing Drivers in Windows NT 4.0

Note:

After installing Windows NT4.0, please install Service Pack3 to enhance the function. Download the latest Service Pack3 version from the Microsoft web site.

Step 1: Installing VGA Driver

- Double click "Start".
- Select "Setting".
- Click "Control Panel".
- Select "Display".
- Click "Setting".
- Select "Display Type", and then select "Change".
- Click "Have Disk".
- Select "Browse" to specify the location.
- Open the path "D:\VGA\NT4.0".
- Click "OK". (All appropriate files are then copied to the hard disk.)
- Restart NT4.0 system.

Step 2: Installing Audio Driver (1978S M2E)

- Double click "Start".
- Select "Setting".
- Click "Control Panel".
- Select "Multimedia", and then select "Devices".
- Click "Add".
- Select "OK".
- Restart NT 4.0 system.

Installing Drivers in Windows 98

Step 1: Installing VGA Driver

- Double click "Start".
- Select "Run".
- Open the path "D:\WIN9X\setup.exe".
- Run "setup.exe" to finish installation.

Note:

When ATI VGA driver has existed in WIN95 system, click "Start", select "Run", open the path "atiinst-clean", and then double-click "OK" to finish installation.

Step 2: Installing Audio Driver (1978S M2E)

- Double click "Start".
- Select "Setting".
- Click "Control Panel".
- Select "system".
- Click "Device Manager".
- Select "Other devices".
- Remove "PCI Multimedia Audio Device".
- Click "OK", then restart the system.
- After entering into WIN98 system. The program will automatically go to the "Add New Hardware Wizard" (PCI Multimedia Audio Device).
- Click "next".
- Click "Browse" to specify the location.
- Open the path "D:\audio\Win95".
- Click "next", and then click "Finish" to set up the first audio driver.

Step 3: Installing PCMCIA Driver

- Click “Start”/”Control Panel”/”System”.
- Remove PCMCIA.
- Delete the two sub-directories [Generic CardBus Controller].
- Switch to DOS. Copy the file [PCMCIA.inf] to the directory [C:\windows\inf].
- Restart Win98 system.

Step 4: Installing Video-in Driver

- Boot the system. Press Ctrl+Alt+S to enter the SCU system.
- Select “Components”, and enable “Video In Mode”.
- Go to WIN98 system, double click “Start”.
- Select “Run”.
- Open the path “D:\video-in\setup.exe”.
- Run “Setup.exe” to finish the installation.

Step 5: Installing ATI DVD Play Driver (Option)

Note:

Make sure that you have already successfully installed the VGA Driver, Audio Driver and DirectX5 or DirectX6 beforehand.

- Boot the system; press Ctrl+Alt+S keys to enter SCU. Select [Power] menu. Enable [Low Power Saving], or select [Advance CPU control] to set [Full Speed]. (If the clock speed of the Intel Pentium II is above 366MHz/400MHz or if your DVD runs smoothly, you can skip this step).
- From the Windows 95/98 taskbar, click [Start] button; select [Settings], [Control Panel], and then click [System]. Click the tap [Device Manager]; select [CDROM], and click the item including the type of [DVD-ROM], Click the tap [Setting]; and then enable the [DMA] check box.
- Insert the CD of ATI DVD Play application and the program will automatically run the installation until finished. Otherwise, click [Start] button from the Windows 95/98 taskbar. Select [Run]. Type [D:\Atiplay\setup.exe] and click OK to finish the installation.

Appendix A: Specifications

The following are the features and specifications of the EUROCOM DeskNote computer.

-  **Processor EUROCOM 8500P DeskNote™**
 - 233/266/300/333/366/400 MHz Mobile Pentium II processors
 - Intel Mobile Module Connector II Structure (MMC2)
 - 66 MHz CPU Bus Clock

-  **Processor EUROCOM 8500P3 DeskNote™**
 - 450/500/550/600 MHz Mobile Pentium II processors
 - Intel Mobile Module Connector II Structure (MMC2)
 - 100 MHz CPU Bus Clock

-  **Processor EUROCOM 8500C DeskNote™**
 - 366/400/433/466 MHz Intel Celeron™
 - Intel Socket 370 Connector Structure
 - 66 MHz CPU Bus Clock

-  **Memory EUROCOM 8500P DeskNote™**
 - 3.3V power supply
 - Supports EDO/SDRAM
 - 32MB expandable up to 384MB
 - *32/64/128MB 144-pin SODIMM RAM modules (optional)*

-  **Memory EUROCOM 8500P3 DeskNote™**
 - 3.3V power supply
 - Supports PC-100 SDRAM
 - 32MB expandable up to 256MB
 - *32/64/128MB 144-pin SODIMM RAM modules (optional)*

-  **Memory EUROCOM 8500C DeskNote™**
 - 3.3V power supply
 - Supports EDO/SDRAM
 - 32 MB expandable up to 384MB
 - *32/64/128MB 144-pin SODIMM RAM modules (optional)*



System BIOS

- 256KB Flash ROM
- Plug and Play 1.0a



Display

- 15.1"/15.0" TFT XGA LCD panel
- 8MB display memory SGRAM type (100MHz)
- Support VPM 1.10 (Zoomed Video Port)
- DVD S-Video TV out
- Tri-view™ for a triple, TV, CRT & LCD.



Storage

- 3.5" FDD
- 12.7mm(h) LS-120MB floppy drive
- 15mm(h) IO Mega 100MB ZIP drive
- 2.5" hard disk drive (12.7 or 17mm high)
- 2.5" (12.7mm high) or 3.0" (12.5mm high) or 2.5" (17mm high) secondary hard disk drive
- DVD-ROM/CD-ROM (24X speed)



Audio

- Sound-Blaster Pro™ version 3.01 compatible
- 3D stereo sound system
- Stereo full duplex support
- MPEG-2 module
- Built-in microphone
- Built-in 2 watts speakers x 2



PC Card Sockets

- Support CardBus (PC Card95)
- Support Zoom Video Port (Socket A)
- Two Type II PC cards or one Type III PC card



Input/Output

- Built-in trackpad (PS/2)
- Dual USB ports
- S-video jack for TV output
- 120-pin expansion port
- RCA jack for video input
- External monitor (CRT) port
- Serial port
- Parallel port
- Dual PS/2 type ports
- Speaker-out jack
- Line-in jack
- Microphone-in jack
- IEEE1394 Port



Communication

- Wireless Infrared transfer IrDA 1.1
- 56K DSVD ISA Plug & Play Modem (option)



Power Management

- APM v1.2
- Soft Off
- CPU over temperature protection
- Suspend and resume



Power

- AC input: 100~240V, 47~63Hz
- Lithium-Ion Battery/Lithium-Ion Smart Battery



Size & Weight

- 358mm(w)x280mm(d)x50mm(h)
- 4.2kg (with Lithium-Ion battery)



Keyboard

- 102 keys Win95 keyboard include numeric keypad.



BIOS

- One 256KB Flash ROM.
- Systemsoft BIOS with Smart Battery, Plug and Play, ACPI.

Thank you for purchasing your Eurocom 8500 DeskNote™