

***Model 6X00***  
***Preliminary Service Manual***

*November 1996*

## **Notice**

Updating or revising this manual or making any changes to the information herein will be initiated when the company deems it necessary. The company reserves the right to take the above-mentioned actions and is under no obligation to notify any person of such actions in advance or afterwards.

1996

## **Trademarks**

MS-DOS, Microsoft Windows, and Microsoft Mouse are registered trademarks of Microsoft Corporation.

IBM PC, OS/2, PS/2, EGA, and VGA are registered trademarks of International Business Machines, Inc.

Intel, Pentium are trademarks of Intel Corporation.

SystemSoft is a registered trademark of SystemSoft Corp.

Sound Blaster Pro is a trademark of Creative Labs, Inc.

Duracell is a registered trademark of Duracell Inc.

Photo CD is a trademark of Eastman Kodak Company.

Other brand and product names are trademarks and/or registered trademarks of their respective companies.

# *Table of Content*

## **Chapter 1: Introduction**

Overview .....	1
Specifications.....	2
LED Indicators.....	3
Power Switch Button.....	3
Microphone 3	
System Status LCD Bar .....	4
Top-Front View .....	6
LCD Panel.....	6
System Status LCD Bar .....	6
Dual Stereo Speakers.....	6
Trackpad Pointing Device .....	6
Windows 95 Keyboard.....	6
Right View .....	8
Right-Side Stand.....	8
Microphone-in Jack.....	8
Line-in Jack.....	8
Headphone Jack.....	8
Infrared .....	8
PC Card Type III Expansion Slot.....	8
CD-ROM Drive.....	8
Ventilation .....	8
Rear View.....	10
DC-in Socket.....	10
Serial Port.....	10
Expansion Port.....	10
RCA Jack .....	10
External Monitor (CRT) Port.....	10
MIDI/Game Port.....	10
Parallel Port.....	10
External Keyboard or PS/2 Mouse Port.....	10
Left View .....	12
Left-Side Stand.....	12
Battery Latch .....	12
PC Card Type II Expansion Slot.....	12
2.5" Hard Disk Drive .....	12
3.5" Floppy Disk Drive.....	12
Internal Battery Pack.....	12
Power.....	14
AC Power .....	14
Internal Battery Power .....	15
Duracell Smart Battery at Retails .....	16
Second Battery Power (Option).....	17
Duracell Smart Battery at Retails .....	18
Operation .....	19
Hardware Configuration .....	19

CPU .....	19
Speed of CPU.....	19
Power of CPU.....	19
MPEG Accelerator Card (Option) .....	19
RAM Configuration .....	21
TV Output .....	22
The Keyboard.....	24
System Function Key.....	24
Cursor Control Keys .....	24
Embedded Numeric Keypad .....	25
Hot Keys.....	26
Expanded Display Mode.....	26
Display Type.....	26
Contrast Control.....	26
Brightness Control .....	26
Volume Control .....	26
Contrast/Brightness Saved.....	26
Suspend Mode .....	26
New Keys for Windows 95 .....	27
Application Key .....	27
Windows Keys .....	27
Storage Disks 28	
3.5" Floppy Drive.....	29
2.5" Hard Disk Drive .....	31
5.25" CD-ROM Drive .....	33
PC Cards Slots .....	34
LCD Panel.....	36
Power Management.....	37
Standby Mode.....	37
Suspend Mode .....	37
Suspend to Memory .....	37
Suspend to Disk.....	37
System Resume.....	38
Resume from Suspend-to-Memory Mode.....	38
Resume from Suspend-to-Disk Mode.....	38
Advanced Power Management.....	39

## Chapter 2: Utilities

Overview .....	41
Power On Self Test (POST) .....	41
POST Messages - Normal operation .....	42
POST Messages - Error Detected .....	43
System Configuration Utility (SCU) .....	44
Invoking the System Configuration Utility .....	44
Working with the Menu Bar of the SCU .....	45
Working with the Pull-Down Menu of the SCU .....	45
Features of the System Configuration Utility .....	46
System Menu .....	46
Devices Menu .....	47
Power Menu .....	49
Exit Menu .....	51
Power On Self Test Definitions .....	52
Debug Codes for PnP BIOS .....	53
Debug Codes for PCI BIOS .....	53
Error Codes Returned by APM Sub-functions .....	54

# Chapter 3: Technical View

Overview .....	55
System Block Diagram .....	56
Chips .....	57
SiS5101 PCI Cache memory Controller .....	58
SiS5102 PCI Local Data Buffer.....	59
SiS5103 System I/O & PMU .....	60
SMC FDC37C669FR I/O FDD Controller with IR.....	62
Omega 82C094 PCMCIA Host Adapter Controller.....	64
ESS ES1788 AudioDrive.....	65
ESS ES690.....	66
ESS ES981 Wavetable Sample Set ROM.....	67
Trident Cyber9385 Flat Panel Controller.....	68
Standard Video Modes .....	69
Extended Video Modes .....	70
Video Mode Cross Reference.....	72
Accessories .....	73
Battery.....	73
Toshiba Ni-MH Rechargeable Battery.....	73
CD-ROM.....	74
TEAC CD-46E-900 .....	74
TEAC CD-36E-900 .....	75
TEAC CD-38E-900 .....	76
3.5" Floppy Disk Drive.....	77
Panasonic JU-226A03F .....	77
TEAC FD-04HF-1300.....	78
LCD Panel.....	79
Sanyo LM-JA53-22NTK 12.1" DSTN.....	79
Samsung LT104S4-151 10.4" TFT.....	80
NEC NL8060AC26-04 10.4" TFT .....	81
Hosiden HLD1201-0151XX 12.1" TFT .....	82
Samsung LT121S1-103 12.1" TFT.....	83
NEC NL8060BC31-01 12.1" TFT .....	84













# Chapter 4: Parts List & Circuit Diagram

Parts List.....	85
Top Case & Assemblies.....	86
Bottom Case & Assemblies .....	88
10.4" Display Panel & Assemblies .....	90
12.1" Display Panel & Assemblies .....	92
CD-ROM.....	94
FDD.....	95
HDD.....	96
Battery Pack.....	97
Circuit Diagrams.....	98

# *Chapter 1: Introduction*

## **Overview**

The Notebook Computer has many advanced features to help you with your computing work. This chapter describes each of the Notebook Computer's hardware features in detail and shows you how to use them. It covers:

-  Specifications.
-  The LED Indicators.
-  Button.
-  System Status LCD Bar.
-  Input/Output.
-  Power.
-  Hardware Configuration.
-  The keyboard.
-  The Storage Disks.
-  The PC Card Slots.
-  The LCD Panel.
-  Power Management.



# Specifications

The state-of-the-art Notebook Computer offers a host of features specially designed to enhance performance and usability:

Architecture	PCI local bus 2.1	
CPU	Intel Pentium	75/90/100/120/133/150/166/200 MHz
BIOS	Plug & Play 1.0a	256KB flash ROM
Second Memory		256KB synchronous cache
DRAM Power Management	Two banks APM 1.1	8MB up to 72MB (8/16/32/40MB)
		Standby mode
		Suspend to memory
		Suspend to disk
Display	LCD panel	TFT/DSTN
	Resolution	800 x 600 (SVGA)
	Video DRAM	2MB
	VPM provider	VPM 1.1
PC Card	ZV-port support	Type IIx3 or
		Type IIx1 + Type IIIx1
Multiple Input/Output	Trackpad	1 (PS/2)
	Serial port	1 (high speed 16C550 compatible)
	Parallel port	1 (EPP/ECP mode support)
	External monitor port	1
	External PS/2 port	1
	RCA jack	1 (NTSC/PAL TV-output)
	Expansion port	1 (168 pin)
	Infrared	1 (IrDA/ASKIR)
	MIDI/Game port	1
Audio System	Compatibility	Sound Blaster Pro
		Microsoft Windows Sound System
		MPU-401
		General MIDI
	Digitized sound	16-bit stereo
	Synthesized music	FM synthesizer
		Wave Table synthesizer (1MB ROM)
	Input/Output	Microphone-in
Line-in		
Headphone		
Built-in speakers	2	
Built-in microphone	1	
Keyboard		Windows 95
Storage	Hard disk	2.5", transfer rate up to PIO Mode 4
	Floppy disk	3.5", 1.44MB high density
	CD-ROM	5.25", IDE
AC/DC Power	AC input	100~240VAC, 47~63Hz, 1.2A
	DC output	20V, 1.5A
	Charger output	12~19V, 1.4A
	Total output	50W
Battery Power	Type	Ni-MH
	Voltage	12V
	Capacity	3000/3500 mAh (10 cells)
Physical	Dimension	302mm (w) x 234mm (d) x 54mm (h)
	Weight	3.4Kg

# LED Indicators

Two LED indicators are integrated to alert you of the system's power status.



Color of Light	Status
Green	System power on (either by AC or by battery)
Red	Battery in charge
Orange	Battery in charge when system power on



Color of Light	Status
Green	Internal battery fully charged
Red	Second battery fully charged
Orange	Both batteries fully charged

## Power Switch Button



This button is used either to turn the system on or to turn it off.

## Microphone



This is a built-in input device for audio system.

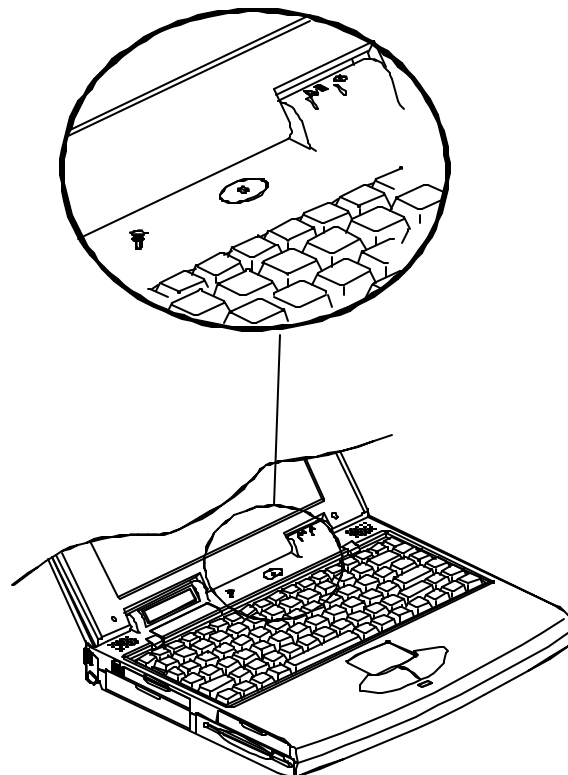

## System Status LCD Bar

The Notebook Computer features a LCD panel bar to display the system's operation status.



### AC Power in Use

The system is using AC power for operation.



### Battery Low (*Flash*)

The battery power is reaching a critically low level.



### CD-ROM in Use

This indicator displays that the CD-ROM drive is being accessed.



### FDD in Use

This indicator displays that the floppy disk drive is being accessed.



### HDD in Use

This indicator displays that the hard disk drive is being accessed.



### Suspend to Memory

This indicator displays that the system has entered the *Suspend to DRAM* Mode.



### Turbo Speed

This indicator displays that the system is running in the maximum speed of the CPU.



### Scroll Lock

This indicator displays that the scroll lock function is activated.



### Caps Lock

This indicator displays that the caps lock function is activated.

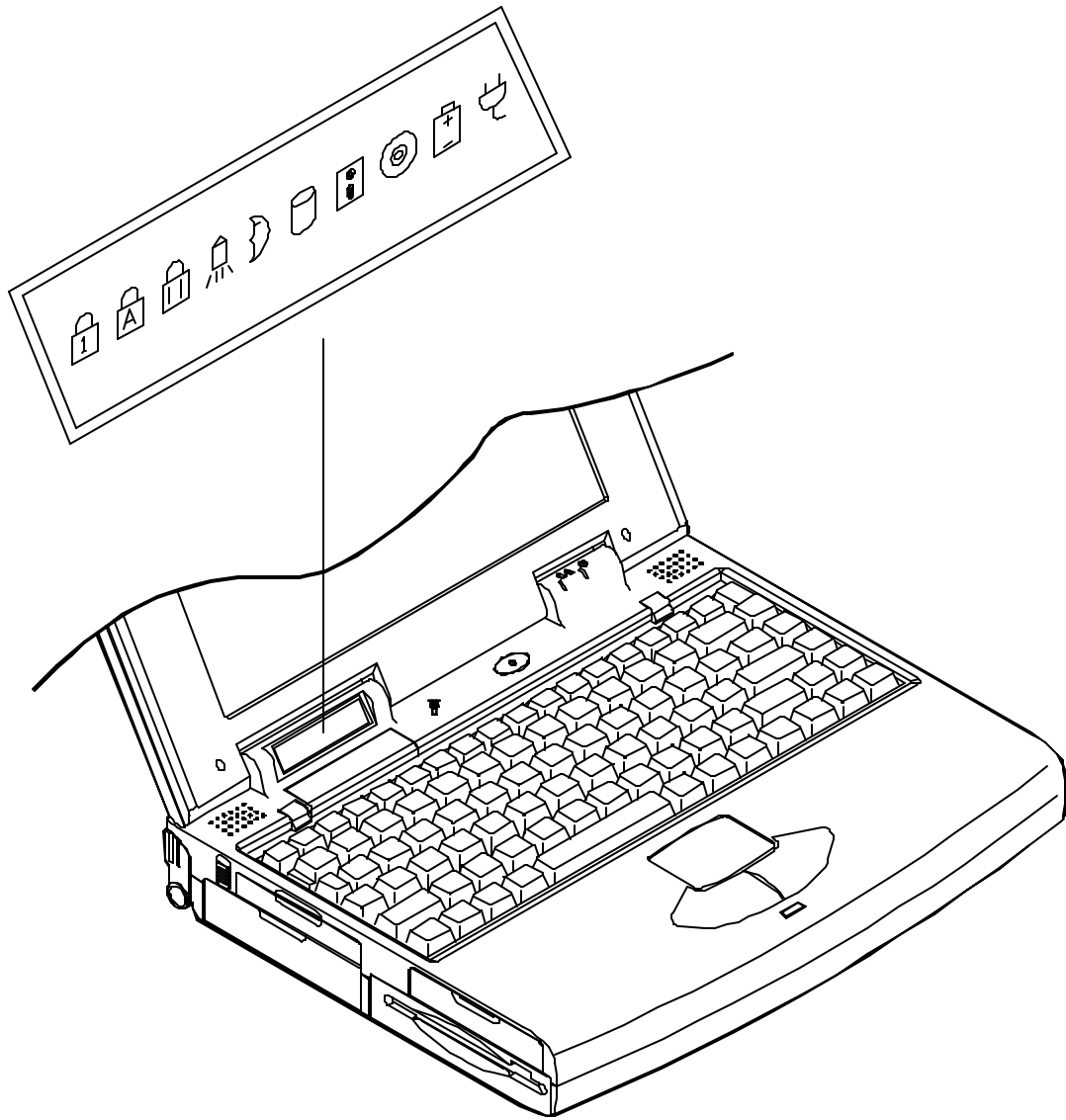

## Top-Front View

Opening the hinged top cover of the system unit will reveal the followings:

### **LCD Panel**

This is the Notebook Computer's flat panel display. It is VGA compatible and driven by a PCI local bus controller for high performance.

### **System Status LCD Bar**

The LCD panel bar will display the system status indicating the respective concerned icons.

### **Dual Stereo Speakers**

These are two built-in output devices on each side for audio system.

### **Trackpad Pointing Device**

The trackpad pointing device features a sensitive glide pad for precise control of the cursor with just a fingertip along with two buttons.

### **Windows 95 Keyboard**

The Windows 95 keyboard gives the user a consistent mechanism for accessing functionality in Windows 95 and in individual applications.

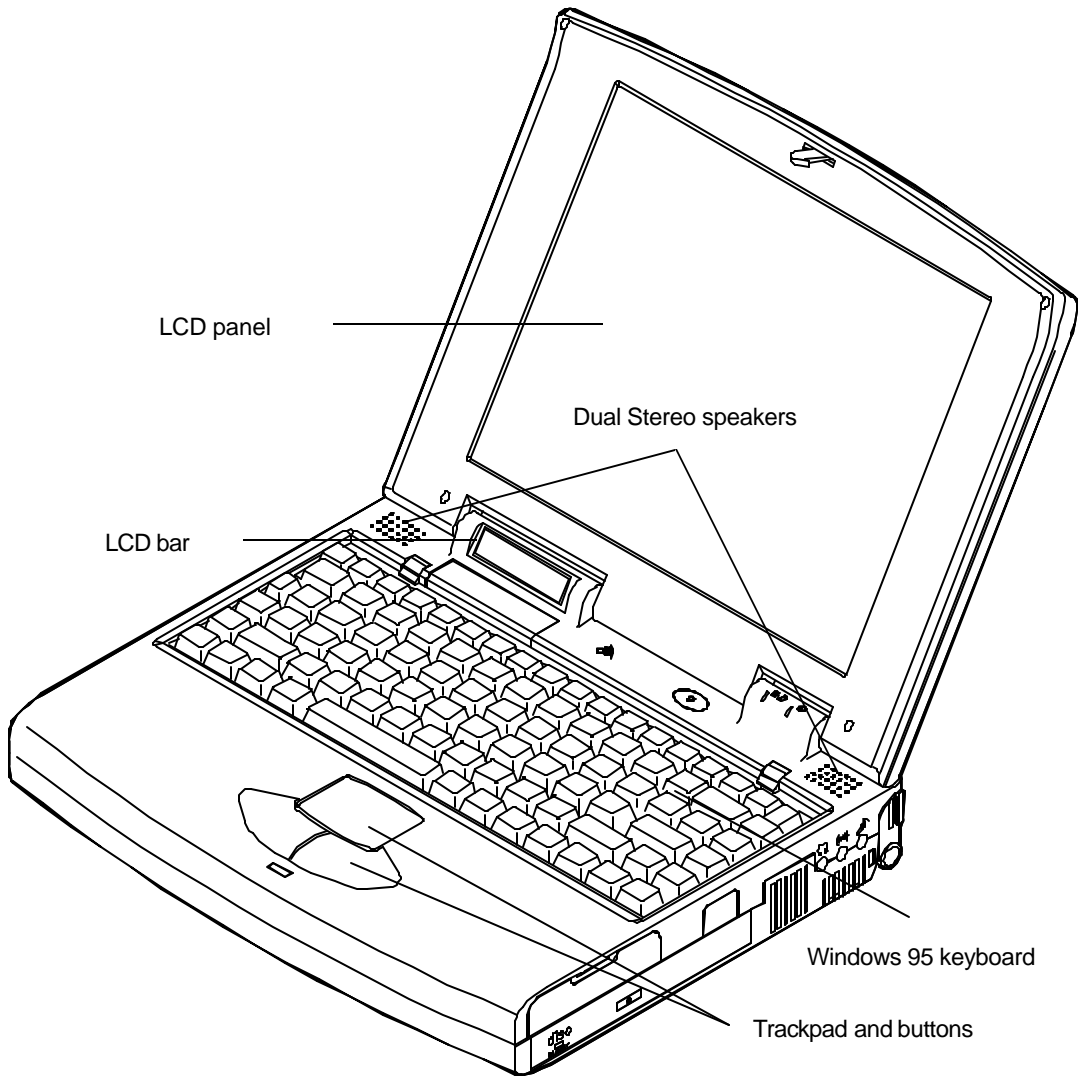

## Right View

On the right side panel, you will find the followings:

### Right-Side Stand

Slide this stand outward (together with the left-side stand) to adjust the viewing angle.



### Microphone-in Jack

This audio port accepts sound source to record or to playback when externally connected microphone is used instead of the built-in one.



### Line-in Jack

This audio port accepts sound source to record or to playback when the sound source comes from other device's audio output than the system's.



### Headphone Jack

This audio port accepts sound source to playback if externally connected headphone is desired instead of the built-in speakers.

### Infrared

The wireless communications capabilities are based on IrDA (Infrared Data Association) standards for cordless connection between the Notebook Computer and an IrDA-compliant device.

### PC Card Type III Expansion Slot

The Type III PC Card slot is located inside a flip-down panel. It allows you to conveniently attach numerous accessories to the Notebook Computer. It is equivalent to two Type II PC Cards slots. The ejection button for the upper slot is located on the left. The ejection button for the lower slot is on the right.

### CD-ROM Drive

The 5.25" IDE CD-ROM drive uses the tray loading mechanism for ease of use. Press the ejection button to load the tray from the drive unit.

### Ventilation

The Notebook features a ventilation to dissipate the system's operating heat. Do not block or obstruct it during operation.

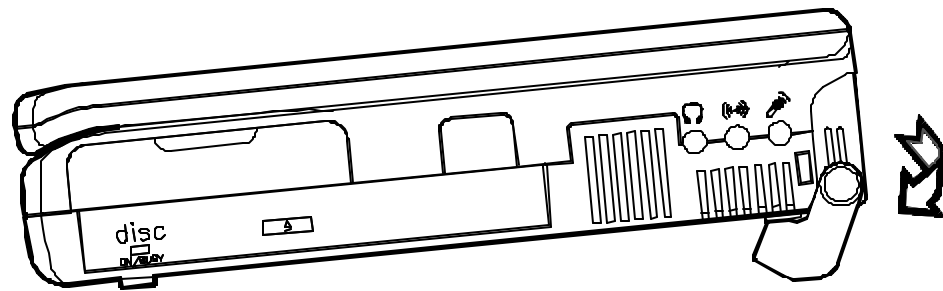
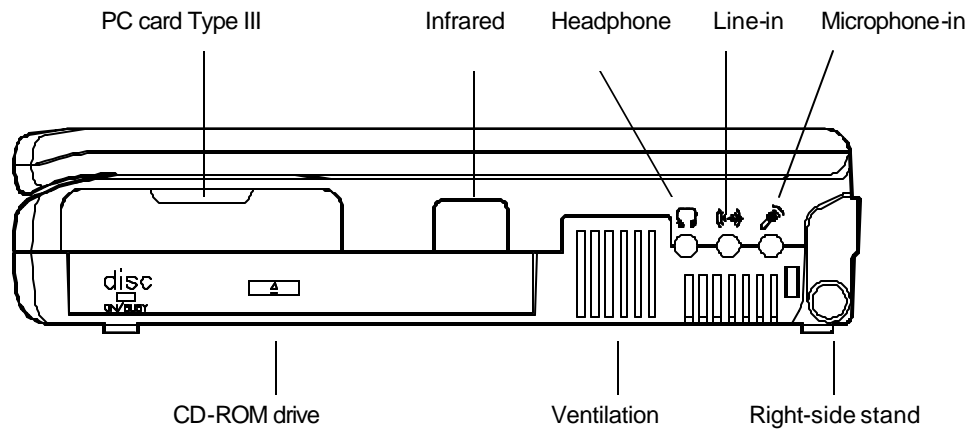



## Rear View

The rear panel of the Notebook Computer offers several ports for the electrical connection to peripheral devices.

### DC-in Socket

This socket is where the Notebook Computer's universal AC/DC power adapter is connected to the system. To disconnect the power adapter, pull the plug (not the cord) directly back.



### Serial Port

This is a high speed NS16C550 compatible port to connect an external mouse for example.



### Expansion Port

This port is used to connect the proprietary Docking Station. All of the features of the Docking Station are available through the plug-in process offering the Notebook Computer access to a desktop system.



### RCA Jack

This is an RCA jack to connect a TV set for example.



### External Monitor (CRT) Port

This port allows the connection of an external monitor to the system. It uses a 15-pin connector and supports super-VGA, and Simultaneous display of LCD and CRT.



### MIDI/Game Port

This port is used to either connect any MIDI device such as a MIDI instrument or keyboard, or connect an external standard joystick.



### Parallel Port

This is a parallel port to connect a printer for example. It supports EPP (Enhanced Parallel Port) and ECP (Extended Capabilities Port) modes, but required as well is the use of the connected parallel device's software driver.



### External Keyboard or PS/2 Mouse Port

An external keyboard is able to be connected to the system via this port. So is an external PS/2 mouse to the system as another pointing device choice.

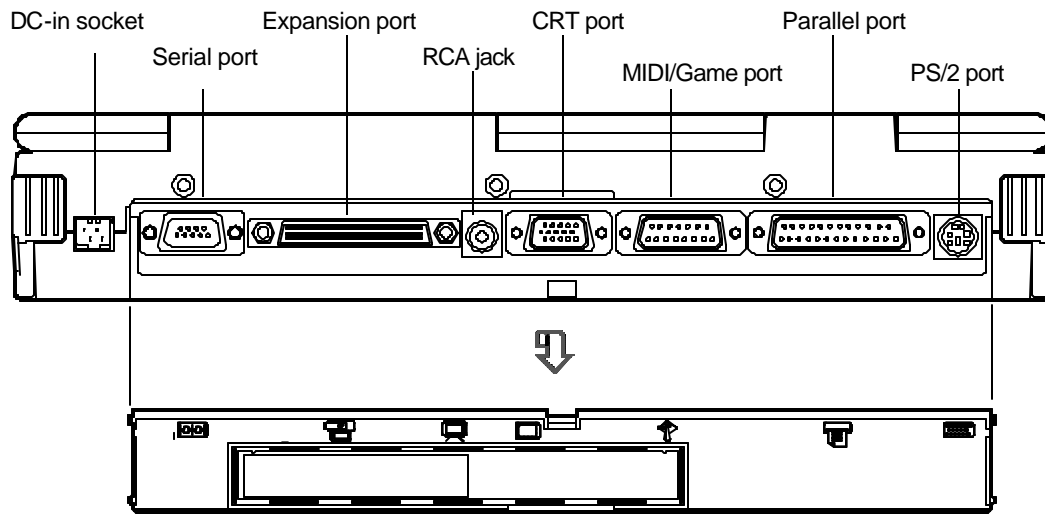

## Left View

The left side of the Notebook Computer features the followings:

### **Left-Side Stand**

Slide this stand outward (together with the right-side stand) to adjust the viewing angle.

### **Battery Latch**

Sliding the battery latch upward will unload the battery pack.

### **PC Card Type II Slot**

The PC Card slot will accommodate a Type II format for system expansion capability.

### **2.5" Hard Disk Drive**

The system's 2.5" hard disk features a high capacity for data storage providing high access time for excellent performance.

### **3.5" Floppy Disk Drive**

This is the location of the Notebook Computer's 3.5" high density 1.44MB floppy diskette drive. You may press the button on its top-right side for diskette ejection.

### **Internal Battery Pack**

The Notebook Computer's internal rechargeable battery pack provides the system with the power for long run time.

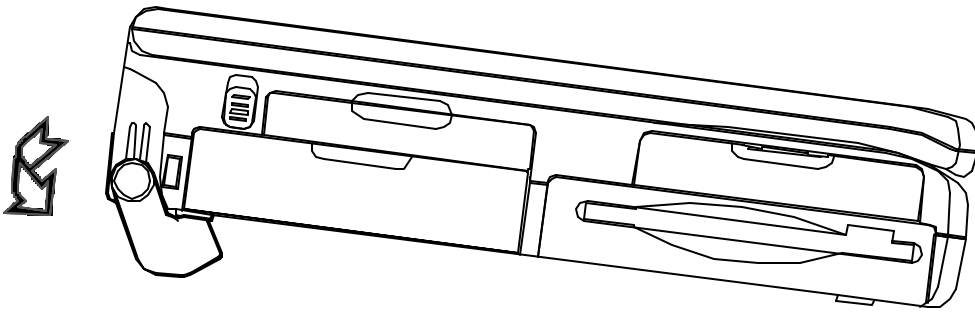
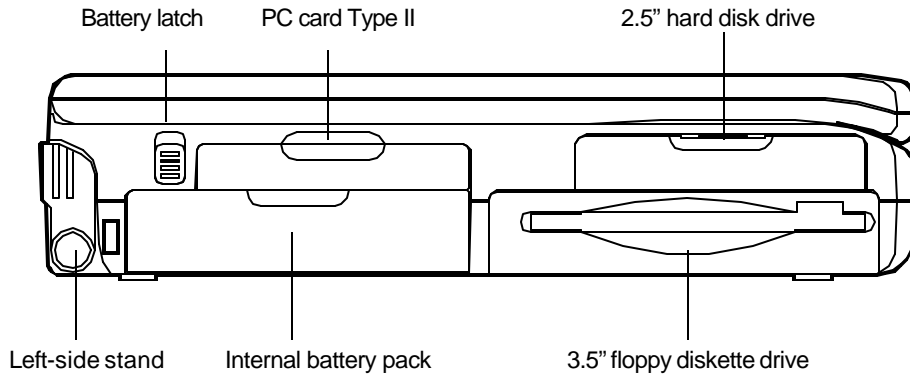

# Power

Before using the Notebook Computer, you must supply it power. If this is the first time the Notebook Computer is operated, you should use the AC power source since the internal battery pack may have self-discharged during shipment.

## AC Power

The Notebook Computer features a universal, auto-switching power adapter. This adapter is suitable for use nearly anywhere.

1. Connect the AC power cord to the power adapter.
2. Plug the power adapter to the DC-in socket on the rear panel of the Notebook Computer.
3. Plug the AC power cord into a properly grounded outlet.

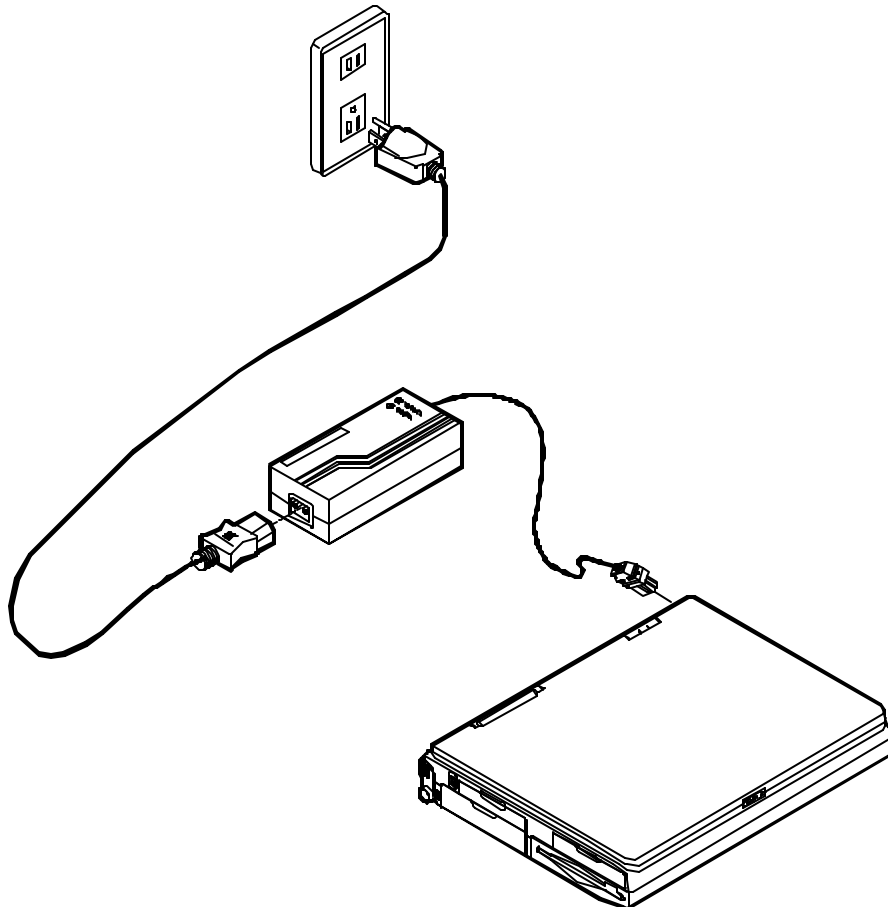

## Internal Battery Power

The Notebook Computer is equipped with an internal, rechargeable battery pack which provides continuous portable operation.

Proper care is required for optimum performance:

- Do not attempt to disassemble the battery under any circumstances.
- The battery may explode if exposed to fire or high temperatures.
- Avoid short circuit the battery by the metal terminals (+, -).

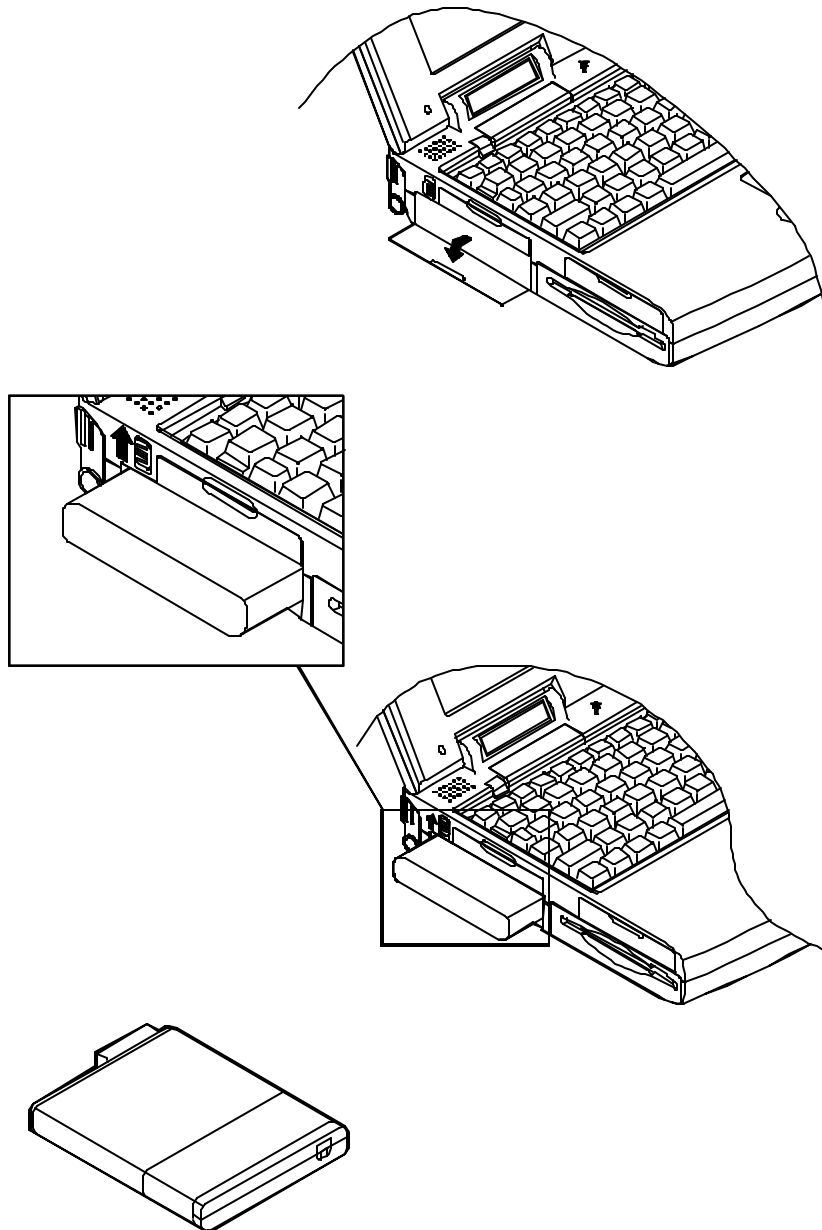

### ***Duracell Smart Battery at Retail***

You may replace with Duracell Smart Battery, available at retail outlets around the world, to accurately indicate a fuel gauge of the predicted available charge for the present state information.

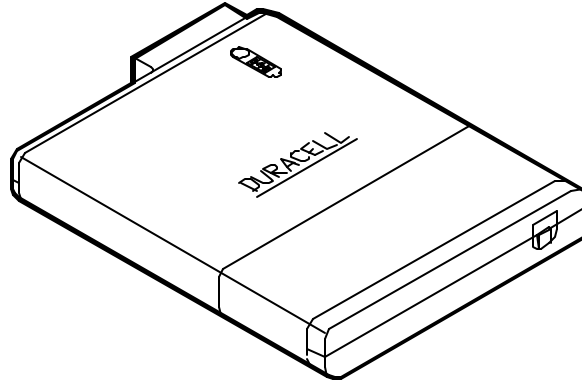

### ***Recharged by AC Power***

The system's battery pack will recharge whenever the system is plugged into the AC power supply, regardless if the system is being operated or not. Hours may be needed to charge the battery pack for long service life.

Some instructions should be carefully concerned before you charge the battery pack:

- Upon the very first use, or after a long period of storage, the system might indicate that charging is complete after just a short time. Simply remove the battery to cool it off and then repeat the charging procedure at least three times.
- It is recommended to fully discharge the battery before charging to keep *memory effect* from capacity loss.

## Second Battery Power (Option)

The Second Battery comes designed, in addition to the system's internal one, to prolong the battery life for the unit's portable use.

You may need to replace the floppy disk out of the 3.5" drive bay with the Second Battery pack for longer power life.

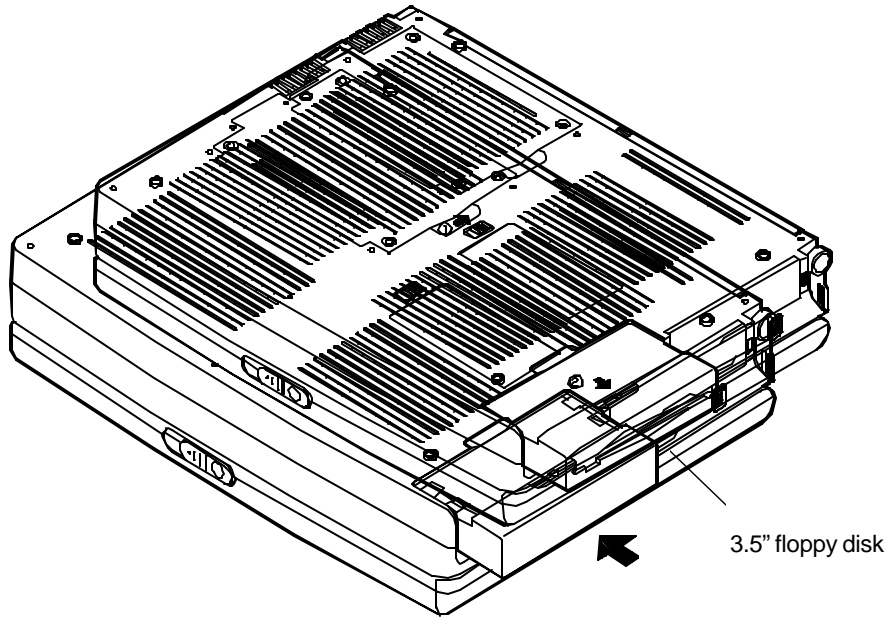

Second battery pack

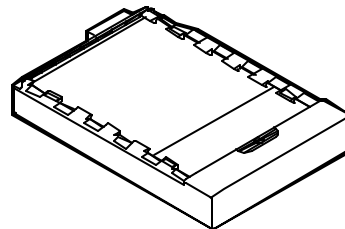



### ***Duracell Smart Battery at Retail***

You may replace with Duracell Smart Battery, available at retail outlets around the world, to accurately indicate a fuel gauge of the predicted available charge for the present state information.

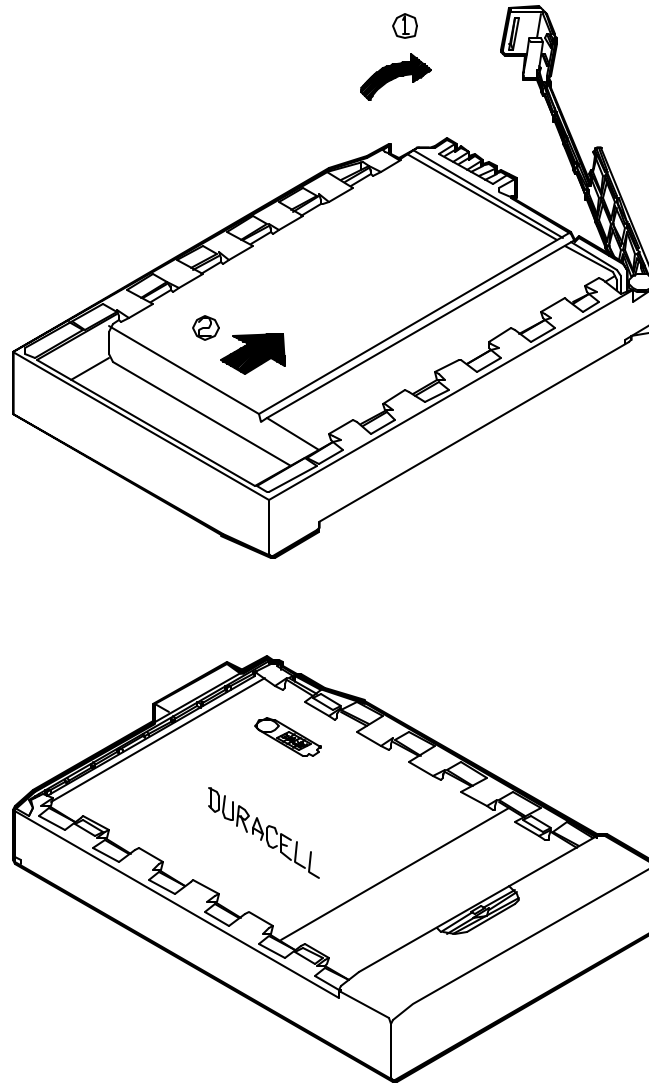

### ***Recharged by AC Power***

The Second battery is charged the same way you do the internal one.

# Operation

## Hardware Configuration

Disconnect all power supply both AC adapter and battery pack before work on any hardware setting.

### CPU

The system is upgradeable with a wide range of speed and voltages of the Intel Pentium processors, providing user with a Zero-Insertion-Force (ZIF) socket to facilitate removal of the Pentium processor and installation of an upgraded one.

#### ZIF Socket

1. Lever along with a slotted screwdriver on the ZIF socket's OPEN position to unlock the CPU.
2. Aligning the CPU's index corner with the socket's to install the CPU into place.
3. Lever along with a slotted screwdriver on the ZIF socket's CLOSE position to lock the CPU.

#### Heat Sink & Fan for CPU

1. Use a sharp-less tool to arrange the cable clockwise along the fan but outside the two screws.
2. Attach to the installed CPU.
3. Connect the properly seated cable to the mainboard for CPU temperature dissipation.
4. Reinstall the four screws surrounding the fan to fasten the heat sink. (Work at each other's opposite angle is recommended for equal attachment.)

#### Speed of CPU

Pentium	75 MHz	90 MHz	100 MHz	120 MHz	133 MHz	150 MHz	166 MHz	200 MHz
S2-1	Off	On	Off	On	Off	On	Off	Off
S2-2	On	Off	Off	Off	Off	Off	Off	Off
S2-3	Off							
S2-4	Off							
S2-5	Off	Off	Off	On	On	On	On	Off
S2-6	Off	Off	Off	Off	Off	On	On	On

#### Power of CPU

The power of CPU varies with the CPU's voltage supply. You may need to attach the proper circuit board of *Power of CPU* responding to the CPU you install.

- 3.3 volts
- 3.1 volts
- 2.9 volts

#### MPEG Accelerator Card (Option)

The *MPEG Accelerator Card* is optional for multimedia use of the system to playback a variety of video formats.

Detailed information is available from the dealer near you upon request.

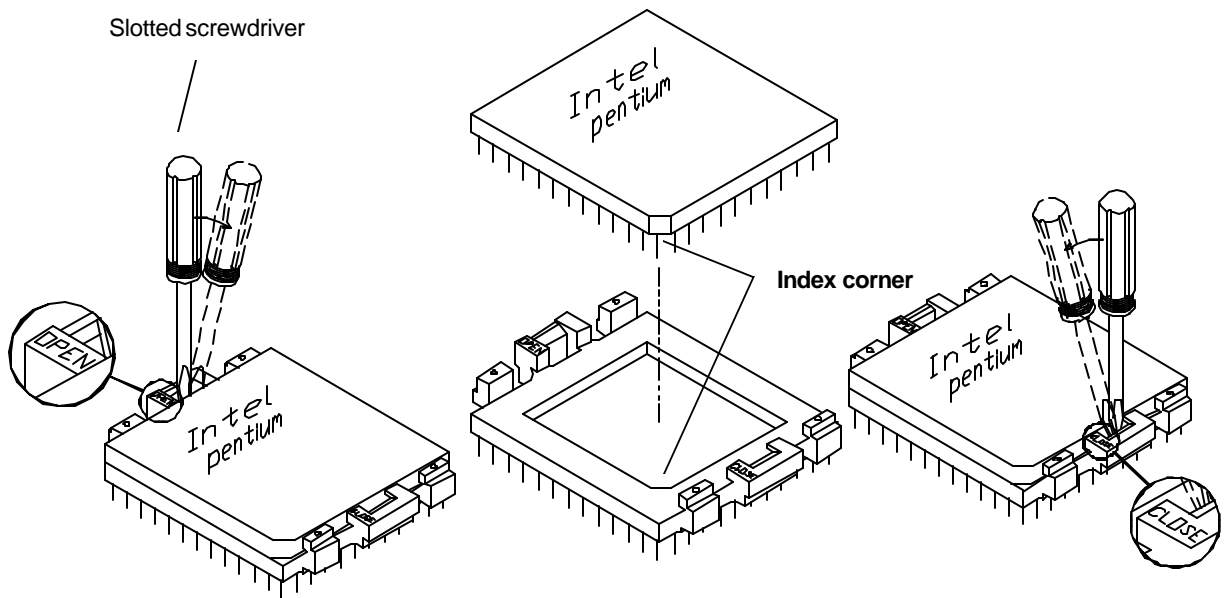
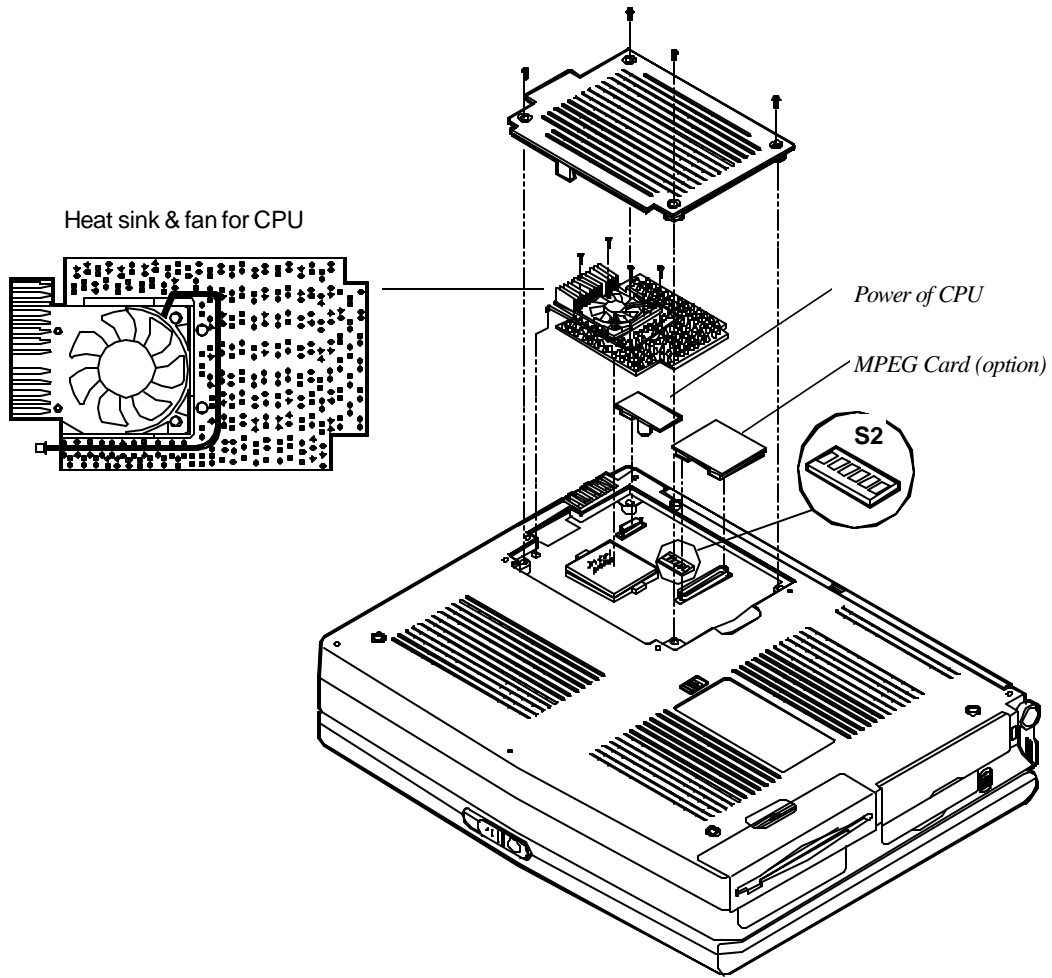

1. Unlock the CPU.

2. Install an upgraded CPU.

3. Lock the CPU.

## RAM Configuration

The system features an expandable Dynamic RAM in small outline 144-pin DIMM (Dual In-line Memory Module) package.

Bank 0 (64 bit)	Bank 1 (64 bit)	Power Voltage	Access Time	RAM Size
(1Mx16)x4	None	5V	70ns	8MB
None	(1Mx16)x4			8MB
(1MX16)X4	(1Mx16)x4			16MB
(1MX16)X8	None			16MB
None	(1MX16)X8			16MB
(2MX8)X8	None			16MB
None	(2MX8)X8			16MB
(1MX16)X8	(1Mx16)x4			24MB
(1MX16)X4	(1MX16)X8			24MB
(1MX16)X8	(1MX16)X8			32MB
(4MX4)X16	None			32MB
None	(4Mx4)x16			32MB
(2MX8)X8	(2MX8)X8			32MB
(2MX8)X8	(1MX16)X8			32MB
(1MX16)X8	(2MX8)X8			32MB
(4Mx4)x16	(1MX16)X4			40MB
(1Mx16)x4	(4Mx4)x16			40MB
(4Mx4)x16 + (1Mx16)x4	None			40MB
(4Mx4)x16 + (1Mx16)x4	(1MX16)X4			48MB
(4Mx4)x16 + (1Mx16)x4	(1MX16)X8			56MB
(4Mx4)x16	(4Mx4)x16	64MB		
(4Mx4)x16 + (1Mx16)x4	(4Mx4)x16	72MB		

## TV-Output

Select the TV standard for video output if a TV set is connected for Games or MPEG playback, for example. The system display will improve video quality for screen flicker caused by an interlaced TV monitor.

	NTSC	PAL
S1-1	On	Off
S1-2	Off	On
S1-3	On	Off
S1-4	Off	On

Provided herein is the international TV system for reference. Any discrepancy should be subject to the local TV standard.

Country	TV System	Country	TV System
Afghanistan	PAL	Liberia	PAL
Algeria	PAL	Madeira	PAL
Argentina	PAL	Malaysia	PAL
Australia	PAL	Malta	PAL
Austria	PAL	Mexico	NTSC
Bahamas	NTSC	Netherlands	PAL
Bahrain	PAL	Neth. Antilles	NTSC
Barbados	NTSC	New Zealand	PAL
Belgium	PAL	Nicaragua	NTSC
Bermuda	NTSC	Nigeria	PAL
Bolivia	NTSC	Norway	PAL
Brazil	PAL	Oman	PAL
Brunei	PAL	Pakistan	PAL
Burma	NTSC	Panama	NTSC
Canada	NTSC	Paraguay	PAL
Canary	PAL	Peru	NTSC
Chile	NTSC	Philippines	NTSC
China	PAL	Portugal	PAL
Colombia	NTSC	Puerto Rico	NTSC
Costa Rica	NTSC	Qatar	PAL
Cuba	NTSC	Sabah/Sarawak	PAL
Cyprus	PAL	St. Kitts	NTSC
Denmark	PAL	Samoa	NTSC
Dominican Republic	NTSC	Sierra Leone	PAL
Ecuador	NTSC	Singapore	PAL
EL Salvador	NTSC	South Africa	PAL
Equatorial Guinea	PAL	Spain	PAL
Finland	PAL	Sri Lanka	PAL
Germany	PAL	Surinam	NTSC
Ghana	PAL	Swaziland	PAL
Gibraltar	PAL	Sweden	PAL
Guatemala	NTSC	Switzerland	PAL
Haiti	NTSC	Taiwan	NTSC
Honduras	NTSC	Tanzania	PAL
Hong Kong	PAL	Thailand	PAL
Iceland	PAL	Uganda	PAL
Indonesia	PAL	United Kingdom	PAL
Ireland	PAL	USA	NTSC
Israel	PAL	Venezuela	NTSC
Italy	PAL	Vietnam	NTSC
Jordan	PAL	Yemen	PAL

Kenya	PAL	Yugoslavia	PAL
Korea South	NTSC	Zambia	PAL
Kuwait	PAL		

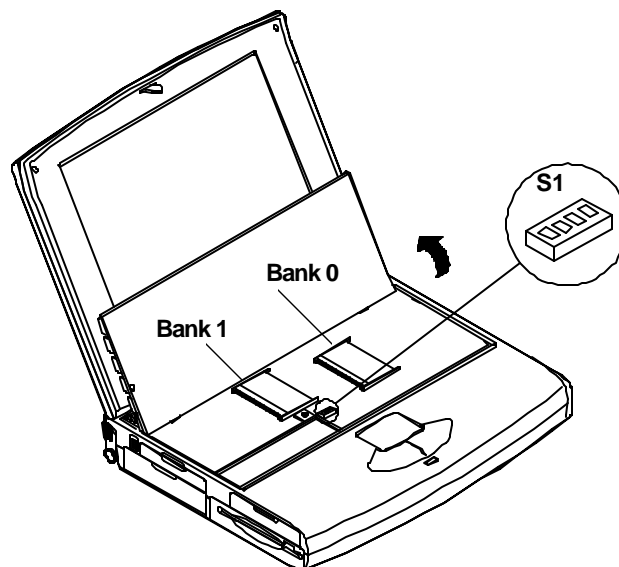
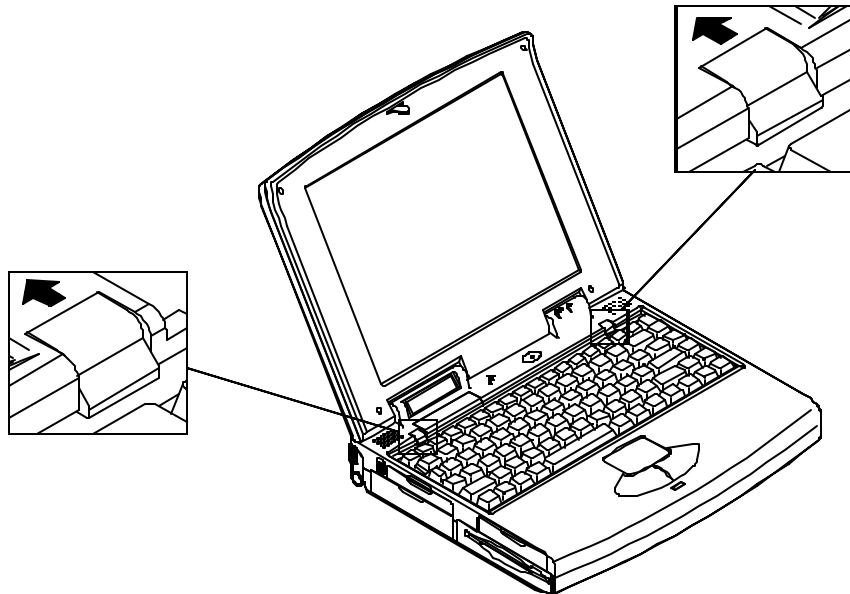

# The Keyboard

The Notebook Computer utilizes an 86 key keyboard detachable for various language versions. It is laid out slightly differently from a standard AT keyboard, but it offers all of the same functions plus some special specific features of the system.

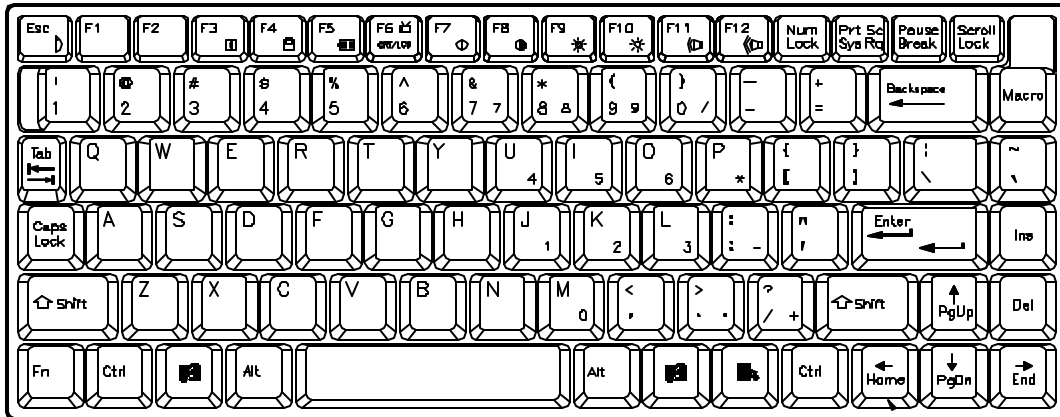

## System Function Key

Located on the bottom-left edge of the Notebook Computer keyboard is an Fn key. It is a special key only found on the Notebook Computer and it is used for operation of:

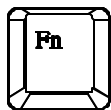

- The PgUp, PgDn, Home, End keys.
- The embedded numeric keypad.
- The hot key.

## Cursor Control Keys

Four cursor control keys, also called Arrow or Direction keys, are located below the Enter key. The colored function will need to be used with the system function key.

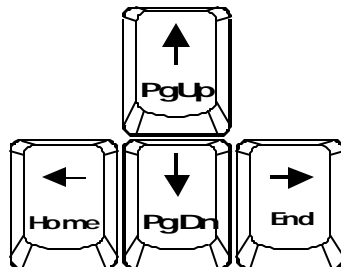

- ☞ PgUp
- ☞ PgDn
- ☞ Home
- ☞ End



## Embedded Numeric Keypad

The colored keys in the middle of the keyboard are capable of providing numeric keypad functions.

Press the NumLock key to lock the numeric keypad. The NumLock indicator will be displayed on the system status LCD bar.

Press the Fn key with the keys of the embedded numeric keypad to operate with the colored number and symbol keys.

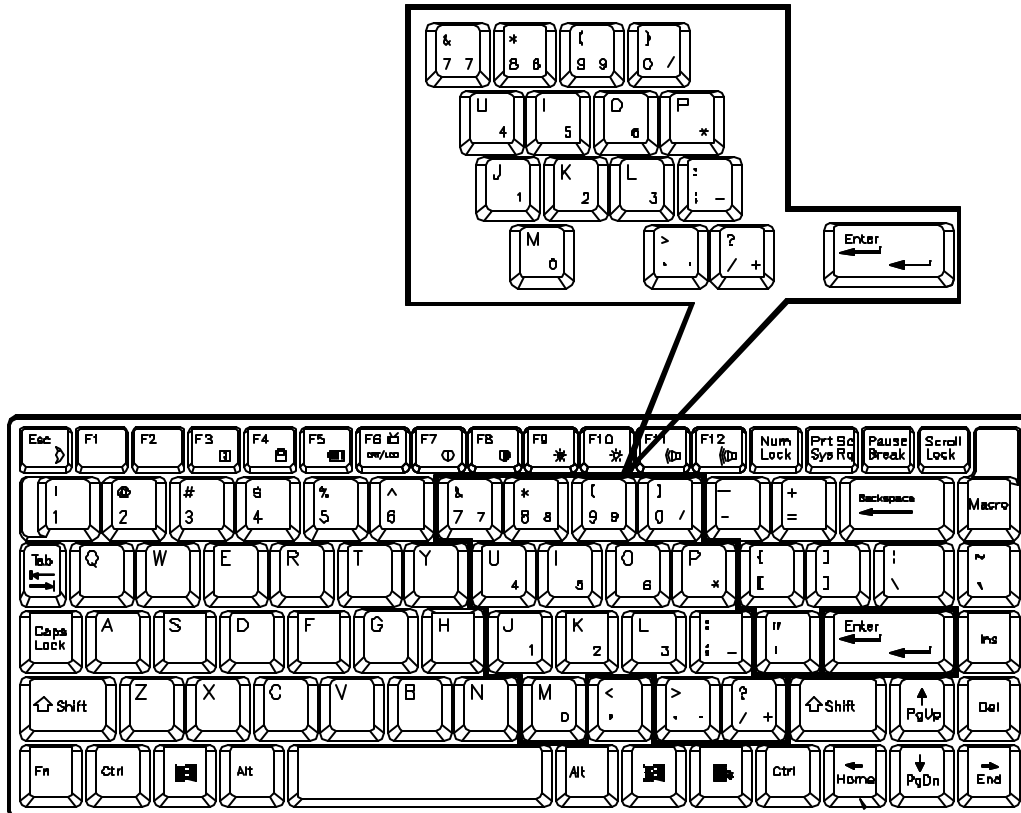

## Hot Keys

Located along the top of the keyboard are 12 numbered “F” keys. The functions of these “F” keys are defined as the followings:

### Expanded Display Mode

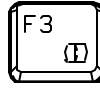
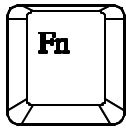

The aspect ratio of display panels is not the same as CRT monitors. Therefore, the display may not completely fill the entire display panel. Expanded mode will stretch the display to fill the entire viewing area of the display panel.

### Display Type

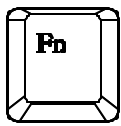

Display type mode allows you to switch display among LCD only, CRT only, TV only, both LCD and CRT.

### Contrast Control

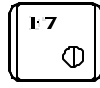
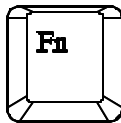

Contrast control allows you to adjust the contrast of the display panel. *This feature is available for DSTN panel only.*

### Brightness Control

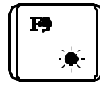
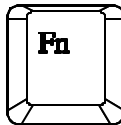

Brightness control allows you to adjust the brightness of the display panel.

### Volume Control

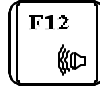
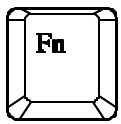

Volume control allows you to adjust the volume of the audio system.

### Contrast/Brightness Saved

You may save the display contrast and brightness for the LCD panel.

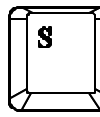
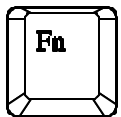

### Suspend Mode

Put the system in a suspend state for power management. The system can be resumed from exactly where it was left off.

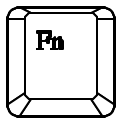

## New Keys for Windows 95

### Application Key

When the user presses the unmodified Application key, the application brings up the Context menu (a pop-up menu) at the current selection, much as pressing the right mouse button does in some applications today. Pressing the Application key does not disturb the current cursor position.

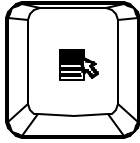

### Windows Keys

When the user presses either Windows key - Left or Right - the Start menu appears. Both keys can be used to modify other keys.

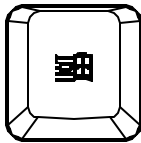

The operating system controls the functionality of the Windows keys. Only shell applications should implement these keys, and then only in such a way as to preserve and extend the keys' functionality in the Windows 95 shell.

## Storage Disks

The Notebook Computer comes equipped with several data storage drives:

- 3.5" Floppy Drive .
- 2.5" Hard Drive.
- 5.25" CD-ROM Drive.

## 3.5" Floppy Drive and Diskettes

The Notebook Computer's floppy diskette drive is labeled drive A: It is capable of starting the system when a bootable diskette is placed in it.

The floppy diskette drive comes designed to be removable for the desired replacement in the 3.5" bay with the *Second Battery pack* for longer system use time.

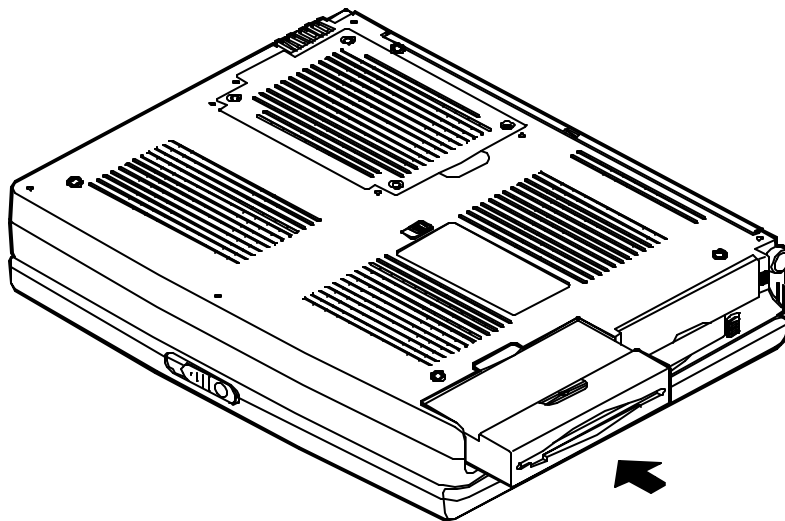
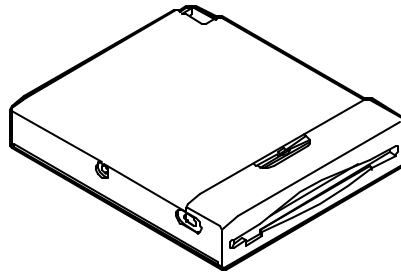
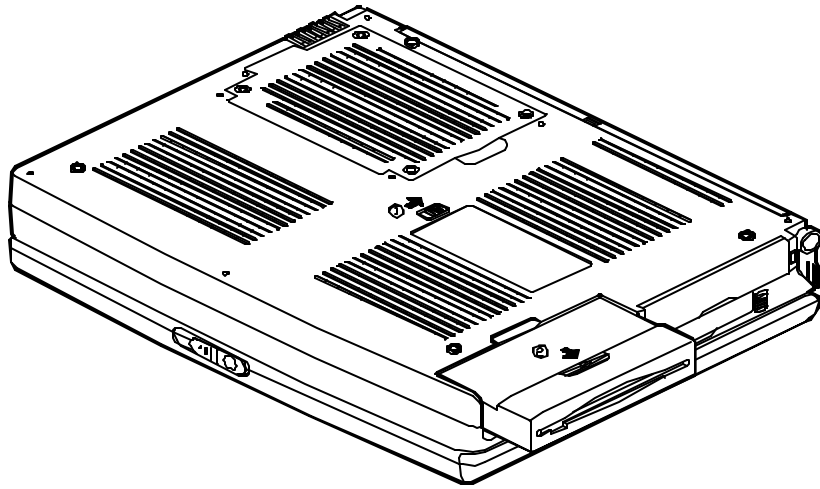

## Inserting/Removing Diskettes

- With the label side up, and the metal shutter toward the disk drive, gently insert the diskette into the drive until the diskette is properly seated.
- To remove the diskette from the drive, press the ejection button on the top-right side of the drive and remove the diskette.

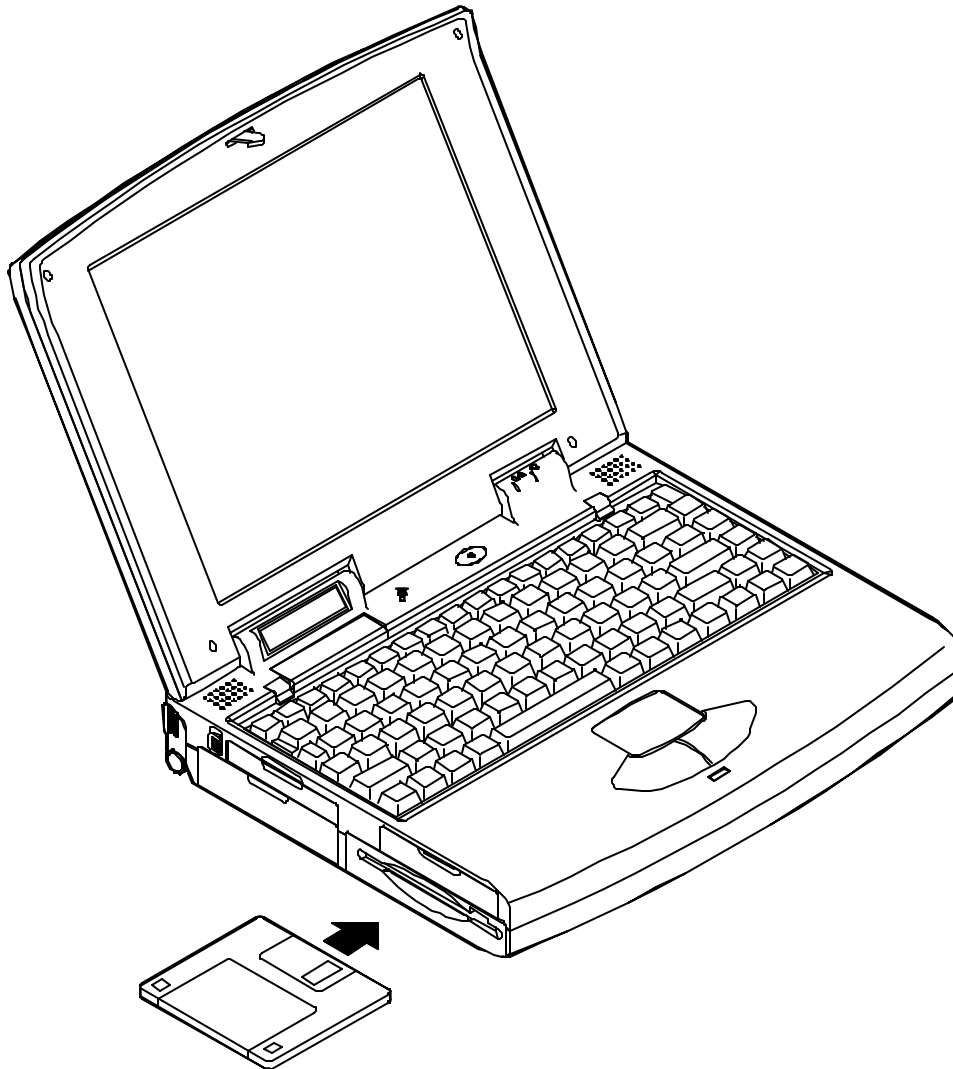

## **2.5" Hard Diskette Drive**

The 2.5" hard diskette drive supports the LBA mode which overcomes the capacity of 528MB constraint as well as high performance data transfer rate at speed up to 16.6 MB/second.

The system will automatically configure the hard disk parameters for any supported IDE drive.

If the hard disk drive is not bootable, you must start the system with a bootable diskette in floppy diskette drive A.

Refer to your DOS manual for more details about hard disk drives, DOS files, starting your system and formatting disks.

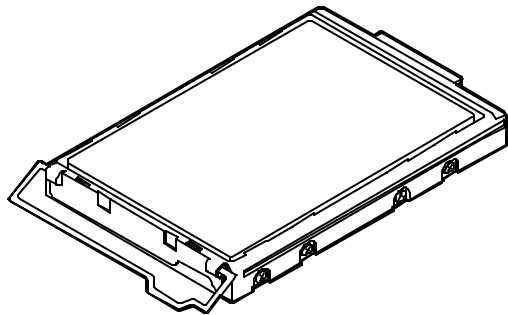
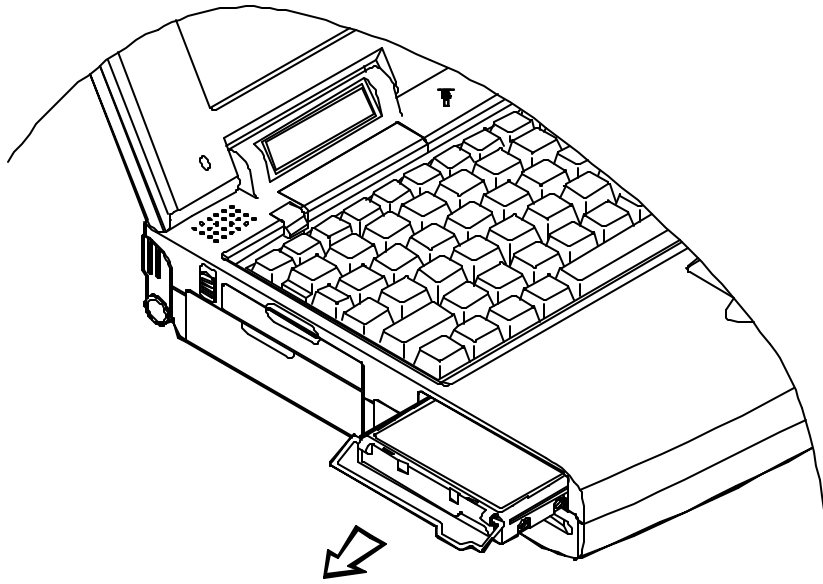
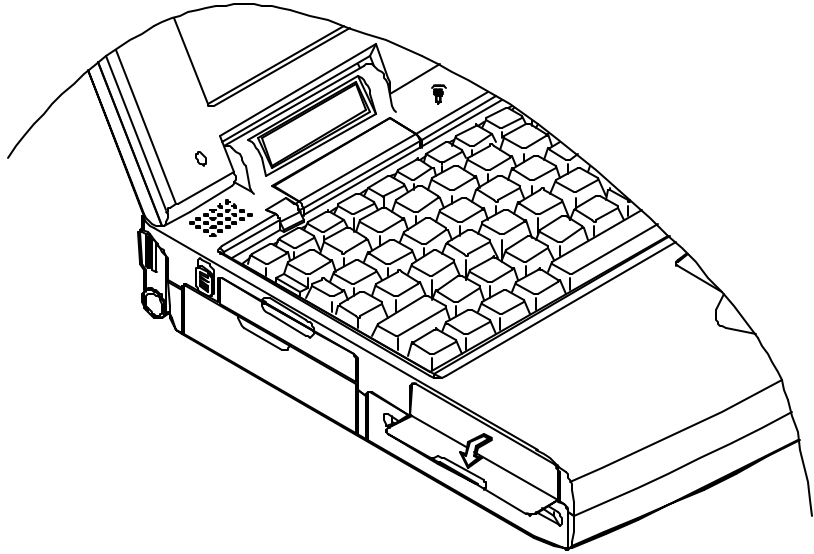



## 5.25" CD-ROM Drive

An IDE 5.25" CD-ROM drive is internally mounted in the system, using the tray loading mechanism for ease of use.

The CD-ROM drive provides the performance required for the multimedia applications in a variety of disc types, such as CD-DA, CD-ROM (Mode-1, Mode-2), CD-ROM XA Mode-2 (Form-1, Form-2), Multi-session Photo CD, and CD-I, Video CD compatible.

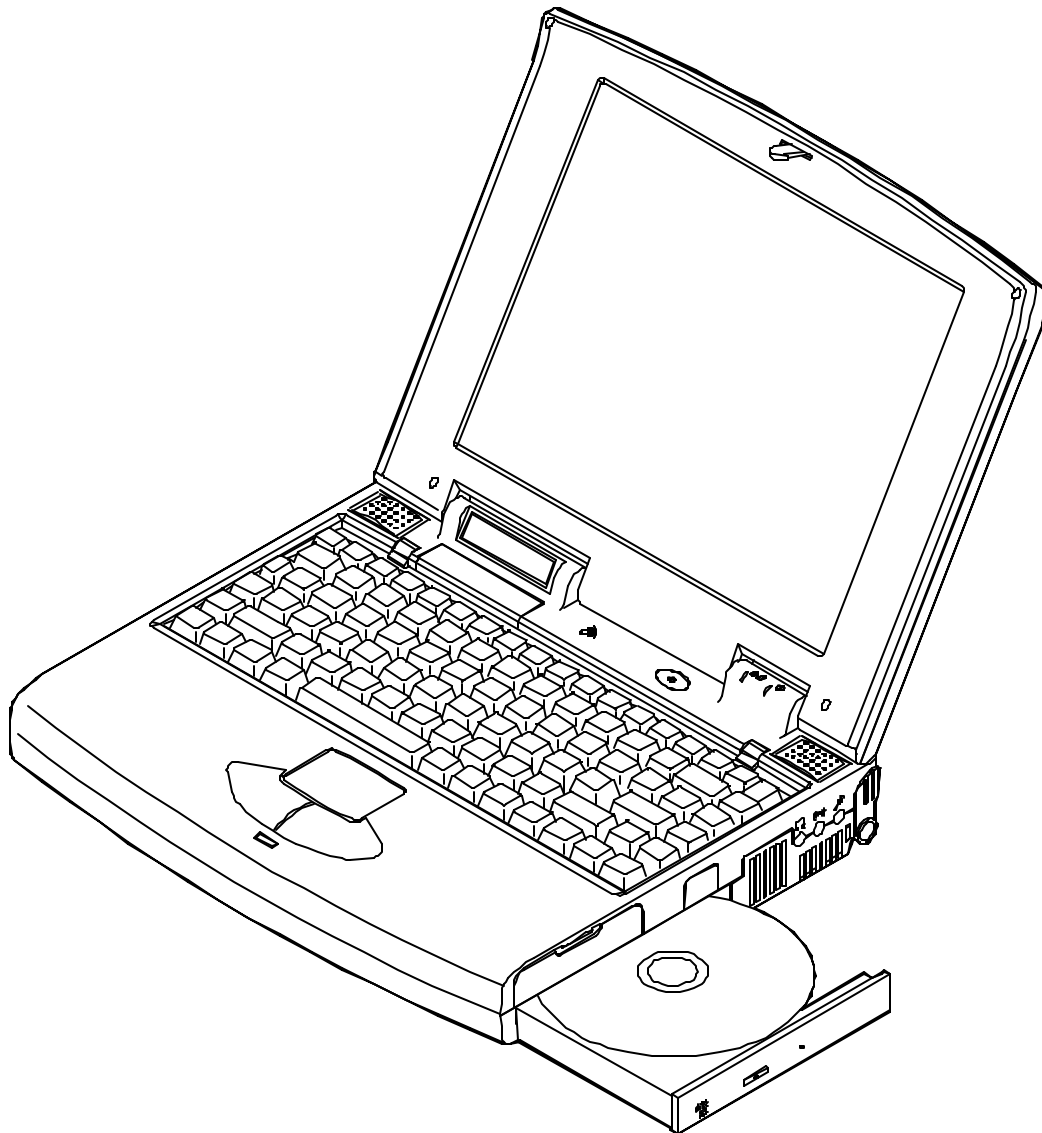

# PC Card Slots

The Notebook Computer includes the expansion slots for a variety of PC Cards.

- Type III x 1 (equivalent to Type II x 2) on the right panel.

☞ Slot 0 located on the lower socket.

Slot 0 supports the **Zoomed Video (ZV) port**, a direct connection between a PC card and a VGA controller. It allows the PC card to write video data directly to an input port of the system's VGA controller, for live video capture and playback for example.

☞ Slot 1 located on the upper socket.

- Type II x 1 on the left panel.

## Inserting and Removing PC Cards

PC cards are inserted and removed in much the same way as floppy disks. Although PC cards are electronic devices, you do not need to turn off the system power to change them. Exit any applications you are using and return to the DOS prompt before inserting or removing a PC card.

- To insert a card into the slot, align the card with the slot and push it in firmly until it locks into place.
- To remove a card from the upper slot, press the eject button on the left side.
- To remove a card from the lower slot, press the eject button on the right side.

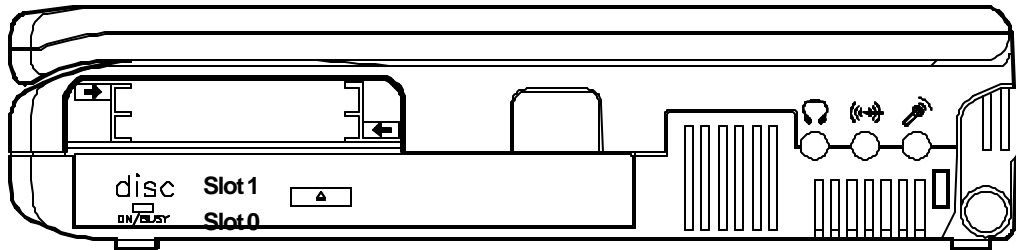

## Configuring and Operating PC Cards

The Notebook Computer's PC Card socket requires the use of software drivers, and the device specific drivers, to control the operation of the socket and any PC Cards inserted into it.

All slots may be used to install:

- ☞ LAN.
- ☞ FAX/modem devices.
- ☞ Memory devices.
- ☞ PCMCIA compatible hard disk drives.
- ☞ Communication devices.

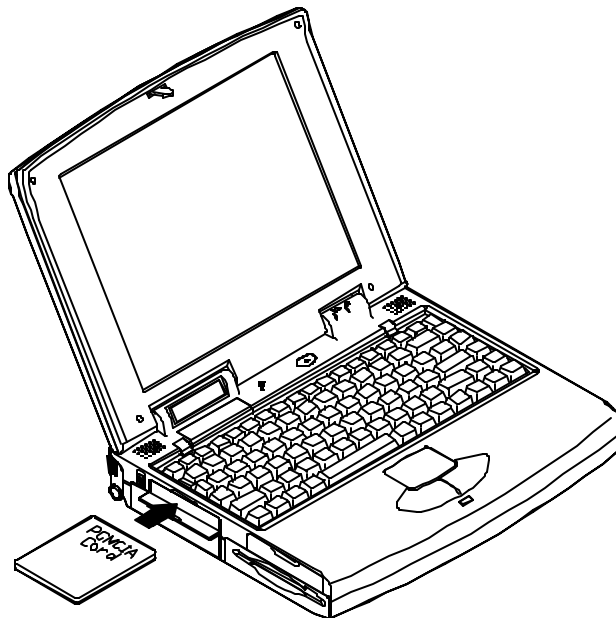
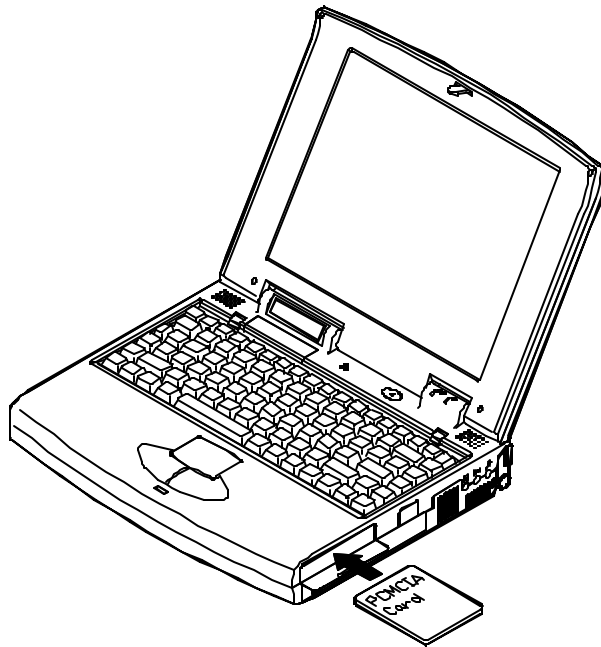

# LCD Panel

The Notebook Computer's features the LCD panel display with the followings:

- PCI local bus controller.
- 2MB video DRAM.
- Capability to support 800x600 (SVGA) resolution DSTN/TFT display.
- Super-VGA resolution output to an external monitor.
- Ability to output the video to other video display device:
  - ☞ VGA monitor (CRT) or RGB projector.
  - ☞ TV set.
- Ability to drive both displays of LCD and other video device simultaneously:
  - ☞ VGA monitor (CRT) or RGB projector.
- VPM (Video Port Manager) provider, the driver-level software, to gain direct control of the display hardware for video input from:
  - ☞ ZV-capable PC Card.

# Power Management

The Notebook Computer provides users with power management to manage power consumption while maintain optimal system performance.

## Standby Mode

Standby Mode is the device level power management. Most controllable peripheral devices, such as hard disk and LCD display, will be powered off. If the STANDBY timer expires before any system activity is detected, the system will change from Standby Mode to Suspend Mode.

## Suspend Mode

Suspend Mode is the system level power management. The CPU and DMA clocks will be halted and all controllable peripheral devices will be turned off.

The system may be suspended by:

- Suspend hot key
- Suspend timeout
- Battery weak

*Be sure not to initialize the Suspend Mode when any of the disk drives is accessed such as HDD, FDD and CD-ROM drive.*

### *Suspend to Memory*

Suspend-to-Memory is a 5-volt suspend mode for system power management.

### *Suspend to Disk*

Suspend-to-Disk is a 0-volt suspend mode for system power management.

1. Use your operating system's FDISK program to delete all partitions of the hard disk if any already exists on the target drive.
2. Boot the system from the A: drive and run the 0VMAKFILEXEXE Utility to create the Suspend to Disk partition on the hard disk whose size will accommodate **the installed DRAM (n) plus 2MB integrated video RAM.**

**A:\>0VMAKFIL /Pn**

For example, if the system DRAM is 72MB, 0VMAKFIL will create a partition of size about 75MB.

**A:\>0VMAKFIL /P72**

*Note: Rewrite the sector signatures if you partition again the very hard disk.*

**C:\>0VMAKFIL /PW**

3. Re-partition the hard disk using your operating system's FDISK program.

## **System Resume**

The system operation can be returned from exactly where it was suspended when a resume event occurs. However, the system may not resume successfully from the Suspend Mode when connected to some external devices, such as PC Card.

### ***Resume from Suspend-to-Memory Mode***

The system may be resumed from Suspend-to-Memory mode by:

- Resume alarm time (hour/minute)
- Modem ring
- Any keyboard key pressed

### ***Resume from Suspend-to-Disk Mode***

The system may be resumed from Suspend-to-Disk mode by:

- Power back on

# Advanced Power Management

The system provides the Advanced Power Management (APM) support to further reduce power consumption especially for battery operation.

The installation of Advanced Power Management (APM) varies depending on the Operating System (OS) and the software application you are using. Refer to their respective manuals for detailed information.

**This page is intentionally left blank.**



# *Chapter 2: Utilities*

## **Overview**

The Notebook Computer has several built-in software utilities to help you get the most from the system hardware. This chapter discusses:

- 📖 Power-On-SelfTest (POST).
- 📖 The System Configuration Utility (SCU).

### **Power On Self Test (POST)**

The BIOS performs a series of power-on-self-test (POST) to diagnose hardware errors when the system first starts up. During the POST procedure, the POST verifies that the hardware is installed and operational. If a hardware problem exists, the POST routine may halt execution (depending upon the severity of the problem).

## POST Messages - Normal Operation

If no configuration errors are detected, the system will be operated after the POST process is completed.

You may press the *Spacebar* key to skip the memory test.

### **System PCI BIOS for SiS-510X Version 1.01.26 Copyright 1983 - 1996 SystemSoft Corp. All Right Reserved.**

System Processor: 200 MHz Intel Pentium CPU  
System External Cache: 256 KB Enabled  
Video Chip: Trident Cyber 9385 with 2 MB Video RAM  
SystemSoft Plug-n-Play BIOS Ver 1.0a

Base Memory	640 Kb
Extended Memory	39936 Kb
Shadow Memory	256 Kb
Reserved Memory	128 Kb
Total Memory	40960 Kb

<CTRL-ALT-S> to enter System Configuration Utility

## POST Messages - Error Detected

If a configuration is detected as a non-fatal error, a WARNING message will be displayed. You should either press F1 key to continue, or press Ctrl-Alt-S key combination to enter the System Configuration Utility.

### **System PCI BIOS for SiS-510X Version 1.01.26 Copyright 1983 - 1996 SystemSoft Corp. All Right Reserved.**

System Processor: 200 MHz Intel Pentium CPU  
System External Cache: 256 KB Enabled  
Video Chip: Trident Cyber 9385 with 2 MB Video RAM  
SystemSoft Plug-n-Play BIOS Ver 1.0a

Base Memory	640 Kb
Extended Memory	39936 Kb
Shadow Memory	256 Kb
Reserved Memory	128 Kb
Total Memory	40960 Kb

WARNING - NO BOOTABLE FLOPPY DRIVE 0 INSTALLED  
WARNING - FLOPPY INFORMATION INVALID - RUN SCU

<CTRL-ALT-S> to enter System Configuration Utility or Press F1 to Continue

# System Configuration Utility (SCU)

The System Configuration Utility (SCU) is a ROM-based configuration utility that displays the system's configuration status and provides users with a tool to set their system parameters. The settings are stored in non-volatile battery-backed CMOS RAM which saves the information even when the power is turned off, and retains that when the system is turned back on.

## Invoking the System Configuration Utility

The System Configuration Utility (SCU) will be accessed when simultaneously press the Ctrl, Alt, and S keys.

**< CTRL-ALT-S > to enter System Configuration Utility**

The above message only lasts seconds. If you miss it, the computer will access its boot process. You must reboot the system and try again within the time limit if you like to enter the System Configuration Utility.

```
SystemSoft Setup Configuration Utility (SCU)      Oct 28, 1996   4:50:05 pm
System  Devices  Power  Exit

----- System -----
CPU Type      = PENTIUM
CPU Clock     = 200 MHz
System DRAM   = 40960 KB
Cache (Ext)   = 256 KB

Point Device  = Enabled

Boot From     = Diskette A

Video Display = LCD and CRT

Boot Password = Disabled

SCU Password  = Disabled

----- Devices -----
Floppy Drive  = 1.44 MB
Hard Drive C  = 775 MB
Serial Port 1 = 3F8H, IRQ 4
Serial Port 2 = 2F8H, IRQ 3
Parallel Port = 378H, IRQ 7
Audio Port    = 220H, IRQ 5, DMA 1
MIDI Port     = 300H
WAVE Table    = Disabled

----- Power Management -----
Saving Mode   = Always On
Saving Level  = Medium
Video Monitoring = Enabled
Battery Weak  = Flash Beeping
Suspend To   = Memory

Press <Alt> key to activate menus, and cursor keys to navigate. Mouse left
button, and <Enter> keys accept menu item. Mouse right button and <Esc> key
cancel current action.
```

## Working with the Menu Bar of System Configuration Utility

Press simultaneously the Ctrl-Alt-S key combination to enter the menu bar of the System Configuration Utility.

Action	Keys Used	Description
Activate menus	Alt	Activate the System Configuration Utility.
Select menu bar item	Left arrow (←) Right arrow (→)	Move to a menu bar item on the left. Move to a menu bar item on the right.
	The highlighted letter key	Move to the correspondent menu bar item.
Accept menu bar item	Mouse left button Spacebar Enter	Enter the selected menu bar item to configure settings.
Cancel current action	Mouse right button Esc	Undo the current command.

## Working with the Pull-Down Menu of System Configuration Utility

When the desired menu bar item is highlighted, press the Enter key to enter the pull-down menu for values setting.

Action	Keys Used	Description
Select pull-down menu item	Down arrow (↓)	Move to the next pull-down menu item.
	Down arrow (↑)	Move to the previous pull-down menu item.
	The highlighted letter key	Move to the correspondent pull-down menu item.
Select a control Change values	Tab Down/Up arrows (↓)(↑)	Move between the options. Modify the settings.
Accept entries	Spacebar	Enable/disable the specified function. When a check mark appears, the function is on.
	Enter	Choose <OK> from a list of options.
Reject entries	Esc	Undo the current setting.
	Enter	Choose <Cancel> from a list of options.
Activate accelerators	Alt	Invoke all the highlighted letters corresponding to their respective options.
Quit	Esc	Press the Esc key to close the pull-down menu.

# Features of the System Configuration Utility

## System Menu

Clicking an option will **enable** the specific capability.

Item	Setting	Function
Date and Time	Day/month/year Hour/minute/second	Sets the current date and time.
Fast Boot		Initializes and quickly boot the system in a few seconds by passing certain diagnostic tests.
Enable Pointing Device		Enables the internal trackpad.
Boot Device	Diskette A	Specifies where the system boots from.
	Hard disk C PCMCIA card	
Video Display	LCD and CRT	Enables both LCD and CRT simultaneously.
	Auto sense	The display auto-switches to CRT if one is sensed.
Video Expansion Enabled		Enables the LCD expanded mode.
System Security	Enter old password	You may enter a password up to 10 printable alphanumeric characters.
	Enter new password	
	Verify new password	
	Enable Booting password	Verifies password every time the system is booted.
	Enable Setup password	Verifies the password every time you try to enter SCU.



## Devices Menu

Clicking an option will **enable** the specific capability.

Item	Setting		Function
Diskette Drive	None		Specifies a drive type for diskette drive A.
	1.44MB		
Hard Disk	Disk Type	None	No hard disk is installed in the system. Modifies the values for cylinders, heads, sectors per track, landing zone, write precomposition and size (MB).
		Custom	
		Auto-ID	
	Enhanced Options	LBA mode	Enables Logical Block Address (LBA) mode to overcome 528MB barrier.
		Multiple sector mode	Enables multiple sector mode to increase sequential data transfers.
		Fast PIO mode	Enables Fast Programmed Input/output (PIO) mode for high data transfer rate.
COM Ports	COM A settings	None	Specifies the COM A configuration.
		3F8H, IRQ4	
		2F8H, IRQ3	
		3E8H, IRQ4	
		2E8H, IRQ3	
	COM B settings	None	Specifies the COM B configuration.
		3F8H, IRQ4	
		2F8H, IRQ3	
		3E8H, IRQ4	
		2E8H, IRQ3	
COM B definition	Serial port 2	Defines COM B hardware.	
	IrDA (HPSIR) IR (ASKIR)		
LPT Port	Port setting	None	Specifies the LPT port configuration.
		378H	
		278H	
		3BCH	
	Port definition	SPP mode	Standard Parallel Port.
		EPP mode	Enhanced Parallel Port.
		ECP mode	Extended Capabilities Port.
	IRQ setting	IRQ5	Specifies IRQ configuration.
		IRQ7	
	ECP DMA setting	DMA1	Specifies ECP DMA configuration.
DMA3			

Item	Setting		Function
Audio Port	Port setting	220H	Specifies the system's audio I/O port address.
		230H	
		240H	
		250H	
	IRQ setting	IRQ9	Specifies the system's audio IRQ configuration.
		IRQ5	
		IRQ7	
		IRQ10	
	DMA setting	DMA0	Specifies the system's audio DMA channel configuration.
DMA1			
DMA3			
MIDI Port	MIDI port	300H	Specifies the system's General MIDI I/O port address.
		310H	
		320H	
		330H	
Wave Table Enabled			Enables Wave Table music synthesizer.
Keyboard Numlock			Specifies NumLock is on at system boot time.
Keyboard Repeat	Key repeat rate	2 cps	Defines the rate (character per second) at which the keyboard repeats while a key is depressed.
		6 cps	
		10 cps	
		15 cps	
		20 cps	
		30 cps	
	Key delay	¼ sec	Specifies the time (second) that will pass after a key is depressed before starts to repeat.
		½ sec	
		¾ sec	
		1 sec	

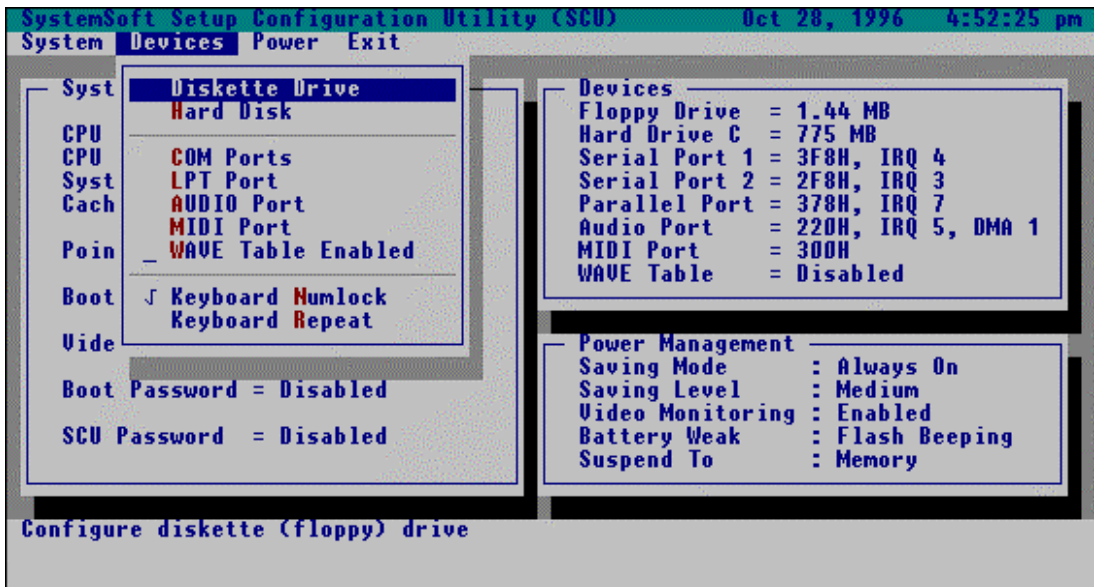





## Power Menu

Clicking an option will **enable** the specific capability.

Item	Setting		Function
Power Management	Power saving mode	Disabled	Disables the system's power saving features.
		Battery only	Enables the system's power saving features only during battery operation.
	Power saving level	Always on	Enables the system's power saving features during either battery or AC operation.
		Low power saving	Enables the power saving to its lowest which results in maximum performance but shortest battery life.
		Medium power saving	Enables the power saving to its medium which results in moderate performance and battery life.
		High power saving	Enables the power saving to its highest which results in minimum performance but longest battery life.
Video Monitoring			Video RAM access will prevent the system from entering a standby mode.
Suspend Controls	Battery weak	Flash beeping	The warning icon flashes on the LCD bar and emits a series of the audio beeps.
		Suspend system	Automatically suspends the system upon a low battery condition.
		Flash only	The warning icon flashes on the LCD bar.
	Suspend mode	Suspend to memory	Specifies the suspend mode as 5-volt suspend mode.
		Suspend to disk	Specifies the suspend mode as 0-volt suspend mode.
	Modem ring resume		
Set resume alarm	Resume hour Resume minute		Sets the time to resume the system from suspend-to-memory mode.

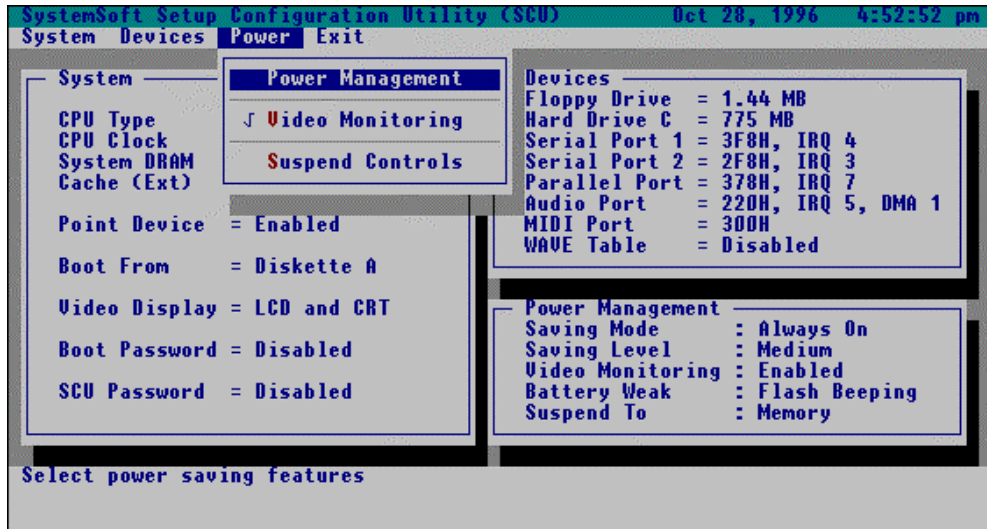

## Exit Menu

Clicking an option will **enable** the specific capability.

Item	Function
Save and Reboot	Saves the current settings and reboots the system.
Exit (No Save)	Exits the SCU without saving any of the current changes.
Default Settings	Changes the current setup to the system default values.
Restore Settings	Restores the current setup to the original custom values.
Version Information	Displays the current BIOS version information.

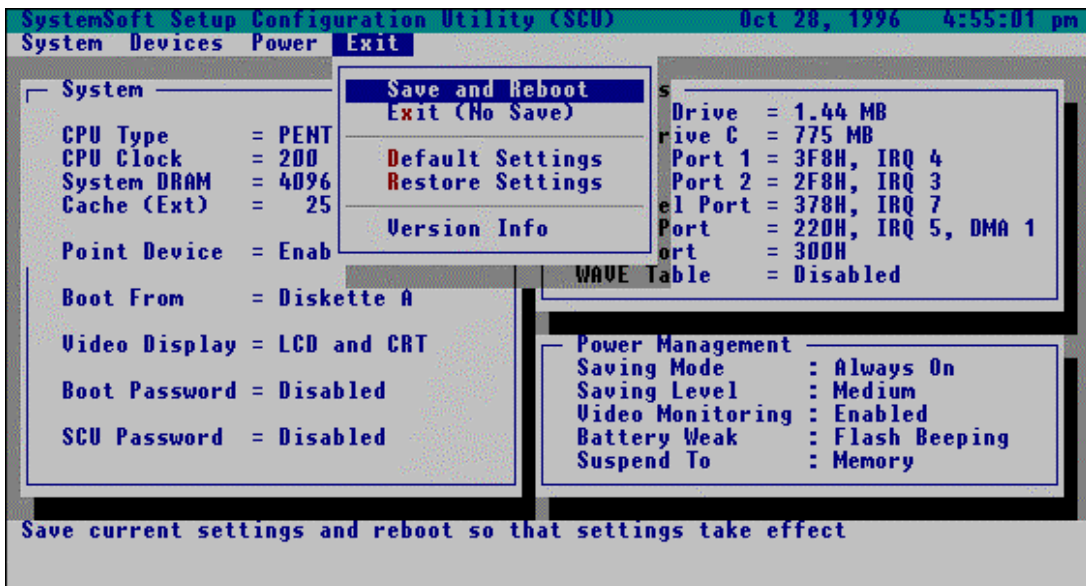

## POST.EQU -- Power On Self-Test Definitions

DEBUG_MISC_RESET	EQU 10H	; Some Type Of Long Reset
DEBUG_CS_FAST_A20_RESET	EQU 11H	; Turn off FASTA20 for POST
DEBUG_POST_SIGNAL_POR	EQU 12H	; Signal Power On Reset
DEBUG_CS_CHIP_INIT	EQU 13H	; Initialize the Chipset
DEBUG_OEM_ISA_VGA_SEARCH	EQU 14H	; Search For ISA Bus VGA Adapter
DEBUG_HWIO_SETUP CTC1	EQU 15H	; Reset Counter/Timer 1
DEBUG_OEM_SET_CMOS_REGS	EQU 16H	; user register config through CMOS
DEBUG_CS_MEMORY_SIZE	EQU 17H	; Size Memory
DEBUG_POST_TEST_RAM	EQU 18H	; Dispatch To RAM Test
DEBUG_GEN_TEST_ROMS	EQU 19H	; checksum the ROM
DEBUG_HWIO_RESET_INTS	EQU 1AH	; Reset PIC's
DEBUG_VIDEO_VIDEO_INIT	EQU 1BH	; Initialize Video Adapter(s)
DEBUG_VIDEO_EQUIP_INIT	EQU 1CH	; Initialize Video (6845 Regs)
DEBUG_VIDEO_COLOR_INIT	EQU 1DH	; Initialize Color Adapter
DEBUG_VIDEO_BW_INIT	EQU 1EH	; Initialize Monochrome Adapter
DEBUG_HWIO_TEST_DMA_PAGE	EQU 1FH	; Test 8237A Page Registers
DEBUG_KEYB_SELFTEST_CTLR	EQU 20H	; Test Keyboard
DEBUG_KEYB_RESET_KEYBOARD	EQU 21H	; Test Keyboard Controller
DEBUG_POST_CHECK_CMOS_RAM	EQU 22H	; Check If CMOS Ram Valid
DEBUG_POST_TEST_BATT_CMOS_SUM	EQU 23H	; Test Battery Fail & CMOS X-SUM
DEBUG_HWIO_TEST_DMA_CTLRS	EQU 24H	; Test the DMA controllers
DEBUG_HWIO_INIT_8237	EQU 25H	; Initialize 8237A Controller
DEBUG_POST_INIT_VECS	EQU 26H	; Initialize Int Vectors
DEBUG_RAM_QUICK_SIZE	EQU 27H	; RAM Quick Sizing
DEBUG_RAM_PROT_ENTRY_1	EQU 28H	; Protected mode entered safely
DEBUG_RAM_SIZE_DONE	EQU 29H	; RAM test completed
DEBUG_RAM_PROT_EXIT	EQU 2AH	; Protected mode exit successful
DEBUG_CS_SHADOW_SETUP	EQU 2BH	; Setup Shadow
DEBUG_VIDEO_EQUIP_INIT_INIT	EQU 2CH	; Going To Initialize Video
DEBUG_VIDEO_BW_SEARCH	EQU 2DH	; Search For Monochrome Adapter
DEBUG_VIDEO_COLOR_SEARCH	EQU 2EH	; Search For Color Adapter
DEBUG_VIDEO_SIGNON	EQU 2FH	; Signon messages displayed
DEBUG_OEM_CONFIG_KBD_CTL	EQU 30H	; special init of keyboard ctr
DEBUG_KEYB_PRESENT_TEST	EQU 31H	; Test If Keyboard Present
DEBUG_KEYB_TEST_IRQ1	EQU 32H	; Test Keyboard Interrupt
DEBUG_KEYB_TEST_CMD	EQU 33H	; Test Keyboard Command Byte
DEBUG_RAM_FULL_TEST	EQU 34H	; TEST, Blank and count all RAM
DEBUG_RAM_PROT_ENTRY_2	EQU 35H	; Protected mode entered safely (2).
DEBUG_RAM_TEST_DONE	EQU 36H	; RAM test complete
DEBUG_RAM_PROT_EXIT_2	EQU 37H	; Protected mode exit successful
DEBUG_KEYB_OUTPUT_PORT	EQU 38H	; Update OUTPUT port
DEBUG_CS_CACHE_SETUP	EQU 39H	; Setup Cache Controller
DEBUG_HWIO_TEST_PERIODIC	EQU 3AH	; Test If 18.2Hz Periodic Working
DEBUG_GEN_CHECK_RTC	EQU 3BH	; test for RTC ticking
DEBUG_GEN_INIT_HARD_VECS	EQU 3CH	; initialize the hardware vectors
DEBUG_MOUSE_INIT	EQU 3DH	; Search and Init the Mouse
DEBUG_KEYB_SET_LEDS_1	EQU 3EH	; Update NUMLOCK status
DEBUG_OEM_DEVICE_CONFIG	EQU 3FH	; special init of COMM and LPT ports
DEBUG_CS_CONFIG_PORTS	EQU 40H	; Configure the COMM and LPT ports
DEBUG_FLOP_INIT	EQU 41H	; Initialize the floppies
DEBUG_WINI_INIT	EQU 42H	; Initialize the hard disk
DEBUG_HWIO_ROM_INIT	EQU 43H	; Initialize option ROMs
DEBUG_OEM_INIT_POWER_MAN	EQU 44H	; OEM's init of power management
DEBUG_KEYB_SET_LEDS_2	EQU 45H	; Update NUMLOCK status
DEBUG_HWIO_FIND_80X87	EQU 46H	; Test For Coprocessor Installed
DEBUG_OEM_LAST_MINUTE_INIT	EQU 47H	; OEM functions before boot
DEBUG_MISC_LAUNCH_INT19	EQU 48H	; Dispatch To Op. Sys. Boot

DEBUG\_BEGIN\_BOOT\_CODE EQU 49H ; Jump Into Bootstrap Code

DEBUG\_CDROM\_INIT EQU 0FAh ; Initialize CD-ROM Type

DEBUG\_S2D\_INIT EQU 0FBh ; Initialize S2D Partition

## DEBUG codes for PNP BIOS

DEBUG\_PNP\_ENABLE\_VERIFY\_RTDATA EQU 0A1H ;Enable/Verify R/W Status Runtime Data Area

DEBUG\_PNP\_GET\_VERIFY\_NVRAM EQU 0A2H ;Get/Verrify R/W Status NVRAM data area

DEBUG\_PNP\_SYSTEM\_NODES EQU 0A3H ;Resolve System Nodes with the CMOS settings

DEBUG\_PNP\_INITIALIZE\_RTDATA EQU 0A4H ;Init. var. in the PNP BIOS Runtime Data area

DEBUG\_PNP\_HOOK\_INT15 EQU 0A5H ; Hook INT 15

DEBUG\_PNP\_SET\_COPY\_AREA EQU 0A6H ;copy/setup \$PnP Install Check in F000 seg.

DEBUG\_PNP\_OEM\_LATE\_HOOK EQU 0A7H ; Allow the OEM any Last Minute Hooks

DEBUG\_PNP\_WRITE\_PROTECT\_RT\_DATA EQU 0A8H ;Write protect RTData Area & NVRAM Copy Buffer

DEBUG\_PNP\_INIT\_RETURN EQU 0A9H ;return from pnp\_init proc

## DEBUG codes for the PCI BIOS

DEBUG\_ROM\_MAPPED\_OK EQU 0D0H ;check rom signature, 1.x video

DEBUG\_SEGMENTENABLE\_COPYSTATE\_1 EQU 0D1H ;enable RAM area in regs

DEBUG\_COPY\_HROM\_RAM\_1 EQU 0D2H ;copy ROM to RAM in regs

DEBUG\_SEGMENTENABLE\_READWRITE\_1 EQU 0D3H ;update segment range attr

DEBUG\_MAP\_MEM\_1 EQU 0D4H ;configure memory registers

DEBUG\_MAP\_IO\_1 EQU 0D5H ;configure I/O registers

DEBUG\_MAP\_IRQ\_1 EQU 0D6H ;configure IRQ assignments

DEBUG\_CONFIG\_COM\_REG\_1 EQU 0D7H ;turn on PCI device

DEBUG\_REVISION\_1 EQU 0D8H ;2.x video r/w segment

DEBUG\_OEM\_DEV\_CLEANUP\_1 EQU 0D9H ;OEM defined, rom init

DEBUG\_PCI\_ADDIN\_ROM\_DISABLE\_1 EQU 0DAH ;disable add-in rom card decode

DEBUG\_RET\_PCI\_1 EQU 0DBH ;PCI return(config and no video)

DEBUG\_SEGMENTENABLE\_COPYSTATE\_2 EQU 0DCH ;enable RAM area in regs

DEBUG\_COPY\_HROM\_RAM\_2 EQU 0DDH ;copy ROM to RAM in regs

DEBUG\_SEGMENTENABLE\_READWRITE\_2 EQU 0DEH ;update segment range attr

DEBUG\_MAP\_MEM\_2 EQU 0DFH ;configure memory registers

DEBUG\_MAP\_IO\_2 EQU 0E0H ;configure I/O registers

DEBUG\_MAP\_IRQ\_2 EQU 0E1H ;configure IRQ assignments

DEBUG\_CONFIG\_COM\_REG\_2 EQU 0E2H ;turn on PCI device

DEBUG\_REVISION\_2 EQU 0E3H ;2.x video r/w segment

DEBUG\_OEM\_DEV\_CLEANUP\_2 EQU 0E4H ;OEM defined, rom init

DEBUG\_PCI\_ADDIN\_ROM\_DISABLE\_2 EQU 0E5H ;disable add-in rom card decode

DEBUG\_RET\_PCI\_2 EQU 0E6H ;PCI return(config and no video)

DEBUG\_BRIDGE\_HUNT EQU 0E7H ;look for PCI bridge device

DEBUG\_PCI\_IDE\_FIND EQU 0E8H ;search IDE controllers on the PCI bus

## Error Codes returned by APM sub-functions

errPM_Disabled	EQU	01H	;PM functionality is disabled
errInterf_Present	EQU	02H	;Interface already present
errInterf_Not_Present	EQU	03H	;Interface disconnected or not est.
errPM16_Est	EQU	05H	;Prot. Mode 16-bit already est.
errPM16_Unsupported	EQU	06H	;Prot. Mode 16-bit unsupported
errPM32_Est	EQU	07H	;Prot. Mode 32-bit already est.
errPM32_Unsupported	EQU	08H	;Prot. Mode 32-bit unsupported
errUnrec_Device_ID	EQU	09H	;Unrecognized Device ID
errCX_Parm_OOR	EQU	0AH	;CX Parameter out of range
errInterf_Not_Engaged	EQU	0BH	;Interface not engaged (APM 1.1)
errCant_Enter_State	EQU	60H	;Can not enter requested state
errNo_PM_Pending	EQU	80H	;No PM Events pending
errAPM_Not_Present	EQU	86H	;Advanced Power Management not present
errUnsupported_APM_Fn	EQU	0FFH	;SystemSoft internal define
errPM_already_enabled	EQU	30h	; PM is already enabled
errPM_already_disabled	EQU	31h	; PM is already disabled
errPM_function_not_supp	EQU	32h	; PM function not supported
DIAG	EQU	1	
APM_INST	EQU	0D0h	
APM_INTF_CONNECT	EQU	0D1h	
APM_PM16_CON	EQU	0D2h	
APM_PM32_CON	EQU	0D3h	
APM_INTF_DISCON	EQU	0D4h	
APM_CPUIDLE	EQU	0D5h	
APM_CPUBUSY	EQU	0D6h	
APM_POWER	EQU	0D7h	
APM_EN_DIS_PM	EQU	0D8h	
APM_DEFAULTS	EQU	0D9h	
APM_GET_STATUS	EQU	0DAh	
APM_HAVE_EVENT	EQU	0DBh	
APM_EVENT_CALL	EQU	0DCh	
APM_TRIGGER	EQU	0DDh	
SMI_TRIGGER	EQU	0DDh	
APM_GET_PM_ENABLE	EQU	0DEH	

# *Chapter 3: Technical View*

## **Overview**

This chapter outlines the architecture of the Notebook Computer. The purpose of this chapter is not to elaborate upon the internal working theories of the components that make up the Notebook Computer, but to explain all the features that these chips offer though may not necessarily supported by the system. This chapter is divided into the followings for discussion:

- ☞ System Block Diagram.

- ☞ Chips.

- Core logic.
- I/O.
- PCMCIA.
- Audio.
- Video.

- ☞ Accessories.

- Battery.
- CD-ROM.
- Floppy disk drive.
- LCD panel.





# Chips

The following chips have been implemented in the Notebook Computer to interface the microprocessors to I/O devices and memory chips.

- SiS5101 PCI Cache Memory Controller.
- SiS5102 PCI Local Data Buffer.
- SiS5103 System I/O & PMU.
- SMC FDC37C669FR PC95/96 Compatible Super I/O Floppy Disk Controller with Infrared Support.
- Omega 82C094 PCI-to-PCMCIA Host Adapter Controller.
- ESS ES1788 AudioDrive.
- ESS ES690 Wave Table Music Synthesizer.
- ESS ES981 Wavetable Sample Set ROM.
- Trident Cyber9385 Flat Panel Controller for PCI systems.

## SiS5101 PCI Cache Memory Controller

- Supports Pentium, K5 and M1 processors.
- Integrated Second Level (L2) Cache Controller.
  - \* Write through and write back cache modes.
  - \* 8 bits or 7 bits tag with Direct Mapped Organization.
  - \* Supports standard and burst SRAMs.
  - \* Supports SRAM standard mode.
  - \* Supports 64 Kbytes to 2 Mbytes cache sizes.
  - \* Cache read/write cycle of 3-2-2-2 or 4-2-2-2 using standard SRAMs at 66MHz.
  - \* Cache read/write cycle of 3-1-1-1 using burst SRAMs at 66MHz.
- Integrated DRAM controller.
  - \* Supports 4 banks of SIMMs up to 256 Mbytes of cacheable main memory.
  - \* Supports “table-free” DRAM configuration.
  - \* Concurrent write back.
  - \* CAS#-before-RAS# transparent DRAM refresh.
  - \* Supports 256K/512K/1M/2M/4M/8M/16MxN 70ns Fast Page Mode and EDO DRAM.
  - \* The fastest burst cycle speed for FP and EDO are 6-3-3-3 and 6-2-2-2 respectively.
  - \* Programmable CAS# driving current.
  - \* Programmable DRAM speed.
  - \* Supports slow refresh.
- Two programmable non-cacheable regions.
- Supports synchronous and asynchronous PCI clock.
- Supports SMI/SMM mode.
- Supports CPU stop clock.
- Provides high performance PCI arbiter.
  - \* Supports four PCI masters.
  - \* Supports rotating priority mechanism.
  - \* Hidden arbitration scheme minimizes arbitration overhead.
- Integrated PCI bridge.
  - \* Translates the CPU cycles into the PCI bus cycles.
  - \* Provides CPU-to-PCI read assembly and write disassembly mechanism.
  - \* Translates sequential CPU-to-PCI memory write cycles into PCI burst cycles.
  - \* PCI burst write in the pace of X-2-2-2...
  - \* PCI burst read L2 cache in X-2-2-2...
  - \* PCI burst read DRAM in X-3-2-3-2...
  - \* Cache snoop filters ensure data coherency and minimizes snoop frequency.
  - \* meet PCI specification buffer strength.
- Supports Leakage control.
- Supports suspend to Memory.
- 208-pin PQFP/TQFP package.
- 0.6 $\mu$ m CMOS technology.

## SiS5102 PCI Local Data Buffer

- Supports full 64-bit Pentium processor data bus.
- Provides a 64-bit interface to DRAM memory.
- Provides a 32-bit interface to PCI.
- Three integrated posted write buffers and two read buffers increase system performance.
  - \* 1 level CPU-to-Memory Posted Write Buffer (CTMPB) with 4 QuadWords (QWs) deep.
  - \* 4 level CPU-to-PCI Posted Write Buffer (CTPPB) with 4 DoubleWords (DWs) deep.
  - \* 1 level PCI-to-Memory Posted Write Buffer (PTMPB) with 1 QW deep.
  - \* 1 level Memory-to-CPU Read Buffer (CRMB) with 1 QW deep.
  - \* 1 level Memory-to-PCI Read Buffer (PRMB) with 1 QW deep.
- Near Zero wait state performance on CPU-to-Memory and CPU-to-PCI writes.
- Operates synchronously to the 66.7 MHz CPU and 33.3 MHz PCI clocks.
- Provides parity generation for memory writes.
- 208-pin PQFP.
- 0.6 $\mu$ m CMOS technology.

## SiS5103 System I/O & PMU

- Integrated bridge between PCI bus and ISA bus.
  - \* Translates PCI bus cycles into ISA bus cycles.
  - \* Translates ISA master or DMA cycles into PCI bus cycles.
  - \* Provides PCI-to-ISA memory one Double Word Posted Write Buffer.
- Integrated ISA bus compatible logic.
  - \* ISA bus controller.
  - \* ISA arbiter for ISA master, DMA devices, and refresh.
  - \* Built-in two 8237 compatible DMA controllers.
  - \* Built-in two 8259A compatible interrupt controllers.
  - \* Built-in one 8254 timer.
- Supports reroutability of four PCI interrupts to any unused IRQ interrupt.
- Supports flash ROM.
- Built-in RTC with 242 bytes extended CMOS SRAM.
- Built-in PCI IDE.
  - \* Fully compatible with PCI local bus specification v2.0.
  - \* Accommodates 8 bits, 16 bits, and 32 bits data transfer.
  - \* Supports PCI burst read/write operation.
  - \* Supports read ahead & posted write buffers for concurrent system operation.
  - \* Controls two IDE channels and max. connects 4 IDE drives.
  - \* Supports PIO mode 4 timing proposal on enhanced IDE specifications.
  - \* Programmable command and recovery timing for reads and writes per channel.
  - \* Auto IDE channel speed setting with software driver.
  - \* Hardware and software chip disable capability.
  - \* Supports power down feature.
- Meet PCI specification buffer strength.
- Supports CPU thermal detection.
- Supports CPU throttling and clock slow down.
- Supports software SMI and software stop clock port.
- Supports Microsoft APM spec.
- Supports user register 32-bit.
- External hardware SMI request support.
  - \* EXTSUSP, GPIO[3:0], PIO[6:0], UIP [2:0].
- Supports four Power Management Mode.
  - \* Local auto doze mode.
  - \* Global auto doze mode.
  - \* Standby mode.
  - \* Suspend mode.
- Supports programmable PMU timer.
  - \* Seven sub-doze timer: 31mS/125mS/05.Sec/1Sec/1.5Sec/2Sec/3Sec.
  - \* Standby timer: 4 sec ~ 5 min.
  - \* Suspend time: 1 min ~ 60 min.

- Battery Management
  - \* AC power indicator.
  - \* Multi-level low battery monitor: LB, LLB.
  - \* Battery low SMI generation.
- Supports suspend to hard disk.
  - \* Read only shadow register.
- Supports suspend to memory.
- Supports doze, standby and suspend modes status output pin.
- Supports ISA leakage control.
- Standby/resume toggle switch.
- Standby/resume button switch.
- Modem ring/GPIO wake up.
- Supports hot docking.
- 208-pin PQFP/TQFP package.
- 0.6 $\mu$ m CMOS technology.

## SMC FDC37C669FR I/O FDD Controller with IR

- 5 volt operation.
- Intelligent auto power management.
- 16 bit address qualification (option).
- 2.88MB super I/O floppy disk controller.
  - \* Licensed CMOS 7658 floppy disk controller.
  - \* Software and register compatible with SMC's proprietary 82077AA compatible core.
  - \* Supports two floppy drives directly.
  - \* Supports vertical recording format.
  - \* 16 byte data FIFO.
  - \* 100% IBM compatibility.
  - \* Detects all overrun and underrun conditions.
  - \* Sophisticated power control circuitry (PCC) including multiple powerdown modes for reduced power consumption.
  - \* DMA enable logic.
  - \* Data rate and drive control registers.
  - \* Swap drives A and B.
  - \* Non-burst mode DMA option.
  - \* 48 base I/O address, 7 IRQ and 3 DMA options.
- Floppy disk available on parallel port pins.
- Enhanced digital data separator.
  - \* 2 Mbps, 1 Mbps, 500 Kbps, 300 Kbps, 250 Kbps data rates.
  - \* Programmable precompensation modes.
- Serial Ports
  - \* Two high speed NS16C550 compatible UARTs with send/receive 16 byte FIFOs.
  - \* Supports 130k and 460k baud.
  - \* Programmable baud rate generator.
  - \* Modem control circuitry.
  - \* Infrared - IrDA, HPSIR, ASKIR, Fast IR (4Mbps IrDA), consumer IR support.
  - \* Alternate IR pins (option).
  - \* 96 base I/O address and 7 IRQ options.
- Multi-Mode parallel port with ChiProtect.
  - \* Standard mode.
  - \* IBM PC/XT, PC/AT and PS/2 compatible bidirection parallel port.
  - \* Enhanced parallel Port (EPP) compatible.
  - \* EPP 1.7 and EPP 1.9 (IEEE 1284 compliant).
  - \* Enhanced Capabilities Port (ECP) compatible (IEEE 1284 compliant).
  - \* Incorporates ChiProtect circuitry for protection against damage due to printer power-on.
  - \* 192 base I/O address, 7 IRQ and 3 DMA options.
- IDE interface (option).
  - \* On-Chip decode and select logic compatible with IBM PC/XT and PC/AT embedded hard disk drives.
  - \* 48 base I/O address and 7 IRQ options.
- Game Port Select Logic
  - \* 48 base I/O address.

- General purpose address decoder.
  - \* 16 byte block decode.
  - \* 48 base I/O address options.
- 100 pin QFP and TQFP package.



# Omega 82C094 PCMCIA Host Adapter Controller

## Small Form Factor

- Single-chip PCMCIA host controller.
- Legacy DMA and serial IRQ to directly support advanced PCI core logic.
- Serial power control to support the designs with most PCMCIA power switch IC.
- Direct connection to 33Mhz PCI bus and two PCMCIA sockets without glue logic.
- 208 pin PQFP or TQFP.

## Compatibility

- Compliant with PC Card 95, PCMCIA 2.1, and JEIDA 4.1, ExCA.
- Register-set compatible to Intel i82092AA (PPEC) and Intel i82365SL.

## Power Management

- Supports CLOCKRUN# of the PCI mobile design guide for power saving.
- Intelligent power management for lowest operation power.
- Programmable power management with individual socket activity counter.

## High Performance

- Four-level FIFO and programmable PCMCIA interface timing.
- Five programmable memory windows and two programmable I/O windows per socket.

## **ESS ES1788 AudioDrive**

The ES1788 AudioDrive can record, compress, and playback voice, sound and music with built-in mixer controls. It consists of an embedded microprocessor, a game compatible 16-bit stereo A/D and D/A, music 16-bit stereo D/A, 20-voice 72 operator FM music synthesizer, MIDI serial port compatible with MPU401 UART mode, dual joystick timers, hardware volume control, DMA control, and ISA bus interface logic. A DSP serial interface allows an external DSP to take over analog resources such as the D/A or A/D converters. Control of I/O address, DMA, and interrupt selection is controlled by system software. Interface to analog inputs is extremely simple. There are stereo inputs for CD-audio, line-in, and an external music synthesis chip or TV, and a mono microphone input to an internal pre-amp. A digital PC speaker input is converted to an analog signal with volume control and is available as an analog output signal. Advanced power management features such as suspend/resume to disk, self timed power down, auto-wakeup, and partial power-down are supported. The ES1788 AudioDrive has a 6 bit master volume control with 64 total steps.

The ES1788 AudioDrive is compatible with Sound Blaster PRO version 3.01 voice and music functions as documented in the Sound Blaster Series Developer Kit.

## ESS ES690

- 32 voices.
- General MIDI instrument set - 128 melodic and 47 percussion.
- Chorus and reverb effects.
- Integrated general MIDI interrupt.
- MIDI serial interface.
- Supports 512Kx16 up to 8Mx16 ROM's.
- No DAC required.
- Context upload for suspend/resume to disk.
- Automatic power-down when MIDI input is idle.
- 52 pin PQFP.

## **ESS ES981 Wavetable Sample Set ROM**

- 512Kx16 bit CMOS ROM.
- General MIDI instrument set - 128 melodic and 47 percussion.
- Single +5V power supply.
- 150 ns fast access time.
- Total static operation.
- Operating current 60 mA.
- 44 pin small outline package (SOP).

## **Trident Cyber9385 Flat Panel Controller**

The Cyber9385 is a DRAM based, fully integrated LCD, CRT & TV 64 bit multimedia flat panel controller for PCI systems. It provides a flexible, high performance solution for various color depths and solutions. It supports these displays with options for 1, 1.5, 2 and 4 MB, and allows many memory configurations including unified or shared frame buffer architectures. With burst PCI, Extended Data Out (EDO)/Fast Page Mode (FPM) memory support, and the fastest video graphics engine, the Cyber9385 brings VisualReality to PCs.

### **Highly Integrated Design**

The highly integrated design of the Cyber9385 offers a “no TTL” solution for cost-effective, high performance multimedia subsystem designs for the IBM PC and compatible notebooks. The 64 bit memory data bus, supporting EDO DRAM memory, provides faster data rates for improved system throughput.

## Standard Video Modes

Mode #	Resolution/ Colors	Pixel Freq	Hor Freq	Vert Freq	MEM	Addr	Text Res	Font	Type	Feature
0H, 1H	320x200-16	28	31.4	70	All	B800	40x25	8x8	Text	NI,N,P
2H, 3H	640x200-16	28	31.4	70	All	B800	80x25	8x8	Text	NI,N,P
4H, 5H	320x200-4	25	31.4	70	All	B800	40x25	8x8	Graphic	NI,N,P
6H	640x200-2	25	31.4	70	All	B800	80x25	8x8	Graphic	NI,N,P
7H	720x350-Mono	28	31.4	70	All	B000	80x25	9x14	Text	NI,N,P
DH	320x200-16	25	31.4	70	All	A000	40x25	8x8	Graphic	NI,N,P
EH	640x200-16	25	31.4	70	All	A000	80x25	8x8	Graphic	NI,N,P
10H	640x350-16	25	31.4	70	All	A000	80x25	8x14	Graphic	NI,N,P
11H	640x480-2	25	31.4	60	All	A000	80x30	8x16	Graphic	NI,N,P
12H	640x480-16	25	31.4	60	All	A000	80x30	8x16	Graphic	NI,N,P
13H	320x200-256	25	31.4	70	All	A000	40x25	8x8	Graphic	NI,N,P

1. NI = Non-Interlaced VGA display
2. I = Interlaced VGA display
3. N = NTSC TV display (VGA monitor and TV display switching)
4. P = PAL TV display (VGA monitor and TV display switching)

## Extended Video Modes

Mode #	Resolution/ Colors	Pixel Freq	Hor Freq	Vert Freq	MEM	Addr	Text Res	Font	Type	Feature
50H	640X480-16	25	31.5	60	All	D800	80X30	8x16	Text	NI,N,P
51H	640X473-16	25	31.5	60	All	D800	80X43	8x8	Text	NI,N,P
52H	640X480-16	25	31.5	60	All	D800	80X60	8x8	Text	NI,N,P
53H	1056X350-16	40	31.3	70	All	D800	132X25	8x14	Text	NI
54H	1056X480-16	40	31.3	60	All	D800	132X30	8x16	Text	NI
55H	1056X473-16	40	31.3	60	All	D800	132X43	8x8	Text	NI
56H	1056X480-16	40	31.3	60	All	D800	132X60	8x8	Text	NI
57H	1188X350-16	45	31.3	70	512K	D800	132X25	9x14	Text	NI
58H	1188X480-16	45	31.3	60	512K	D800	132X30	9x16	Text	NI
59H	1188X473-16	45	31.3	60	512K	D800	132X43	8x8	Text	NI
5AH	1188X480-16	45	31.3	60	512K	D800	132X60	8x8	Text	NI
5BH_1	800X600-16	40	37.9	60	All	A000	100X75	8x8	Graphic	NI,P
5BH_2	800X600-16	49.5	46.9	75	512K	A000	100X75	8x8	Graphic	NI,P
5BH_3	800X600-16	56.3	53.7	85	512K	A000	100X75	8x8	Graphic	NI,P
5CH	640X400-256	25	31.6	70	1M	A000	80X25	8x16	Graphic	NI,N,P
5DH_1	640X480-256	25	31.5	75	512K	A000	80X30	8x16	Graphic	NI,N,P
5DH_2	640X480-256	31.5	37.9	72	512K	A000	80X30	8x16	Graphic	NI,N,P
5DH_3	640X480-256	31.5	37.5	75	512K	D800	80X60	8x16	Graphic	NI
5DH_4	640X480-256	36	43.3	85	512K	D800	80X60	8x16	Graphic	NI
5EH_1	800X600-256	40	37.9	60	512K	A000	100X37	8x16	Graphic	NI,P
5EH_2	800X600-256	49.5	46.9	75	512K	A000	100X37	8x16	Graphic	NI,P
5EH_3	800X600-256	56.3	53.7	85	512K	A000	100X37	8x16	Graphic	NI,P
5FH_1	1024X768-16	45	35.5	87I	512K	A000	128X48	8x16	Graphic	I
5FH_2	1024X768-16	65	48.5	60	512K	A000	128X48	8x16	Graphic	NI
5FH_3	1024X768-16	75	56.5	70	512K	A000	128X48	8x16	Graphic	NI
5FH_4	1024X768-16	78.8	60	75	512K	A000	128X48	8x16	Graphic	NI
60H	1024X768-16	45	35.7	87I	512K	A000	128X48	8x16	Graphic	I
62H_1	1024X768-256	45	35.5	87I	1M	A000	128X48	8x16	Graphic	I
62H_2	1024X768-256	65	48.5	60	1M	A000	128X48	8x16	Graphic	NI
62H_3	1024X768-256	75	56.5	70	1M	A000	128X48	8x16	Graphic	NI
62H_4	1024X768-256	80	59.5	75	1M	A000	128X48	8x16	Graphic	NI
63H_1	1280X1024-16	75	46.9	87I	1M	A000	160X64	8x16	Graphic	I
63H_2	1280X1024-16	108	63.0	60	1M	A000	160X64	8x16	Graphic	NI
63H_3	1280X1024-16	135	80	75	1M	A000	160X64	8x16	Graphic	NI
64H_1	1280X1024-256	75	46.9	87I	2M	A000	160X64	8x16	Graphic	I
64H_2	1280X1024-256	108	63.0	60	2M	A000	160X64	8x16	Graphic	NI
64H_3	1280X1024-256	67.5	80.0	75	2M	A000	160X64	8x16	Graphic	NI
64H_4	1280X1024-256	135	80.0	75	2M	A000	160X64	8x16	Graphic	NI
65H_1	1600X1200-16Ci	135	62.5	96I	1M	A000	200X75	8x16	Graphic	I
66H_1	1600X1200-256Ci	67.5	62.5	96I	2M	A000	200X75	8x16	Graphic	I
6AH_1	800x600-16	40	35.2	60	All	A000	100X75	8x16	Graphic	NI,P
6BH	320x200-16M	40	31.6	70	512K	A000	40X25	8x16	Graphic	NI,N,P
6CH_0	640x480-T	75	31.4	60	1M	A000	80X30	8x16	Graphic	NI,N,P
6CH_1	640x480-T	25	31.5	60	1M	A000	80X30	8x16	Graphic	NI,N,P
6CH_2	640x480-T	31.5	37.9	72	1M	A000	80X30	8x16	Graphic	NI,N,P
6CH_3	640x480-T	31.5	37.5	75	1M	A000	80X30	8x16	Graphic	NI,N,P
6CH_4	640x480-T	36	43.3	85	1M	A000	80X30	8x16	Graphic	NI
6DH_1	800x600-T	40	37.9	60	2M	A000	100X37	8x16	Graphic	NI,P
6DH_2	800x600-T	49.5	46.9	75	2M	A000	100X37	8x16	Graphic	NI,P
6EH_1	1024x768-T	45	35.5	87I	4M	A000	128X48	8x16	Graphic	I
6EH_2	1024x768-T	65	48.4	60	4M	A000	128X48	8x16	Graphic	NI
74H_1	640x480-32K	50	31.4	60	1M	A000	80X30	8x16	Graphic	NI,N,P
74H_2	640x480-32K	65	40.1	72	1M	A000	80X30	8x16	Graphic	NI,N,P
74H_3	640x480-32K	31.5	37.5	75	1M	A000	80X30	8x16	Graphic	NI,N,P
74H_4	640x480-32K	36	43.3	85	1M	A000	80X30	8x16	Graphic	NI,N,P
75H_1	640x480-64K	50	31.4	60	1M	A000	80X30	8x16	Graphic	NI,N,P
75H_2	640x480-64K	65	40.1	72	1M	A000	80X30	8x16	Graphic	NI,N,P

75H_3	640x480-64K	31.5	37.5	75	1M	A000	80X30	8x16	Graphic	NI,N,P
75H_4	640x480-64K	36	43.3	85	1M	A000	80X30	8x16	Graphic	NI,N,P
76H_1	800x600-32K	40	37.9	60	1M	A000	100X37	8x16	Graphic	NI,P
76H_2	800x600-32K	40	37.9	60	1M	A000	100X37	8x16	Graphic	NI,P
76H_3	800x600-32K	49.5	46.9	75	1M	A000	100X37	8x16	Graphic	NI,P



Mode #	Resolution/ Colors	Pixel Freq	Hor Freq	Vert Freq	MEM	Addr	Text Res	Font	Type	Feature
77H_1	800x600-64K	40	37.9	60	1M	A000	100X3 7	8x16	Graphic	NI,P
77H_2	800x600-64K	49.5	46.9	75	1M	A000	100X3 7	8x16	Graphic	NI,P
77H_3	800x600-64K	56.3	53.7	85	1M	A000	100X3 7	8x16	Graphic	NI,P
78H_1	1024x768-32K	44.9	35.5	87I	2M	A000	128X4 8	8x16	Graphic	I
78H_2	1024x768-32K	65	48.4	60	2M	A000	128X4 8	8x16	Graphic	I
78H_3	1024x768-32K	78	60.0	75	2M	A000	128X4 8	8x16	Graphic	NI
79H_1	1024x768-64K	44.9	35.5	87I	2M	A000	128X4 8	8x16	Graphic	I
79H_2	1024x768-64K	65	48.4	60	2M	A000	128X4 8	8x16	Graphic	I
79H_3	1024x768-64K	78	60.0	75	2M	A000	128X4 8	8x16	Graphic	NI
7AH_1	1280x1024-32K	78	46.4	87I	4M	A000	160X6 4	8x16	Graphic	I
7BH_1	1280x1024-64K	78	46.4	87I	4M	A000	160X6 4	8x16	Graphic	I

## Video Mode Cross Reference

Resolution X*Y	Color Depth Bit	Refresh Rate Hz	Scan Order I/NI	Video Clock Frequency MHz	Memory Clock Frequency MHz	Minimum DRAM MB	Acceleration Scheme V/A/H
640x480	4	60	NI	25.175	58.000	½	V
640x480	4	75	NI	31.500	58.000	½	V
640x480	8	60	NI	25.175	58.000	½	A
640x480	8	75	NI	31.500	58.000	½	A
640x480	15/16	60	NI	25.175	58.000	1	A
640x480	15/16	75	NI	31.500	58.000	1	A
640x480	24	60	NI	25.175	58.000	1	H
640x480	24	75	NI	31.500	58.000	1	H
800x600	4	60	NI	40.000	58.000	½	V
800x600	4	75	NI	49.500	58.000	½	V
800x600	8	60	NI	40.000	58.000	½	A
800x600	8	75	NI	49.500	58.000	½	A
800x600	8	60	NI	40.000	58.000	1	A
800x600	8	75	NI	49.500	58.000	1	A
800x600	15/16	60	NI	40.000	58.000	1	A
800x600	15/16	75	NI	49.500	58.000	1	A
800x600	15/16	60	NI	40.000	58.000	2	A
800x600	15/16	75	NI	49.500	58.000	2	A
1024x768	4	60	NI	65.000	58.000	½	V
1024x768	4	75	NI	78.750	58.000	½	V
1024x768	8	60	NI	65.000	58.000	1	A
1024x768	8	75	NI	78.750	58.000	1	A
1024x768	15/16	43	I	44.9	58.000	2	A
1280x1024	4	43	I	75.000	58.000	1	V
1280x1024	4	60	NI	108.00	58.000	1	V
1280x1024	8	43	I	75.000	58.000	2	A
1280x1024	8	60	NI	108.00	75.000	2	A

# Accessories

## Battery Pack

### Toshiba Ni-MH Rechargeable Battery

Item		Specifications
Type		10TH-3000AEG
Nominal Voltage		1.2V
Nominal Capacity		3000mAh
Standard Charging		0.1C mA x 15 hours
Fast Charging		Maximum 1.0 CmA
Standard Discharge Current		0.2 CmA
Maximum Discharge Current		1.5 CmA
Discharge Final Voltage		1.0 V
Operating Temperature	Standard Charging	0 ~ +45°C
	Fast Charging	+5 ~ +45°C
	Discharge	-20 ~ +60°C
	Storage	3-12 months
within 3 months		-20 ~ +35°C
Weight		52 grams

### Duracell DR36S (Available at Worldwide Retailers)

Item		Specifications
Type		DR36S
Size		10 x 4/3A
Nominal Voltage		12V
Typical Battery Capacity		2.8 Ah
Typical Cell Capacity		3.02 Ah
Minimum Cell Capacity		2.8 Ah
Typical Energy		35 Wh
Maximum Internal Impedance		330 mΩ
Operating Temperature Range	Charge	0°C to 45°C
	Discharge	-20°C to 50°C
Maximum Continuous Current	Charge	1C (2.8A)
	Discharge	1C (2.8A)
Typical Weight		604g
Maximum Volume		258 cm <sup>3</sup>
Terminals		5 position Advanced Interconnect

# CD-ROM

## TEAC CD-46E-900 CD-ROM

Average Random Access Time	190msec average (6X speed)	
Full stroke Access Time	450msec average (6X speed)	
Disk Speed	Inner circumstance	3,180rpm
	Outer circumstance	1,200rpm
Data Transfer Rate	Average sustained	900KB/sec
	Programmed I/O	16.7MB/sec. Max. (Mode 0~4)
	Multi-word DMA	16.7MB/sec. Max. (Mode 0~2)
Starting Time	8sec. Typical, 32sec max.	
Data Buffer Capacity	128KB	
Applicable Discs	CD-DA	
	CD-ROM Mode 1, Mode 2	
	CD-ROM XA Mode 2 (Form 1, Form 2)	
	Photo CD (single/multi-session)	
Dimensions	Height	17.0mm
	Width	130.6mm
	Depth	140.5mm (excluding eject button)
Weight	320g or less	

## TEAC CD-36E-900 CD-ROM

Average Random Access Time	230msec average (6X speed)	
Full stroke Access Time	480msec average (6X speed)	
Disk Speed (at 6X speed)	Inner circumstance	3,180rpm
	Outer circumstance	1,200rpm
Data Transfer Rate	Average sustained	900kB/sec (at 6X speed)
	Programmed I/O	13.3 MB/sec max. (Mode 0~3)
	Multi-word DMA	13.3 MB/sec max. (Mode 0~1)
Starting Time	8sec. Average (when power on or disk loaded)	
Return Time from Standby Mode	2sec or less	
Data Buffer Capacity Applicable Discs	128KB	
	CD-DA	
	CD-ROM Mode 1, Mode 2	
	CD-ROM XA Mode 2 (Form 1, Form 2)	
	Photo CD (single/multi-session)	
	Enhanced CD	
Dimensions	Height	13.7mm
	Width	130.5mm
	Depth	140.5mm(excluding eject button)
Weight	250g or less	

## TEAC CD-38E-900 CD-ROM

Average Random Access Time	200msec average (8X speed)	
Full stroke Access Time	470msec average (8X speed)	
Disk Speed (at sextuple speed)	Inner circumstance	4,240rpm
	Outer circumstance	1,600rpm
Data Transfer Rate	Average sustained	1,200kB/sec
	Programmed I/O	16.7MB/sec max. (mode 0-4)
	Multi-word DMA	16.7MB/sec max. (mode 0-2)
Starting Time	8sec. Average (when power on or disk loaded)	
Return Time from Standby Mode	2sec or less	
Data Buffer Capacity Applicable Discs	128KB	
	CD-DA	
	CD-ROM Mode 1, Mode 2	
	CD-ROM XA Mode 2 (Form 1, Form 2)	
	Photo CD (single/multi-session)	
	Enhanced CD	
Dimensions	Height	13.7mm
	Width	130.5mm
	Depth	140.5mm (excluding eject button)
Weight	250g or less	

## 3.5" Floppy Disk Drive

### Panasonic JU-226A03F FDD

Capacity (in bytes)	Normal Density	High Density	
	(MFM)	(MFM)	(MFM)
Unformatted			
Per Disk	1,000,000	1,666,666	2,000,000
Per Surface	500,000	833,333	1,000,000
Per Track	6,250	10,416	125,000
Formatted (16 sectors/track, 32 sectors/track)			
Per Disk	655,360		1,310,720
Per Track	4,096		8,192
Per Sector	256		256
Formatted (9 sectors/track, 18 sectors/track)			
Per Disk	737,280		1,474,560
Per Track	4,608		9,216
Per Sector	512		512
Formatted (15 sectors/track)			
Per Disk		1,228,800	
Per Track		7,680	
Per Sector		512	
<b>Transfer Rate</b>	250 kbits/s	500 kbits/s	500 kbits/s
<b>Latency (avg.)</b>	100 ms	83 ms	100 ms
<b>Access Time</b>			
Track to Track	3 ms	3 ms	3 ms
Average (including settling and latency)	194 ms	177 ms	194 ms
Settling Time	15 ms	15 ms	15 ms
Minimum Turn Around Delay	18 ms	18 ms	18 ms
<b>Motor Start Time</b>	500 ms	500 ms	500 ms
<b>Motor Rotation Select Delay</b>	500 ms	500 ms	500 ms
<b>Dimensions (including front panel)</b>			
Width	101.6 mm		
Height	12.7 mm		
Depth	110.0 mm		

## TEAC FD-04HF-1300 FDD

### 2MB Mode

Recording Method			FM	MFM
Data Transfer Rate (k bits/sec)			250	500
Tracks/Disk			160	160
Innermost Track Bit Density (bpi)			8,717	17,434
Innermost Track Flux Density (frpi)			17,434	17,434
Data Capacity	Unformatted	K bytes/track	6.25	12.50
		K bytes/track	1,000	2,000
	Formatted			
	32 sectors/track	K bytes/track	0.128	0.256
		K bytes/track	4.096	8.192
		K bytes/track	655.36	1,310.72
	18 sectors/track	K bytes/track	0.256	0.512
		K bytes/track	4.608	9.216
		K bytes/track	737.28	1,474.56
	10 sectors/track	K bytes/track	0.512	1.024
		K bytes/track	5.12	10.24
		K bytes/track	819.20	1,638.40

### 1MB Mode

Recording Method			FM	MFM
Data Transfer Rate (k bits/sec)			125	250
Tracks/Disk			160	160
Innermost Track Bit Density (bpi)			4,359	8,717
Innermost Track Flux Density (frpi)			8,717	8,717
Data Capacity	Unformatted	K bytes/track	3.125	6.250
		K bytes/track	500	1,000
	Formatted			
	16 sectors/track	K bytes/track	0.128	0.256
		K bytes/track	2.048	4.096
		K bytes/track	327.68	655.36
	9 sectors/track	K bytes/track	0.256	0.512
		K bytes/track	2.304	4.608
		K bytes/track	368.64	737.28
	5 sectors/track	K bytes/track	0.512	1.024
		K bytes/track	2.560	5.120
		K bytes/track	409.60	819.20

### Physical Specification

Dimension (including front bezel)	Width	101.6 mm
	Height	12.7 mm
	Depth	110 mm



# LCD Panel

## Sanyo LM-JA53-22NTK 12.1" DSTN

Item		Specification
Package dimension		276.5mm(W)x199.0mm(H)x8.0mm(D)
Structure		800(W)xRGB(W)x600(H)
Dot size		0.0871mm(W)x0.2913mm(H)
Dot pitch		0.1021mm(W)x0.3063mm(H)
Bezel opening area		250.0mm(W)x188.5mm(H)
Power supply voltage		Minimum 3.0V
		Maximum 5.5V
Viewing angle range	$\theta=0^\circ$	Minimum $15^\circ$
	$\theta=90^\circ$	Minimum $30^\circ$
	$\theta=180^\circ$	Minimum $20^\circ$
	$\theta=270^\circ$	Minimum $30^\circ$
Contrast ratio ( $\phi=0^\circ$ )		Minimum 15, typical 30
Response time ( $\phi=0^\circ$ )	Rise	Typical 150 ms, maximum 200 ms
	Fall	Typical 150 ms, maximum 200 ms

## Samsung LT104S4-151 10.4" TFT

Item		Specification
Display area		211.2mm(H)x158.4mm(V) (10.4" diagonal)
Number of dots		800x600 pixel
Pixel pitch		0.264mm(H)x0.264mm(W)
Pixel arrangement		RGB vertical stripe
Display colors		262,144 colors
Viewing angle		6 oclcok
Display mode		Normal white
Module size		245.5mm(W)x179.4mm(H)x7.7mm(D)
Weight		400g (max.)
Contrast ratio ( $\theta=0^\circ$ , $\phi=0^\circ$ )		80:1 (min.)
Response time at 25° $\theta=0^\circ$ , $\phi=0^\circ$	Rise	20 (typical)
	Fall	30 (typical)
Luminance		70 cd/m <sup>2</sup> (typical)
Viewing angle	Horizontal-left	45°
	Horizontal-right	45°
	Vertical -high	10°
	Vertical-low	30°
Power supply voltage	Minimum	4.75V
	Typical	5.0V
	Maximum	5.25V

## NEC NL8060AC26-04 10.4" TFT

Item		Specification
Display area		211.2mm(H)x158.4mm(V) (10.4" diagonal)
Drive system		a-Si TFT active matrix
Display colors		262,144 colors
Number of pixel		800x600
Pixel arrangement		RGB vertical stripe
Pixel pitch		0.264mm(H)x0.264mm(V)
Module size		243.0mm(H)x179.0mm(V)x8.0mm(D)
Weight	Typical	410g
Contrast ratio	Typical	150:1
Viewing angle	Horizontal-left	45°
	Horizontal-right	45°
	Vertical-up	25°
	Vertical-down	25°
Viewing direction		12 o'clock (upper direction)
Color gamut		55% (typical center to NTSC)
Response time	Maximum	40ms white to black
Luminance	Typical	70cd/m <sup>2</sup>
Signal system	6-bit digital signals for each of RGB primary colors	
	Synchronous signals (Hsync, Vsync)	
	Dot clock (CLK)	
Supply voltage		3.3V or 5.0V (logic, LCD driving)
Backlight	Edge light type	
	one fluorescent lamp (cold cathode type) inverter-less	

## Hosiden HLD1201-0151XX 12.1" TFT

Item	Specification
Display mode	Normally white mode with positive image (black image, white background)
Viewing direction	Optimum viewing lobe direction is 6 o'clock
Backlight	CCFL edge-light system
Display format	800x600 dots
Screen area	251mmx189.5mm
Color arrangement	RGB vertical stripes
Driving method	6 bits parallel (64 gray levels=262,144 colors)
Interface	3~3.3V CMOS logic
Display outline	278.5mm(w) x 200.5mm(h) x 8.5mm (t) max.
Weight	600 grams
Contrast ratio	70:1 minimum at 25°C $\theta=0^\circ$ , $\phi=0^\circ$ , backlight on
Response time	Tr:28 msec typical, Tf:28 msec typical
Contrast setting	Maximum setting
Brightness (white image)	70 cd/m <sup>2</sup> Typ / If=TBD mA
Surface reflectance	5% max.
Power supply	Minimum 4.75V
	Typical 5V
	Maximum 5.25V

## Samsung LT121S1-103 12.1" TFT

Item		Specification
Display area		246.0mm(H)x184.5mm(V) (12.1" diagonal)
Number of dots		800x600 pixel
Pixel pitch		0.3075mm(H)x0.3075mm(W)
Pixel arrangement		RGB vertical stripe
Display colors		262,144 colors
Viewing angle		6 o'clock
Display mode		Normal white
Module size		275.0mm(W)x200.0mm(H)x8.0mm(D)
Contrast ratio ( $\theta=0^\circ, \phi=0^\circ$ )		80:1 (min.)
Response time at $25^\circ$ $\theta=0^\circ, \phi=0^\circ$	Rise	20 (typical)
	Fall	30 (typical)
Luminance		70 cd/m <sup>2</sup> (typical)
Viewing angle	Horizontal-left	45°
	Horizontal-right	45°
	Vertical -high	10°
	Vertical-low	30°
Power supply voltage	Minimum	3.0V
	Typical	3.3V
	Maximum	3.6V

## NEC NL8060BC31-01 12.1" TFT

Item		Specification
Display area		244.8mm(H)x183.6mm(V) (12.1" diagonal)
Drive system		a-Si TFT active matrix
Display colors		262,144 colors
Number of pixel		800x600
Pixel arrangement		RGB vertical stripe
Pixel pitch		0.306mm(H)x0.306mm(V)
Module size		277.5mm(H)x202.5mm(V)x8.0mm(D) max.
Weight		485g (typical)
Contrast ratio		150:1 (typical)
Viewing angle	Horizontal-left	45°
	Horizontal-right	45°
	Vertical-up	20°
	Vertical-down	35°
Viewing direction	Wider viewing angle with contrast ratio: down side (6 o'clock)	
	Wider viewing angle without image reversal: up side (12 o'clock)	
	Optimum grayscale ( $\gamma=2.2$ ): perpendicular	
Color gamut		42% (typical center to NTSC)
Response time		40ms (max.) white to black
Luminance		70 cd/m <sup>2</sup> (typical) (lamp current 3.0mAms)
Signal system	6-bit digital signals for each of RGB primary colors	
	Synchronous signals (Hsync, Vsync)	
	Dot clock (CLK)	
Supply voltage		3.3V [5.0V] (logic, LCD driving)
Power consumption		3.0W (typical) [at 3.3V]
Backlight	Edge light type one fluorescent lamp (cold cathode type) inverter-less	

# Chapter 4: Parts & Circuit

This chapter provides both the parts list and the circuit diagrams for engineers to maintain the Notebook system.

## Parts List.

- Top Case & Assemblies.
- Bottom Case & Assemblies.
- Display Panel & Assemblies.
- CD-ROM.
- Floppy Disk Drive.
- Hard Disk Drive.
- Second Battery.

## Circuit Diagrams.

- Mainboard. 77-62000-D03
- DC/DC. 77-6200C-D03
- LCD Bar. 77-62006-D01
- Switch Board. 77-6200S-D02
- 8/16MB Memory. 77-6202T-D71
- 32MB Memory. 77-2205T-060
- 40MB Memory. 77-2205T-A61
- 3.3V Power. 77-620A5-D10
- 3.1V/2.9V Power. 77-620A5-D31
- Panel Data.
  - ☞ DSTN 12.1" Sanyo 77-6200Z-D01
  - ☞ TFT 10.4" NEC 77-6220Z-D11
  - ☞ TFT 10.4" Samsung 77-6220Z-D21
  - ☞ TFT 12.1" NEC/Samsung 77-6220Z-D02
  - ☞ TFT 12.1" Hosiden 77-6220Z-D30







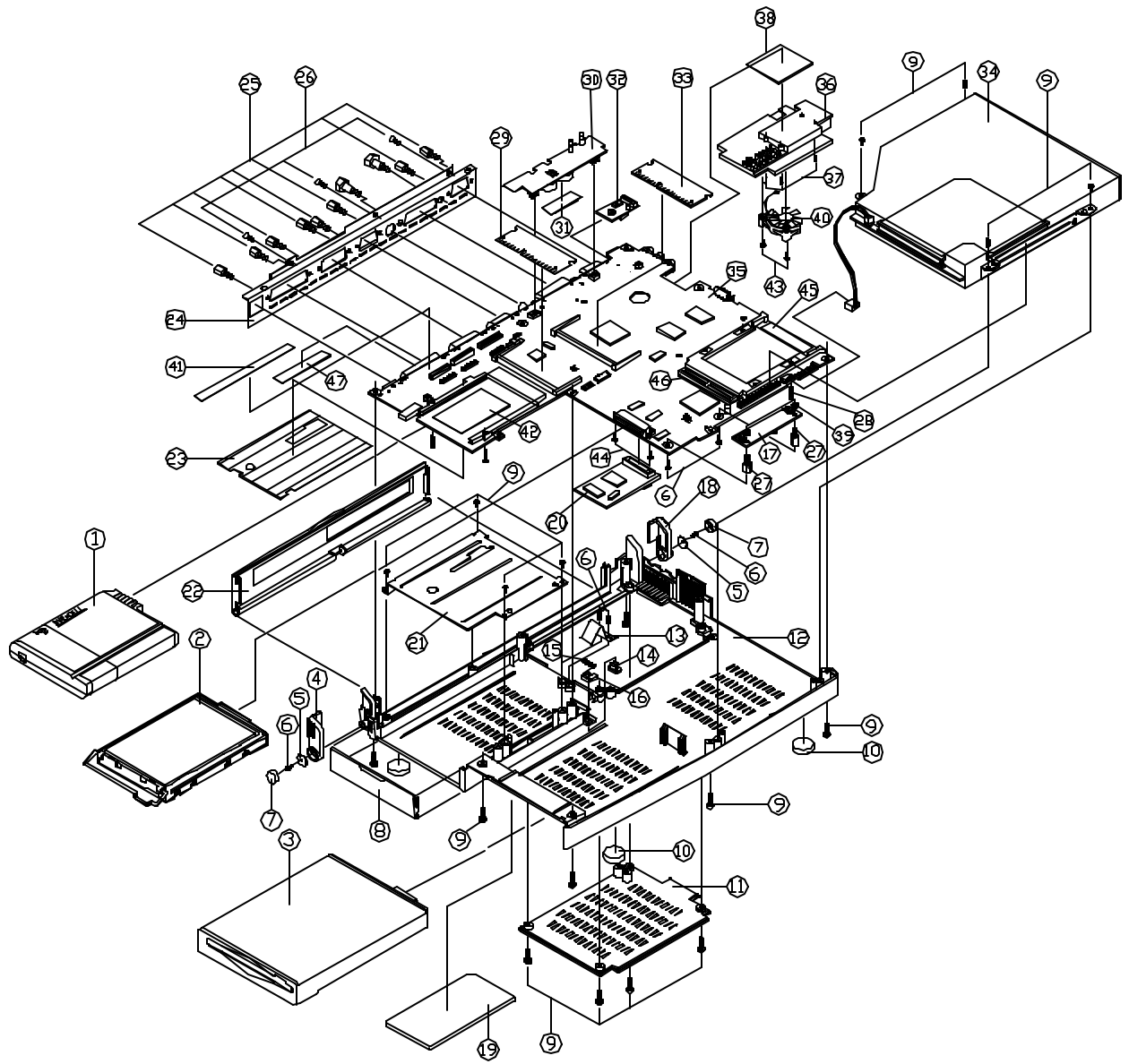

ITEM	PART NAME	PART NO	REMARK
1	DDN BATTERY	87-62080-000	
2	HDD ASS'Y 6200	参考爆炸圖 (99-62005-070)	
3	FDD ASS'Y 6200	参考爆炸圖 (99-62005-050)	
4	FOOT(L)	42-62061-020	
5	WASHER	37-02111-R50	
6	SCREW	35-41125-4RA	
7	FOOT RUBBER	47-62013-010	
8	BATTERY COVER	42-6203M-030	
9	SCREW	35-06125-6R0	
10	BOTTOM CASE RUBBER PAD	47-11023-010	
11	CPU COVER	42-62073-010	
12	BOTTOM CASE	39-62013-01A	
13	SPRING PLATE FOR BATTERY	38-62030-010	
14	LOCK KNOB	42-6208M-010	
15	LOCK KNOB SPRING	38-62020-010	
16	FDD LOCK	42-6208J-010	
17	SWITCH BOARD	77-6200S-D02	
18	FOOT(R)	42-62061-010	
19	FCC LABEL	45-62003-010	
20	MPEG CARD	77-60A00-D02	6008 機種使用
21	BATTERY BRACKET	33-6200M-010	
22	REAR COVER ASS'Y 6200	42-6207Q-001	
23	BATTERY BRACKET MYLAR	40-6205M-010	
24	REAR BRACKET	33-6200Q-010	
25	HEX STUD	34-07009-011	
26	SCREW	35-26130-6R0	
27	HEX STUD	34-6200S-010	
28	SCREW	35-01120-120	
29	RAM CARD 8M	77-6202T-270	
30	DC/DC MODULE	77-6200C-D02	
31	SPONGE FOR 168P	47-6209S-010	
32	POWER CPU 3.3V CARD	77-620A5-A01	
32	POWER CPU 2.9V CARD	77-620A5-A10	
33	RAM CARD 16M	77-6202T-470	
34	CD-ROM	参考爆炸圖 (99-62005-080)	
35	MAIN BOARD	77-62000-D01	
36	HEAT SINK	31-6200N-020	
37	SCREW	35-01120-080	
38	HEAT SINK RUBBER	47-6202N-010	
39	NUT NI M2.5	36-01111-250	
40	FAN	23-A5010-046	
41	MYLAR FOR M/B CON.	47-5209S-012	
42	MYLAR PCMCIA	40-6205P-010	
43	SCREW	35-41125-100	
44	SCREW	35-81120-6R0	
45	MYLAR FOR PCMCIA	40-6605P-010	
46	CARD BUS MYLAR	40-6205P-020	
47	DOCKING PIN MYLAR	40-6205R-010	

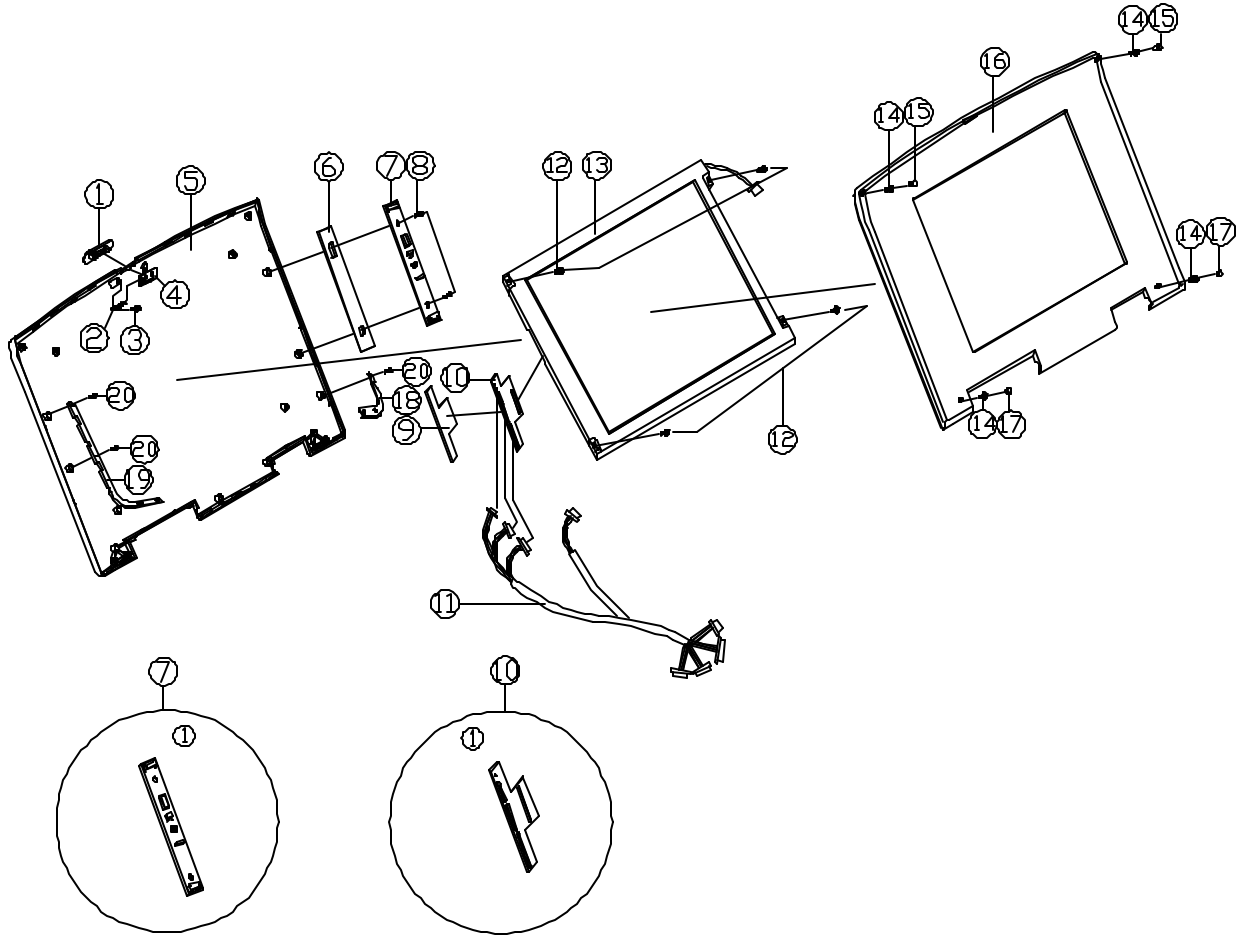

ITEM	PART NAME	PART NO	REMARK
1	HOOK KNOB	42-62081-010	
2	SPRING FOR HOOK	38-10R35-010	
3	SCREW	35-01720-5R0	
4	DISPLAY HOOK	42-620A1-010	
5	DISPLAY BACK PANEL(10.4")	39-62201-12A	NEC
5	DISPLAY BACK PANEL(10.4")	39-62201-22A	SAMSUNG
6	MYLAR FOR INVERTER	40-6205S-010	
7	INVERTER CARD	77-6200R-D01	TFT
7	①INVERTER CARD	77-6200R-D10	DUALSCAN
8	SCREW	35-41120-3R0	
9	MYLAR FOR DATA BOARD	40-6225S-010	
10	DATA BOARD	77-6220Z-D12	NEC
10	①DATA BOARD	77-6220Z-D20	SAMSUNG
11	CABLE (10.4")	28-77J40-41A	
12	SCREW	35-41130-6R0	
13	LCD	50-D5780-63N	NEC
13	LCD	50-D5777-63S	SAMSUNG
14	SCREW	35-01120-4R0	
15	DISPLAY RUBBER PAD (UP)	47-52021-010	
16	DISPLAY FRONT PANEL(10.4")	39-62201-21A	NEC/SAMSUNG
17	DISPLAY RUBBER PAD (BOTTOM)	47-52023-010	
18	HINGE BRACKET(R)	33-6200Y-020	
19	HINGE BRACKET(L)	33-6200Y-010	
20	SCREW	35-41125-4R0	

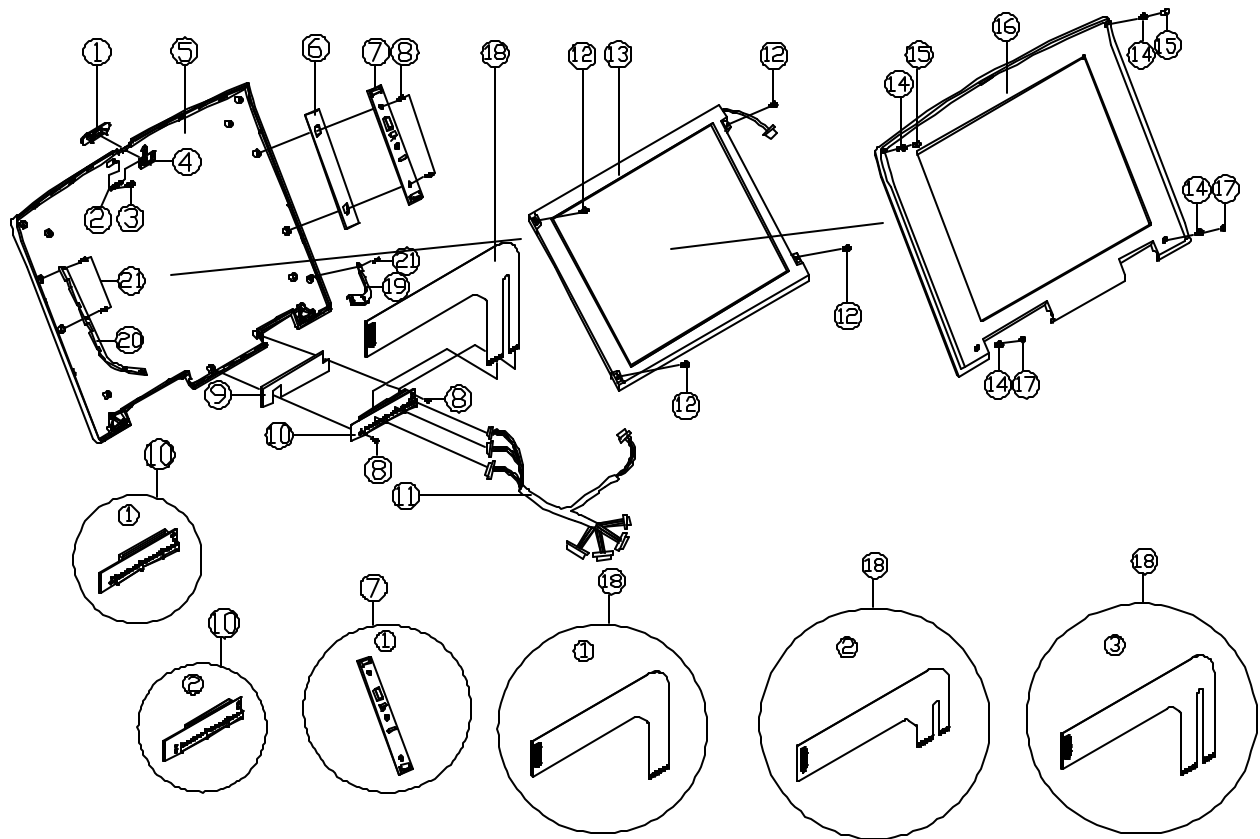

ITEM	PART NAME	PART NO	REMARK
1	HOOK KNOB	42-62081-010	
2	SPRING FOR HOOK	38-10R35-010	
3	SCREW	35-01720-5R0	
4	DISPLAY HOOK	42-620A1-010	
5	DISPLAY BACK PANEL(12.1")	39-62201-62A	NEC
5	DISPLAY BACK PANEL(12.1")	39-62201-42A	SAMSUNG
5	DISPLAY BACK PANEL(12.1")	39-62201-52A	HITACHI
5	DISPLAY BACK PANEL(12.1")	39-62201-32A	HOSIDEN
6	MYLAR FOR INVERTER	40-6205S-010	
7	INVERTER CARD	76-6200R-D01	TFT
7	①INVERTER CARD	76-6200R-D10	DUELSCAN
8	SCREW	35-41120-3R0	
9	MYLAR FOR DATA BOARD	40-6205S-020	
10	DATA BOARD	77-6220Z-D02	TFT
10	①DATA BOARD	77-6200Z-D01	DUELSCAN
10	②DATA BOARD	77-6220Z-D30	HOSIDEN
11	CABLE (12.1")	28-77J40-411	
12	SCREW	35-41130-6R0	
13	LCD	50-F5780-63N	NEC
13	LCD	50-F5708-63S	SAMSUNG
13	LCD	50-F5780-634	HITACHI
13	LCD	50-F5808-636	SANYO
13	LCD	50-F5778-63H	HOSIDEN
14	SCREW	35-01120-4R0	
15	DISPLAY RUBBER PAD (UP)	47-52021-010	
16	DISPLAY FRONT PANEL(12.1")	39-62201-31A	HOSIDEN
16	DISPLAY FRONT PANEL(12.1")	39-62001-11A	NEC,SA,SAM,HI
17	DISPLAY RUBBER PAD (BOTTOM)	47-52023-010	
18	FPC CABLE(12.1")	28-59R41-U10	NEC/SA-DATA
18	①FPC CABLE(12.1")	28-59R31-R20	SANYO/HITACHI
18	②FPC CABLE(12.1")	28-59R41-M20	HOSIDEN
18	③FPC CABLE(12.1")	28-59R41-291	HITACHI
19	HINGE BRACKET(R)	33-6200Y-020	
20	HINGE BRACKET(L)	33-6200Y-010	
21	SCREW	35-41125-4R0	

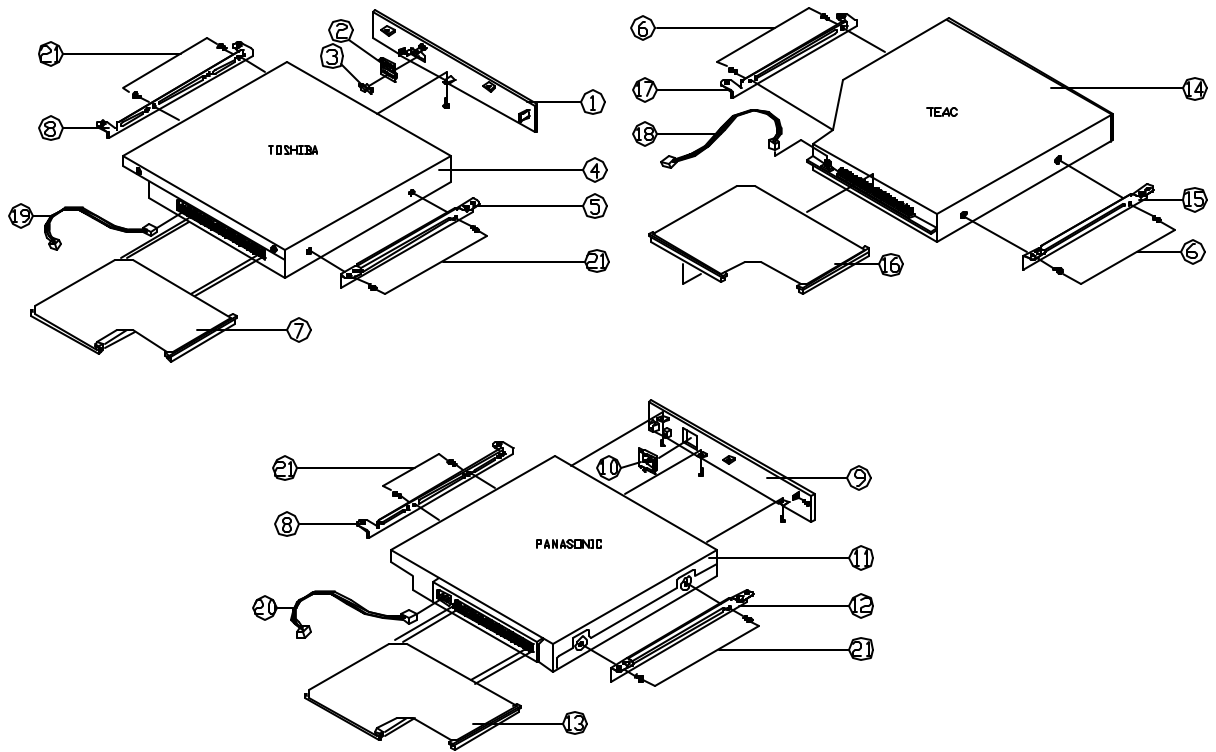

ITEM	PART NAME	PART NO	REMARK
1	CD-ROM PANEL	42-6207Z-110	TOSHIBA
2	CD-ROM EJECT BUTTON	42-6207Z-120	TOSHIBA
3	LED LENS	42-6207Z-130	TOSHIBA
4	CD-ROM	87-62010-080	TOSHIBA
5	CD-ROM BRACKET (L)	33-6200Z-120	TOSHIBA
6	SCREW	35-01125-2R5	TEAC
7	FPC CABLE	28-79R41-F80	TOSHIBA
8	CD-ROM BRACKET (R)	33-6200Z-110	TOSHIBA/PANASONIC
9	CD-ROM PANEL	42-6207Z-010	PANASONIC
10	CD-ROM EJECT BUTTON	42-6207Z-020	PANASONIC
11	CD-ROM	87-62010-090	PANASONIC
12	CD-ROM BRACKET (L)	33-6200Z-220	PANASONIC
13	FPC CABLE	28-79R44-E80	PANASONIC
14	CD-ROM	87-52010-052	TEAC
15	CD-ROM BRACKET (L)	33-6200Z-020	TEAC
16	FPC CABLE	28-79R41-E40	TEAC
17	CD-ROM BRACKET (R)	33-6200Z-010	TEAC
18	CABLE	28-77J06-191	TEAC
19	CABLE	28-77J06-19A	TOSHIBA
20	CABLE	28-77J04-191	PANASONIC
21	SCREW	35-01120-2R5	TOSHIBA/PANASONIC



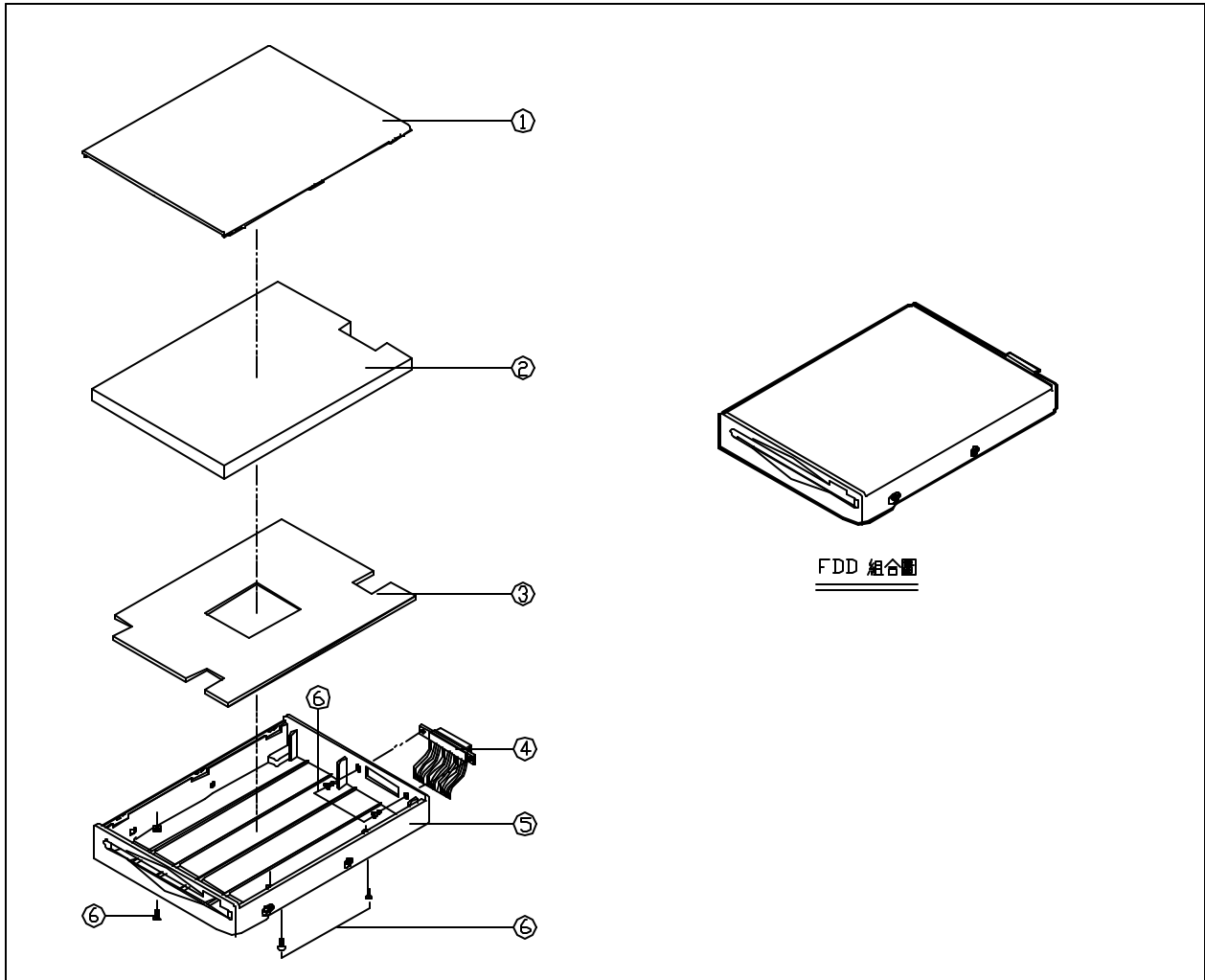

ITEM	PART NAME	PART NO	REMARK
1	FDD TOP CASE	42-6207J-010	
2	3.5" FDD	85-23211-557	TEAC
2	3.5" FDD	85-2321A-56P	PANASONIC
3	MYLAR	40-9205B-011	
4	FPC CABLE	28-59R20-580	
5	FDD BOTTOM CASE	42-6207J-020	
6	SCREW	35-B4125-3RA	

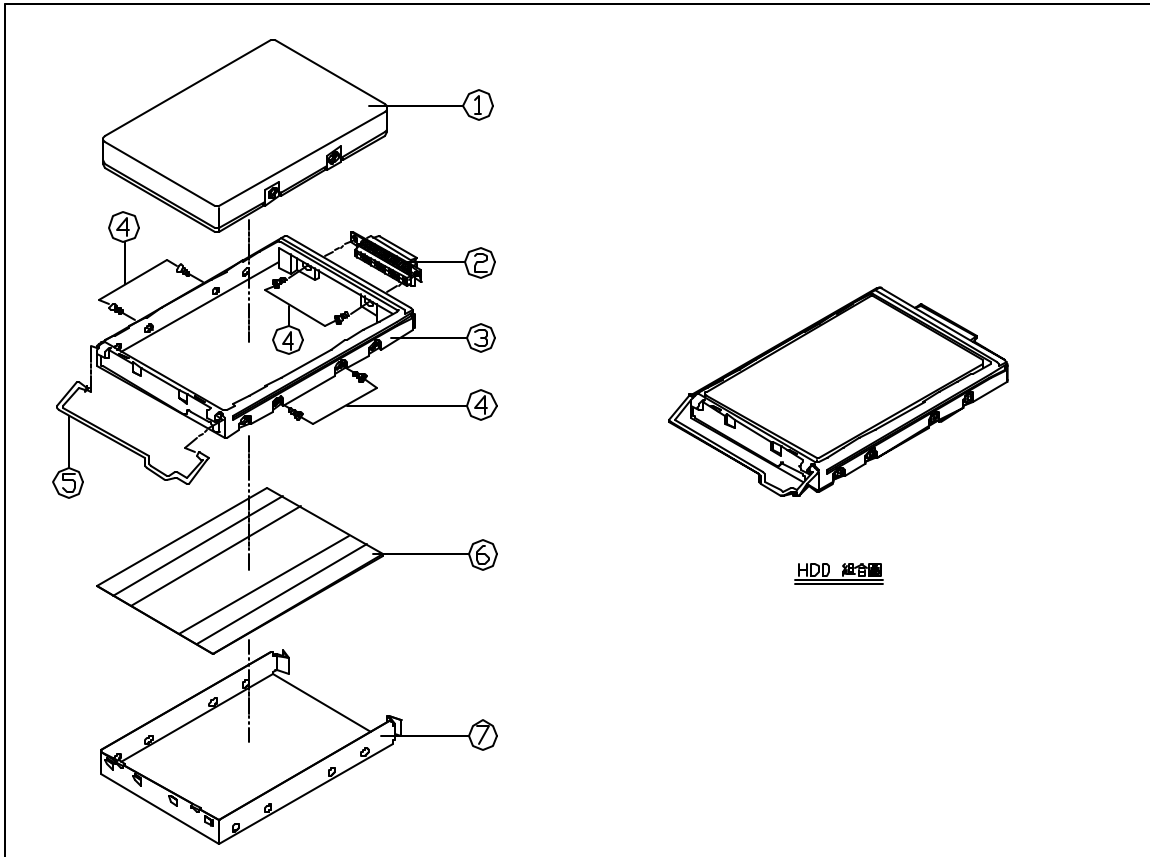

ITEM	PART NAME	PART NO	REMARK
1	2.5" HDD	85-12211-514	IBM
1	2.5" HDD	85-12211-542	SEAGATE
1	2.5" HDD	85-12211-59T	TOSHIBA
2	FPC CABLE	28-79R41-200	
3	HDD CASE	42-6207I-020	
4	SCREW	35-B6130-4R0	
5	HDD PULL BAR	33-6200I-020	
6	HDD MYLAR	40-6205I-010	
7	HDD PLATE	33-6200I-010	

