

# *Model 5100C*

## *Service Manual*

**The circuit schematics herein provided for reference only are not necessarily the latest version.**

**Mainboard**

**71-51C00-D02**

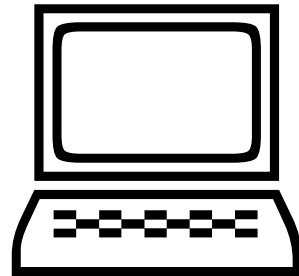

Specifications are subject to change without notice.

**Apr. 1999**



# TABLE OF CONTENT

☒	<b>SPECIFICATIONS</b> .....	<b>3</b>
☒	<b>I/O ADDRESS MAP</b> .....	<b>6</b>
☒	<b>SYSTEM MEMORY MAP</b> .....	<b>6</b>
☒	<b>MOTHERBOARD</b> .....	<b>7</b>
☒	<b>MICROPROCESSOR</b> .....	<b>7</b>
☒	<b>CHIPS</b> .....	<b>8</b>
	SOUTHBRIDGE CHIP-INTEL 82371EB (PIIX4E) .....	8
	VGA CONTROLLER-S3 280 .....	9
	PC CARD 95 (CARD BUS) INTERFACE CONTROLLER-TI-1225 .....	10
	SUPER I/O FLOPPY DISK CONTROLLER-FDC37N669 .....	11
	HIGH PERFORMANCE PCI AUDIO CHIP - ES1946 .....	12
	KEYBOARD CONTROLLER-M38867M8 .....	12
☒	<b>DEVICE PORT CONNECTOR DESCRIPTION</b> .....	<b>13</b>
	FLOPPY DISK DRIVE & SECONDARY IDE I NTERFACE .....	13
	HARD DISK DRIVE INTERFACE .....	14
	SECONDARY MASTER CD-ROM DRIVE INTERFACE .....	15
	RS-232C SERIAL INTERFACE .....	16
	PARALLEL INTERFACE .....	16
	EXPANSION MEMORY SOCKET .....	17
	INTERNAL TRACKPAD INTERFACE .....	19
	EXTERNAL MONITOR INTERFACE .....	19
	EXTERNAL S-VIDEO TV-OUT INTERFACE .....	19
	EXTERNAL KEYBOARD/PS2 M OUSE INTERFAC .....	20
	EXTERNAL USB (UNIVERSAL SERIAL BUS) INTERFACE .....	20
	PCMCIA CARDBUS INTERFACE.....	21
	LCD INTERFACE ( FOR XGA TFT).....	23
	PCI BUS INTERFACE ( FOR MODEM OPTION).....	24
☒	<b>DC/DC CONVERTER BOARD</b> .....	<b>25</b>
	INPUT CHARACTERISTICS .....	25
	EFFICIENCY 25	
	OUTPUT CHARACTERISTICS.....	25

SYSTEM ALARM.....	25
<input checked="" type="checkbox"/> <b>INVERTER BOARD</b> .....	<b>26</b>
PIN ASSIGNMENT.....	26
<input checked="" type="checkbox"/> <b>SYSTEM RESOURCE ALLOCATION</b> .....	<b>27</b>
(IN WINDOWS 98) .....	27
IRQ:     27	
DMA:     27	
<input checked="" type="checkbox"/> <b>PARTS LIST</b> .....	<b>28</b>
<input checked="" type="checkbox"/> <b>OPTIONAL PARTS</b> .....	<b>41</b>
POWER CORD .....	41
KEYBOARD.....	42

## ③ SPECIFICATIONS

### Processor

Intel® Celeron™ processors 300A/333/366/400/433 MHz

Intel® Mobile Pentium® II / Celeron™ processors 266/300/333/366 MHz

### Memory

Two 144pins SODIMM sockets

Supports EDO/Sync DRAM SODIMM (3.3V)

8/16/32/64/128 MB module (optional)

Expendable memory up to 256MB.

### System BIOS

256KB Flash ROM

Systemsoft, Plug and Play 1.0a, ACPI (1.0)

### Display

SVGA flat panel 12.1" TFT

AGP 1X

64-bit hardware 2D/3D Accelerator Graphics Engine

TV-out with Marco Vision® V7.1 anti-copy technology

4MB display memory SGRAM type

CRT resolution up to 1280x1024x16M

DuoView™ display capability under Windows 98

Support Zoomed Video Port

Support Software MPEG II playback (option).

### Storage

3.5" 3-mode FDD/12.7mm(h) LS-120

DVD-ROM (12.7mm)/CD-ROM (24X speed, 12.7mmH or 9.5mmH)

2.5" 12.7mm(h) HDD, support LBA mode

Support Master mode IDE, PIO mode 4/ATA-33 (Ultra DMA)

**Audio**

3D stereo sound system  
Compatible Sound-Blaster PRO™ version 3.01  
IIS interface for external ZV port or MPEG audio  
Built-in microphone  
Built-in 2 speakers  
Software Wavetable  
FM music synthesizer 16 bits stereo sound system

**PC Card Sockets**

Two type II (PCI) PCMCIA 3.3V/5V sockets  
Support Zoom Video Port (Socket A)/CardBus (PC Card95)

**Interface**

Built-in trackpad (PS/2)  
One USB port  
One serial port  
One parallel port (LPT1), support ECP/EPP 1.7a and 1.9  
Infrared file transfer, IrDA 1.0/ASKIR  
External CRT monitor  
One S-Video jack for TV output  
One External keyboard/mouse (PS/2 type) port  
One headphone jack  
One microphone jack  
One RJ-11 jack for Plug & Play Modem Accessory (option)  
DC-in jack

**Communication**

Wireless Infrared transfer, IrDA 1.0 compliant  
56K Plug & Play Modem v.90 compliant (option)

**Power Management**

- Support APM v1.2
- Support ACPI v1.0
- Soft Off by system Power button
- Support suspend to disk
- Battery low suspend
- Resume from alarm time
- Resume from modem ring (COM port only)

**Power**

- Full range AC adapter – AC in 100-240V, 47-63Hz
- Support one removable Ni-MH/Li-Ion Battery

**Size & Weight**

- 280mm(w)x240mm(d)x39.5mm(h)
- 2.8kg (with Lithium-Ion battery)

**Keyboard**

- 84 keys Win95 keyboard include numeric keypad.

**Environment**

- Temperature:
  - Operating: 5 C~35 C, Non-Operating: 20 C~60 C
- Humidity
  - Operating: 20%~80%, Non-Operating: 10%~90%

**Optional**

- 5001 Ni-MH Battery
- 5002 Li-Ion Battery
- 5002S Smart Li-Ion Battery
- 5003 DVD-ROM Drive Kit
- 5005 LS-120 MB Floppy Drive Kit
- 1008 MPEG playback kit
- 2005 Car Adapter
- 5008 56K v.90 Modem

### ③ I/O Address Map

Hex range	Device
000 - 00F	DMA controller-1
020 - 021	Interrupt controller-1
040 - 043	Timer 1
048 - 04B	Timer 2
060 - 06E	KB controller M38813 chip select
070 - 071	RTC and NMI mask
080 - 08F	DMA page register
0A0 - 0A1	Interrupt controller-2
0C0 - 0DF	DMA controller-2
1F0 - 1F7	Fixed disk select
3F6 , 3F7	
2F8 - 2FF	Serial port 2
378 - 37A	Parallel port 1
3B4 , 3B5	CRT controller index (mono)
3D4 , 3D5	CRT controller index (color)
3BA	Feature control
3C0 - 3DA	
3F2 - 3F7	Floppy disk controller
3F0 , 3F1	configuration port
3F8 - 3FF	Serial port 1

### ③ System Memory Map

ADDRESS	SIZE	FUNCTION
000000 - 09FFFF	640KB	640KB Base Memory
0A0000 - 0BFFFF	128KB	Video RAM
0C0000 - 0CBFFF	48KB	VGA BIOS
0CC000 - 0DFFFF	80KB	Reserved
0E0000 - 0EFFFF	64KB	System BIOS for SCU,PCI,PnP, PMU
0F0000 - 0FFFFFF	64KB	System BIOS for Kernal
100000 -	16MB to 256MB	Extended Memory

## ③ Motherboard

The motherboard is designed with *Intel Celeron* processor based and includes the following CHIPSET function:

- 82371EB PIIX4E chipset solution from INTEL
- 82443ZX Northbridge chipset solution from INTEL
- **S3 280 AGP IX** Multimedia Flat Panel Controller
- **TI 1225** PC CARD Controller
- EDC37N669 super I/O Floppy Disk Controller
- ES1946 PCI Audio Chip
- M38867 Keyboard Controller

## ③ Microprocessor

The model 5100C is equipped with Intel Celeron processor base.

### A: Intel Celeron processor 300A/333/366 product line

Features:

- ) P6 core (PPGA package)
- ) Separate 16K instruction and 16K data level one caches
- ) Integrated 128K second level cache
- ) Cachenable 4GB of system memory
- ) High performances Floating Point Unit
- ) Enhanced 64 bits data bus
- ) Dynamic Execution micro-architecture
- ) MMX media technology instruction
- ) Power management feature
- ) Low power GTL+ Host bus specification

### B. 443ZX Host Bridge System Controller

Intel's 443ZX Host Bridge system controller is a highly integrated device that combines the processor bus controller, the DRAM controller, and the PCI bus controller into one component. The 443ZX Host Bridge has multiple power management features as below:

- ) Host Interface
- ) Memory Interface
- ) PCI Interface
- ) AGP Interface

## ③ Chips

### **Southbridge Chip-INTEL 82371EB (PIIX4E)**

It contains the following features:

- ) Support Kits for both Pentium and Pentium II Microprocessors
  
- ) Multifunction PCI to ISA Bridge
  - Support PCI at 33 MHz
  - Support PCI Rev 2.1 Specification
  - Support Full ISA or Extended I/O BUS
  -
  
- ) Support Mobile Deep Green Environments
  - 3.3V Operation with 5V Tolerant Buffers
  - Ultra-low Power for Mobile Environments Support
  
- ) Full support for ACPI (Advanced Configuration and Power Interface) Revision 1.0
  
- ) Integrated IDE Controller
  - Support Ultra DMA/33
  
- ) Support two 82C37 Enhanced DMA Controller
  
- ) Support two 82C59 Interrupt Controller
  
- ) Support 82C54 Timer Based
  
- ) Support UHCI USB Ports
  
- ) Support SMBus

## VGA Controller-S3 280

The *S3 86260* Multimedia Flat Panel Controller is a DRAM based, fully integrated LCD, CRT & TV 64 bits controller for AGP systems. It contains the following functions:

- ) Support displays for 4MB
- ) 64bit high performance 2D/3D Graphic Engine
- ) Support bus master AGP and SGRAM memory
- ) Support 18 bit TFT panels up to 1024x768 resolution
- ) Support non-interlaced 1280x1024x64k, 1024x768x16M&16:9(TV OUT), 800x600x16M, and 640x480x16M color on CRT.
- ) Simultaneous display in 18 bit color on flat panel and CRT
- ) Internal buffer provides flicker reduction
- ) *S3 86260* DAC can directly interface with a standard off-the-shelf NTSC/PAL encoder.  
Composite synchronization signals support standard home TV connection up to 1280x1024x16M and 16:9 wide mode.
- ) Graphic functions optimized by a 64-bit internal data bus and VGA, SVGA , and XGA flat panel
- ) Provide flexible and extensive power management capabilities and support four states of VESA Display Power Management Signaling standard
- ) Industry leading DuoView Simultaneous display at Windows 98
- ) Fully compliant ZV-port interface with device driver support for VPM
- ) Motion compensation

## **PC Card 95 (Card Bus) Interface Controller-TI-1225**

TI Card bus Interface Controller 1225 implements the PCMCIA 2.0/JEIDA 4.1 standard. It contains the following functions:

- ) Support 2 PCMCIA 2.1 & JEIDA 4.2 R2 cards or 2 CardBus cards
- ) Yenta Registers-compatible
- ) Support Zoom Video Mode
- ) PCMCIA dual-socket interface
- ) One-Slot plus MPEG three Zoomed Video Ports support
- ) Bus Master Transfer capability
- ) Support both 5V and 3.3V PC cards
- ) Support PCMCIA\_ATA Specification
- ) Support Advanced Submicron Low Power CMOS Technology
- ) Support ACPI 1.0 compliant
- ) 208 pin TQFP package

### **ZV Port Custom Interface**

The ZV (Zoomed Video) Port is a single source, point-to-point, uni-directional video bus between a PC Card socket and a VGA controller. The ZV Port complies with CCIR601 timing to allow NTSC decoders to deliver real-time digital video straight into the VGA frame buffer from a PC Card. The ZV Port also allows an industry standard mechanism for transferring digital audio PCM data to a low cost DAC for conversion to an analog signal.

## **Super I/O Floppy Disk Controller-FDC37N669**

The SMC FDC37N669 super I/O is optimized for motherboard applications. It provides the following:

- ) Intelligent Auto Power Management
- ) 16 Bit Address Qualification
- ) 1.44MB Super I/O Floppy Disk Controller
  - Support Vertical Recording Format
  - 16 Byte Data FIFO
  - Enhanced Digital Data Separator. Data rate up to 1Mb/s.
- ) Multi-Mode Parallel Port with ChiProtect Circuitry
  - Standard Mode
    - IBM PC/AT and PS/2 compatible bi-directional Parallel port.
  - Enhanced Mode
    - Enhanced Parallel Port (EPP) Compatible
  - High Speed Mode
    - Microsoft and Hewlett Packard Extended Capabilities Port (ECP)  
Compatible
- ) Serial Port
  - Two high speed NS16C550 compatible UARTs with Send/Receive 16 Byte FIFOs
  - Programmable Baud Rate Generator
  - Modem Control Circuitry
  - Infrared-IrDA, HPSIR, ASKIR, Consumer IR Support

## **High Performance PCI Audio Chip- ES1946**

- ) 500-MIPS-equivalent dual-engine PCI audio accelerator
- ) HRTF 3-D positional audio acceleration
- ) 64-Channel wavetable synthesis
- ) Advanced platform for interactive 3-D gaming, DVD movie playback, and internet communications
- ) Full plug and play
- ) Multi-Stream DirectSound and DirectSound3D acceleration
- ) Full DOS Game compatibility
- ) I2S Zoomed Video interface

## **Keyboard Controller-M38867M8**

- ) Memory size : 1024 bytes (RAM)
- ) Timers : 8 bit prescaler X 4 + 8 bit timer X 3
- ) Comparator : 4 bit X 8 channels
- ) Bus interface : 2 bytes
- ) Key on wake-up : 8 channels
- ) Interrupts : 8 external, 7 internal, and 1 software
- ) A-D converter: 8 channels
- ) D-A converter: 2 channels
- ) PWM: 2 channels
- ) System bus interface: 8042 type

## ③ Device Port Connector Description

### Floppy Disk Drive & Secondary IDE Interface

Use one 60-pin B/B connector. The pin's configurations are as below:

Pin	Description	Pin	Description
1	VCCS	2	VCCS
3	MTR0#	4	DRV0#
5	3MODE#	6	INDEX#
7	TRK0#	8	DSKCHG#
9	HSEL#	10	DIR#
11	RDATA#	12	STEP#
13	WP_FD#	14	WDAT#
15	WGATE#	16	NC
17	CDRST#	18	GND
19	DDS7	20	DDS8
21	DDS6	22	DDS9
23	DDS5	24	DDS10
25	DDS4	26	DDS11
27	DDS3	28	DDS12
29	DDS2	30	DDS13
31	DDS1	32	DDS14
33	DDS0	34	DDS15
35	GND	36	NC
37	SDREQ	38	GND
39	SDIOW#	40	GND
41	SDIOR#	42	GND
43	SIORDY	44	CSEL
45	SDACK#	46	GND
47	CD_IRQ	48	NC
49	SDA1	50	PDIAG
51	SDA0	52	SDA2
53	CS1S#	54	CS3S#
55	SHD_LED#	56	GND
57	VCCS	58	VCCS
59	GND	60	NC

## Hard Disk Drive Interface

Use a 50-pin B/B connector. The 50-pin connector has the following pin configurations:

Pin	Description	Pin	Description
1	GND	2	GND
3	GND	4	GND
5	HDRST#	6	GND
7	DDP7	8	DDP8
9	DDP6	10	DDP9
11	DDP5	12	DDP10
13	DDP4	14	DDP11
15	DDP3	16	DDP12
17	DDP2	18	DDP13
19	DDP1	20	DDP14
21	DDP0	22	DDP15
23	GND	24	NC
25	PDREQ	26	GND
27	PDIOW#	28	GND
29	PDIOR#	30	GND
31	PIORDY	32	CSEL
33	PDACK#	34	GND
35	IRQ14	36	NC
37	PDA1	38	NC
39	PDA0	40	PDA2
41	CS1P#	42	CS3P#
43	PHD LED#	44	GND
45	HDD_VCC	46	HDD_VCC
47	GND	48	NC
49	NC	50	NC

## Secondary Master CD-ROM Drive Interface

Use a 50-pin B/B connector. The 50-pin connector has the following pin configurations:

Pin	Description	Pin	Description
1	CD_L	2	CD_R
3	AGND	4	AGND
5	CDRST#	6	SDDP8
7	SDDP7	8	SDDP9
9	SDDP6	10	SDDP10
11	SDDP5	12	SDDP11
13	SDDP4	14	SDDP12
15	SDDP3	16	SDDP13
17	SDDP2	18	SDDP14
19	SDDP1	20	SDDP15
21	SDDP0	22	SSDREQ
23	GND	24	SSDIOR#
25	SSDIOW#	26	GND
27	SIORDY	28	SDACK#
29	CDIRQ	30	NC
31	SSDA1	32	PDIAG
33	SSDA0	34	SSDA2
35	SCS1S#	36	SCS3S#
37	SHD_LED#	38	CD_VCC
39	CD_VCC	40	CD_VCC
41	CD_VCC	42	CD_VCC
43	GND	44	GND
45	GND	46	GND
47	CSEL	48	GND
49	NC	50	NC

## RS-232C Serial Interface

The RS-232C Serial Interface uses a 9-pin D-sub male connector which has the following pin configurations:

Pin	Description
1	DCD (DATA Carrier Detect)
2	RXD (Received Data)
3	TXD (Transmitted Data)
4	DTR (Data Terminal Ready)
5	GND (Signal Ground)
6	DSR (Data Set Ready)
7	RTS (Request To Send)
8	CTS (Clear To Send)
9	RI (Ring Indicator)

## Parallel Interface

The parallel interface is implemented through using a 25-pin D-sub female connector which has the following pin configurations:

Pin	Description	Pin	Description
1	Strobe#	2	Data 0
3	Data 1	4	Data 2
5	Data 3	6	Data 4
7	Data 5	8	Data 6
9	Data 7	10	ACK#
11	Busy	12	Paper Empty
13	Select	14	Auto Linefeed#
15	Error#	16	Initialize#
17	Select In	18	Ground
19	Ground	20	Ground
21	Ground	22	Ground
23	Ground	24	Ground
25	Ground		

## Expansion Memory Socket

The model 5100C has two 144-pin SODIMM type expansion memory sockets with the following pin configurations:

### ④ SOCKET 1:

Pin	Description	Pin	Description	Pin	Description	Pin	Description
1	GND	2	GND	3	MD0	4	MD32
5	MD1	6	MD33	7	MD2	8	MD34
9	MD3	10	MD35	11	MEM-VCC	12	MEM-VCC
13	MD4	14	MD36	15	MD5	16	MD37
17	MD6	18	MD38	19	MD7	20	MD39
21	GND	22	GND	23	DQMA0	24	DQMA4
25	DQMA1	26	DQMA5	27	MEM-VCC	28	MEM-VCC
29	IMA0	30	IMA3	31	IMA1	32	IMA4
33	IMA2	34	IMA5	35	GND	36	GND
37	MD8	38	MD40	39	MD9	40	MD41
41	MD10	42	MD42	43	MD11	44	MD43
45	MEM-VCC	46	MEM-VCC	47	MD12	48	MD44
49	MD13	50	MD45	51	MD14	52	MD46
53	MD15	54	MD47	55	GND	56	GND
57	MECC0	58	MECC4	59	MECC1	60	MECC5
61	MEMCLK1	62	CKE0	63	MEM-VCC	64	MEM-VCC
65	SRAS#	66	SCAS#	67	WEA#	68	CKE1
69	IRAS#0	70	IMA12	71	IRAS#1	72	IMA13
73	GND	74	MEMCLK2	75	GND	76	GND
77	MECC2	78	MECC6	79	MECC3	80	MECC7
81	MEM-VCC	82	MEM-VCC	83	MD16	84	MD48
85	MD17	86	MD49	87	MD18	88	MD50
89	MD19	90	MD51	91	GND	92	GND
93	MD20	94	MD52	95	MD21	96	MD53
97	MD22	98	MD54	99	MD23	100	MD55
101	MEM-VCC	102	MEM-VCC	103	IMA6	104	IMA7
105	IMA8	106	IMA11	107	GND	108	GND
109	IMA9	110	IMA12	111	IMA10	112	N.C
113	MEM-VCC	114	MEM-VCC	115	DQMA2	116	DQMA6
117	DQMA3	118	DQMA7	119	GND	120	GND
121	MD24	122	MD56	123	MD25	124	MD57
125	MD26	126	MD58	127	MD27	128	MD59
129	MEM-VCC	130	MEM-VCC	131	MD28	132	MD60
133	MD29	134	MD61	135	MD30	136	MD62
137	MD31	138	MD63	139	GND	140	GND
141	SDA_RA	142	SCL_RA	143	MEM-VCC	144	MEM-VCC

④ SOCKET 2:

Pin	Description	Pin	Description	Pin	Description	Pin	Description
1	GND	2	GND	3	MD0	4	MD32
5	MD1	6	MD33	7	MD2	8	MD34
9	MD3	10	MD35	11	MEM-VCC	12	MEM-VCC
13	MD4	14	MD36	15	MD5	16	MD37
17	MD6	18	MD38	19	MD7	20	MD39
21	GND	22	GND	23	DQMA0	24	DQMA4
25	DQMA1	26	DQMA5	27	MEM-VCC	28	MEM-VCC
29	IMA0	30	IMA3	31	IMA1	32	IMA4
33	IMA2	34	IMA5	35	GND	36	GND
37	MD8	38	MD40	39	MD9	40	MD41
41	MD10	42	MD42	43	MD11	44	MD43
45	MEM-VCC	46	MEM-VCC	47	MD12	48	MD44
49	MD13	50	MD45	51	MD14	52	MD46
53	MD15	54	MD47	55	GND	56	GND
57	MECC0	58	MECC4	59	MECC1	60	MECC5
61	MEMCLK3	62	CKE2	63	MEM-VCC	64	MEM-VCC
65	SRAS#	66	SCAS#	67	WEA#	68	CKE3
69	IRAS#2	70	IMA12	71	IRAS#3	72	IMA13
73	GND	74	MEMCLK4	75	GND	76	GND
77	MECC2	78	MECC6	79	MECC3	80	MECC7
81	MEM-VCC	82	MEM-VCC	83	MD16	84	MD48
85	MD17	86	MD49	87	MD18	88	MD50
89	MD19	90	MD51	91	GND	92	GND
93	MD20	94	MD52	95	MD21	96	MD53
97	MD22	98	MD54	99	MD23	100	MD55
101	MEM-VCC	102	MEM-VCC	103	IMA6	104	IMA7
105	IMA8	106	IMA11	107	GND	108	GND
109	IMA9	110	IMA12	111	IMA10	112	N.C
113	MEM-VCC	114	MEM-VCC	115	DQMA2	116	DQMA6
117	DQMA3	118	DQMA7	119	GND	120	GND
121	MD24	122	MD56	123	MD25	124	MD57
125	MD26	126	MD58	127	MD27	128	MD59
129	MEM-VCC	130	MEM-VCC	131	MD28	132	MD60
133	MD29	134	MD61	135	MD30	136	MD62
137	MD31	138	MD63	139	GND	140	GND
141	SDA_RB	142	SCL_RB	143	MEM-VCC	144	MEM-VCC

## Internal trackpad Interface

The following is the pin configuration for the connector:

Pin	Description
1	VCC
2	IMDATA
3	IMCLK
4	SWR
5	SWL
6	NC
7	NC
8	GND

## External Monitor Interface

Use a 15-pin D-sub female connector that has the following configuration:

Pin	Description
1	BRED
2	BGREEN
3	BBLUE
4	N.C
5	GND
6	GND
7	GND
8	GND
9	N.C
10	GND
11	N.C
12	DDCDA
13	DHSYNC
14	DVSYNC
15	DDCLK

RGB Out -

Output Impedance : 75

RGB peak voltage: 0.7Vpp

## External S-video TV-out Interface

Pin	Description
1	GND
2	GND
3	LUMA
4	CRMA

## External Keyboard/PS2 Mouse Interfac

Pin	Description
1	EKDA
2	NC
3	GND
4	VCC
5	EKCLK
6	NC

## External USB (Universal Serial Bus) Interface

Pin	Description
1	USB_VCCA
2	USBP0-
3	USBP0+
4	GND

## PCMCIA CardBus Interface

### ④ Socket A:

Pin	Description	Pin	Description	Pin	Description
1	GND	35	GND	69	GND
2	A-CD3	36	A-CA5	70	A-CA19
3	A-CD4	37	A-CA4	71	A-CA20
4	GND	38	GND	72	GND
5	A-CD5	39	A-CA3	73	A-CA21
6	A-CD6	40	A-CA2	74	A-VCC-C
7	GND	41	GND	75	GND
8	A-CD7	42	A-CA1	76	GND
9	A-CE1#	43	A-CA0	77	A-VPP
10	GND	44	GND	78	A-CA22
11	A-CA10	45	A-CD0	79	GND
12	A-OE#	46	A-CD1	80	A-CA23
13	GND	47	GND	81	A-CA24
14	A-CA11	48	A-CD2	82	GND
15	A-CA9	49	A-WP#	83	A-CA25
16	GND	50	GND	84	A-VS2
17	A-CA8	51	GND	85	GND
18	A-CA13	52	A-CD1#	86	A-RESET
19	GND	53	A-CD11	87	A-WAIT#
20	A-CA14	54	GND	88	GND
21	A-WE#	55	A-CD12	89	A-INPACK
22	GND	56	A-CD13	90	A-REG#
23	A-RDYBY#	57	GND	91	GND
24	A-VCC-C	58	A-CD14	92	A-BVD2#
25	GND	59	A-CD15	93	A-BVD1#
26	GND	60	GND	94	GND
27	A-VPP	61	A-CE2#	95	A-CD8
28	A-CA16	62	A-VS1	96	A-CD9
29	GND	63	GND	97	GND
30	A-CA15	64	A-IORD#	98	A-CD10
31	A-CA12	65	A-IOWR#	99	A-CD2#
32	GND	66	GND	100	GND
33	A-CA7	67	A-CA17		
34	A-CA6	68	A-CA18		

④ **Socket B:**

Pin	Description	Pin	Description	Pin	Description
1	GND	35	GND	69	GND
2	B-CD3	36	B-CA5	70	B-CA19
3	B-CD4	37	B-CA4	71	B-CA20
4	GND	38	GND	72	GND
5	B-CD5	39	B-CA3	73	B-CA21
6	B-CD6	40	B-CA2	74	B-VCC-C
7	GND	41	GND	75	GND
8	B-CD7	42	B-CA1	76	GND
9	B-CE1#	43	B-CA0	77	B-VPP
10	GND	44	GND	78	B-CA22
11	B-CA10	45	B-CD0	79	GND
12	B-OE#	46	B-CD1	80	B-CA23
13	GND	47	GND	81	B-CA24
14	B-CA11	48	B-CD2	82	GND
15	B-CA9	49	B-WP#	83	B-CA25
16	GND	50	GND	84	B-VS2
17	B-CA8	51	GND	85	GND
18	B-CA13	52	B-CD1#	86	B-RESET
19	GND	53	B-CD11	87	B-WAIT#
20	B-CA14	54	GND	88	GND
21	B-WE#	55	B-CD12	89	B-INPACK
22	GND	56	B-CD13	90	B-REG#
23	B-RDYBY#	57	GND	91	GND
24	B-VCC-C	58	B-CD14	92	B-BVD2#
25	GND	59	B-CD15	93	B-BVD1#
26	GND	60	GND	94	GND
27	B-VPP	61	B-CE2#	95	B-CD8
28	B-CA16	62	B-VS1	96	B-CD9
29	GND	63	GND	97	GND
30	B-CA15	64	B-IORD#	88	B-CD10
31	B-CA12	65	B-IOWR#	99	B-CD2#
32	GND	66	GND	100	GND
33	B-CA7	67	B-CA17		
34	B-CA6	68	B-CA18		

## LCD Interface ( For XGA TFT)

Pin	Description	Pin	Description
1	LCDVDD	26	LCDVDD
2	GND	27	GND
3	PP0	28	PP2
4	PP1	29	PP3
5	GND	30	GND
6	PP4	31	PP6
7	PP5	32	PP7
8	GND	33	GND
9	PP12	34	PP10
10	PP13	35	PP11
11	GND	36	GND
12	PP16	37	PP14
13	PP17	38	PP15
14	GND	39	GND
15	VD48	40	VCC3
16	VD47	41	VCC3
17	GND	42	GND
18	INTMIC	43	MICGND
19	LID	44	BATON
20	ACIN	45	BAT_BEEP
21	BATCHA	46	BATFULL
22	ENABKKL	47	BRIGADJ
23	GND	48	GND
24	NC	49	NC
25	B+	50	B+

## PCI BUS Interface ( For Modem Option)

Pin (CON26)	Description	Pin (CON26)	Description	Pin (CON25)	Description
1	VCC3	35	AD11	1	AD23
2	VCC3	36	CBE#0	2	AD24
3	GND	37	AD10	3	AD22
4	GND	38	AD7	4	AD25
5	CBE#2	39	AD9	5	AD21
6	REQ#1	40	AD5	6	AD26
7	FRAME#	41	AD8	7	AD20
8	GNT#1	42	AD6	8	AD27
9	IRDY#	43	MONO_I	9	AD19
10	PCIMODEM	44	MONO_O	10	AD28
11	TRDY#	45	GND	11	AD18
12	PRST#	46	GND	12	AD29
13	DEVSEL#	47	GND	13	AD17
14	INT#	48	GND	14	AD30
15	STOP#	49	GND	15	AD16
16	TI_PME#	50	GND	16	AD31
17	PERR#			17	VCC
18	CRE#3			18	VCC
19	SERR#			19	VCC
20	IDSEL			20	VCC
21	VCC			21	VCC
22	VCC			22	VCC
23	PAR			23	GND
24	MODEMRI			24	GND
25	CBE#1			25	GND
26	AD4			26	GND
27	AD15			27	VCC3
28	AD3			28	VCC3
29	AD14			29	VCC3
30	AD2			30	VCC3
31	AD13				
32	AD1				
33	AD12				
34	AD0				

## ③ DC/DC Converter Board

### Input Characteristics

Input Voltage ---From AC Adapter:	9.0V~21V
---From Battery:	12V

### Efficiency

The total efficiency is 85% minimum at full load condition.

### Output Characteristics

+5V and +3.45V Power on simultaneously

Voltage	Regulation	Ripple & Noise	Current Typical	Current Peak
+5V	4%	150mVp-p	4.6A	6.4A
+3.45V	4%	150mVp-p	4.0A	6.0A
+12V	-5%~+5%	200mVp-p	0.2A	0.5A

### System Alarm

Type	Alarm Time	Shut Down
LI-ION (Dumb)	3-20 min	12.2V0.5V
NT-MH (Dumb)	3-20 min	7.6V0.5V

## ③ Inverter Board

### Pin Assignment

③ 12.1”(H) Connector 1; Input Connector

Pin No.	Symbol	Description
1	B+	Dc Voltage Supply the Operating Power
2	B+	Dc Voltage Supply the Operating Power
3	GND	GND
4	GND	GND
5	Brigadj	Given an analog step by step signal in the rang of 0 to 2.5vdc to Control the Lamp brightness
6	BKLO	Control the Inverter ON/OFF

③ 12.1”(V) Connector 1; Input Connector

Pin No.	Symbol	Description
1	B+	Dc Voltage Supply the Operating Power
2	B+	Dc Voltage Supply the Operating Power
3	GND	GND
4	GND	GND
5	Brigadj	Given an analog step by step signal in the rang of 0 to 2.5vdc to Control the Lamp brightness
6	BKLO	Control the Inverter ON/OFF

③ Connector 2; Ouput Connector

Pin No.	Description
1	High voltage side of the Lamp
2	Low voltage side of the Lamp

<b>Lamp Current:</b>	2.5 0.5 ~ 5.0 0.5
<b>Lamp Voltage:</b>	600 Vrms
<b>Starting Voltage:</b>	1400 @ 0
<b>Working Frequency:</b>	30~60 kHz
<b>Brightness Control:</b>	0~2.5 Vdc
<b>B+:</b>	7~22 V
<b>BKLO:</b>	0V (OFF) 3.3V(ON)

## ③ System Resource Allocation

(In Windows 98)

### **IRQ:**

IRQ 0: System timer  
IRQ 1: Standard 101/102-key or Microsoft Natural Keyboard  
IRQ 2: Programmable interrupt controller  
IRQ 3: Infrared PnP Serial Port (\*PNP0510)  
IRQ 4: CommunicationS Port (COM1)  
IRQ 5: ESS SOLO-1 PCI AudioDrive  
IRQ 5: IRQ Holder for PCI Steering  
IRQ 6: Standard Floppy Disk Controller  
IRQ 7: Printer Port (LPT1)  
IRQ 8: System CMOS/real time clock  
IRQ 9: Xircom CreditCard Ethernet Adapter 10/100  
IRQ 10: Texas Instruments PCI-1225 CardBus Controller  
IRQ 10: Intel 8237/AB/EB PCI to USB Universal Host Controller  
IRQ 10: IRQ Holder for PCI Steering  
IRQ 10: IRQ Holder for PCI Steering  
IRQ 11: Texas Instruments PCI-1225 CardBus Controller  
IRQ 11: IRQ Holder for PCI Steering  
IRQ 12: PS/2 Compatible Mouse Port  
IRQ 13: Numeric data processor  
IRQ 14: Intel 8237/AB/EB PCI Bus Master IDE Controller  
IRQ 14: Primary IDE controller (dual fifo)  
IRQ 15: Intel 82371/AB/EB PCI Bus Master IDE Controller  
IRQ 16: Secondary IDE controller (dual fifo)

### **DMA:**

DMA 1: ESS SOLO-1 DOS Emulation  
DMA 2: Standard Floppy Disk Controller  
DMA 4: Direct memory access Controller

### ③ Parts List

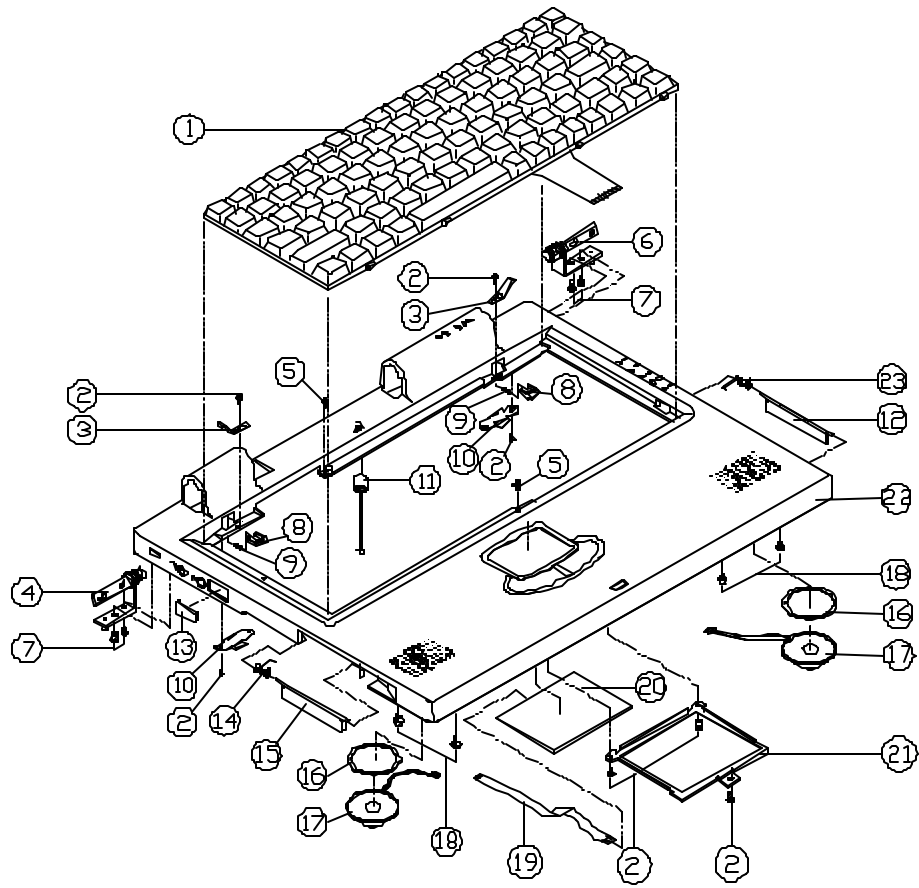

ITEM	PART NAME	PART NO	REMARK
1	KEYBOARD	80-31308-700	
2	SCREW	35-41120-3RA	
3	K/B SPRING PLATE	3B-35020-010	
4	HINGE (L) ASS'Y	79-5100Y-020	
5	SCREW	35-06125-6RA	
6	HINGE (R) ASS'Y	79-5100Y-010	
7	SCREW	35-31130-5RA	
8	K/B LOCK KNOB	42-51087-010	
9	SPRING FOR HDD LOCK KNOB	38-00R26-010	
10	K/B LOCK BRACKET FOR TOP CASE	33-51007-010	
11	CABLE FOR M/B-MIC+RUBBER	28-H7J02-50E	
12	CARD BUS DOOR(R)	42-5107P-010	
13	IR LENS	42-51012-010	
14	SPRING(L) FOR CARD BUS DOOR	38-51020-020	
15	CARD BUS DOOR(L)	42-5107P-020	
16	SPEAKER SPONGE	47-5109T-010	
17	SPK+CON	23-C3010-211	
18	SCREW	35-01020-2RE	
19	FFC CABLE	27-9350C-E20	
20	G/P TP-3 LOGITECH	87-62070-081	
21	G/P HOLDER	33-51002-010	
22	TOP CASE ASS'Y	39-51001-010	
23	SPRING(R) FOR CARD BUS DOOR	38-51020-030	

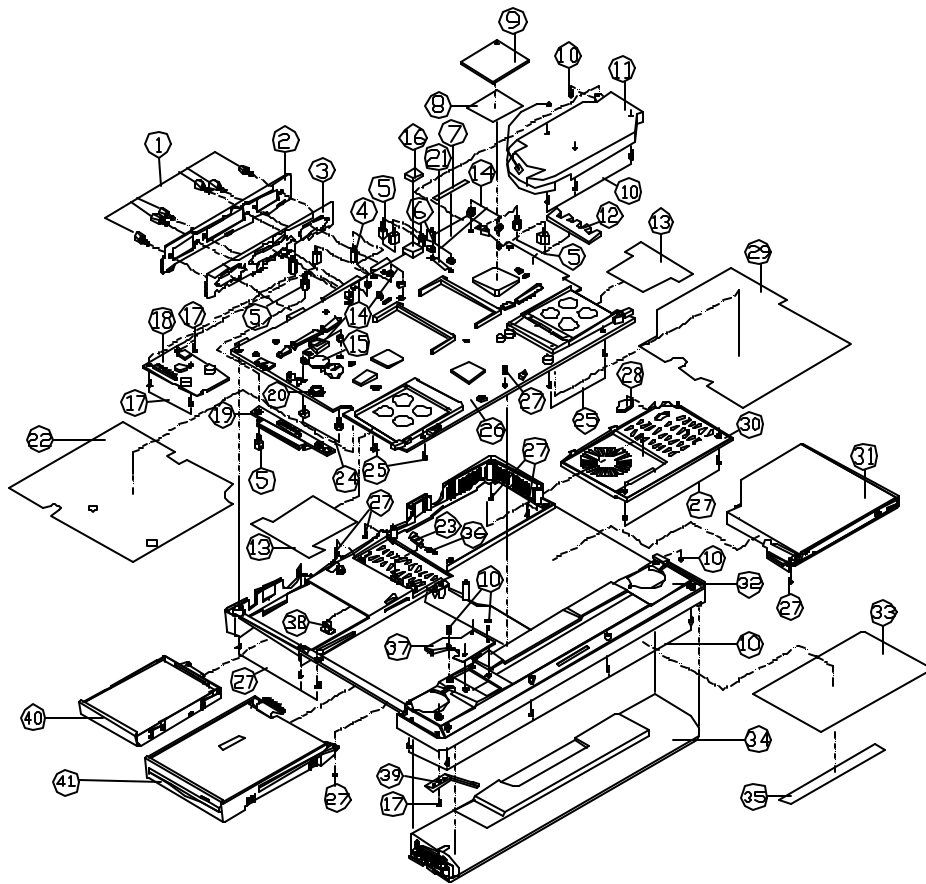

ITEM	PART NAME	PART NO	REMARK
1	HEX STUD(1.5MM)	34-17009-011	
2	REAR BRACKET	33-5100Q-010	
3	SHIELDING PLATE FOR I/O PORT	3B-5102D-051	
4	HEX STUD(1.5MM)	34-5100S-04A	
5	HEX STUD(1.2MM)	34-8500S-03A	
6	LED HOLDER 3P	47-5106S-011	
7	MYLAR FOR CPU SOCKET PINS	41-5101S-130	
8	THERMAL PAD FOR MPE6 IC	47-11M2X-010	
9	NORTH BRIDGE HEATSINK	33-5100S-010	
10	SCREW	35-84125-4RA	
11	HEAT SINK ASS'Y	31-5101N-110	
12	LED SPONGE FOR M/B	47-51092-010	
13	MYLAR FOR CARD BUS	40-5105P-110	
14	NUT SN M2.5	36-05111-250	
15	MYLAR FOR BATTERY	40-8505M-010	
16	SPONGE FOR USB CONN.(M/B)	47-51092-020	
17	SCREW	35-41120-3RA	
18	DC/DC	77-5101C-101	
19	HDD TRANSFER BOARD	77-5100N-101	
20	MYLAR FOR CHARGER(2)	40-3185S-111	
21	MYLAR FOR CPU SOCKET(NEAR)	41-5101S-140	
22	MYLAR FOR M/B(FDD)	40-5105S-020	
23	HDD LOCK	42-85083-111	
24	HEX STUD(2.5MM)	34-5100S-01A	
25	SCREW	35-41120-3RA	
26	MAIN BOARD	77-51011-101	
27	SCREW	35-16125-6RA	
28	BOTTOM CASE RUBBER PAD	47-51023-011	
29	MYLAR FOR M/B(CD-ROM)	40-5100S-010	
30	CPU COVER	42-51173-010	
31	CD-ROM ASS'Y DWG	79-5102Z-011	REFERENCE ASS'Y DWG (79-51000-040)
31	DVD-ROM ASS'Y DWG	79-5102V-110	REFERENCE ASS'Y DWG (79-51000-050)
31	DVD-ROM ASS'Y DWG	79-5102V-120	REFERENCE ASS'Y DWG (79-51000-160)
32	BOTTOM CASE	39-51013-01A	
33	FCC DOC LABEL(NO BRAND)	45-51003-021	
34	BATTERY ASS'Y	7B-5100M-100	Reference Ass'y DWG (79-51000-070)
35	FCC DOC LABEL	45-51013-110	
36	SPRING FOR HDD LOCK KNOB	38-00R26-010	
37	BATTERY BOARD	77-5100Q-101	
38	HDD LOCK KNOB	42-31881-021	
39	K/B SPRING PLATE	3B-35020-011	
40	HDD ASS'Y DWG	79-5102L-110	REFERENCE ASS'Y DWG (79-51000-180)
41	FDD ASS'Y DWG	79-5102J-010	REFERENCE ASS'Y DWG (79-51000-190)
41	LS-120 ASS'Y DWG	79-5102L-010	REFERENCE ASS'Y DWG (79-51000-100)

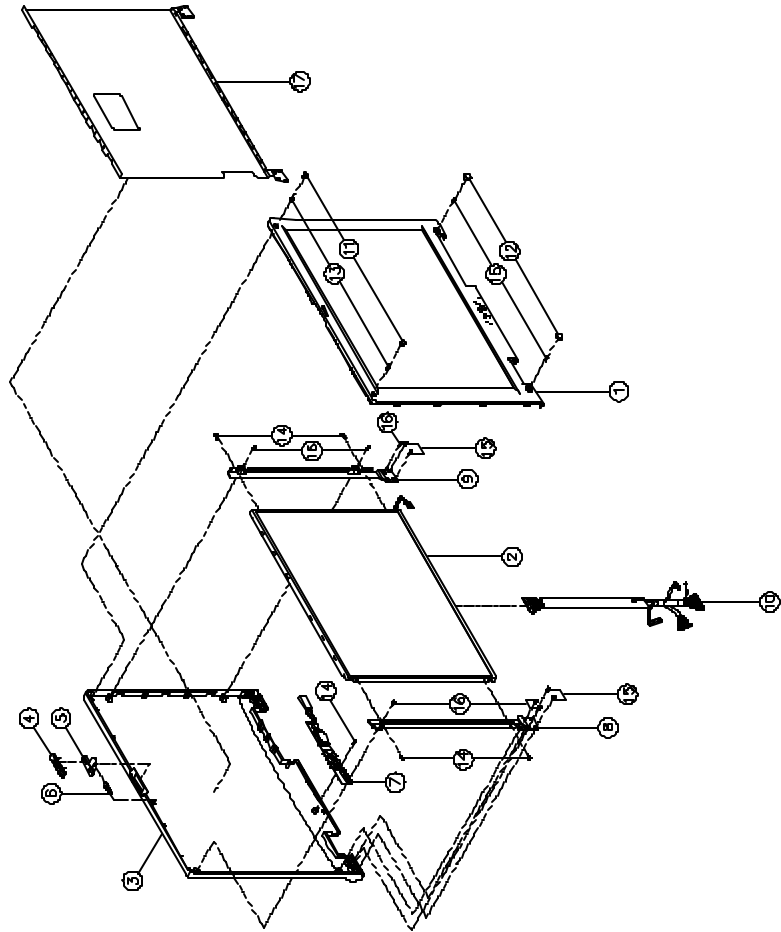

17	LCD SHIELDING PLATE 12.1	33-51001-030	
16	SCREW	35-B6130-4RA	M3*4,K1,BZ,ICT,NY
15	SCREW	35-84130-6RA	M3*6L,K,BK/0,ICT,NY
14	SCREW	35-41120-3RA	M2*0,4P*3L,B,NI,ICT,NY
13	SCREW	35-01120-4R0	M2*4L,P,NI,ICT
12	DISPLAY RUBBER PAD	47-51021-020	BOTTOM
11	DISPLAY RUBBER PAD	47-51021-010	UP
10	CABLE	28-71B35-W20	
9	LCD BRACKET (R)	33-51001-010	FOR LG 12.1
8	LCD BRACKET (L)	33-51001-020	FOR LG 12.1
7	INVERTER	76-21PTR-D10	13.3&14.1 TDK
7	INVERTER	76-21PIR-D10	13.3&14.1 INNSUN
7	INVERTER	76-21PAR-D10	13.3&14.1 AMBIT
6	SPRING	38-10R35-021	
5	HOOK	42-510A1-010	
4	HOOK KNOW	42-51081-010	
3	DISPLAY BACK PANEL	39-51001-02A	FOR LG 12.1
2	LCD (12.1)	50-F5707-66L	
1	DISPLAY FRONT PANEL	39-51001-01A	LG/SY/MI 12.1
ITEM	PART NAME	PART NO.	REMARK

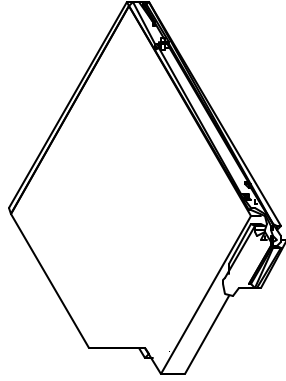

CD-ROM ASSY DVG

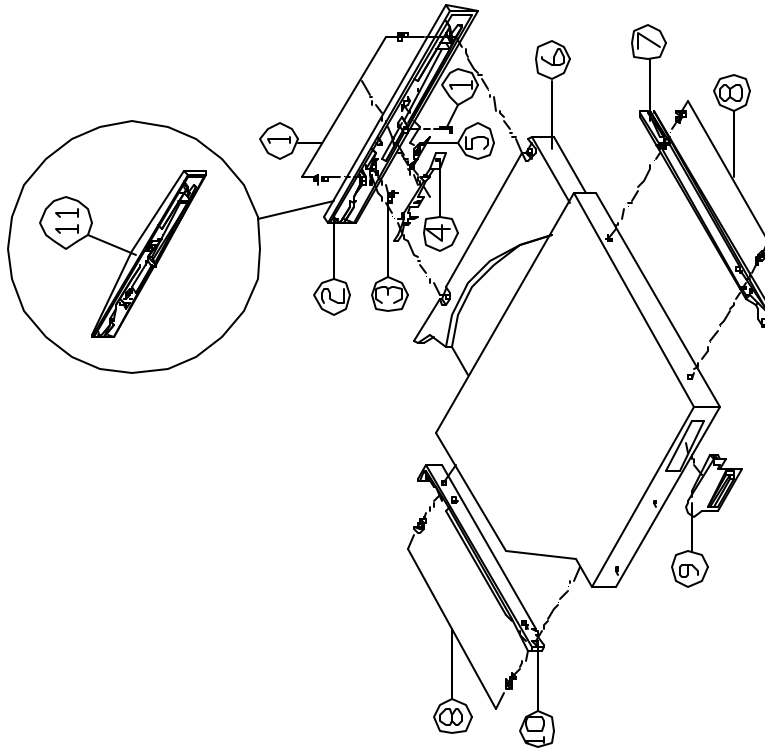

ITEM	PART NAME	PART NO	REMARK
1	SCREW	85-14950-6R1	
2	CD-ROM PANEL	42-51072-00D	TEAC
3	CD-ROM LENS	42-51072-00D	TEAC
4	SPRING PANEL	34-62112-00D	TEAC
5	CD-ROM ELECT. JUNCTION	42-51072-00D	TEAC
6	CD-ROM LE-7MM 24X	D7-92011-004	TEAC
7	CD-ROM GUIDE RAIL(L)	42-1A272-010	TEAC
8	SCREW	25-31201-00A	
9	CD-ROM GUIDE RAIL(R)	42-1A272-010	
10	PEC CABLE	34-70250-02H	
11	TEAC BRAZEL ASSY	79-5101V-01L	

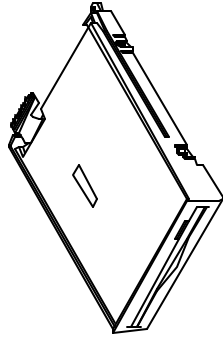
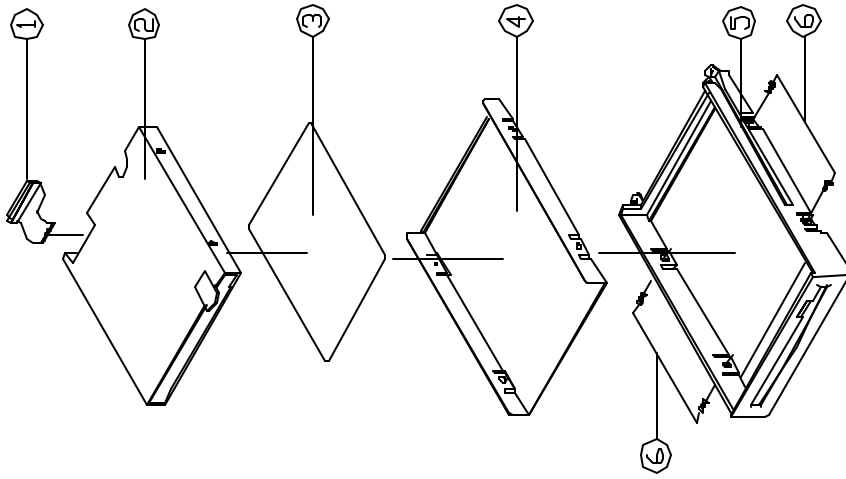

FDD ASS'Y DWG

ITEM	PART NAME	PART NO	REMARK
1	FPC CABEL	28-79K60-280	
2	FDD	85-2321-557-C	TEPC
3	MYLAR FOR FDD	40-8505J-00	
4	FDD BRACKET	33-3100J-D11	
5	FDD CASE	42-5007J-010	
6	SCREW	35-84125-4R4	

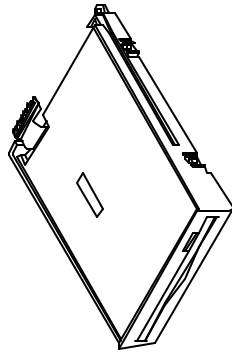
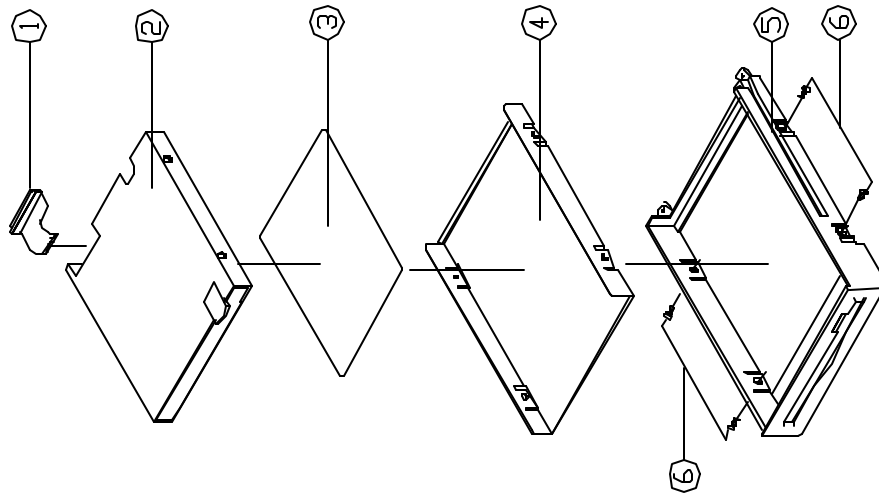

FDD ASS'Y DWG

ITEM	PART	NAME	PART	NO	REMARK
1	FPC CABLE		28-79860-280		
2	3.5" FDD		85-8320-567-C		TEAC
3	MYLAR FOR FDD		40-85051-N0		
4	FDD BRACKET		83-3100J-D11		
5	FDD CASE		43-3107J-010		
6	SCREW		35-84123-4RA		

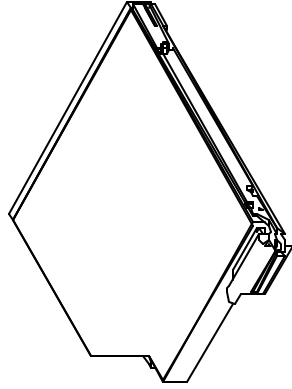
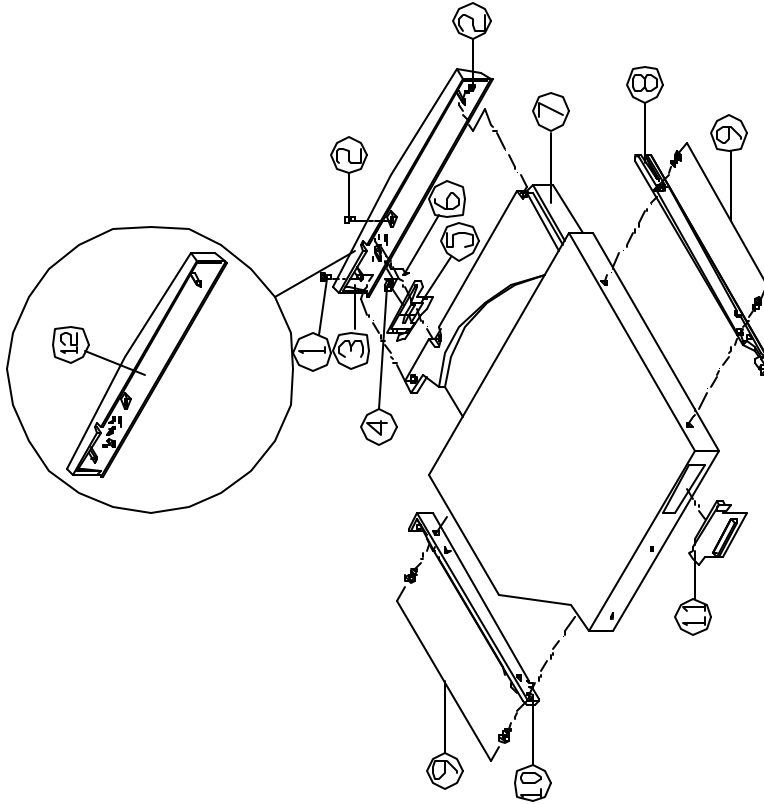

DVD-ROM ASS'Y DWG

ITEM	PART NAME	PART NO	REMARK
1	SCREW	35-B6917-3R15	
2	SCREW	35-84517-3R15	
3	DVD BEZEL	42-5117V-100	PANASONIC
4	DVD KNOB	42-5117V-100	PANASONIC
5	DVD BEZEL PLATE	32-1111V-110	PANASONIC
6	DVD LED LENS	42-5117V-100	PANASONIC
7	DVD-ROM LENS	87-11150-100	PANASONIC
8	DVD-ROM BUJIE RAIL(L)	42-11A7Z-100	
9	SCREW	35-81120-30A	
10	DVD-ROM BUJIE RAIL(R)	42-11A7Z-040	
11	FPC CABLE	28-79K50-330	
12	PANASONIC DVD-ROM ASS'Y	70-5110V-101	

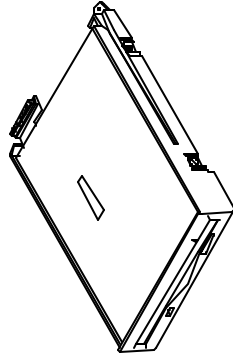
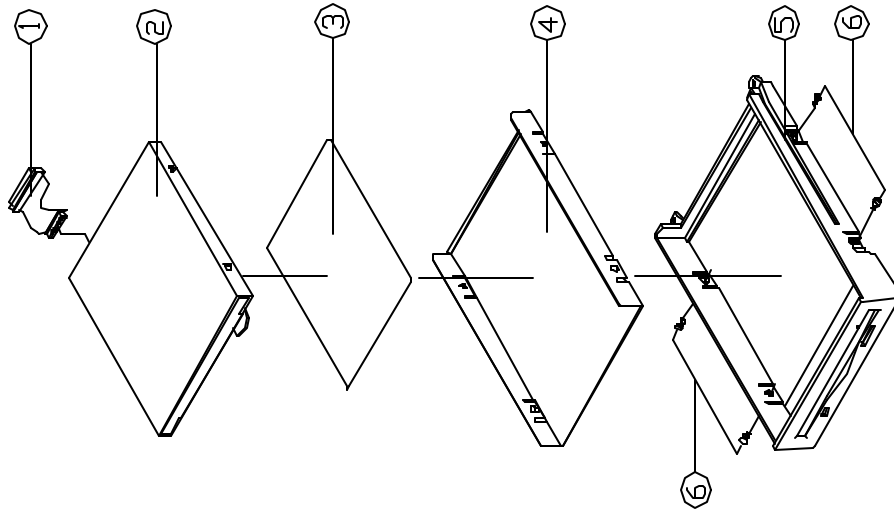

LS-120 ASS'Y DWG

ITEM	PART NAME	PART NO	REMARK
1	FPC CABEL	28-79R60-330	
2	3.5" LS-120	85-60265-58P	
3	FDD MYLAR	40-89DSJ-000	
4	FDD BRACKET	30-5100J-000	
5	CASE FOR LS-120	33-5100L-000	
6	SCREW	35-84123-4RA	

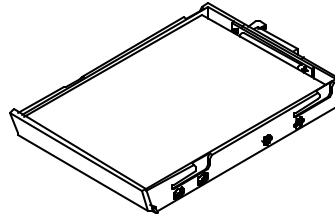
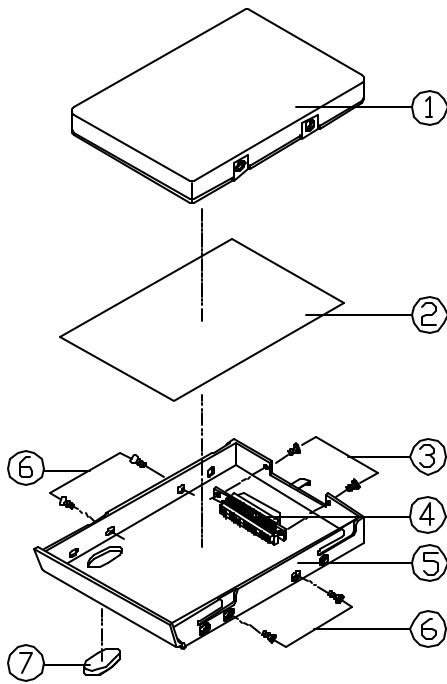

HDD ASS'Y DWG<12.7MM>

ITEM	PART NAME	PART NO	REMARK
1	2.5" HDD <12.7MM>	05-12210-54T	TOSHIBA
1	2.5" HDD <12.7MM>	81-12210-54S	HITACHI
1	2.5" HDD <12.5MM>	05-12210-544	IBM
2	HDD MYLAR	40-6205(-010)	
3	SCREW	35-34125-5RA	
4	FPC CABEL	28-79R4B-050	
5	HDD CASE <12.7MM>	42-51071-010	
6	SCREW	35-36130-4RA	
7	RUBBER PAD	47-51023-010	

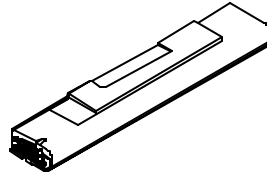
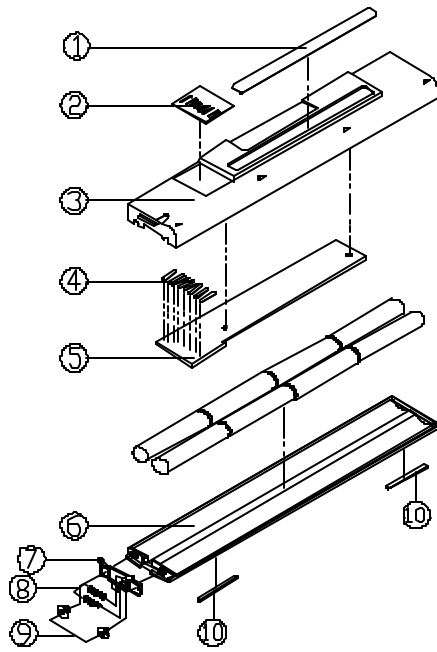

BATTERY PACK ASS'Y

ITEM	PART NAME	PART NO	REMARK
1	BATTERY LABEL	45-3100N-010	
2	INLAY FOR BATTERY CONTACT PLATE	40-3102M-010	
3	BATTERY TOP COVER	42-5107M-010	
4	CONTACT PLATE FOR BATT.	38-5102P-010	
5	BATTERY CONNECTOR BARS	76-3100W-010	
6	BATTERY BOTTOM CASE	42-5107M-020	
7	BATTERY LOCK	42-5107M-020	
8	SPRING FOR BATTERY LOCK	38-5102P-010	
9	SCREW	88-5902P-09E	
10	RUBBER PAD FOR BATTERY THICKNESS	47-5302E-010	

## ③ Optional Parts

### POWER CORD

ITEM	PART NUMBER	DESCRIPTION
1	27-01318-001	POWER CORD 125V 2P (USA)
2	27-01318-004	POWER CORD 125V 2P (ARABIC)
3	27-01318-00A	POWER CORD (ITALIAN)
4	27-01318-00J	POWER CORD 125V 2P (UK)
5	27-01318-00K	POWER CORD 125V 2P (AUSTRALIA)
6	27-01318-00N	POWER CORD 125V 2P (PHILIPPINE)
7	27-01318-00X	POWER CORD 125V 2P (S. AFRICA)
8	27-01318-00Z	POWER CORD 125V 2P (EUROPE)

## KEYBOARD

ITEM	PART NUMBER	DESCRIPTION
1	80-51008-7G1-3	U.S.A K970679AUS
2	80-51008-7G2-3	CHINESE K970679ACH
3	80-51008-7G3-3	DANISH K970679ADT
4	80-51008-7G4-3	ARABIAN K970679AAR
5	80-51008-7G6-3	FRANCE K970679AFR
6	80-51008-7G7-3	GERMAN K970679AGR
7	80-51008-7G8-3	ISRAEL K970679AHB
8	80-51008-7GA-3	ITALY K970679AIT
9	80-51008-7GB-3	KOREAN K970679AKR
10	80-51008-7GC-3	LATIN ROSSIAN K970679ALA
11	80-51008-7GD-3	NORWAY K970679ANW
12	80-51008-7GF-3	PORTUGAL K970679APO
13	80-51008-7GG-3	SPANISH K970679ASP
14	80-51008-7GH-3	SWEDEN K970679ASD
15	80-51008-7GI-3	SWISS K970679ASW
16	80-51008-7GJ-3	U.K. K970679AUK
17	80-51008-7GL-3	JAPANESE K970679AJA
18	80-51008-7GS-3	BELGAN K970679ABE
19	80-51008-7GT-3	TURKISH K970679ATR
20	80-51008-7GU-3	GREEK K970679AGK
21	80-51008-7GW-3	CZECH K970679ACZ
22	80-51008-7G1-1	U.S.A K970679DUS W/O WIN
23	80-51008-7G1-3	U.S.A K970679DUS
24	80-51008-7G1-3	U.S.A K970679A2US
25	80-51008-7G7-3	U.S.A K970679A2GR
26	80-51008-7G1-3	U.S.A K970679A3US