

Specifications

The Notebook Computer is a state-of-the-art, high performance, portable system. It offers a host of features specially designed to enhance performance and usability.

CPU

- Intel Pentium Processors with MMX technology.
- AMD K6 or K6-2 Processors.

Memory

- 3.3V power supply.
- Supports Fast Page Mode/EDO/SDRAM.
- 512KB secondary cache Pipeline Burst Synchronous RAM (PBSRAM).
- 8MB expandable up to 256MB.
- 144-pin SODIMM package.

System BIOS

- 256KB flash ROM.
- PCI 2.1.
- Plug and Play 1.0a.

Display

- 13.3" TFT XGA (1024x768 pixels) LCD panel available.
- 12.1" DSTN/TFT SVGA (800x600 pixels) LCD panel available.
- 4MB SGRAM.
- Video Port Manager (VPM 1.10) for Zoomed Video (ZV) port.
- Simultaneous display with an external monitor.

Mass Storage

- 3.5" floppy diskette drive.
- 2.5" hard disk drive (12.7mm high or less).
- 5.25" CD-ROM.

Audio

- Sound Blaster Pro compatible.
- Stereo full duplex support.
- 3D stereo sound effects.
- Built-in microphone.
- Built-in speakers.

Infrared Wireless Communication (M/B D03 or later version)

- IrDA (HPSIR)

- ASKIR

PC Card Sockets

- One Type III PC card or two Type II PC cards.
- CardBus support.
- One socket ZV (Zoomed Video)-capable.

Input/Output

- Built-in trackpad (PS/2).
- USB port
- External monitor (CRT) port.
- Parallel port.
- Serial port.
- PS/2 type port.
- Microphone-in jack.
- Headphone jack.

Keyboard

- Windows 95.
- Detachable for various language versions.

Power Management

- APM 1.2.
- ACPI.
- Global Standby.
- Suspend and Resume.

Rechargeable Battery Pack

- Ni-MH battery available.
- Li-Ion battery available.
- Battery low warning.
- Auto-switching with AC power adapter.

Size & Weight

- 302mm(w)x249mm(d)x46mm(h).
- 3kg.

Temperature Environment

- Operating 5°C~35°C
- Storage -20°C~60°C

Humidity Environment

- Operating 20%~80%, non-condensing
- Storage 10%~90%, non-condensing

I/O Address Map

Hex Range	Device
000 – 00F	DMA controller-1
020 – 021	Interrupt controller-1
040 – 043	Timer 1
048 – 04B	Timer 2
060 – 06E	KB controller M38813 chip select
070 – 071	RTC and NMI mask
080 – 08F	DMA page register
0A0 – 0A1	Interrupt controller-2
0C0 – 0DF	DMA controller-2
1F0 – 1F7	Fixed disk select
3F6 , 3F7	
2F8 – 2FF	Serial port 2
378 – 37A	Parallel port 1
3B4 , 3B5	CRT controller index (mono)
3D4 , 3D5	CRT controller index (color)
3BA	Feature control
3C0 – 3DA	
3F2 – 3F7	Floppy disk controller
3F0 , 3F1	Configuration port
3F8 – 3FF	Serial port 1

System Memory Map

Address	Size	Function
000000 – 09FFFF	640KB	640KB Base Memory
0A0000 – 0BFFFF	128KB	Video RAM
0C0000 – 0CBFFF	48KB	VGA BIOS
0CC000 – 0DFFFF	80KB	Reserved
0E0000 – 0EFFFF	64KB	System BIOS for SCU, PCI, PnP, PMU
0F0000 – 0FFFFFFF	64KB	System BIOS for Kernal
100000 –	16MB to 256MB	Extended Memory

System Resource Allocation

DMA s	Devices
0	Available
1	Audio
2	Floppy Disk
3	ECP
4	Cascade
5	Available
6	Available
7	Available

IRQ s	Devices
IRQ0	Timer
IRQ 1	Keyboard
IRQ 2	Cascade
IRQ 3	Infrared
IRQ 4	COM1
IRQ 5	Audio/MPU-401
IRQ 6	Floppy Disk
IRQ 7	Parallel Port
IRQ8	Real Time Clock
IRQ9	Available
IRQ10	PCMCIA
IRQ11	PCMCIA
IRQ12	Trackpad (PS/2)
IRQ13	Floating Point Unit
IRQ14	Primary IDE Interface (HDD)
IRQ15	Secondary IDE Interface (CD-ROM)

Motherboard

The motherboard is designed mainly based Pentium(MMX) CPU and the INTEL 430TX Chipset: 82C439TX, 82C371EB; it includes the following features:

- ✓ INTEL 430TX chipset solution from INTEL
- ✓ S3 86C260 Multimedia Flat Panel Controller
- ✓ PCI Local Bus IDE interface
- ✓ SMC669IR super I/O Floppy Disk Controller
- ✓ M38867 Keyboard Controller
- ✓ Flash EPROM 256KB with SystemSoft system BIOS, VGA BIOS
- ✓ DRAM Upgradable to 128MB
- ✓ 7 DMA channels
- ✓ 13 interrupt levels
- ✓ Real Time clock / calendar, battery back up
- ✓ Speaker for sound system
- ✓ Built-in 3D Stereo Audio subsystem
- ✓ Port connectors :
 - 9 pin serial (COM1)
 - 25 pin Parallel Printer Port (LPT1)
 - 15 pin external monitor port
 - 6 pin external keyboard port
 - 4 pin USB Port

Microprocessor

Intel Pentium Processors with MMX Technology

Features included:

- ✓ Superscalar architecture.
- ✓ Separate code and data caches.
- ✓ Branch prediction.
- ✓ High performances floating point unit.
- ✓ Enhanced 64 bits data bus.
- ✓ Data integrity features.
- ✓ SL technology power management features.
- ✓ Multiprocessing support.
- ✓ Performance monitoring.
- ✓ Memory page size feature.

AMD K6 or k6-2 Processors

The AMD-K6 processor is available in clock speeds of 300, 266 MHz. The AMD-K6 is equipped with x86 instruction set multimedia extensions and brings sixth-generation performance and MMX enhanced capability using the optimum performance provided by the existing, low-cost Socket 7 infrastructure.

CPU Core Frequency Settings

The correct configuration for CPU core frequency is listed as follows:

Intel Pentium Processor at 3.3V I/O Voltage										
CPU Frequency	1	2	3	4	5	6	7	8	9	10
120 MHz	X	X	On	On	Off	On	Off	Off	Off	Off
133 MHz	X	X	On	Off	Off	On	Off	Off	Off	Off
150 MHz	X	X	On	On	Off	On	On	Off	Off	Off
166 MHz	X	X	On	Off	Off	On	On	Off	Off	Off
200 MHz	X	X	On	Off	Off	Off	On	Off	Off	Off
233 MHz	X	X	On	Off	Off	Off	Off	Off	Off	Off

Intel Pentium Processor at 2.5V I/O Voltage										
CPU Frequency	1	2	3	4	5	6	7	8	9	10
200 MHz	X	X	On	Off	Off	Off	On	On	Off	On
233 MHz	X	X	On	Off	Off	Off	Off	On	Off	On
266 MHz	X	X	Off	Off	Off	On	On	Off	Off	On

AMD K6 or K6-2 Processor										
CPU Frequency	1	2	3	4	5	6	7	8	9	10
266 MHz	X	X	On	Off	Off	On	Off	On	Off	Off
300 MHz	X	X	On	Off	Off	On	On	On	Off	Off

Chips

Core Logic – Intel 430TX
82439TX/82C371EB

- ✓ Support for Intel Pentium(MMX) , with bus speed up to 66MHz
- ✓ Support for both symmetric and asymmetric type DRAM
- ✓ High Performance Memory Controller
- ✓ Enhanced hidden refresh
- ✓ Support for Fast Page mode, EDO type, and Synchronous type DRAM
- ✓ EDO RAM and SDRAM automatic detect mode
- ✓ 430TX supports two bus mastering IDE channels (with Ultra DMA)
- ✓ Supports the Pentium processor family host bus at 66 MHz and 60 MHz at 3.3V and 2.5V.
- ✓ Serial IRQs supported
- ✓ Synchronous SRAM clock control to reduce power consumption
- ✓ Stop Grant, stop clock for 1X clock scaling
- ✓ PCI local bus support
- ✓ Flash EPROM support
- ✓ Screen activity detect
- ✓ Programmable suspend and resume (POS,STR,STD)
- ✓ Automatic suspend timer
- ✓ System activities and programmable clock speed control
- ✓ Programmable system event
- ✓ Programmable stop break event
- ✓ Intel SL compatible shadow registers

VGA Controller – S3 86C260

The S3 86C260 Multimedia Flat Panel Controller is a high performance, highly integrated 2D/3D Graphics and multimedia display controller. It contains the following functions:

- ✓ Displays memory support 83MHZ SGRAM
- ✓ 33 MHZ PCI 2.1 Bus Master
- ✓ Flat and Gouraud shading for 3D
- ✓ High quality 3D texture mapping
- ✓ 16-bit hardware Z-buffering
- ✓ Different images simultaneously on different displays
- ✓ ZV Port compliant
- ✓ 3.3V operation with 5.0V tolerance
- ✓ Fully ACPI compliant
- ✓ DPMS and DDC monitor communication for Green PC and CRT Plug and Play support
- ✓ Industry leading DuoView simultaneous display
- ✓ supports 16/24 bit color DSTNs up to 1024x768x16M color, and TFT panels up to 1280x1024x64K color
- ✓ supports non-interlaced 1024x768x16M, 800x600x16M, and 640x480x16M color on CRT

PC CARD Interface Controller - TI1220

TI CardBus Interface Controller 1220 implements the PCMCIA 2.0/JEIDA 4.1 standard. It contains the following functions:

- ✓ PCI interface Specification 2.1
- ✓ Supports Zoom Video Mode
- ✓ PCMCIA dual-socket interface
- ✓ PCI Power Management compliant
- ✓ ACPI compliant
- ✓ Fully compatible with the Intel 430TX chipset
- ✓ Five programmable memory windows per socket
- ✓ 1995 PC Card Standard compliant
- ✓ Supports two PC Card or CardBus Slots with hot insertion and removal
- ✓ Advanced submicron, low-power CMOS technology
- ✓ Two I/O windows per socket
- ✓ ATA disk interface support
- ✓ Programmable suspend mode
- ✓ Automatic flash memory timing support
- ✓ ExCA-compatible register are mapped in memory or I/O space

ZV Port Custom Interface

The ZV (Zoomed Video) Port is a single source, point-to-point uni-directional video bus between a PC card socket and a VGA controller. The ZV Port complies with CCIR601 timing to allow NTSC decoders to deliver real-time digital video straight into the VGA frame buffer from a PC card. The ZV Port also allows an industry standard mechanism for transferring digital audio PCM data to a low cost DAC for conversion to an analog signal.

Super I/O FDD Controller – SMC669IR

The SMC's 669IR super I/O is optimized for motherboard applications. It provides:

- ✓ Intelligent auto power management
- ✓ 16 Bit address qualification (optional)
- ✓ 2.88MB Super I/O Floppy Disk Controller
 - Support Vertical Recording Format
 - 16 Byte Data FIFO
 - Enhanced Digital Data Separator. Data rate up to 1Mb/s.
- ✓ Multi-Mode Parallel Port with ChiProtect Circuitry
 - Standard Mode
IBM PC/AT and PS/2 compatible bi-directional parallel port.
 - Enhanced Mode
Enhanced Parallel Port (EPP) compatible
 - High Speed Mode
Microsoft and Hewlett Packard Extended Capabilities Port (ECP) compatible
- ✓ Serial Port
 - Two high speed NS16C550 compatible UARTs with Send/Receive 16 Byte FIFOs
 - Programmable Baud Rate Generator
 - Supports 230K and 460K Baud
 - Modem Control Circuitry

High Quality Audio Chip – ESS ES1869

- ✓ Single, high-performance, mixed-signal, 16-bit stereo VLSI chip
- ✓ High-quality, 20-voice ESFM music synthesizer
- ✓ Patented ESPCM compression
- ✓ High-performance DMA supports Demand Transfer and F-type
- ✓ Internal configuration data for audio Plug and Play support
- ✓ Read/Write serial interface for Plug and Play resource EEPROM
- ✓ Record, compress, and play back voice, sound, and music
- ✓ 16-bit stereo ADC and DAC
- ✓ Programmable sample rates from 4 kHz to 44.1 kHz for record and playback
- ✓ Full-duplex operation for simultaneous record and playback

Enhanced Universal Serial BUS (USB) Controller

The PIIX4 USB controller provides enhanced support for the Universal Host Controller Interface (UHCI). This allows legacy software to use a USB-based keyboard and mouse.

Keyboard Controller - M38867E8HP

- ✓ Memory size: 1024 bytes(RAM)/32K bytes(ROM)
- ✓ Timers: 8 bit timer X 4 , 8 bit prescalers X 3
- ✓ Comparator: 8 channels
- ✓ The minimum instruction execution time: 0.5us (8MHZ)
- ✓ Clock Generating Circuit: 2 clock generating circuits
- ✓ Interrupts: 21 sources, 16 vectors
- ✓ Multi-Master IIC-bus/SMBus(option): 1 channel

L2 Cache Size

Cache Size	Data RAM	Tag RAM	Cacheable Size (8-bits tag)
512KB	64Kx32x2	32Kx8	64MB

L2 Cache Speed Synchronous SRAM

Cache Configuration	60MHz (tag/data)	66MHz (tag/data)
Read 3-1-1-1 Write 3-1-1-1	12ns/9ns	12ns/9ns

DRAM Speed

The speed ratings of DRAM for various CPU external clock rates are listed below (using 1Mx16, 4Mx16 or 8Mx8 memory):

DRAM Speed	60MHz (clocks)	66MHz (clocks)
60ns	read x-3-3-3	write x-3-3-3
60ns	write x-2-2-2	write x-2-2-2

Refresh cycle (with CAS-BEFORE-RAS Refresh Cycle) = 2K

FPM/EDO : speed at 60ns or faster

SDRAM : speed at 75MHz or faster

Pin Configurations

Floppy Disk Drive Interface

The Notebook PC uses one 26-pin FFC connector to interface with the built-in 1.44MB 3.5" disk drive. The pin configuration is:

Pin	Description	Pin	Description
1	VCC	2	INDEX#
3	VCC	4	DRV0#
5	VCC	6	DSKCHG#
7	N.C.	8	N.C.
9	3MODE#	10	MTR0#
11	N.C.	12	DIR#
13	N.C.	14	STEP#
15	GND	16	WDATA#
17	GND	18	WGATE#
19	GND	20	TRK0#
21	GND	22	WP-FD#
23	GND	24	RDATA#
25	GND	26	HDSEL#

Hard Disk Drive Interface

The Notebook PC has a standard PC/AT interface (IDE) which can directly interface with any hard disk drive with an embedded controller supporting the same PC/AT interface through the use of a 44-pin pin header connector. The 44-pin connector has the following pin configurations:

Pin	Description	Pin	Description
1	HDRST#	2	GND
3	DDP7	4	DDP8
5	DDP6	6	DDP9
7	DDP5	8	DDP10
9	DDP4	10	DDP11
11	DDP3	12	DDP12
13	DDP2	14	DDP13
15	DDP1	16	DDP14
17	DDP0	18	DDP15
19	GND	20	N.C.
21	PDREQ	22	GND
23	PDIOW#	24	GND
25	PDIOR#	26	GND
27	PIORDY	28	GND
29	PDAK#	30	GND
31	IRQ14	32	N.C.
33	PDA1	34	N.C.
35	PDA0	36	PDA2
37	CS1P#	38	CS3P#
39	HD-LED#	40	GND
41	VCC	42	VCC
43	GND	44	N.C.

RS-232C Serial Interface

The Notebook PC has one RS-232C serial port which enables users to connect a serial printer, a serial mouse, a plotter, a modem, etc. The key features of the serial port are listed as follows:

- ✓ IBM PC/AT compatible.
- ✓ Compatible with NS16C550.
- ✓ Individual modem control/signals for each channel.
- ✓ Programmable serial interface characteristics:
 - 5-, 6-, 7-, or 8-bit characters.
 - Even, odd, or no parity bit generation and detection.
 - 1, 1 ½, or 2 stop bit generation.
 - Tri-state TTL drives capabilities for bi-directional data bus and control bus.

The RS-232C serial port uses a 9-pin D-sub male connector which has the following pin configurations:

Pin	Description
1	DCD (DATA Carrier Detect)
2	RXD (Received Data)
3	TXD (Transmitted Data)
4	DTR (Data Terminal Ready)
5	GND (Signal Ground)
6	DSR (Data Set Ready)
7	RTS (Request To Send)
8	CTS (Clear To Send)
9	RI (Ring Indicator)

Parallel Interface

The parallel interface is implemented using a 25-pin D-sub female connector which has the following pin configurations:

Pin	Description	Pin	Description
1	Strobe#	2	Data 0
3	Data 1	4	Data 2
5	Data 3	6	Data 4
7	Data 5	8	Data 6
9	Data 7	10	ACK#
11	Busy	12	Paper Empty
13	Select	14	Auto Linefeed#
15	Error#	16	Initialize#
17	Select In	18	Ground
19	Ground	20	Ground
21	Ground	22	Ground
23	Ground	24	Ground
25	Ground		

Expansion Memory Socket

Socket 1:

Pin	Description	Pin	Description	Pin	Description
1	GND	2	GND	3	MD0
4	MD32	5	MD1	6	MD33
7	MD2	8	MD34	9	MD3
10	MD35	11	MEM-VCCA	12	MEM-VCCA
13	MD4	14	MD36	15	MD5
16	MD37	17	MD6	18	MD38
19	MD7	20	MD39	21	GND
22	GND	23	ICAS#0	24	ICAS#4
25	ICAS#1	26	ICAS#5	27	MEM-VCCA
28	MEM-VCCA	29	IMA0	30	IMA3
31	IMA1	32	IMA4	33	IMA2
34	IMA5	35	GND	36	GND
37	MD8	38	MD40	39	MD9
40	MD41	41	MD10	42	MD42
43	MD11	44	MD43	45	MEM-VCCA
46	MEM-VCCA	47	MD12	48	MD44
49	MD13	50	MD45	51	MD14
52	MD46	53	MD15	54	MD47
55	GND	56	GND	57	N.C
58	N.C	59	N.C	60	N.C
61	MEMCLK1	62	CKE	63	MEM-VCCA
64	MEM-VCCA	65	SRAS#	66	SCAS#
67	IMWE#	68	CKE	69	IRAS#0
70	IMA12	71	IRAS#1	72	IMA13
73	GND	74	MEMCLK2	75	GND
76	GND	77	N.C	78	N.C
79	N.C	80	N.C	81	MEM-VCCA
82	MEM-VCCA	83	MD16	84	MD48
85	MD17	86	MD49	87	MD18
88	MD50	89	MD19	90	MD51
91	GND	92	GND	93	MD20
94	MD52	95	MD21	96	MD53
97	MD22	98	MD54	99	MD23
100	MD55	101	MEM-VCCA	102	MEM-VCCA
103	IMA6	104	IMA7	105	IMA8
106	IMA11	107	GND	108	GND
109	IMA9	110	IMA12	111	IMA10
112	N.C	113	MEM-VCCA	114	MEM-VCCA
115	ICAS#2	116	ICAS#6	117	ICAS#3
118	ICAS#7	119	GND	120	GND
121	MD24	122	MD56	123	MD25
124	MD57	125	MD26	126	MD58
127	MD27	128	MD59	129	MEM-VCC
130	MEM-VCCA	131	MD28	132	MD60
133	MD29	134	MD61	135	MD30
136	MD62	137	MD31	138	MD63
139	GND	140	GND	141	SMBDA
142	SMBCL	143	MEM-VCCA	144	MEM-VCCA

Socket 2:

Pin	Description	Pin	Description	Pin	Description
1	GND	2	GND	3	MD0
4	MD32	5	MD1	6	MD33
7	MD2	8	MD34	9	MD3
10	MD35	11	MEM-VCCB	12	MEM-VCCB
13	MD4	14	MD36	15	MD5
16	MD37	17	MD6	18	MD38
19	MD7	20	MD39	21	GND
22	GND	23	ICAS#0	24	ICAS#4
25	ICAS#1	26	ICAS#5	27	MEM-VCCB
28	MEM-VCCB	29	IMA0	30	IMA3
31	IMA1	32	IMA4	33	IMA2
34	IMA5	35	GND	36	GND
37	MD8	38	MD40	39	MD9
40	MD41	41	MD10	42	MD42
43	MD11	44	MD43	45	MEM-VCCB
46	MEM-VCCB	47	MD12	48	MD44
49	MD13	50	MD45	51	MD14
52	MD46	53	MD15	54	MD47
55	GND	56	GND	57	N.C
58	N.C	59	N.C	60	N.C
61	MEMCLK3	62	CKE	63	MEM-VCCB
64	MEM-VCCB	65	SRAS#	66	SCAS#
67	IMWE#	68	CKE	69	IRAS#2
70	IMA12	71	IRAS#3	72	IMA13
73	GND	74	MEMCLK4	75	GND
76	GND	77	N.C	78	N.C
79	N.C	80	N.C	81	MEM-VCCB
82	MEM-VCCB	83	MD16	84	MD48
85	MD17	86	MD49	87	MD18
88	MD50	89	MD19	90	MD51
91	GND	92	GND	93	MD20
94	MD52	95	MD21	96	MD53
97	MD22	98	MD54	99	MD23
100	MD55	101	MEM-VCCB	102	MEM-VCCB
103	IMA6	104	IMA7	105	IMA8
106	IMA11	107	GND	108	GND
109	IMA9	110	IMA12	111	IMA10
112	N.C	113	MEM-VCCB	114	MEM-VCCB
115	ICAS#2	116	ICAS#6	117	ICAS#3
118	ICAS#7	119	GND	120	GND
121	MD24	122	MD56	123	MD25
124	MD57	125	MD26	126	MD58
127	MD27	128	MD59	129	MEM-VCCB
130	MEM-VCCB	131	MD28	132	MD60
133	MD29	134	MD61	135	MD30
136	MD62	137	MD31	138	MD63
139	GND	140	GND	141	SMBDA
142	SMBCL	143	MEM-VCCB	144	MEM-VCCB

Internal Trackpad Interface

There is a connector used to interface with the internal trackpad. It should be disabled when external serial mouse has been installed. The trackpad is hardware-connected to PS/2 port, hardware-compatible to Microsoft PS/2 mouse and software-compatible to Microsoft mouse mode. The following is the pin configurations for the connector:

Pin	Description
1	VCC
2	PS/2 DATA
3	PS/2 CLK
4	GND

External Monitor Interface

Pin	Description
1	RED
2	GREEN
3	BLUE
4	N.C
5	GND
6	GND
7	GND
8	GND
9	N.C
10	GND
11	N.C
12	DDCDATA
13	HSYNC
14	VSNC
15	DDCCLK

RGB Out

Output Impedance : 75Ω

RGB peak voltage : 0.7Vpp

External Keyboard/PS2 Mouse Interface

Pin	Description
1	EKDA
2	EMDA
3	GND
4	VCC
5	EKCLK
6	EMCLK

External USB (Universal Serial Bus) Interface

Pin	Description
1	V1+OUT
2	VD1-N
3	VD1-P
4	GND

PCMCIA CardBus Interface

Socket A:

Pin	Description	Pin	Description
1	GND	35	GND
2	A-CD3	36	A-CD1#
3	A-CD4	37	A-CD11
4	A-CD5	38	A-CD12
5	A-CD6	39	A-CD13
6	A-CD7	40	A-CD14
7	A-CE1#	41	A-CD15
8	A-CA10	42	A-CE2#
9	A-OE#	43	A-VS1
10	A-CA11	44	A-IORD#
11	A-CA9	45	A-IOWR#
12	A-CA8	46	A-CA17
13	A-CA13	47	A-CA18
14	A-CA14	48	A-CA19
15	A-WE#	49	A-CA20
16	A-RDYBY#	50	A-CA21
17	A-VCC-C	51	A-VCC-C
18	A-VPP	52	A-VPP
19	A-CA16	53	A-CA22
20	A-CA15	54	A-CA23
21	A-CA12	55	A-CA24
22	A-CA7	56	A-CA25
23	A-CA6	57	A-VS2
24	A-CA5	58	A-RESET
25	A-CA4	59	A-WAIT#
26	A-CA3	60	A-INPACK
27	A-CA2	61	A-REG#
28	A-CA1	62	A-BVD2#
29	A-CA0	63	A-BVD1#
30	A-CD0	64	A-CD8
31	A-CD1	65	A-CD9
32	A-CD2	66	A-CD10
33	A-WP#	67	A-CD2#
34	GND	68	GND

Socket B:

Pin	Description	Pin	Description
1	GND	35	GND
2	B-CD3	36	B-CD1#
3	B-CD4	37	B-CD11
4	B-CD5	38	B-CD12
5	B-CD6	39	B-CD13
6	B-CD7	40	B-CD14
7	B-CE1#	41	B-CD15
8	B-CA10	42	B-CE2#
9	B-OE#	43	B-VS1
10	B-CA11	44	B-IORD#
11	B-CA9	45	B-IOWR#
12	B-CA8	46	B-CA17
13	B-CA13	47	B-CA18
14	B-CA14	48	B-CA19
15	B-WE#	49	B-CA20
16	B-RDYBY#	50	B-CA21
17	B-VCC-C	51	B-VCC-C
18	B-VPP	52	B-VPP
19	B-CA16	53	B-CA22
20	B-CA15	54	B-CA23
21	B-CA12	55	B-CA24
22	B-CA7	56	B-CA25
23	B-CA6	57	B-VS2
24	B-CA5	58	B-RESET
25	B-CA4	59	B-WAIT#
26	B-CA3	60	B-INPACK
27	B-CA2	61	B-REG#
28	B-CA1	62	B-BVD2#
29	B-CA0	63	B-BVD1#
30	B-CD0	64	B-CD8
31	B-CD1	65	B-CD9
32	B-CD2	66	B-CD10
33	B-WP#	67	B-CD2#
34	GND	68	GND

LCD Interface

Pin	Description	Pin	Description
1	GND	2	GND
3	SHFCLK	4	LP
5	GND	6	GND
7	M	8	FLM
9	PP0	10	PP1
11	PP2	12	PP3
13	VCC	14	VCC
15	VCC	16	VCC
17	PP4	18	PP5
19	PP6	20	PP7
21	VCC3	22	VCC3
23	VCC3	24	VCC3
25	PP8	26	PP9
27	PP10	28	PP11
29	AA-VCC	30	AA-VCC
31	PP12	32	PP13
33	PP14	34	PP15
35	AB-VCC	36	AB-VCC
37	PP16	38	PP17
39	PP18	40	PP19
41	100DVCC	42	100DVCC
43	PP20	44	PP21
45	PP22	46	PP23
47	TxVCC	48	TxVCC
49	PP24	50	PP25
51	PP26	52	PP27
53	TxAVCC	54	TxAVCC
55	PP28	56	PP29
57	GND	58	GND
59	PP30	60	PP31
61	TxPVCC	62	TxPVCC
63	PP32	64	PP33
65	PP34	66	PP35
67	LCDVDD	68	LCD-ADJ
69	LCDVDD	70	LCDVDD
71	VD12	72	VD13
73	VD14	74	VD15
75	ACIN	76	BATON
77	DEDGE	78	CEGE
79	TEST	80	HALFCK
81	SUPV	82	EXT-RES
83	CONTADJ	84	BRIGADJ
85	ENABKKL	86	ENAVEE
87	BATFULL	88	BATCHA
89	BAT-BEEP	90	HD-LED
91	SUS-LED	92	FPPOL
93	GND	94	GND
95	PD	96	LID
97	N.C.	98	N.C.
99	B+	100	B+

Flash ROM BIOS

The DIP Switch needed to be set in the **On** position when updating the existing system BIOS. The DIP Switches should be reset to the **Off** position after BIOS updating is complete.

Flash ROM BIOS	SW1-1	SW1-2
Existing BIOS	Off	Off
Updating BIOS	On	On

Hot Keys

Hot Keys	System Features	Remark
Fn + F3	Expand LCD display	
Fn + F6	Toggle LCD/CRT/LCD+CRT	
Fn + F9	Decrease LCD brightness	
Fn + F10	Increase LCD brightness	
Fn + F11	Decrease audio volume	
Fn + F12	Increase audio volume	
Fn + Z	Toggle audio mute on/off	
Fn + Esc	Put the system in a suspend state for power management	

DC / DC Converter

Input Characteristics

Inout Voltage from AC adapter 9.0 ~ 21V
 from battery 12V

Efficiency

The total efficiency is 85% minimum at full load condition.

Output Characteristics

+5V and +3.45V power on simultaneously.

Voltage	Regulation	Ripple & Noise	Current Typical	Current Peak
+ 5 V	- 4% ~ +2 %	150mVp-p	3.0A	4.0 A
+3.45 V	- 4% ~ +2 %	150mVp-p	1.5A	1.65 A
+ 12 V	- 5% ~ +5%	200mVp-p	0.22A	0.4 A

System Alarm

Type	Battery Low	Shut Down
Li-Ion	9.8 V \pm 0.3V	8.8 V \pm 0.3V
Ni-MH	11 V \pm 0.3V	10 V \pm 0.3V

CPU Connector Pin Configurations

The CPU power board use one 20 pin connector **CN1**.

The pin configuration is:

Pin	Description	Pin	Description
1	B++	2	B++
3	B++	4	B++
5	B++	6	B++
7	B++	8	B++
9	B++	10	B++
11	GND	12	GND
13	GND	14	GND
15	GND	16	GND
17	GND	18	GND
19	V++	20	CPU-OFF

The CPU power board use one 30 pin connector **CN2**.

The pin configuration is:

Pin	Description	Pin	Description
1	VCC2	2	VCC2
3	VCC2	4	VCC2
5	VCC2	6	VCC2
7	VCC2	8	VCC2
9	VCC2	10	VCC
11	GND	12	GND
13	GND	14	GND
15	GND	16	GND
17	GND	18	GND
19	GND	20	GND
21	GND	22	GND
23	CPU-IO	24	CPU-IO
25	CPU-IO	26	CPU-IO
27	GND	28	GND
29	GND	30	GND

Charger Connector Pin Configurations

The charger board use one 34 pin connector **CN1**.

The pin configuration is:

Pin	Description	Pin	Description
1	B+	2	B+
3	B+	4	B+
5	B+	6	B+
7	BAT	8	BAT
9	BAT	10	BAT
11	BAT	12	BAT
13	GND	14	GND
15	GND	16	GND
17	GND	18	BATCHA
19	GND	20	BATFULL
21	F	22	BAT-CLK
23	A	24	BAT-DATA
25	TEMP	26	GND
27	GND	28	GND
29	GND	30	CCO
31	CCO	32	CCO
33	A++	34	FBO

Inverter

1. LED1, LED2 → GREEN/RED
LED3~LED6 → GREEN/RED

2. DIP 15-Pin Connector (Pin Assignment):

1. B+
2. B+
3. GND
4. GND
5. BRIGADJ
6. BKLO
7. BATFULL
8. BATCHA
9. BAT_BEEP
10. ACIN
11. BATON
12. HDD_LED
13. SUS_LED
14. X
15. X

3. Lamp Current

$1.8 \pm 0.2 \text{ mA} \sim 5.0 \sim 5.5 \text{ mA rms}$

4. Lamp Voltage

700 Vrms

5. Starting Voltage

1400 Vrms @ 0°C

6. Freq : 30 ~ 80 KHZ

7. BRIGADJ (Brightness) : 0 ~ 2.5 V

8. B+ : 7 ~ 22 V

9. BKLO : 3.3 V (ON) ; 0V (OFF); Hi of t • 15ms is low

10. Temperature Rise:

Temperature Rise under 30°C

Max. operation temperature 65°C

System Block Diagram

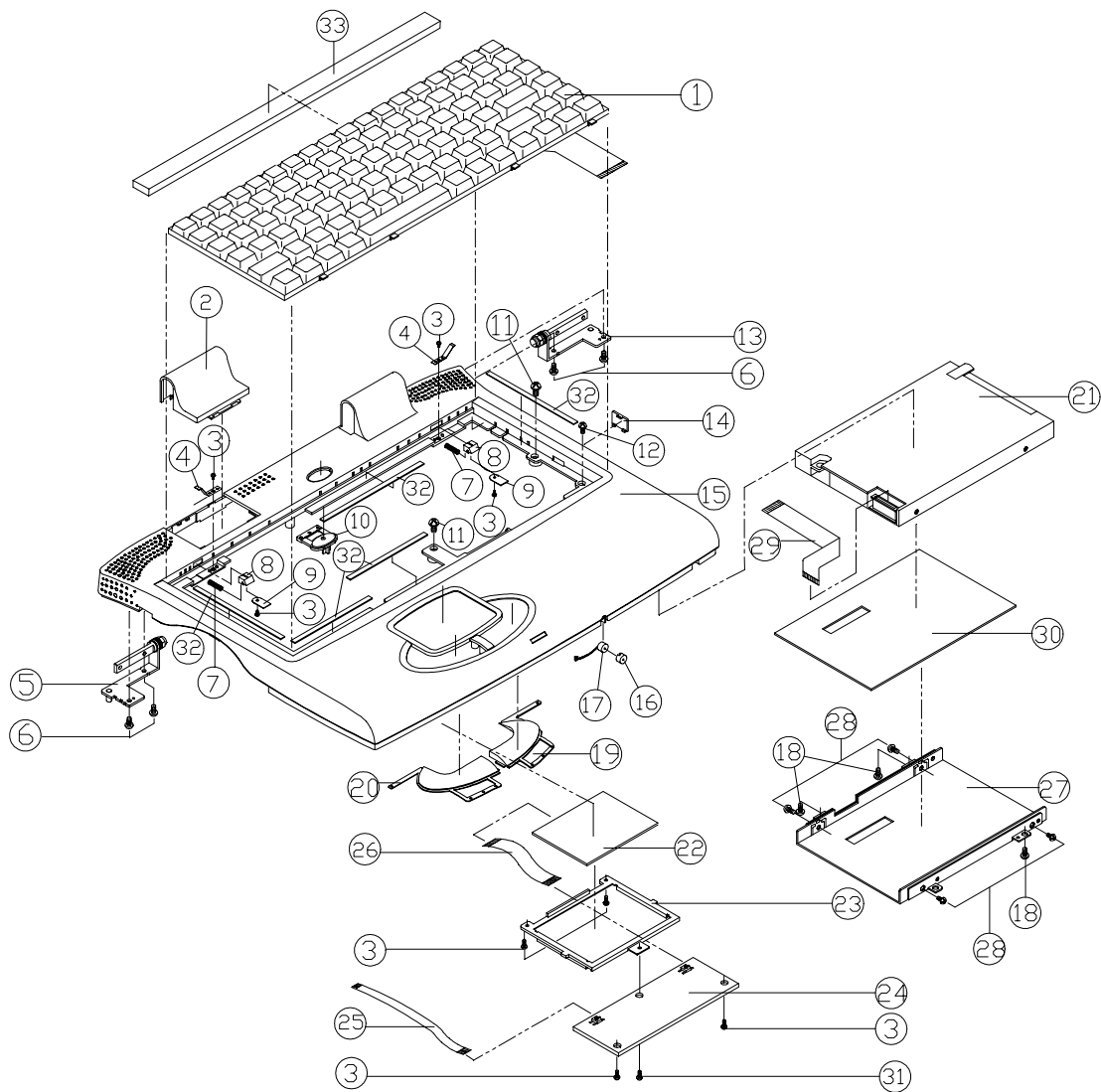

ITEM	PART NAME	PART NO	REMARK
1	KEYBOARD FOR 1100	80-11A08-7G0	
2	CONNECTOR COVER	42-11A72-011	
3	SCREW	35-41120-3RA	
4	K/B SPRING PLATE	38-35020-010	
5	HINGE(L) ASS'Y	79-11A0Y-020	
6	SCREW	35-41130-6RA	
7	SPRING FOR K/B LOCK KNOB	38-00R26-010	
8	K/B LOCK KNOB	42-85082-030	
9	K/B LOCK BRACKET	33-66002-020	
10	POWER KNOB	42-11A84-010	
11	SCREW	35-06125-6RA	
12	SCREW	35-01120-4RA	
13	HINGE(R) ASS'Y	79-11A0Y-010	
14	IR COVER	42-11AI2-011	
15	TOP CASE	39-11A12-01C	
16	MIC RUBBER	47-91023-010	
17	MIC,CABLE	28-H7B02-191	
18	SCREW	35-41125-4RA	
19	GLIDE POINT KNOB (R)	42-11A82-010	
20	GLIDE POINT KNOB (L)	42-11A82-020	
21	3.5" FDD	85-23211-567-C	
22	GLIDE POINT TP-3 LOGTECH	87-62070-081	
23	GLIDE PAD HOLDER	33-85002-010	
24	SWITCH BOARD	77-11A0S-D01	
25	FPC CABLE	27-9350C-B50	PUCKA
26	FFC CABLE	27-9350C-850	PUCKA
27	FDD CASE	33-11A0J-040	
28	SCREW	35-B3126-3RA	
29	FFC CABLE	27-9350C-171	PUCKA
30	MYLAR FOR FDD	40-11A5J-010	
31	SCREW	35-06120-6RA	
32	EMI SPONGE(2) FOR K/B	47-35097-020	
33	EMI SPONGE FOR K/B	47-11A97-010	

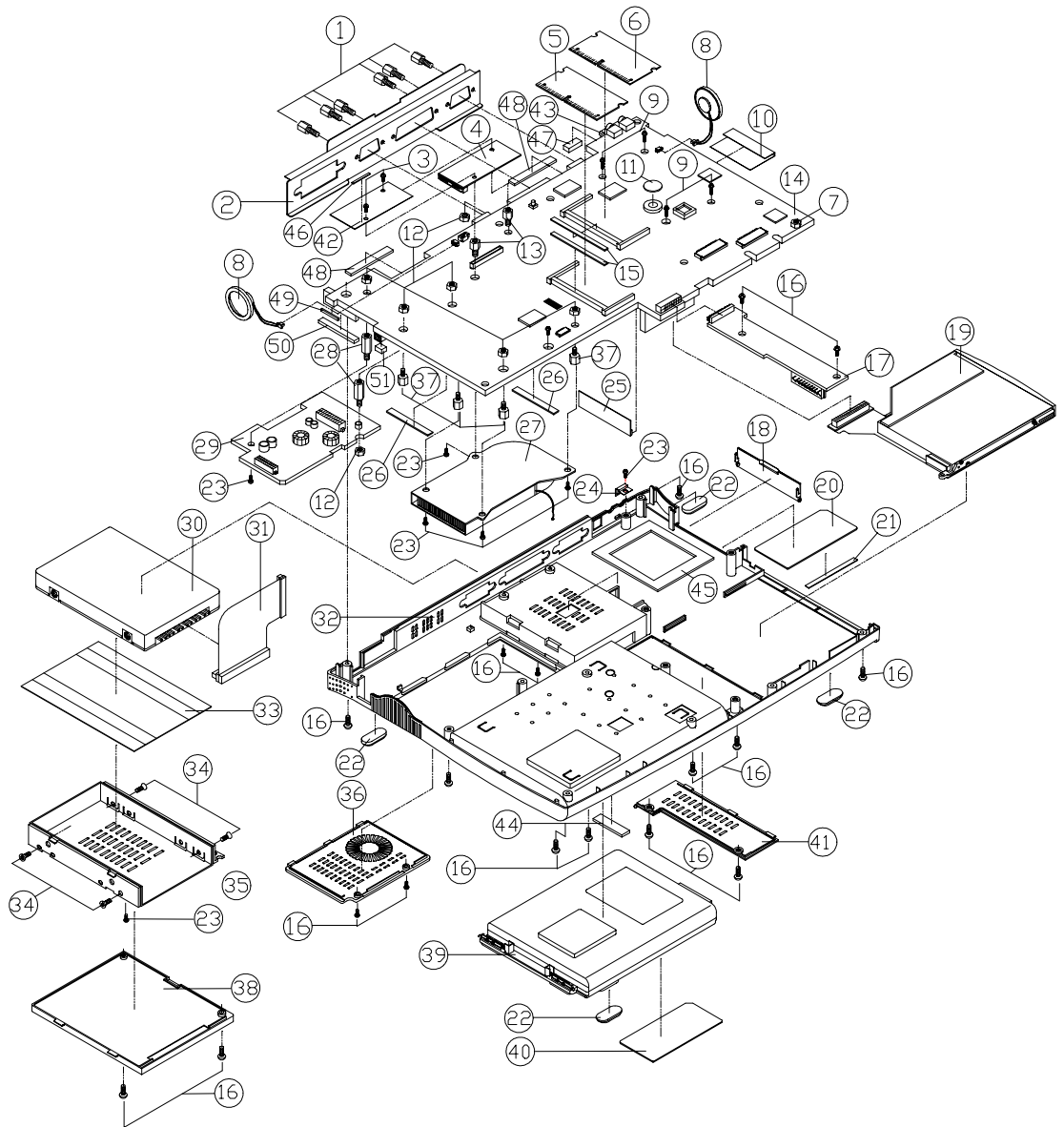

ITEM	PART NAME	PART NO	REMARK
1	HEX STUD	34-07009-011	
2	REAR BRACKET	33-11A0Q-010	
3	SCREW	35-41120-3RA	
4	DATA BOARD	77-11AFL-D01	
4	DATA BOARD	77-11ACL-D01	SAM/LG/HYUNDAZ
4	SVGA CARD	77-11ACL-D00-B	HOSIDEN
4	SVGA CARD	77-11ACL-D00-C	SANYO/KYOCERA
5	EDO RAM CARD 8M 3.3V	77-7202T-270	
5	EDO RAM CARD 16M 3.3V	77-7202T-470	
5	EDO RAM CARD 32M 3.3V	77-7207T-870	
5	EDO RAM CARD 64M 3.3V	77-7207T-A70	
6	SDRAM CARD 8M	77-7202U-273	
6	SDRAM CARD 16M	77-7202U-473	
6	SDRAM CARD 64M	77-3508U-A70	
7	HEX STUD	34-11A0S-010	
8	SPK+CON+RUBBER	23-C2605-A5E	
9	SCREW	35-41120-15A	
10	CARD BUS MYLAR	40-11M5P-011	
11	MYLAR FOR BATTERY	40-8505M-010	
12	NUT SN M2.5	36-05111-250	
13	HEX STUD	34-62M0S-02A	
14	MAIN BOARD	77-11A00-D01	
15	MYLAR FOR DIMM	40-8505S-010	
16	SCREW	35-06125-6RA	
17	CHARGER BOARD	77-11A0E-D00	
18	CARD BUS COVER	42-11A7P-011	
19	CD-ROM ASS'Y 1100	79-11A2Z-010	
20	FCC DDC LABEL	45-11A03-030	Reference Ass'y dwg (99-11A05-050)
21	EMI SPONGE FOR DC	47-11A9S-040	
22	BOTTOM CASE RUBBER PAD	47-35023-010	
23	SCREW	35-41125-4RA	
24	KEY LOCK BRACKET	33-35003-020	
25	MYLAR FOR CB-CONN.	40-11A5P-010	
26	MYLAR FOR M/B CPU	40-11A5S-020	
27	HEAT SINK ASS'Y	31-11A0N-010	
28	HEX STUD	34-11A0S-020	
29	CPU POWER BOARD	77-11AA5-D00-1	
30	HDD	42-8507Q-001	
31	FPC CABLE	28-79R44-B9E	PUCKA
32	BOTTOM CASE	39-11A13-01C	
33	MYLAR FOR HDD	40-6205I-010	
34	SCREW	35-B6130-4RA	
35	HDD BRACKET	33-11A0I-010	
36	CPU COVER+SHIELDING	42-11A73-011	
37	HEX STUD	34-8500S-030	
38	HDD COVER	42-11A7I-011	
39	BATTERY ASS'Y NI-MH	87-11A80-322A	SMP
39	BATTERY ASS'Y NI-MH	87-11A80-341A	GLW
39	BATTERY ASS'Y LI-ION	87-11A80-447A	GLW
39	BATTERY ASS'Y NI-MH	87-11A8S-341A	GLW
39	BATTERY ASS'Y LI-ION	87-11A8S-447A	GLW
39	BATTERY ASS'Y NI-MH	87-11A8S-321	SMP
39	BATTERY ASS'Y LI-ION	87-11A80-427	SMP
39	BATTERY ASS'Y LI-ION	87-11A8S-427	SMP
40	LABEL FOR BATTERY	45-11A0M-010	LI-ION
40	LABEL FOR BATTERY	45-11ASM-010	NI-MH
41	CD-ROM COVER	42-11A7Z-011	
42	MYLAR FOR DATA/B	40-11A5S-010	
43	EMI SHIELDING SPRING FOR PHONE JACK	38-11A12-010	
44	SPONGE FOR BOTTOM	47-11A93-010	
45	MYLAR FOR BOTTOM	40-11A53-010	
46	EMI SPONGE FOR DATA/B	47-11A9S-010	
47	GASKET FOR PS2	47-85093-30	
48	EMI SPONGE FOR REAR BRK	47-11A93-020	
49	EMI SPONGE FOR USB<2>	47-11A9S-030	
50	EMI SPONGE FOR USB<1>	47-11A9S-020	

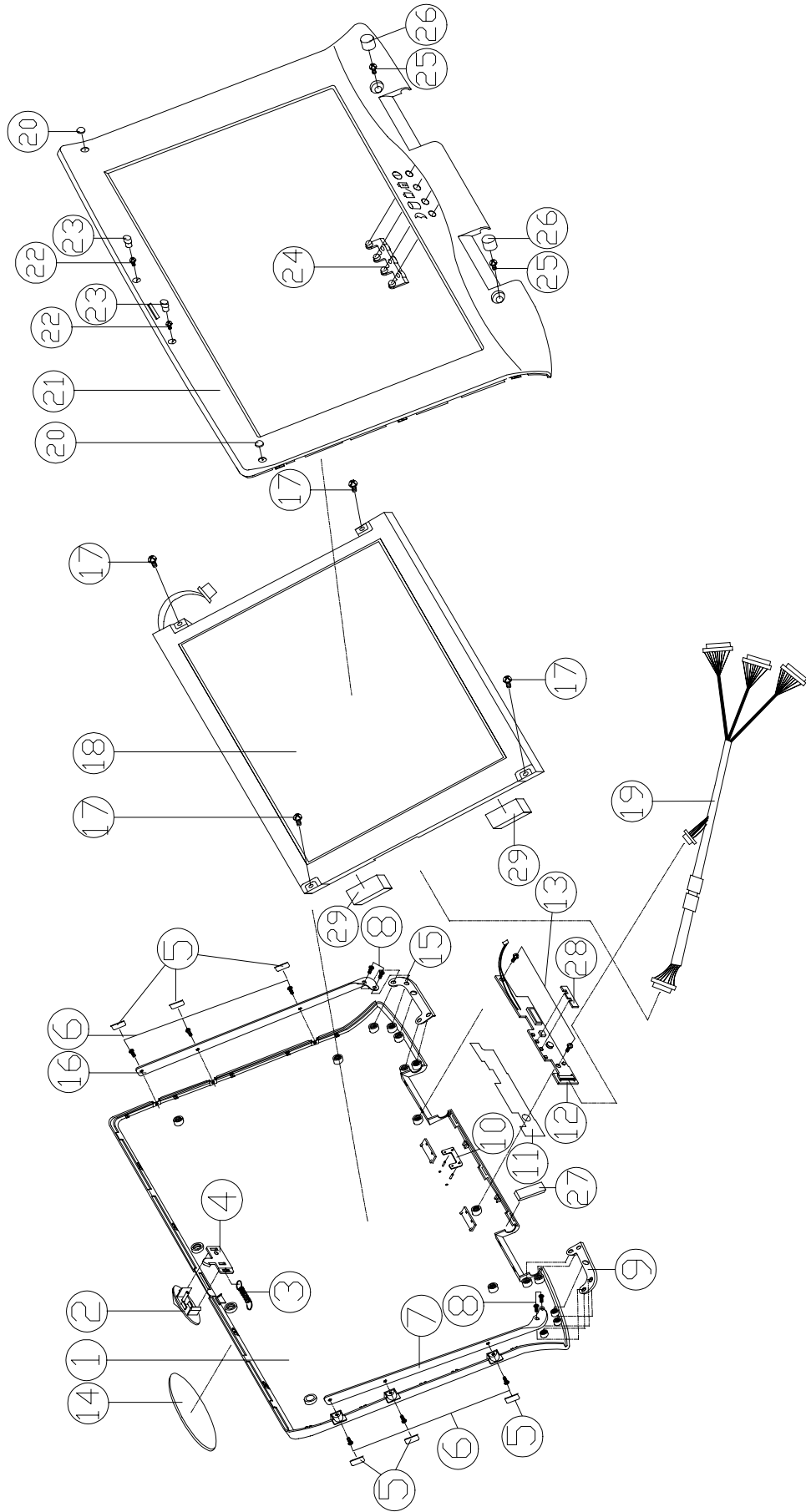

ITEM	PART NAME	PART NO	REMARK
1	DISPLAY BACK PANEL(12.1")	39-11B01-02B	KYOCERA
1	DISPLAY BACK PANEL(12.1")	39-11A01-72B	HOSIDEN
1	DISPLAY BACK PANEL(12.1")	39-11A01-12A	SAMSUNG
1	DISPLAY BACK PANEL(12.1")	39-11A01-32A	HYUNDAI
2	HOOK KNOB	42-11A81-010	
3	SPRING FOR HOOK	38-10R35-020	
4	DISPLAY HOOK	42-11AA1-010	
5	MYLAR FOR DISPLAY	40-11A51-010	
6	SCREW	35-B4125-4RA	
7	LCD BRACKET(L) FOR 12.1"	33-11A01-040	
8	SCREW	35-B6130-4RA	
9	BOSS ENHANCE BRACKET(L)	33-11A01-020	
10	LED LENS FOR BACK PANEL	42-11A01-020	
11	MYLAR FOR INVERTER	40-11A51-020	
12	INVERTER MODULE	76-110TR-D10	SAM/LG/HY/KY/SY
13	SCREW	35-41120-3RA	
14	DISPLAY BACK COVER LABEL	45-11A01-010	
15	BOSS ENHANCE BRACKET(R)	33-11A01-010	
16	LCD BRACKET(R) FOR 12.1"	33-11A01-030	
17	SCREW	35-41130-6RA	
18	LCD (12.1")	50-F5808-64K	KYOCERA
18	LCD (12.1")	50-F5708-64S	SAMSUNG
18	LCD (12.1")	50-F5708-63Y	HYUNDAI
18	LCD (12.1")	50-F5778-64H-1	HOSIDEN
19	CABLE	28-77B56-U90	HUA LI
19	CABLE	28-77B56-351	HUA LI
19	CABLE	28-77B56-X70	HUA LI
20	DISPLAY RUBBER PAD (UP)	47-11A21-010	
21	DISPLAY FRONT PANEL(12.1")	39-11A01-01B	
22	SCREW	35-01120-4R0	
23	DISPLAY RUBBER PAD (MIDDLE)	47-11A21-020	
24	LED LENS FOR FRONT PANEL	42-11A01-010	
25	SCREW	35-84130-6RA	
26	DISPLAY RUBBER PAD (LOWER)	47-85021-010	
27	EMI SPONGE	47-35091-010	
28	SPONGE FOR INVERTER LED	47-11A91-020	
29	GLIDE POINT SPONGE	47-62092-020	

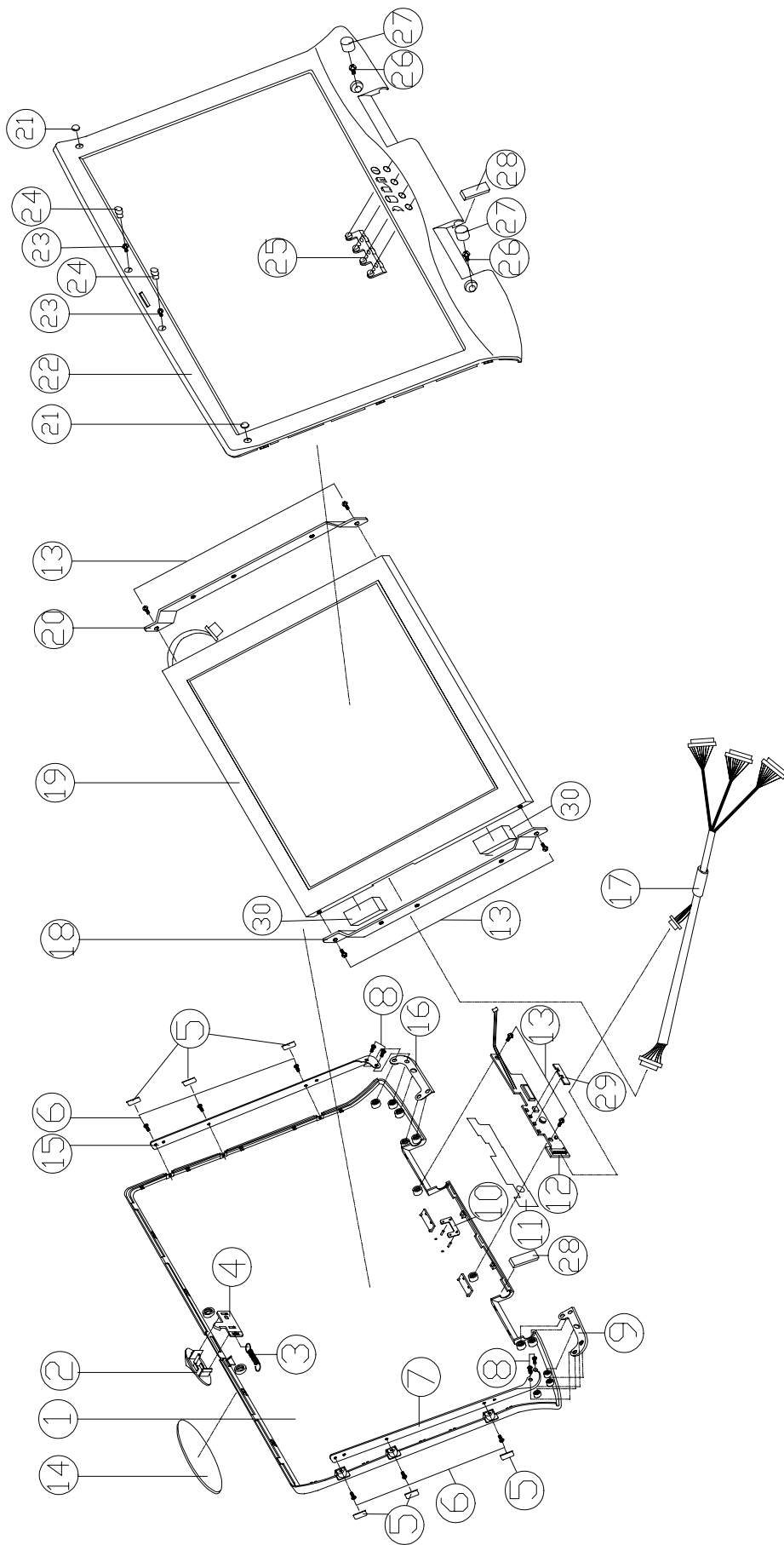

ITEM	PART NAME	PART NO	REMARK
1	DISPLAY BACK PANEL<13.3">	39-11A01-42A	SAMSUNG
1	DISPLAY BACK PANEL<13.3">	39-11A01-52A	LG
1	DISPLAY BACK PANEL<13.3">	39-11A01-62A	HYUNDAI
2	HOOK KNOB	42-11A81-010	
3	SPRING FOR HOOK	38-10R35-010	
4	DISPLAY HOOK	42-11AA1-010	
5	MYLAR FOR DISPLAY	40-11A51-010	
6	SCREW	35-B4125-4RA	
7	LCD BRACKET<L> FOR 13.3"	33-11A01-320	LG/HY
8	SCREW	35-B6130-4RA	
9	BOSS ENHANCE BRACKET<L>	33-11A01-020	
10	LED LENS FOR BACK PANEL	42-11A01-020	
11	MYLAR FOR INVERTER	40-11A51-020	
12	INVERTER MODULE	76-110TR-D10	SAM/LG/HY/HDS
13	SCREW	35-41120-3RA	
14	DISPLAY BACK COVER LABEL	45-11A01-010	
15	LCD BRACKET<R> FOR 13.3"	33-11A01-310	LG/HY
16	BOSS ENHANCE BRACKET<R>	33-11A01-010	
17	CABLE	28-77B35-020	HUA LI
17	CABLE	28-77B35-T90	HUA LI
17	CABLE	28-77B35-S50	HUA LI
17	CABLE	28-77B35-T50	HUA LI
18	LCD BRACKET<L>	33-11A01-220	LG
18	LCD BRACKET<L>	33-11A01-320	HYUNDAI
19	LCD	50-G6708-63Y	HYUNDAI
19	LCD	50-G6708-65S	SAMSUNG
19	LCD	50-G6787-63L	LG
20	LCD BRACKET<R>	33-11A01-310	HYUNDAI
20	LCD BRACKET<R>	33-11A01-210	LG
21	DISPLAY RUBBER PAD <UP>	47-11A21-010	
22	DISPLAY FRONT PANEL<13.3">	39-11A01-21B	
23	SCREW	35-01120-4R0	
24	DISPLAY RUBBER PAD <MIDDLE>	47-11A21-020	
25	LED LENS FOR FRONT PANEL	42-11A01-010	
26	SCREW	35-84130-6RA	
27	DISPLAY RUBBER PAD <LOWER>	47-85021-010	
28	EMI SPONGE	47-35091-010	
29	SPONGE FOR INVERTER LED	47-62092-020	
30	GLIDE POINT SPONGE	47-11A91-020	

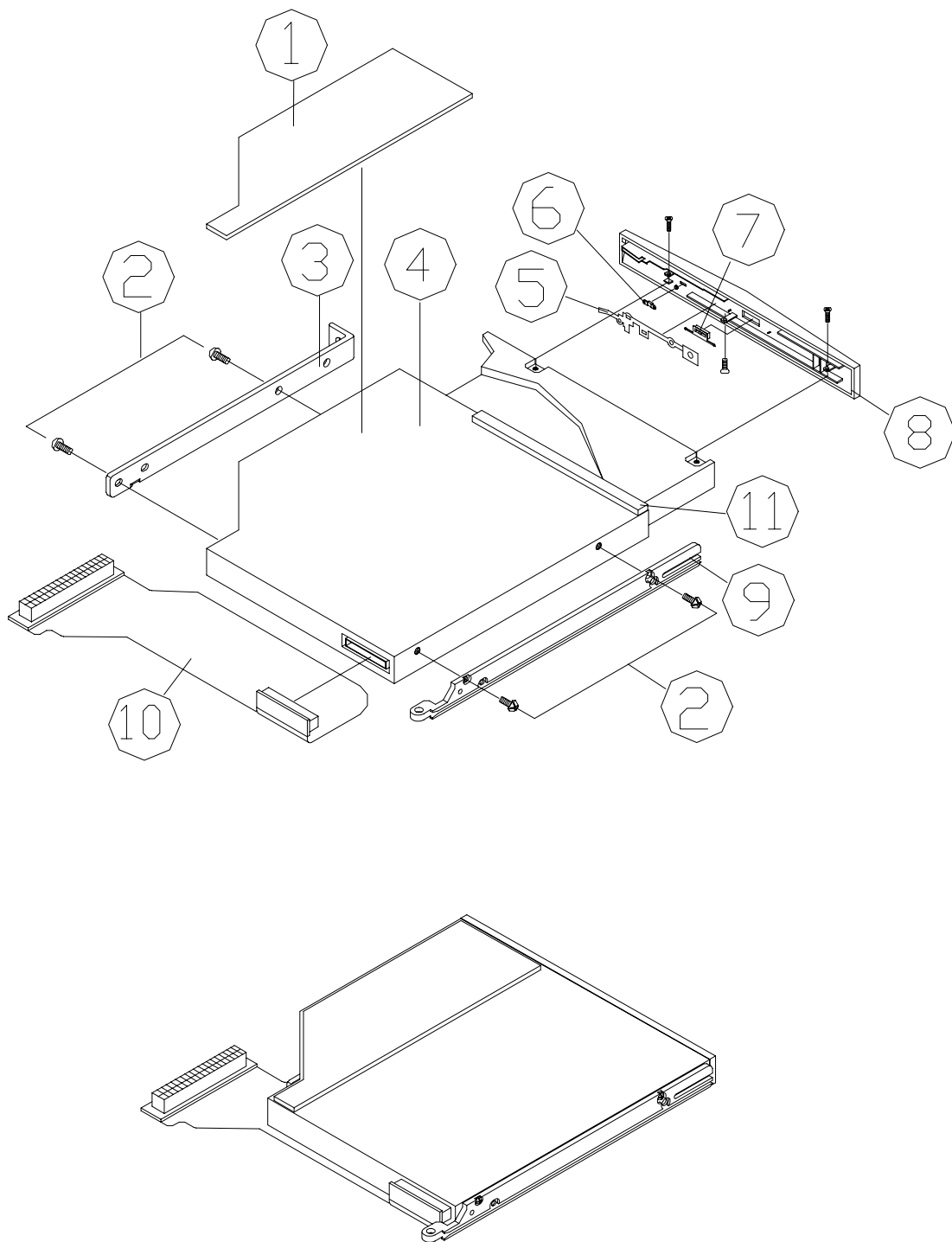

CD-ROM 組合圖

ITEM	PART NAME	PART NO	REMARK
1	MYLAR FOR CD-ROM	40-11A5Z-010	
2	SCREW	35-46120-3RA	
3	CD-ROM GUIDE RAIL(R)	42-11A7Z-040	
4	CD-ROM 24X	87-62010-054	TEAC
5	SPRING PLATE	38-62012-020	TEAC
6	CD-ROM LENS	42-52P7Z-110	TEAC
7	CD-ROM EJECT BUTTON	42-11A7Z-030	TEAC
8	CD-ROM PANEL	42-11A7Z-020	TEAC
9	CD-ROM GUIDE RAIL(L)	42-11A7Z-050	
10	FPC CABLE	28-79R50-A60	
11	SHIELD SPONGE (A) TOP CASE TO K/B	47-72092-030	

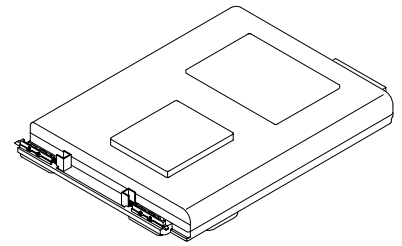
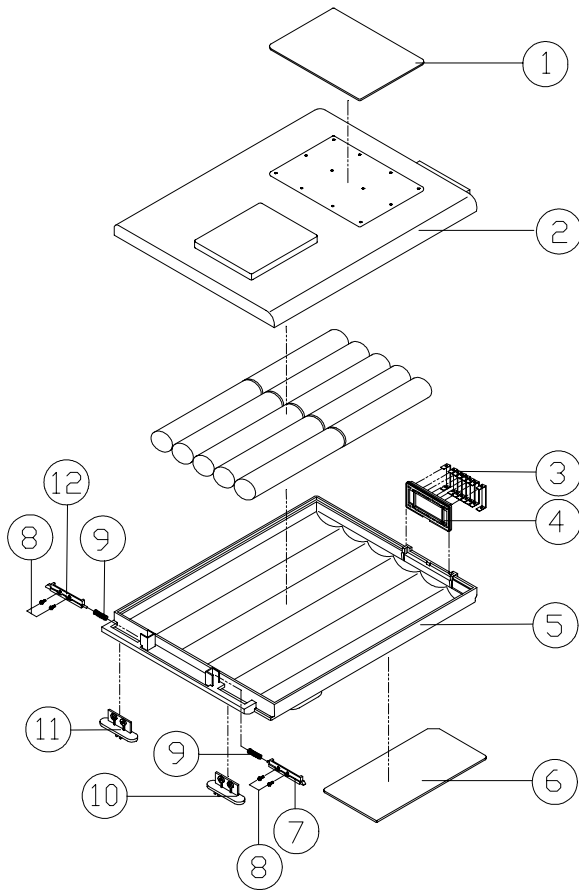

BATTERY 組合圖

ITEM	PART NAME	PART NO	REMARK
1	MYLAR FOR LI-ION	40-3505M-010	LI-ION
2	BATT. TOP CASE	42-11A3M-011	
3	BATT. CONTACT PLATE	38-11A20-010	
4	BATT. HOLDER	42-11A3M-030	
5	BATT. BOTTOM CASE	42-11A3M-021	
6	BATTERY LABEL (1001XX)	45-11A0M-010	LI-ION
6	BATTERY LABEL (1002XX)	45-11ASM-010	NI-MH
7	BATTERY LOCK(DOWN)	42-11A8M-021	
8	SCREW	35-41120-3RA	
9	SPRING FOR HDD LOCK KNOB	38-00R26-010	
10	BATTERY LOCK KNOB(DOWN)	42-11A8M-040	
11	BATTERY LOCK KNOB(UP)	42-11A8M-030	
12	BATTERY LOCK(UP)	42-11A8M-010	