

PT-6SBT
PENTIUM II
AT MAINBOARD

USER'S MANUAL

SiS5600

AT

PENTIUM II MAINBOARD

USER'S MANUAL

TABLE OF CONTENTS

Chapter & Section	Page
1. INTRODUCTION	1-1
1.1 OVERVIEW	1-1
1.2 MAINBOARD LAYOUT	1-2
1.3 SPECIFICATIONS	1-3
2. INSTALLATION.....	2-1
2.1 UNPACKING	2-1
2.2 AMAZING WAYS TO POWER ON THE PC SYSTEM.....	2-2
2.3 POWER OFF THE PC SYSTEM.....	2-4
3. HARDWARE SETUP	3-1
3.1 INSTALLING THE DRAM MODULES.....	3-1
3.2 CONNECTORS.....	3-2
3.3 JUMPERS	3-15
4. AWARD BIOS SETUP	4-21
4.1 GETTING STARTED	4-21
4.2 MAIN MENU.....	4-22
4.3 CONTROL KEYS.....	4-22
4.4 STANDARD CMOS SETUP.....	4-23
4.5 BIOS FEATURES SETUP	4-24
4.6 CHIPSET FEATURES SETUP.....	4-27
4.7 POWER MANAGEMENT SETUP.....	4-32
4.8 INTEGRATED PERIPHERALS	4-38
4.9 PNP/PCI CONFIGURATION	4-41
4.10 LOAD SETUP DEFAULTS	4-44
4.11 SUPERVISOR PASSWORD / USER PASSWORD	4-45
4.12 IDE HDD AUTO DETECTION.....	4-46
4.13 SAVE & EXIT SETUP.....	4-47
4.14 EXIT WITHOUT SAVING.....	4-48

SOMETHING IMPORTANT !

☆ **TRADEMARKS**

All trademarks used in this manual are the property of their respective owners.

☆ **LOAD SETUP DEFAULTS**

“LOAD SETUP DEFAULTS” is the function which will have the BIOS default settings loaded into the CMOS memory, these default settings are the best-case values that should optimize system performance and increase system stability .This function will be necessitated when you receive this mainboard, or when the system CMOS data is corrupted. Please refer to the Section 4-10 for the details.

☆ **DISCHARGE CMOS DATA**

Whenever you want to discharge the CMOS data or open the system chassis, Make sure to disconnect the AC power first because there is always the 5V standby voltage connected to this mainboard when using an ATX switching power supply. Without disconnecting the AC power connector from the PC system, the mainboard may be damaged by any improper action . Please refer to the Section 3-3 for details.

☆ **WAKE ON LAN**

In order to support the Wake On LAN feature, the system requires a ATX type SPS (switching power supply) and it must be able to provide at least 700 mA of driving capability on the “5V standby” voltage. Please refer to the Section 3-3 for details.

☆ **WARNING !**

The "Static Electricity" may cause damage to the components on the mainboard, In order to avoid the damage to the mainboard accidentally, please discharge all static electricity from your body before touching this mainboard.

☆ **NOTICE**

The information contained in this manual is subject to change without notice.

IMPORTANT : In case that you make a wrong BIOS setup and you can not power on the PC system, you may press and hold the "INSERT" key and then press the PW button to turn the system power on. When you are using such way to power on you PC system, the system BIOS will force the PC system running at the slower speed and then you may trigger the BIOS setup program and select the proper parameters for the mainboard. (such feature is valid for both AT and ATX power)

1. INTRODUCTION

1.1 OVERVIEW

This mainboard is the AT form-factor with A.G.P. (Accelerated Graphics Port) and PCI Local Bus on board, designed based on the SiS5600, SiS5595 system chipset. It is a high performance Pentium™ II personal computer mainboard with 100MHz ultra high Front Side Bus (FSB) frequency. It is designed for the high performance Pentium™ II or Celeron™ processor 233 MHz, 266 MHz, 300 MHz, 333MHz, 366MHz, 400MHz, 450MHz and up to 500MHz. (The clock ratio selectable can be up to 8X on the board.)

The jumper-free feature is designed on the board and you don't have to make any jumper or switch setting when installing the CPU. For example, when you are installing the CPU onto the mainboard, the system board will detect the CPU type and decide the proper Voltage. As for the CPU frequency, you can choose to have the system board detect the CPU type and decide the frequency for you, or you may use the BIOS setup program to select the CPU clock by yourself.

Two channels "PIO" and "Ultra DMA/33 Bus Master" mode PCI IDE ports, one Floppy Disk control port, two high speed Serial ports (UARTs) and one multi-mode Parallel port and supports PS/2™ mouse, IR and USB ports are built on the board..

The Pentium™ II and Celeron™ Processor are the 64-bit processors with RISC technology, which offer several key features such as built-in 128/256KB/512KB L2 cache (some Celeron does not have L2 cache), 12-stage super-pipeline architecture, out of order execution etc. In order to optimize of its performances, the 32-bit Operating System (such as Windows® NT and OS/2™) and 32-bit applications are recommended.

The Accelerated Graphics Port (A.G.P.) on the mainboard is designed for AGP 3D video display card. Unlike PCI-based display cards, the AGP technology provides lightning data throughput to fully facilitate the 3-Dimensional and multimedia graphics display. The data transfer rate on AGP can be up to 133Mhz and which is much faster than the traditional 33MHz PCI VGA card.

1.2 MAINBOARD LAYOUT

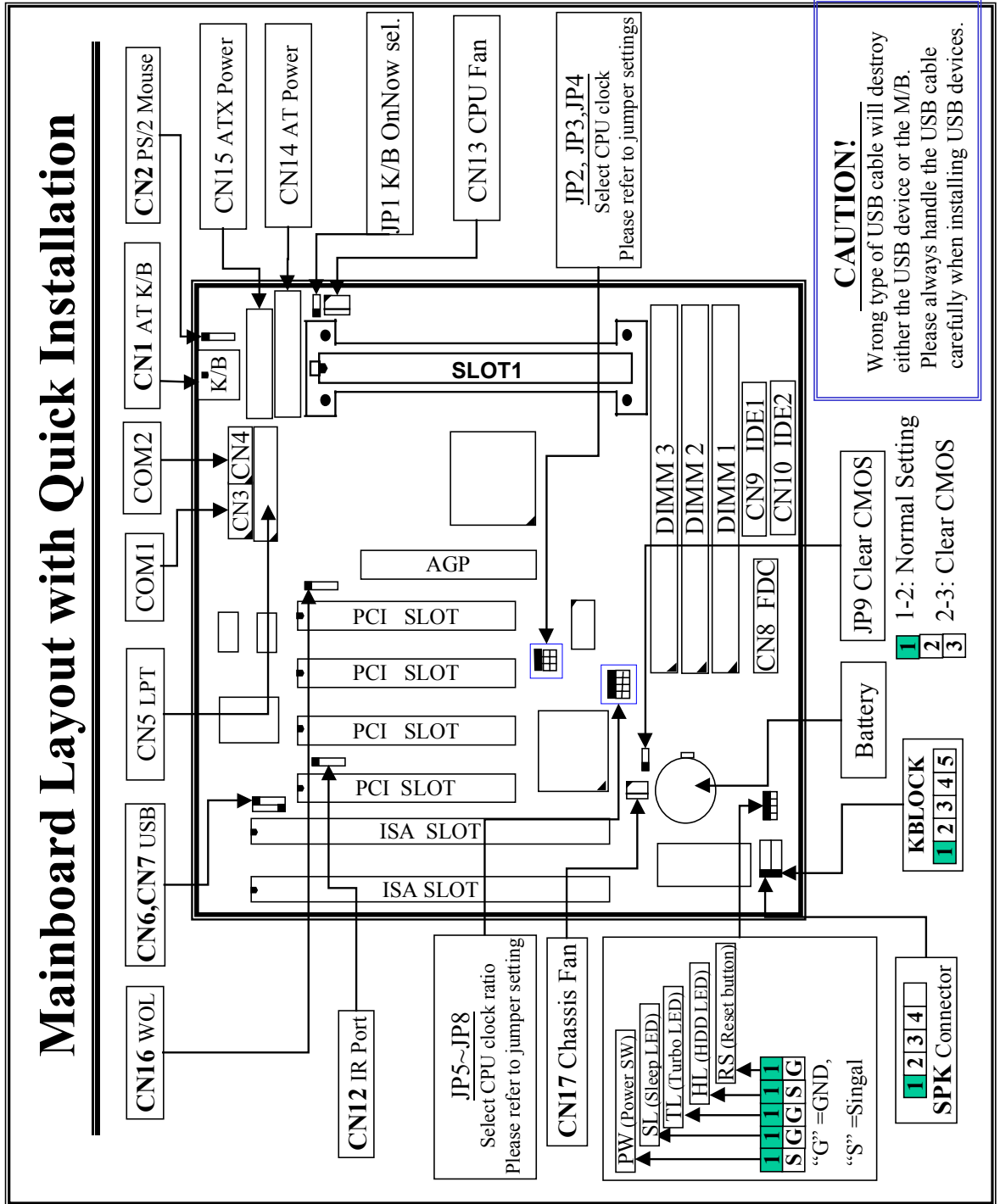

1.3 SPECIFICATION

⊙ CPU

Intel Pentium™ II processor and Celeron™ processor.

1. When the FSB clock is 66 MHz, it supports 233 MHz up to 533 MHz CPUs.
2. When the FSB clock is 100 MHz, it supports 350 MHz up to 500 MHz CPUs.

⊙ CPU VCC

Switching Voltage Regulator onboard, supports +1.30V DC ~ +3.5V DC Vcore.

Note : The CPU Core Voltage will be Detected and adjusted automatically by the mainboard, so there is no jumper setting required to select the CPU voltage.

⊙ WORD SIZE

Data Path : 8-bit, 16-bit, 32-bit, 64-bit

Address Path : 32-bit

⊙ PC SYSTEM CHIPSET

SiS5600 and SiS5595 system chipset.

⊙ SUPER I/O CHIPSET

FDC37C669

⊙ FRONT SIDE BUS FREQUENCY

66.6, 75, 83.3,,95, 100, 112, 124, 133MHz (Selected by system BIOS).

⊙ MEMORY

DRAM : Three 168 pin DIMM sockets onboard, support 3.3V SDRAM DIMM modules. Max. memory size : 768MB

CACHE: 256KB or 512KB L2 Cache memory built-in Pentium™ II processor.

0KB or 128KB L2 Cache memory in Celeron™ processor.

⊙ BIOS

AWARD System BIOS.

(2MB Flash ROM, supports Plug & Play, ACPI, DMI and Green functions).

⊙ EXPANSION SLOTS

AGP Slots : 32-bit x 1 (Supports 1x or 2x AGP graphics cards)

PCI Slots : 32-bit x 4 (All Master/Slave, PCI 2.1 Compliant)

ISA Slots : 16-bit x 2 (One of the slot is PCI/ISA shared)

⊙ POWER CONNECTOR

AT and ATX power connectors are both designed on the mainboard.

⊙ WOL PORTS

One WOL connector supports Wake-On-LAN

⊙ USB PORTS

Two Universal Serial Bus (USB) ports.

⊙ IDE PORTS

Two channels of Ultra DMA/33 Bus Master IDE ports, which will support up to 4 IDE devices like IDE hard disk, ATAPI CD-ROM etc. The IDE ports can be programmed to support PIO Mode 4, DMA mode 2 and Ultra DMA/33.

⊙ SUPER I/O PORTS

1. Supports PS/2 Mouse connector, PS/2 Keyboard connector (optional) and AT Keyboard connector.
2. Two high speed NS16C550 compatible serial ports (UARTs).
3. One SPP/EPP/ECP parallel port.
4. One Floppy Disk Control port.

⊙ IR PORT

One HPSIR and ASKIR or Fast IR (optional) compatible IR port.

⊙ HARDWARE MONITORING

1. Monitor the system voltages, CPU temperature, and two cooling fan speeds.
2. Supports LDCM (optional).

⊙ ACPI (*This feature is valid only when ATX power supply is connected*)

Advanced Configuration and Power Interface (ACPI) function is strongly recommended by PC'98 because it will let you have many additional features and that will make your PC system becomes very friendly and convenient. Followings are the ACPI features designed on the board:

1. Power on the system by panel-switch
2. Power on the system by RTC alarm
3. Power on the system by modem Ring-in signal
4. Power on the system by LAN signal.(Wake On LAN)
5. Power on the system by Keyboard (*Optional*).
6. Resumed by Modem ring-in, RTC alarm, etc..
7. Supports Full-On/Doze/Standby/Suspend operating modes.
8. Power off (soft-off) by OS (active with ATX SPS only) or Panel-switch.

◎ DIMENSION

4-layers PCB, 220mm x 240mm (Baby-AT Form-Factor)..

◎ ENVIRONMENT LIMIT

1. Operating Temperature : 10□ to 40□. (50□ to 104□)
2. Required Airflow : 50 linear feet per minute across CPU.
3. Storage Temperature : - 40□ to 70□. (- 40□ to 158□)
4. Humidity : 0 to 90% non-condensing.
5. Altitude : 0 to 10,000 feet.

2. INSTALLATION

2.1 UNPACKING

The mainboard contains the following components in the package. Please inspect the following contents and confirm that everything is there in the package. If anything is missing or damaged, call your supplier for instructions before proceeding.

- This mainboard.
- One USER'S MANUAL.
- One Cable set for peripheral devices.
- One Pentium™ II Processor Retention Mechanism (CPU Holder).
- One CD diskette for device drivers and utility programs.

This mainboard contains electrostatic sensitive components and it can be easily damaged by static electricity. So please leave it sealed in the original packing until when installing.

A grounded anti-static mat is recommended when unpacking and installation. Please also attached an anti static wristband to your wrist and have it grounded to the same point as the anti-static mat.

After the opening of the mainboard carton, please observe the mainboard carefully to make sure there is no shipping and handling damage before you can start to install the PC system.

2.2 AMAZING WAYS TO POWER ON THE PC SYSTEM

Basically, you can connect either AT or ATX power supply to this mainboard. When the ATX power supply is connected, there are many ways to power on the system. Please read the following description for the details.

□ POWER BUTTON

The power button on the front panel is not only for power-on and power-off the PC system. It can be programmed by COMS setup program and it has different features. Please refer to Section 3-2 for the detail of function description.

□ KEYBOARD PASSWORD (*optional*)

This mainboard allows you to enter your personal password and you can use it to power on your system. When the system power is off, this mainboard has the stand-by 5V voltage active and it will keep scanning the keyboard status waiting for the correct password input to turn on the system power. (you will see the Keyboard LED lights when system power is off, it is because the standby 5V is still active.)

When the "Password" is "enabled" in the system BIOS, you will have to reboot the PC system to activate the setting, when you see the POST (Power On Self Test) is completed, the setting is changed and stored in the CMOS memory. Having finished the procedure, you may turn the power off and then you can use the keyboard to power-on the PC system afterward.

□ RTC ALARM

PC system can be waked up by the RTC setting in the CMOS. You can set the alarming date and time in the RTC memory, when RTC alarms, the PC system will be triggered and wakes up automatically.

Enable the "Power Up by Alarm" selection in the BIOS setup utility, and then input the accurate date and time in its following fields. (the "Power Up by Alarm" is in the "POWER MANAGEMENT SETUP" section, please refer to Section 4-7), Having stored the RTC alarm setting, the PC system will be turned on automatically according to the date and time which is recorded in the CMOS memory.

□ MODEM RING-IN

This mainboard can be triggered by a modem ring-in signal. When you have a *external* modem installed, you can use it to power on the PC system. When there is the incoming message from the external modem, the PC system will be triggered by the ring-in signal and wake up automatically to receive the message for you.

In order to use the ring-in signal to wake up your PC system, you will have to use the *EXTERNAL MODEM* and have it connected to one of the *Serial Ports* (COM1 or COM2). When the system power is off, this mainboard will continue to detect the serial port status. When it detects the ring-in signal from the serial port, the system power will be turned on and start to receive the incoming messages automatically.

To enable the Modem Ring-In feature, you have to run the BIOS setup utility and enable the “Ring Power Up Control” option (it is in the “POWER MANAGEMENT SETUP”, please refer to Section 4-7 for the settings).

Note: This function is not available when using the internal MODEM card.

□ WAKE ON LAN (WOL)

There is a WOL connector CN16 (see Section 3-2) on the mainboard which is designed to connect to the signal from a LAN card which supports the Wake On LAN feature. When such LAN card is installed, you may use it to turn on the PC system from your remote server and monitor the PC status.

To enable this feature, you will have to use the BIOS setup utility to enable the “Ring Power Up Control” (it is located at “POWER MANAGEMENT SETUP”, please refer to Section 4-7 for the settings).

2.3 POWER OFF THE PC SYSTEM

1. When ATX power supply is connected.

There are two ways to power off the system.

- a) Shut Down by Power Button

- b) Shut Down by OS". (such as Windows® 95 and Windows® 98, you can choose the **Shut Down** from the file menu and the system will be powered off immediately).

2. When AT power supply is connected.

You **can not** use the power button (PW switch) to turn the system power off. You can only use the power switch on the power supply to power off the PC system

IMPORTANT: In case that you make a wrong BIOS setup and you can not power on the PC system, you may press and hold the "INSERT" key and then press the PW button to turn the system power on. When you are using such way to power on you PC system, the system BIOS will force the PC system running at the slower speed and then you may trigger the BIOS setup program and select the proper parameters for the mainboard. (such feature is valid for both AT and ATX power)

3. HARDWARE SETUP

Before you can start to install this mainboard, some hardware settings is required to make sure it will work perfectly with the component which you are going to install in your PC system. To configure this mainboard is a simple task, only a few jumpers, connectors, cables and sockets need to be selected and configured. Please refer to the following sections for the settings.

3.1 INSTALLING THE DRAM MODULES

This mainboard integrates a main memory controller that supports a 64-bit DRAM interface. The DRAM controller supports the following features:

1. **DRAM type: Synchronous (SDRAM) DRAM.**
2. **Memory size: 8MB to 768MB.**
3. **Memory modules supported: Single and double density 3.3V DIMMs.**

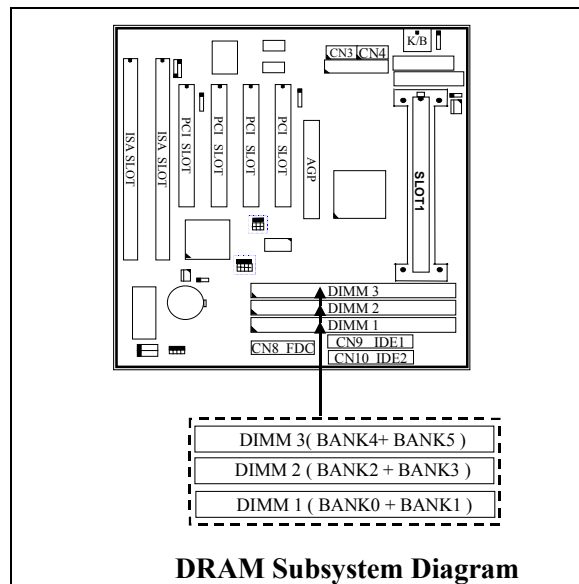

When use the SDRAM DIMM modules on the mainboard, the clock of the memory sub-system will be synchronous with the FSB clock. So please use the PC-100 compatible DIMM modules when you are using the 100MHz CPU on the mainboard.

The memory module suggested on this mainboard will be either EDO or SDRAM 3.3V modules, When you are installing memory modules on the mainboard, you don't have to start from DIMM 1 first, you can install the memory in any of the sock which is available. However, if you use this mainboard to upgrade your PC system and you want to keep your old memory modules. In case that you have more than one modules and they have different access time. In this case, please install the slower DIMM module in DIMM1 first and then install the faster ones in DIMM2 and DIMM3. Please also run the BIOS setup program and select the parameters which is comply with the slowest module installed on the mainboard.

Note: In order to increase of the system performance and steability, install memory modules starting from DIMM 1 is recommended

3.2 CONNECTORS

The connectors on mainboard will be used to connect the accessories or peripheral devices (such as power, mouse, printer,...etc.). Followings are the connectors with its description and pin assignment which is designed on the mainboard.

(A) BAT1: Battery Socket (Use the 3 Volts Lithium battery : CR2032)

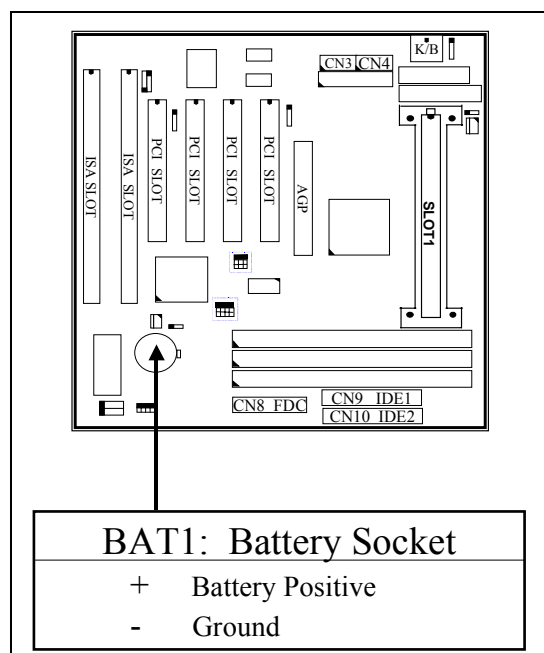

(B) CN1: Keyboard Connectors

Either the PS/2 (CN20) type or the AT (CN1) type keyboard connector can be installed here, (only one connector can be installed) The factory default is the AT type connector installed on the board. When the AT type K/B installed on the board, the PS/2 type (CN20) become invisible.

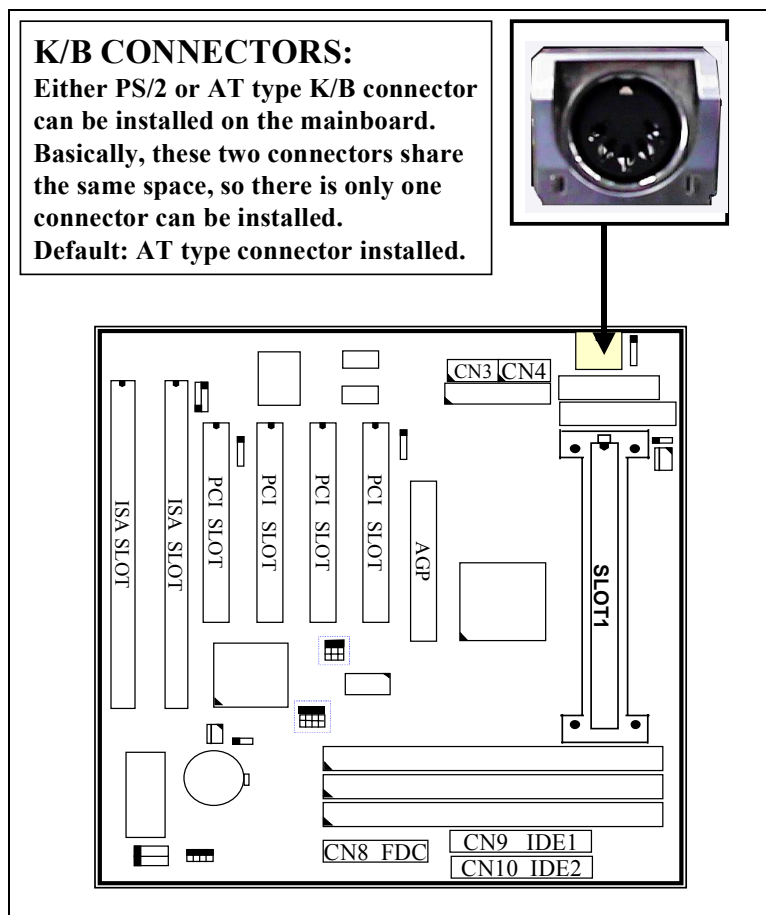
**Pin assignment of PS/2 keyboard connector: (CN20 is under CN1)**

<u>Pin #</u>	<u>Signal name</u>	<u>Pin #</u>	<u>Signal name</u>	<u>Pin #</u>	<u>Signal name</u>
1	Keyboard Data	3	Ground	5	Keyboard Clock
2	No Connection	4	+ 5V DC	6	No Connection

Pin assignment of AT keyboard connector: (CN1)

<u>Pin #</u>	<u>Signal name</u>	<u>Pin #</u>	<u>Signal name</u>	<u>Pin #</u>	<u>Signal name</u>
1	Keyboard clock	3	No connection	5	Keyboard Clock
2	Keyboard data	4	Ground	6	+ 5V DC

(C) CN2: PS/2 Mouse Connector

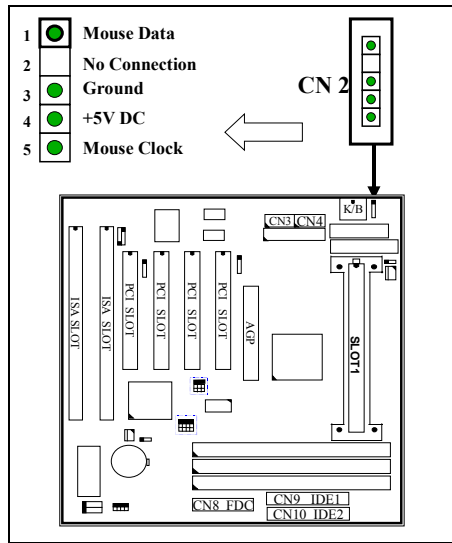

**(D) CN3: COM 1 (Serial Port 1) Connector
CN4: COM 2 (Serial Port 2) Connector**

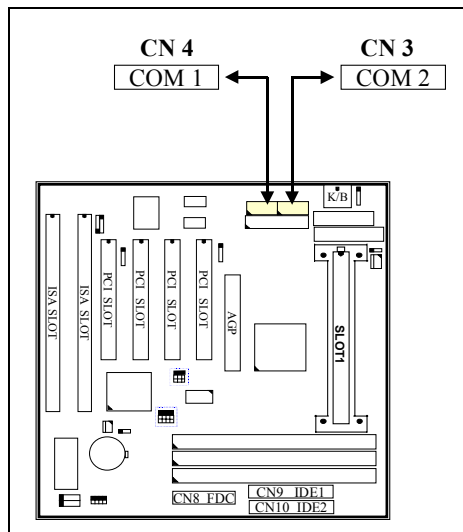

Ping assignment of serial port connector:

1	6	Pin #	Signal name
<input type="checkbox"/>	<input type="checkbox"/>	1	DCD (Data Carrier Detect)
<input type="checkbox"/>	<input type="checkbox"/>	2	RD (Received Data)
<input type="checkbox"/>	<input type="checkbox"/>	3	TD (Transmit Data)
<input type="checkbox"/>	<input type="checkbox"/>	4	DTR (Data Terminal Ready)
<input type="checkbox"/>		5	Ground

Pin #	Signal name
6	DSR (Data Set Ready)
7	RTS (Request To Send)
8	CTS (Clear To Send)
9	RI (Ring Indicator)

I/O address 3F8H/2F8H/3E8H/2E8H, IRQ3/IRQ4, selected by CMOS setup.

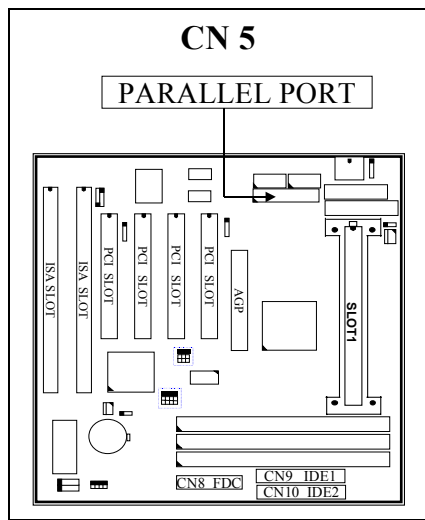
(E) CN5: Parallel Port Connector**Pin assignment of parallel port:**

1	14	Pin #	Signal name	Pin #	Signal name
<input type="checkbox"/>	<input type="checkbox"/>	1	STROBE <input type="checkbox"/>	14	AUTO FEED <input type="checkbox"/>
<input type="checkbox"/>	<input type="checkbox"/>	2	Data Bit 0	15	ERROR <input type="checkbox"/>
<input type="checkbox"/>	<input type="checkbox"/>	3	Data Bit 1	16	INIT <input type="checkbox"/>
<input type="checkbox"/>	<input type="checkbox"/>	4	Data Bit 2	17	SLCT IN <input type="checkbox"/>
<input type="checkbox"/>	<input type="checkbox"/>	5	Data Bit 3	18	Ground
<input type="checkbox"/>	<input type="checkbox"/>	6	Data Bit 4	19	Ground
<input type="checkbox"/>	<input type="checkbox"/>	7	Data Bit 5	20	Ground
<input type="checkbox"/>	<input type="checkbox"/>	8	Data Bit 6	21	Ground
<input type="checkbox"/>	<input type="checkbox"/>	9	Data Bit 7	22	Ground
<input type="checkbox"/>	<input type="checkbox"/>	10	ACK <input type="checkbox"/>	23	Ground
<input type="checkbox"/>	<input type="checkbox"/>	11	BUSY	24	Ground
<input type="checkbox"/>	<input type="checkbox"/>	12	PE	25	Ground
<input type="checkbox"/>		13	SLCT	26	N.C.
13	25				

(F) CN6: USB 1 (Universal Serial Bus) Connector

(G) CN7: USB 2 (Universal Serial Bus) Connector

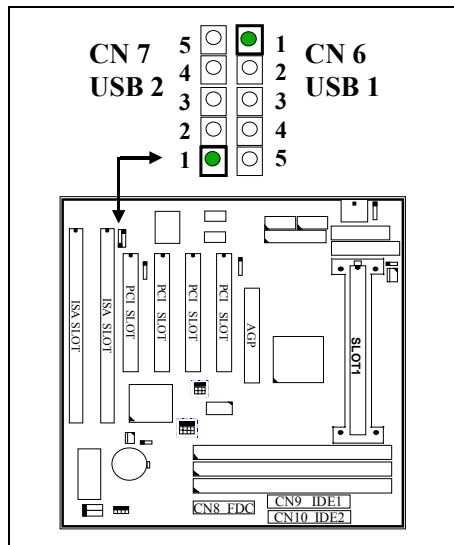

Pin assignment of USB connector:

CN 7			CN 6		
Pin #	Assignment		Pin #	Assignment	
● 5	Ground (BLACK WIRE)		● 1	+5V DC (RED WIRE)	
● 4	Ground (BLACK WIRE)		● 2	DATA- (WHITE WIRE)	
● 3	DATA+ (GREEN WIRE)		● 3	DATA+ (GREEN WIRE)	
● 2	DATA- (WHITE WIRE)		● 4	Ground (BLACK WIRE)	
● 1	+5V DC (RED WIRE)		● 5	Ground (BLACK WIRE)	

(H) CN8: Floppy Disk Control Port Connector (using IRQ6, DMA 2):

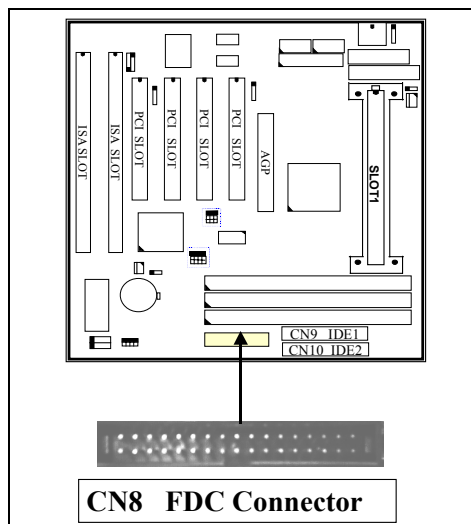

(I) CN9: IDE 1 Connectors, (Primary IDE Port: 1F0H, IRQ 14)

(J) CN10: IDE 2 Connectors, (Secondary IDE Port: 170H, IRQ 15)

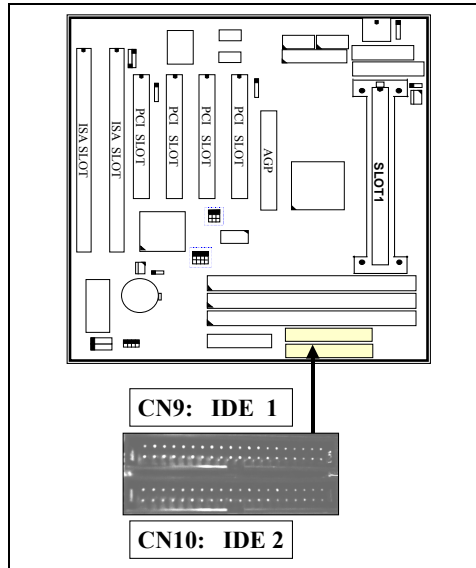

(K) CN12: IR / FIR (Infrared Rays) Connector

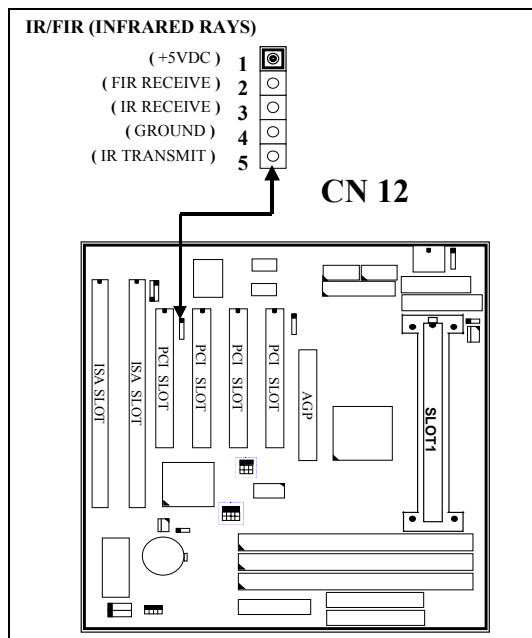

(L) CN13: CPU Cooling Fan Power Connector

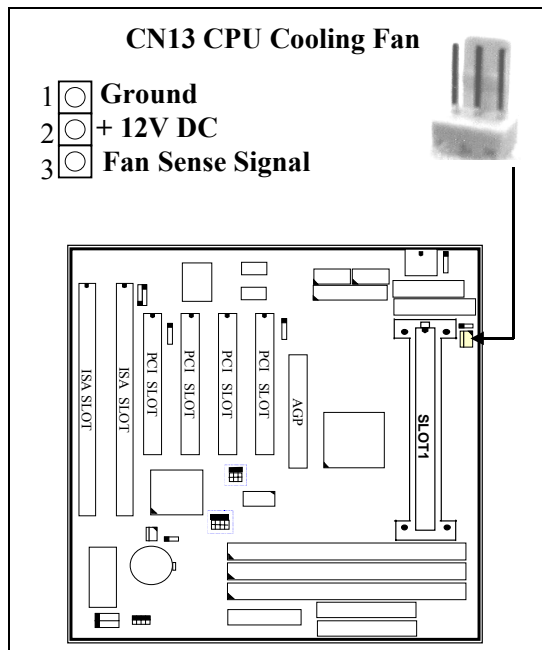

(M) CN14: AT Power Connector:

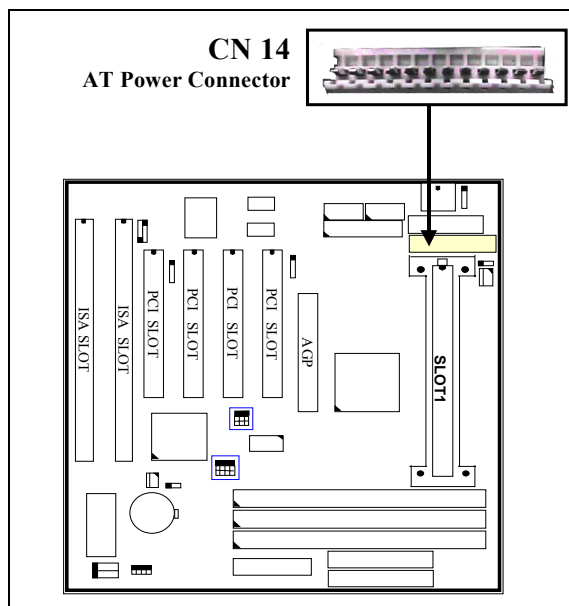

PIN ASSIGNMENT OF AT POWER CONNECTOR:

		<u>Pin #</u>	<u>Assignment</u>	
P8	1	1	Power Good	(Orange)
	2	2	+5V DC	(Red)
	3	3	+12V DC	(Yellow)
	4	4	-12V DC	(Blue)
P9	5	5	Ground	(Black)
	6	6	Ground	(Black)
	7	7	Ground	(Black)
	8	8	Ground	(Black)
	9	9	-5V DC	(White)
	10	10	+5V DC	(Red)
	11	11	+5V DC	(Red)
	12	12	+5V DC	(Red)

Note: There are two connectors from the switching power supply (P8 & P9), Wrong connection will cause permanent damage to the mainboard. Be sure to make the power connector correctly all the time. Joint the black cable and then have the connectors connected to the mainboard.

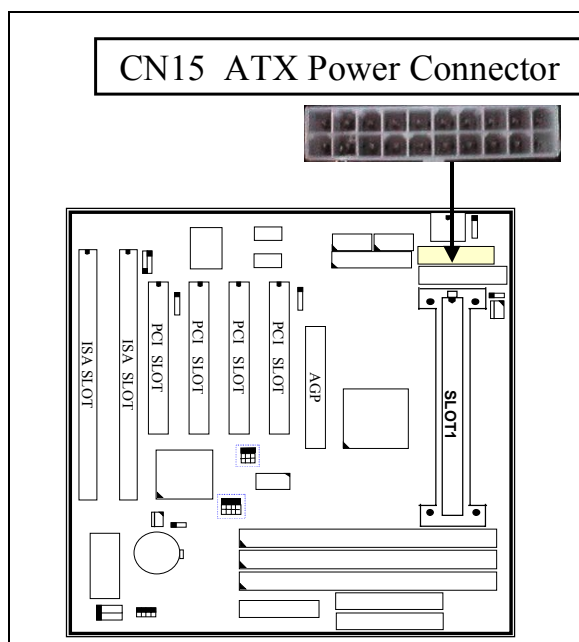
(N) CN15: ATX Power Connector:

PIN ASSIGNMENT OF ATX POWER CONNECTOR:

11	1	Pin #	Signal name	Pin #	Signal name
<input type="checkbox"/>	<input type="checkbox"/>	11	+ 3.3V DC	1	+ 3.3V DC
<input type="checkbox"/>	<input type="checkbox"/>	12	- 12V DC	2	+ 3.3V DC
<input type="checkbox"/>	<input type="checkbox"/>	13	Ground	3	Ground
<input type="checkbox"/>	<input type="checkbox"/>	14	PS-ON	4	+ 5V DC
<input type="checkbox"/>	<input type="checkbox"/>	15	Ground	5	Ground
<input type="checkbox"/>	<input type="checkbox"/>	16	Ground	6	+ 5V DC
<input type="checkbox"/>	<input type="checkbox"/>	17	Ground	7	Ground
<input type="checkbox"/>	<input type="checkbox"/>	18	- 5V DC	8	PW-OK
<input type="checkbox"/>	<input type="checkbox"/>	19	+ 5V DC	9	+ 5V SB
<input type="checkbox"/>	<input type="checkbox"/>	20	+ 5V DC	10	+ 12V DC
20	10				

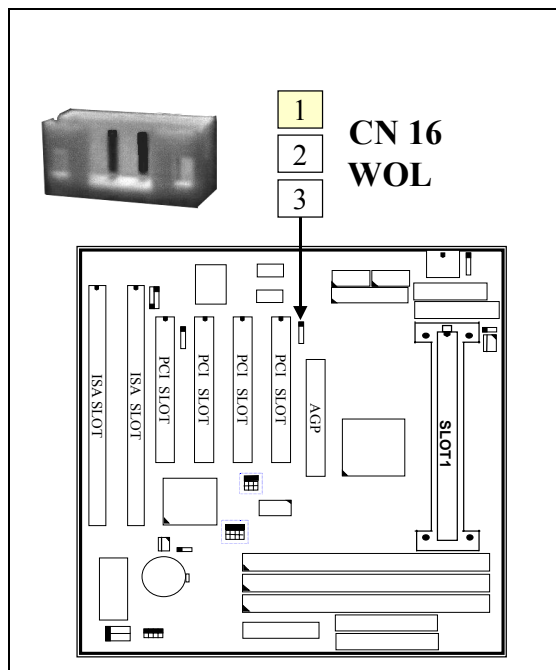
(O) CN16: WOL (Wake On LAN) Connector**Pin assignment of WOL Connector**

1	2	3	Pin #	Signal name	Pin #	Signal name	Pin #	Signal name
<input type="checkbox"/>	<input type="checkbox"/>	<input type="checkbox"/>	1	5V standby	2	Ground	3	WOL Signal

(P) CN17: Chassis Fan Power Connector (CPUFAN2)

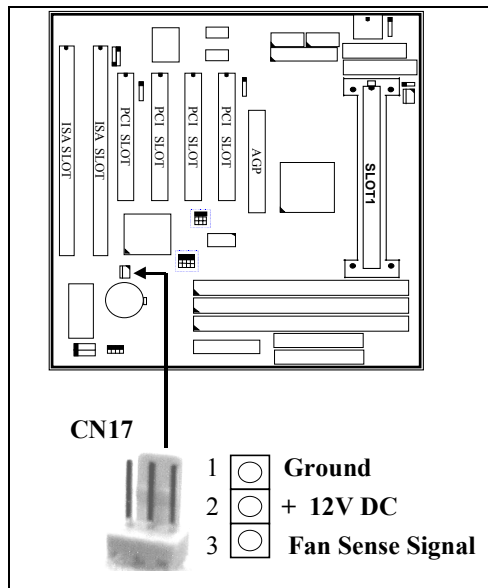

(Q) Push buttons and LED connectors

A series of connectors are designed on the board to connect the push buttons and LED indicators. Followings are the details:

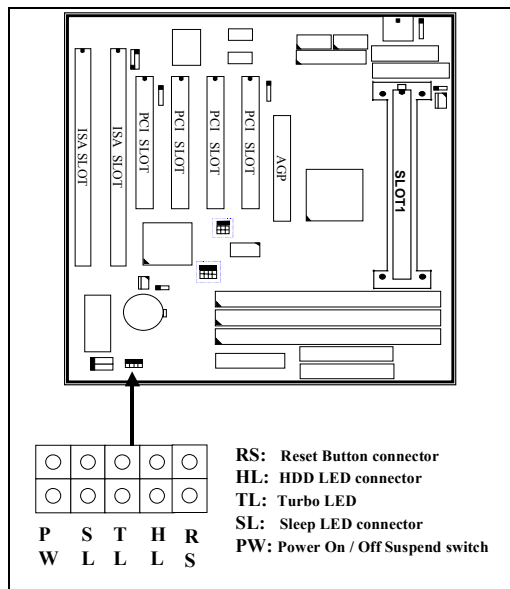

1. RS Reset Button Connector

Pin #	Signal name	Pin1&2	Function
1	Reset Control	Open	No action
2	Ground	Short	System Reset

2. HL IDE HDD LED Connector

<u>Pin #</u>	<u>Signal name</u>
1	+ 5V DC Pull-up
2	HDD Active Signal

3. TL TURBO LED Connector

<u>Pin #</u>	<u>Signal name</u>
1	+ 5V DC Pull-up
2	Ground

4. SL Sleep LED Connector (*valid only with ATX power supply*)

This LED will be lightened when the AC power is connected and the system is power off, darkened when the AC power is disconnected or the system is powered on.

<u>Pin #</u>	<u>Signal name</u>
1	Signal Pin
2	Ground

5. PW Power On / Off and External Suspend Switch Connector

5-a. When this mainboard has the ATX power supply connected, According to the setup in CMOS, the PW connector has two functions. It can be the Power Switch or Suspend Switch of your PC system.(please refer to Section- 4-7 and section 4-8 for BIOS setup)

① If the setup in CMOS is “Delay 4 Sec.”, the switch function will be:**A. When system is power off :**

A short click on this switch, the system will be powered on.

B. When system power is on :**a. The system is in Full-ON mode :**

a-1. Click on this switch (less than 4 seconds), the system will be turned into Suspend mode. (get into a GREEN mode)

a-2. Press and hold this switch for more than 4 seconds, the system will be powered off.

- b. When the system is in Suspend mode :
 - b-1. Click on this switch (less than 4 seconds), the system will return to Full-ON mode.

 - b-2. Press and hold this switch more than 4 seconds, the system will be powered off.

② **The setup in CMOS is “Instant-off”:**

- A. When system power is off :

Click on this switch, the system will be powered on.

- B. When system power is on :

Click on this switch, the system will be powered off instantly.

- 5-b. When this mainboard has the AT power supply connected, the PW switch can only be used as the suspend switch.

- A. When the BIOS setup is “Delay 4 sec.”:

The PW switch can be used as a suspend switch. When it is first pressed, the PC system will be turned into suspend mode, when clicked again, the PC system will be back to the normal state.

- B. When the BIOS setup is “Instant off”:

The PW switch does not have any function on it. If you want to power ON/OFF the PC system, you will have to use the power switch on the power supply.

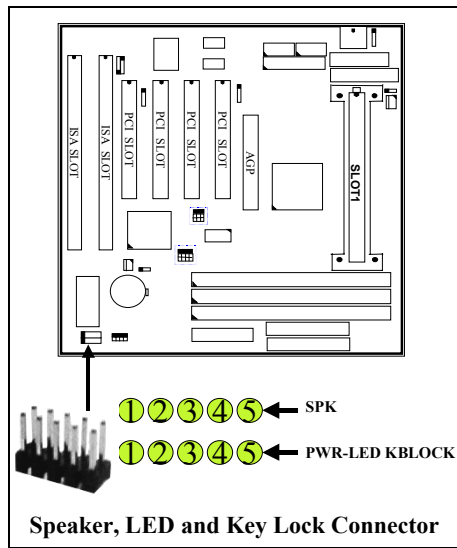
(R) Speaker, LED and Key Lock Connector:**SPK: Speaker connector**

1	<u>Pin #</u>	<u>Signal name</u>
<input type="checkbox"/>	1	+ 5V DC
<input type="checkbox"/>	2	Speaker Data Signal
<input type="checkbox"/>	3	Speaker Data Signal
<input type="checkbox"/>	4	Speaker Data Signal
<input type="checkbox"/>	5	No Connection

5

PWR-LED & KBLOCK: Panel Power LED and Key-Lock Connector

1	<u>Pin #</u>	<u>Signal name</u>
<input type="checkbox"/>	1	Pullup (+ 5V DC for Power LED)
<input type="checkbox"/>	2	Ground
<input type="checkbox"/>	3	Ground
<input type="checkbox"/>	4	Keyboard Lock
<input type="checkbox"/>	5	Ground

5

3.3 JUMPERS

This section will discuss the jumper setting on this mainboard. In order to let you have better idea of the jumper setting, please see below for the explanation of jumper settings before you start this section. A jumper is a set of two, three or more jumper pins which allows users to make different system configuration by putting the plastic connector plug (mini-jumper) on it..

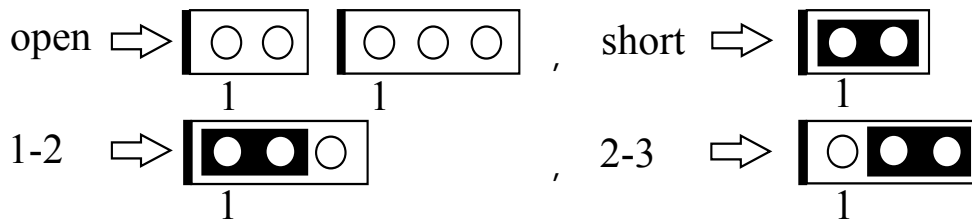

The following jumpers which labeled with “optional” means they are optional on the mainboard and the related components are normally not populated on the board. In order to make the mainboard works properly, please make sure all jumper settings are at correct before installing this mainboard.

(A) JP1: Keyboard OnNow Function Selection

This mainboard supports the OnNow function. The OnNow function will allow you to use Keyboard password to power on the PC system. Some keyboards may not support the OnNow function and it will cause trouble to your PC system. Should it happened, please use JP1 to disable the OnNow function

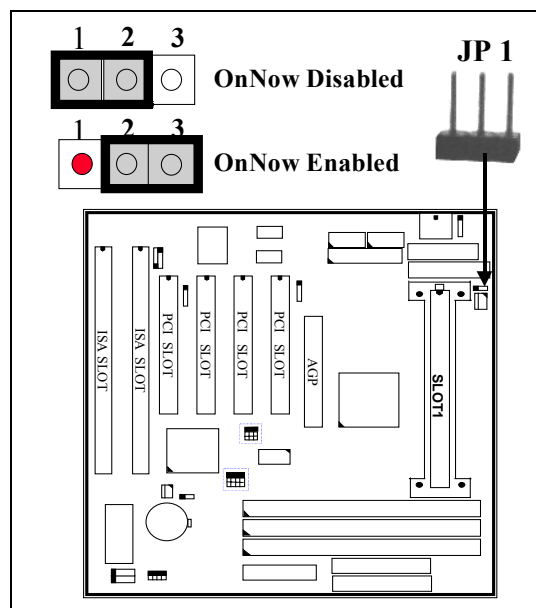

- (B) JP2, JP3, JP4: Clock Selection for system BUS, AGP and PCI slot (optional)**
 JP2 JP3 and JP4 is designed on the mainboard to select the clock speed of the system Bus, AGP and PCI. Basically, the clock speed for this devices can be selected in the BIOS setup program. So you will find that these jumper is optional on the board, When these jumpers is installed on the mainboard, you have to select "default" setting in the BIOS setup program first and then you can use these jumpers to select system Bus, AGP and PCI clock. (*Note: the setting in the system BIOS has the higher priority than the jumper setting.*)

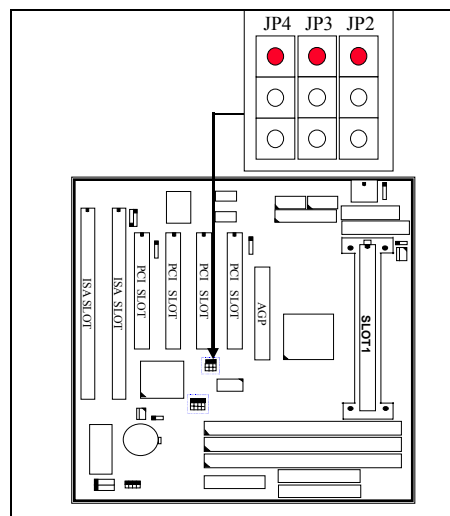

JP2	JP3	JP4	BUS CLOCK	AGP CLOCK	PCI CLOCK
2-3	2-3	2-3	112 MHz	74.7 MHz	37.3 MHz
2-3	2-3	1-2	66.8 MHz	66.8 MHz	33.4 MHz
2-3	1-2	2-3	124 MHz	82.7 MHz	41.3 MHz
2-3	1-2	1-2	75 MHz	75 MHz	37.5 MHz
1-2	2-3	2-3	133.3 MHz	88.7 MHz	44.3 MHz
1-2	2-3	1-2	83.3 MHz	66.6 MHz	33.3 MHz
1-2	1-2	2-3	95 MHz	63.5 MHz	31.75 MHz
1-2	1-2	1-2	100 MHz	66.6 MHz	33.3 MHz

Note **1-2: means mini jumper on Pin1 and Pin2**
 2-3: means mini jumper on Pin3 and Pin3

The BUS clock mentioned in the table above is the system bus clock which will be connected to the system devices such as CPU, MIMM ... etc. When the BUS clock is defined in the BIOS setup program, the setting on these jumpers will not make any change to the BUS clock. (CPU will use BUS clock and have it multiplied with the clock ratio and decide the system speed.)

(C) JP5, JP6, JP7, JP8: CPU Clock Ratio Selection (optional)

JP5 JP6, JP7 and JP8 is designed on the mainboard to select the CPU clock ratio. Basically, the CPU clock ratio can be selected in the BIOS setup program,. So you may find these jumpers are not presented on the board, When these jumpers are installed on the mainboard, you have to "Disable" the "Processor Core Frequency" in BIOS setup program before you can use these jumper settings to select the CPU clock ratio. (*Note: the setting in the system BIOS has the higher priority than the jumper setting.*)

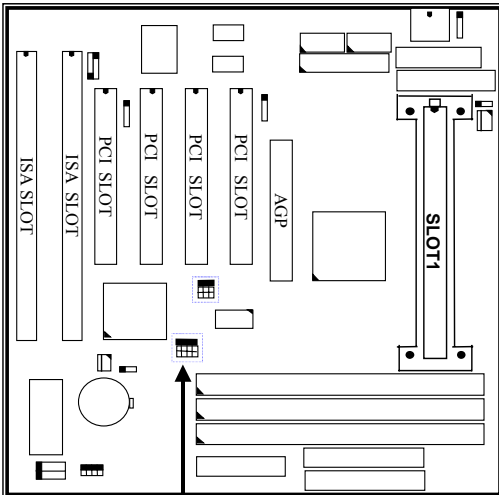

Clock	Ratio	JP5	JP6	JP7	JP8
233MHz	66*3.5X	2-3	1-2	2-3	1-2
266MHz	66* 4.0X	2-3	2-3	1-2	2-3
300MHz	66* 4.5X	2-3	1-2	1-2	2-3
333MHz	66* 5.0X	2-3	2-3	1-2	1-2
366MHz	66* 5.5X	2-3	1-2	1-2	1-2
400MHz	66* 6.0X	1-2	2-3	2-3	2-3
350MHz	100* 3.5X	2-3	1-2	2-3	1-2
400MHz	100* 4.0X	2-3	2-3	1-2	2-3
450MHz	100* 4.5X	2-3	1-2	1-2	2-3
500MHz	100* 5.0X	2-3	2-3	1-2	1-2

JP8	JP7	JP6	JP5
●	●	●	●
●	●	●	●
●	●	●	●

1-2 = Mini jumper on Pin1 & Pin2

2-3 = Mini jumper on Pin2 & Pin3

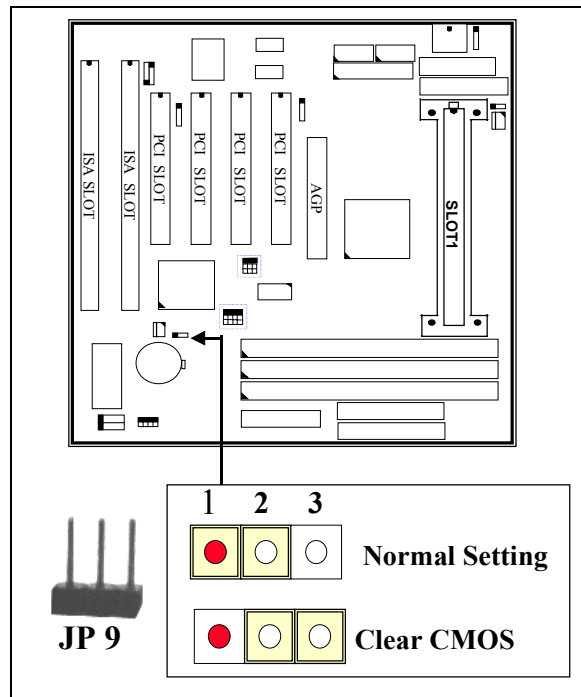
(D) JP9: CMOS Data Clear Button

Note: Improper BIOS setting may cause PC system hang-up, In case that it happened, use JP9 to clear the CMOS information and get the PC system back to normal. Improper connection may cause permanent damage to the mainboard. Please refer to the following steps to clear the CMOS

1. Unplug the AC power cable from the PC system.
2. Put the mini jumper on pin 2-3 of JP9 around 3 to 5 seconds and then return it to the original position (pin 1-2).
3. Re-connect the AC power cable.

HOW TO MAKE JUMPER SETTING TO SELECT CPU CLOCK

Basically, there are two parameters which will decide the system speed - the Front Side Bus (FSB) speed (it is also called BUS clock) and CPU clock ratio. When you have installed the processor onto the mainboard, the system BIOS will detect the CPU type and decide the FSB speed automatically if you have told the system BIOS to use the "*default*" setting. (please refer to **section 4-6** – “CPU Host Clock (CPU/AGP)”). As for the clock ratio, it is selected either by BIOS setup program or by the jumper setting on JP7, JP8 and JP9 as shown above. The following formula is the simple rule to calculate your CPU frequency:

$$\text{FSB Clock} \times \text{Clock Ratio} = \text{CPU Frequency}$$

SELECTION OF FSB CLOCK (please refer to section 4.6)

Different processors may have the different FSB clock and you will see the information from the data sheet which comes with the CPU package. However, when you have installed the processor onto the mainboard, the system BIOS will detect the type of the processor and decide the proper FSB clock automatically. (you can use either the BIOS setup program or JP5, JP6, JP7 and JP8 to select other FSB clock) The brief reference of FSB clock for different processors are shown as followings:

Processors for 66MHz FSB clock:

Pentium™ II-233, 266, 300 and 333MHz processors

Celeron™ -266, 300, 300A, 333 and 366MHz processors

Processors for 100MHz FSB clock:

Pentium™ II-350, 400, 450 and 500MHz processors

HOW TO DECIDE THE CPU CLOCK RATIO:

Modify the formula mentioned mentioned above and we will get:

$$\text{CPU Frequency} \div \text{FSB Clock} = \text{Clock Ratio}$$

Now we can use the formula above to calculate the CPU clock ratio. Please refer to the following illustration for the calculation:

For example, if you are installing the 350MHz Pentium™ II processor onto the mainboard. You may look into the data sheet which comes with the processor or the information in the previous page and you will see the FSB clock is 100MHz.

Now you may introduce these parameters into the formula and get:

$$350\text{MHz (CPU Frequency)} \div 100\text{MHz (FSB Clock)} = 3.5\text{X (Clock Ratio)}$$

According to the example above, you can see that it is very easy to calculate the CPU clock ratio when you have the information of your information of CPU frequency and its FSB speed. In order to let you have a better picture of the calculation, the procedures are summarized as following:

1. Check the data sheet for your CPU frequency.
2. Check the data sheet and get the FSB clock of your CPU.
3. Use the following formula to calculate the CPU clock ratio.

$$\text{CPU Frequency} \div \text{FSB Clock} = \text{Clock Ratio}$$

4. AWARD BIOS SETUP

4.1 GETTING STARTED

When the system is first time powered on or reset by user, the BIOS will enter the Power On Self Test routines (POST, which will display a copyright message on the screen and execute a diagnostics and initialization procedure.) In case that there is any error or malfunction detected, the BIOS will give a series of beep sound or display the error message on screen.

When the system is normal, the simulate figure *Fig. 5-1* will be displayed on the screen when the system is powered on.

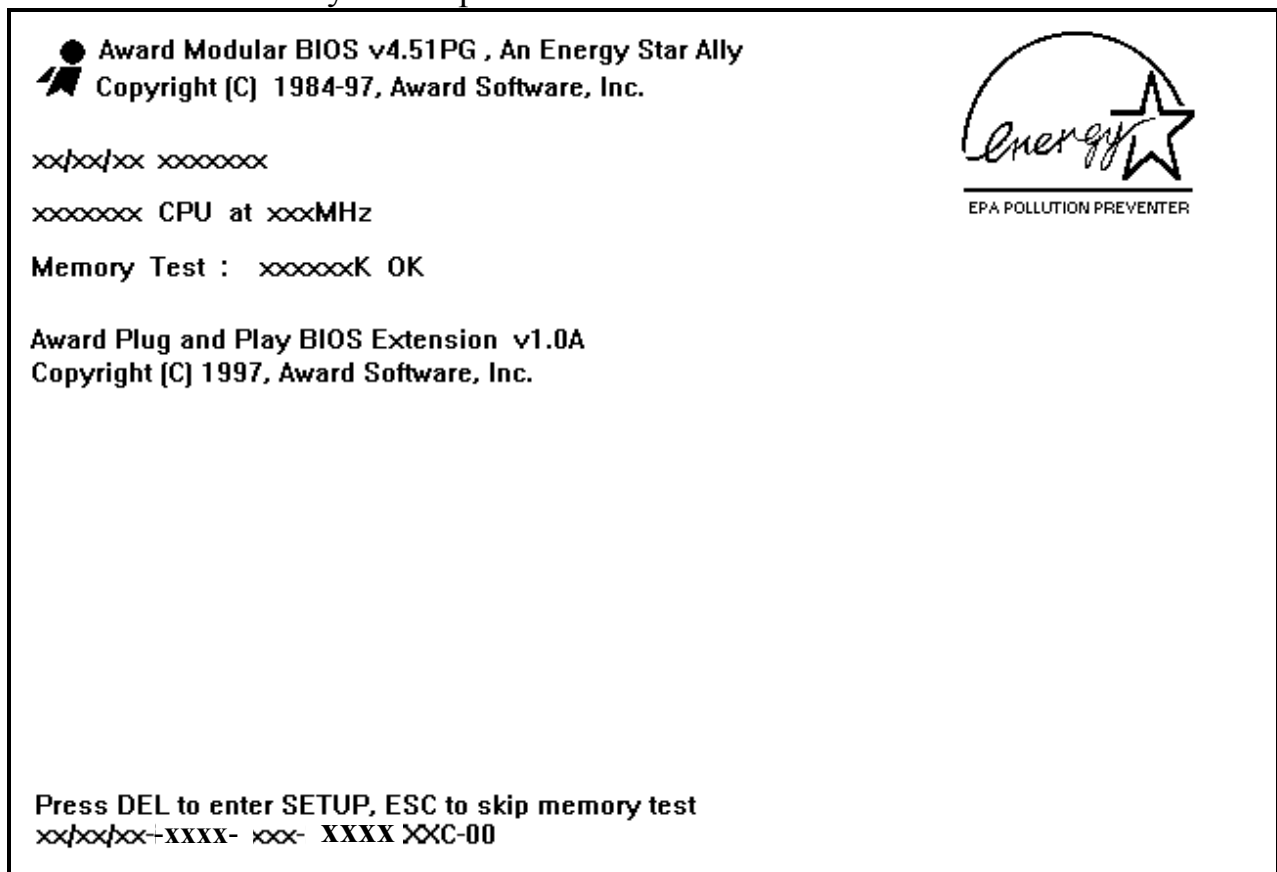

Fig. 4-1 Initial Power-On screen.

During the power on self testing (POST), the following message appears at the lower left corner of the screen:

" Press **DEL** to enter SETUP "

To execute the Award® BIOS CMOS Setup program, please press the "DEL" key. The STANDARD CMOS SETUP screen as shown in figure Fig. 5-2 will be triggered:

4.2 MAIN MENU

ROM PCI / ISA BIOS (2A6ILP8A)												
CMOS SETUP UTILITY												
AWARD SOFTWARE, INC.												
<table border="1" style="width: 100%; border-collapse: collapse;"> <tr> <td style="background-color: black; color: white; padding: 2px;">STANDARD CMOS SETUP</td> </tr> <tr> <td>BIOS FEATURES SETUP</td> </tr> <tr> <td>CHIPSET FEATURES SETUP</td> </tr> <tr> <td>POWER MANAGEMENT SETUP</td> </tr> <tr> <td>PNP/PCI CONFIGURATION</td> </tr> <tr> <td>INTEGRATED PERIPHERALS</td> </tr> <tr> <td>LOAD SETUP DEFAULTS</td> </tr> </table>	STANDARD CMOS SETUP	BIOS FEATURES SETUP	CHIPSET FEATURES SETUP	POWER MANAGEMENT SETUP	PNP/PCI CONFIGURATION	INTEGRATED PERIPHERALS	LOAD SETUP DEFAULTS	<table border="1" style="width: 100%; border-collapse: collapse;"> <tr> <td>PASSWORD SETTING</td> </tr> <tr> <td>IDE HDD AUTO DETECTION</td> </tr> <tr> <td>SAVE & EXIT SETUP</td> </tr> <tr> <td>EXIT WITHOUT SAVING</td> </tr> </table>	PASSWORD SETTING	IDE HDD AUTO DETECTION	SAVE & EXIT SETUP	EXIT WITHOUT SAVING
STANDARD CMOS SETUP												
BIOS FEATURES SETUP												
CHIPSET FEATURES SETUP												
POWER MANAGEMENT SETUP												
PNP/PCI CONFIGURATION												
INTEGRATED PERIPHERALS												
LOAD SETUP DEFAULTS												
PASSWORD SETTING												
IDE HDD AUTO DETECTION												
SAVE & EXIT SETUP												
EXIT WITHOUT SAVING												
<table border="1" style="width: 100%; border-collapse: collapse;"> <tr> <td style="width: 50%;">ESC : Quit</td> <td style="width: 50%;">□□□□ : Select Item</td> </tr> <tr> <td>F10 : Save & Exit Setup</td> <td>(Shift)F2 : Change Color</td> </tr> </table>		ESC : Quit	□□□□ : Select Item	F10 : Save & Exit Setup	(Shift)F2 : Change Color							
ESC : Quit	□□□□ : Select Item											
F10 : Save & Exit Setup	(Shift)F2 : Change Color											
Time, Date, Hard Disk Type ...												

Fig. 4-2 CMOS SETUP MAIN MENU screen.

4.3 CONTROL KEYS

Listed below is the explanation of the keys displayed at the bottom of the screens which will be used in the CMOS SETUP program :

- Arrow Keys** : Use the arrow keys to move the cursor to the desired item.
- Enter** : Select the desired item.
- F1** : Display the help screen for the selected feature.
- (Shift)F2** : To change the screen color, total 16 colors.
- ESC** : Exit to the previous screen.
- PgUp(-)/PgDn(+)** : To modify or change the content of the highlighted item.
- F5** : Retrieves the previous value from CMOS data, (only the current page setup will be retrieved).
- F7** : Loads the SETUP default values from BIOS default table, (only the current page setup will be loaded).
- F10** : Save all changes to CMOS RAM from the MAIN MENU

The following pages show the screens that you will find in the CMOS SETUP program, each picture contains the selection items and its default settings. At the bottom of some screen, you will find the description of all function key which can be used to change the settings. If you are not quite sure of the definition for some specific items, please consult with other technician for details.

4.4 STANDARD CMOS SETUP

ROM PCI / ISA BIOS (2A6ILP8A)
STANDARD CMOS SETUP
AWARD SOFTWARE, INC.

Date (mm : dd : yy) : Thr, May 7 1998	
Time (hh : mm : ss) : 14 : 59 : 21	
HARD DISKS	TYPE SIZE CYLS HEAD PRECOMP LANDZ SECTOR MODE
Primary Master	Auto 0 0 0 0 0 0 Auto
Primary Slave	None 0 0 0 0 0 0 -----
Secondary Master	Auto 0 0 0 0 0 0 Auto
Secondary Slave	None 0 0 0 0 0 0 -----
Drive A : 1.44M, 3.5 in.	Base Memory : 640 K Extended Memory : xxxxxx K Other Memory : xxxxxx K <hr/> Total Memory : xxxxxx K
Drive B : None	
Floppy 3 mode support : Disabled	
Video : EGA/VGA	
Halt On : All Errors	
ESC : Quit	<input type="checkbox"/> <input type="checkbox"/> <input type="checkbox"/> <input type="checkbox"/> : Select Item
F1 : Help	(Shift)F2 : Change Color
	PU/PD/+/- : Modify

Fig. 4-3 STANDARD CMOS SETUP screen.

MODE :

The BIOS on the mainboard provides three different modes to support both normal IDE HDD and the one which is above 528MB:

- NORMAL** : For IDE hard disk drives which is smaller than 528MB.
- LBA** : For IDE hard disk drive which is above 528MB (ideally, it can be as big as 8.4GB) that use Logic Block Addressing (LBA) mode.
- LARGE** : For IDE HDD which is above 528MB and does not support LBA mode.
Note : "large mode" may not be fully supported by all operation systems. It is suggested to be used with the MS-DOS, such HDD is not very popular nowadays.
- AUTO** : This mode will auto-detect your IDE driver during boot-up.

(Note: Some certain operation systems (such as SCO®-UNIX™), only "NORMAL mode" is allowed when installation.)

Floppy 3 Mode Support: (Default setting: disabled)

This mode is for the Japanese 3.5 inch floppy disk drive. If you have such drive installed in your PC system, please select enable, otherwise, use the default setting.

4.5 BIOS FEATURES SETUP

ROM PCI / ISA BIOS (2A6ILP8A)

BIOS FEATURES SETUP

AWARD SOFTWARE, INC.

Virus Warning	: Disabled	Video BIOS Shadow	: Enabled
CPU Internal Cache	: Enabled	C8000-CBFFF Shadow	: Disabled
External Cache	: Enabled	CC000-CFFFF Shadow	: Disabled
CPU L2 Cache ECC Checking	: Enabled	D0000-D3FFF Shadow	: Disabled
Quick Power On Self Test	: Enabled	D4000-D7FFF Shadow	: Disabled
Boot Sequence	: A,C,SCSI	D8000-DBFFF Shadow	: Disabled
Swap Floppy Drive	: Disabled	DC000-DFFFF Shadow	: Disabled
Boot Up Floppy Seek	: Enabled		
Boot Up NumLock Status	: On		
Boot Up System Speed	: High		
Memory Parity Check	: Enabled		
Typematic Rate Setting	: Disabled		
Typematic Rate (Chars/Sec)	: 6		
Typematic Delay (Msec)	: 250		
Security Option	: Setup	ESC : Quit	<input type="checkbox"/> <input type="checkbox"/> <input type="checkbox"/> <input type="checkbox"/> : Select Item
PCI/VGA Palette Snoop	: Disabled	F1 : Help	PU/PD/+/- : Modify
Assign IRQ For VGA	: Enabled	F5 : Old Values	(Shift)F2 : Color
OS Select For DRAM > 64MB	: Non-OS2	F7 : Load Setup Defaults	
Report No FDD For WIN 95	: Yes		

Fig. 4-4 BIOS FEATURES SETUP screen.

Virus Warning :

Basically, The default setting of this feature is "Disabled", In order to avoid virus infection happens on your PC system, this mainboard provides the virus warning features in the BIOS. During and after the operation system is loaded, any attempt to write to the boot sector or partition table on the IDE hard disk drive will trigger this feature and give you some warning messages on the screen and then halt the system. When you find the message on your screen, please run the anti-virus program to see whether your system is infected by a virus or not.

Enabled : A warning message will be displayed on the screen when something

attempts to access the boot sector or hard disk partition table.

Disabled : No warning message will appear on the screen when anything attempts to access the boot sector or hard disk partition table.

CPU Internal / External Cache : (default setting: Enabled)

These fields allow you to turn on or turn off the Level 1 and Level 2 cache that built inside the Pentium™ II processors.

CPU L2 Cache ECC Checking: (default setting: Enabled)

This option will enable or disable the ECC checking on the CPU L2 cache. The ECC checking will ensure the accuracy of the data stored on the L2 cache.

Quick Power on Self Test: (default setting: Enabled)

The Quick Power On Self Test will skip some test and speed up the boot process. If you find the system is working normally, you can always enable this feature so that you don't have to wait too long on the POST.

Boot Sequence : (default setting: A,C,SCSI)

This field allows you to use some other device to boot the operating system. The options available are "A,C,SCSI", "C,A,SCSI", "C,CDROM,A", "CDROM,C,A", "D,A,SCSI", "E,A,SCSI", "F,A,SCSI", "SCSI,A,C", "SCSI,C,A", "C only" and "LS/ZIP,C".

When select to load the OS from "CDROM,C,A" or "LS/ZIP,C", you must select the "HARD DISK TYPE and MODE" properly, the "Auto" selection is recommended so that you can use CDROM or LS/ZIP device to load the OS into your system. (You can find these items in the "STANDARD CMOS SETUP")

Swap Floppy Drive : (default setting: Disabled)

When enable this option, the device name of the floppy drives will be swapped, For example, drive A will be treated as drive B, and drive B as Drive A.

Boot Up Floppy Seek : (default setting: Enabled)

Enable this feature will tell the system to seek and check on the floppy drive when boot up the system.

Boot Up NumLock Status : (default setting: On)

Select "ON" in this field will light the " **NumLock LED**" when boot up the system. When select "Off", the Numlock LED will be darkened.

Boot Up System Speed : (default setting: High)

The field allows you to select the system speed, the default setting is "High"

Memory Parity Check : (default setting: Enabled)

When select "Enabled", the system board will use the parity bit to check the memory sub-system. When select "Disabled", the system board will not check the parity bit.

Assign IRQ for VGA : (default setting: Enabled)

Some of the VGA display card has some additional feature on the board and it may need the IRQ signal. When the system board need more IRQ signal for other devices and your VGA does not use the IRQ, you may select "Disable" on this field to release IRQ so that other devices can use it.

OS Select For DRAM > 64MB : (default setting: Non-OS/2)

When you are using the "OS/2™" operating system and the system memory is more than 64MB, you will have to select the setting to "OS2", otherwise, leave this on the default setting "Non-OS2" for all other operating systems.

4.6 CHIPSET FEATURES SETUP

ROM PCI / ISA BIOS (2A6ILP89)

CHIPSET FEATURES SETUP

AWARD SOFTWARE, INC.

Auto Configuration	: Disabled	AGP Aperture Size	: 64MB
RAS Pulse Width Refresh	: 6T	System BIOS Cacheable	: Disabled
RAS Precharge Time	: 3T	Video BIOS Cacheable	: Disabled
RAS to CAS Delay	: 3T	Memory Hole at 15-16MB	: Disabled
CPU to PCI post Write	: Enabled	Concurrent function (MEM)	: Disabled
Starting Point of Paging	: 2T		
ECC Function for Bank 0	: Disabled		
ECC Function for Bank 1	: Disabled	CPU Pipeline Control	: Enabled
ECC Function for Bank 2	: Disabled	PCI Delay Transaction	: Disabled
SDRAM CAS Latency	: 3T	Auto Detect DIMM/PCI Clk	: Enabled
SDRAM WR Retire Rate	: x-1-1-1	Spread Spectrum	: Disabled
SDRAM Wait State Control	: 1WS	CPU Host Clock (CPU/AGP)	: Default
RAMW#Assertion Timing	: 3T	CPU Clock Ratio Jumpless	: Enabled
CAS Precharge Time (EDO)	: 2T	Processor Core Frequency	: x 3.5
CAS# Pulse Width for EDO	: 2T		
CAS Precharge Time (FP)	: 2T	ESC : Quit	<input type="checkbox"/> <input type="checkbox"/> <input type="checkbox"/> <input type="checkbox"/> : Select Item
CAS# Pulse Width for FP	: 2T	F1 : Help	PU/PD/+/- : Modify
CPU to PCI Burst Mem. WR.	: Enabled	F5 : Old Values	(Shift)F2 : Color
SDRAM Input Signals	: Delay 0.5ns	F7 : Load Setup Defaults	
SDRAM Output Signals	: Lead 0.0ns		

Fig. 4-5 CHIPSET FEATURES SETUP screen.

This section allows you to configure the system based on the specific features of the installed chipset. This chipset manages bus speeds and access to system memory resources, such as DRAM and the external cache. It also coordinates communications between the conventional ISA bus and the PCI bus. It must be stated that these items should never need to be altered. The default settings have been chosen because they provide the best operating conditions for your system. The only time you might consider making any changes would be if you discovered that data was being lost while using your system

WARNING : *The selection fields on this screen are provided for the professional technician who can modify the Chipset features to meet some specific requirement. If you do not have the related technical background, do not attempt to make any change except the following items.*

Auto Configuration (default setting : “Disabled”)

This item allows you to select pre-determined optimal values of chipset parameters. When "Disabled", chipset parameters revert to setup information stored in CMOS. Many fields in this screen are not available when Auto Configuration is "Enabled".
The Choice: Enabled, Disabled.

Note: When this item is enabled, the pre-defined items will become SHOW-ONLY.

RAS Pulse Width Refresh (default setting : “6T”)

The item allows you to select the number of CPU clock cycles allot for the RAS pulse refresh, according to DRAM specifications.

The choice: 4T, 5T, 6T, 7T.

RAS Precharge Time (default setting : “3T”)

The precharge time is the number of cycles it takes for the RAS to accumulate its charge before DRAM refresh. If insufficient time is selected, refresh may be incomplete and the DRAM may fail to retain data.

The Choice: 2T, 3T, 4T, 5T.

RAS to CAS Delay (default setting : “3T”)

When DRAM is refreshed, both rows and columns are addressed separately. This setup item allows you to determine the timing of the transition from RAS (row address strobe) to CAS (column address strobe).

The choice: 2T, 3T, 4T, 5T.

CPU to PCI Post Write (default setting : “Enabled”)

Select enabled to use a fast buffer for posting writes to memory. Using a fast buffer releases the CPU before completion of a write cycle to DRAM.

The choice: Enable, Disabled.

Starting Point of Paging (default setting : “2T”)

This value controls the start timing of memory paging operations.

The choice: 1T, 2T, 4T, 8T.

ECC Function for Bank 0/1/2 (default setting : “Disabled”)

Enable/Disable the ECC function for Bank 0/1/2.

The choice: Enabled, Disabled.

SDRAM CAS Latency (default setting : “3T”)

When synchronous DRAM is installed, the number of clock cycles of CAS latency depends on the DRAM timing. Do not reset this field from the default value unless you have the sufficient technical background.

The choice: 2T, 3T.

SDRAM WR Retire Rate (default setting : “x-1-1-1”)

The field is designed to select the correct timing for data transfers from the write buffer to memory, according to DRAM specifications. Do not reset this field from the default value unless you have the sufficient technical background.

The choice: x-1-1-1, x-2-2-2

SDRAM WR Retire Rate (default setting : “1WS”)

The field is designed to select the wait state of memory sub-system.

The choice: 1WS, 0WS

RAMW# Assertion Timing (default setting : “3T”)

RAMW is an output signal to enable local memory writes. Do not attempt to make change to this field from the default value unless you have the sufficient technical background.

The choice: 2T, 3T.

CAS Precharge Time (EDO) (default setting : “2T”)

Select the number of CPU clocks allocated for the CAS# signal to accumulate its charge before the EDO RAM is refreshed. If insufficient time is selected, refresh may be incomplete and cause data lost.

The choice: 1T, 1T/2T, 2T.

CAS# Pulse Width for EDO (default setting : “2T”)

The selection field allows you to select the duration of a CAS signal pulse (in timer ticks). Do not attempt to make change to this field from the default value unless you have the sufficient technical background.

The choice: 0T, 2T.

CAS Precharge Time (FP) (default setting : “2T”)

This item allows you to select CAS precharge time for FP RAM. Do not attempt to make change to this field from the default value unless you have the sufficient technical background.

The choice: 1T, 1T/2T, 2T.

CAS# Pulse Width for FP (default setting : “2T”)

The item allows you to select duration of a CAS signal pulse for FP RAM. Do not attempt to make change to this field from the default value unless you have the sufficient technical background.

The choice: 1T, 2T, 0T.

CPU to PCI Burst Mem. WR (default setting : “Enabled”)

Select enabled permits PCI burst memory write cycles, for faster performance. When disabled, performance is slightly slower, but more reliable.

Choices are Enabled, Disabled.

AGP Aperture Size (default setting : “64MB”)

Select the size of the Accelerated Graphics Port (AGP) aperture. The aperture is a portion of the PCI memory address range dedicated for graphics memory address space. Host cycles that hit the aperture range are forwarded to the AGP without any translation. See www.agpforum.org for APG information.

The choice: 4 MB, 8MB, 16 MB, 32 MB, 64 MB, 128 MB, 256MB.

System BIOS Cacheable Size (default setting : “Disabled”)

Select "*Enabled*" allows caching of the system BIOS ROM at F0000h-FFFFh, resulting in better system performance. However, if any program writes to this memory area, a system error may result.

The choice: Enabled, Disabled.

Video BIOS Cacheable (default setting : “Dosabled”)

Select "*Enabled*" allows caching of the system BIOS ROM at C0000h-F7FFFh, resulting in better system performance. However, if any program writes to this memory area, a system error may result.

The choice: Enabled, Disabled.

Memory Hole at 15M-16M (default setting : “Dosabled”)

You can reserve this area of system memory for ISA adapter ROM. When this area is reserved, it cannot be cached. The user information of peripherals that need to use this area of system memory usually discusses their memory requirements.

Concurrent function <MEM> (default setting : “Dosabled”)

This field allows you to Enable/disable the concurrent function for memory.

The choice: Enabled, Disabled.

CPU Pipeline Control (default setting : “Enabled”)

Pipelining allows the system controller to signal the CPU for a new memory address even before all data transfers for the current cycle are complete, resulting in increased throughput.

PCI Delay Transaction (default setting : “Disabled”)

The chipset has an embedded 32-bit posted write buffer to support delay transactions cycles. Select "*Enabled*" to support compliance with PCI specification version 2.1.

The choice: Enabled, Disabled.

Auto Detect DIMM / PCI Clk (default setting : “Enabled”)

When enabled, the system board will detect the clock speed for DIMM and PCI clock.

The choice: Enabled, Disabled.

Spread Spectrum: (Default setting: “Disabled”)

When you select “Enabled”, the special feature designed in the system chipset will be triggered and reduce the EMI noise.

The choice: Enabled, Disabled.

CPU Host Clock (CPU/AVG): (default setting : “Default”)

This field allows you to select the CPU/AGP clock speed. the jumper-free feature is designed on the board and you can use the selection in this field to decide the CPU/AGP clock. For more information, please press the "F1" key.

CPU Clock Ratio Jumpless (default setting : “Enabled”)

The "Jumper-free" feature is designed on the board and you don't have to use the jumper setting to select the CPU clock ratio. If you want to use the jumper setting (it is optional) to select the CPU clock ratio, please select "Disabled".

Processor Core Frequency (default setting : “ x 3.5”)

When "CPU Clock Ratio Jumpless" is **Enabled**, you can use this field to select the clock ratio. When "CPU Clock Ratio Jumpless" is **Disabled**, you will have to use Jumper setting to select the clock ratio.

Note: the CPU clock ratio selected in the system BIOS setup program always has the higher priority than the jumper settings.

4.7 POWER MANAGEMENT SETUP

ROM PCI / ISA BIOS (2A6ILP8A)

POWER MANAGEMENT SETUP

AWARD SOFTWARE, INC.

ACPI function	: Enabled	IRQ [3-7 , 9-15], NMI	: Enabled
Power Management	: User Define	IRQ 8 Break Suspend	: Disabled
PM Control by APM	: Yes	Power Button Over Ride	: Instant Off
Video Off Option	: Susp, Stby → off	Ring Power Up Control	: Disabled
Video Off Method	: Blank Screen		
Doze speed (div by)	: 2 / 8	KB Power ON Password	: Enter
Stby speed (div by)	: 1 / 8	Power Up by Alarm	: Disabled
Modem Use IRQ	: 3		
** PM Timers **			
HDD Off After	: Disable		
Doze Mode	: Disable		
Standby Mode	: Disable		
Suspend Mode	: Disabled		
** PM Events **			
HDD Ports Activity	: Enabled	ESC : Quit	<input type="checkbox"/> <input type="checkbox"/> <input type="checkbox"/> <input type="checkbox"/> : Select Item
COM Ports Activity	: Enabled	F1 : Help	PU/PD/+/- : Modify
LPT Ports Activity	: Enabled	F5 : Old Values	(Shift)F2 : Color
VGA Activity	: Enabled	F7 : Load Setup Defaults	

Fig. 4-6 POWER MANAGEMENT SETUP screen.

WARNING : The selection fields on this screen are provided for the professional technician who can modify the Chipset features to meet some specific requirement. If you do not have the related technical background, do not attempt to make any change except the following items.

ACPI function : (Default setting: “Enabled”)

This field allows you to enable or disable the ACPI function (Advanced Configuration and Power Interface):

The choice: Enabled, Disabled.

Power Management : (Default setting: “User Define”)

This category allows you to select the type (or degree) of power saving and is directly related to the following modes:

1. Doze Mode
2. Standby Mode
3. Suspend Mode

The following table describes the power management modes:

Disable (default)	No power management. Disables all four modes
Min. Power Saving	Minimum power management. Doze Mode = 1 hr. Standby Mode = 1 hr., Suspend Mode = 1 hr., and HDD Power Down = 15 min.
Max. Power Saving	Maximum power management -- ONLY AVAILABLE FOR SL CPU'S. Doze Mode = 1 min., Standby Mode = 1 min., Suspend Mode = 1 min., and HDD Power Down = 1 min.
User Defined	Allows you to set each mode individually. When not disabled, each of the ranges are from 1 min. to 1 hr. except for HDD Power Down which ranges from 1 min. to 15 min. and disable.

PM Control APM: (Default setting: “Yes”)

When enabled, an Advanced Power Management device will be activated to enhance the Max. Power Saving mode and stop the CPU internal clock.

If the Max. Power Saving is not enabled, this will be preset to *No*.

Video Off Option (Default setting: “Susp, Stby -> Off”)

When enabled, this feature allows the VGA adapter to operate in a power saving mode.

Always On	Monitor will remain on during power saving modes.
Suspend --> Off	Monitor blanked when the systems enters the Suspend mode.
Susp,Stby --> Off	Monitor blanked when the system enters either Suspend or Standby modes.
All Modes --> Off	Monitor blanked when the system enters any power saving mode.

Video Off Method: (Default setting: Blank screen)

This determines the manner in which the monitor is blanked.

V/H SYNC+Blank	This selection will cause the system to turn off the vertical and horizontal synchronization ports and write blanks to the video buffer.
Blank Screen	This option only writes blanks to the video buffer.
DPMS	Select this option if your monitor supports the Display Power Management Signaling (DPMS) standard of the Video Electronics Standards to select video power management values.

Doze Speed (div by) (Default setting: 2 /8)

Sets the CPU's speed during Doze mode. The speed is reduced to a fraction of the CPU's normal speed. The divisors range from 1 to 8
The choice: 1~8.

Stdby Speed (div by) (Default setting: 1 /8)

Select a divisor to reduce the CPU speed during *Standby* mode to a fraction of the full CPU speed. The speed is reduced to a fraction of the CPU's normal speed. The divisors range from 1 to 8-0.
The choice: 1~8

Modem Use IRQ: (Default setting: 3)

This mainboard has the ACPI feature designed on the board and it will “wakeup” automatically when it detects the incoming modem Ring-in signal. Before you can use the Ring-in signal to wakeup your PC system, you have to install the “External” modem to your PC system and tell the PC system which serial port connects to the modem by selecting the IRQ in this field. (officially, COM1 uses IRQ4, and COM2 uses IRQ3)

The choices: NA, 3, 4, 5, 7, 9, 10, 11, NA

**** PM Timers ****

The following four modes are Green PC power saving functions which are only user configurable when *User Defined* Power Management has been selected. See above for available selections

HDD Off After (Default setting: Disable)

By default, this item is Disabled, meaning that no matter the mode the rest of the system, the hard drive will remain ready. Otherwise, you have a range of choices from 1 to 15 minutes or Suspend. This means that you can elect to have your hard disk drive be turned off after a selected number of minutes or when the rest of the system goes into a Suspend mode

Doze Mode: (Default setting: Disable)

When enabled and after the set time of system inactivity, the CPU clock will run at slower speed while all other devices still operate at full speed.

Standby Mode: (Default setting: “Disable “)

When enabled and after the set time of system inactivity, the fixed disk drive and the video would be shut off while all other devices still operate at full speed

Suspend Mode: (Default setting: “Disable “)

When enabled and after the set time of system inactivity, all devices except the CPU will be shut off.

**** PM Events ****

You may disable activity monitoring of some common I/O events and interrupt requests so they do not wake up the system.

When *On* (or named, in the case of LPT & COM), any activity from one of the listed system peripheral devices or IRQs wakes up the system

HDD Ports Activity (Default setting: "Enabled ")

When select "Enabled" (default), any event occurring at a HDD (serial) port will awaken a system which has been powered down.

COM Ports Activity (Default setting: "Enabled ")

When select "Enabled" (default), any event occurring at a COM ports will awaken a system which has been powered down.

LPT Ports Activity (Default setting: "Enabled ")

When select "Enabled" (default), any event occurring at a LPT (printer) port will awaken a system which has been powered down.

VGA Activity (Default setting: "Enabled ")

When select "Enabled" (default), any event occurring at VGA will awaken a system which has been powered down.

IRQ [3-7, 9-1], NMI (Default setting: "Enabled ")

When select "Enabled", activity will neither prevent the system from going into a power management mode nor awaken it.

The following is a list of IRQ's, Interrupt **Re**Quests, which can be exempted much as the COM ports and LPT ports above can. When an I/O device wants to gain the attention of the operating system, it signals this by causing an IRQ to occur. When the operating system is ready to respond to the request, it interrupts itself and performs the service.

- **IRQ [3-7, 9-15], NMI**
- **IRQ 8 Break Suspend** : You can *Enable* or *Disable* monitoring of IRQ8 (the Real Time Clock) so it does not awaken the system from Suspend mode.

Power Button Over Ride (Default setting: “Instant Off”)

You can press the power button for more than 4 seconds and forces the system to power off when select “Delay 4 Sec.”, If you select " Instant-Off ", a short click on the Power Button (PW button) will power off the PC system. (*Please refer to Section 2 for details.*)

The choice: Instant-Off, Delay 4 Sec.

Ring Power Up Control (Default setting: “Disabled”)

When you select "*Enabled*", a signal from ring from the external modem will returns the system to Full On state.

The choice: Enabled, Disabled.

Power Up by Alarm (Default setting: “Disabled”)

When you select "*Enabled*", there appear some additional selection fields. It let you set the alarm that returns the system to Full On state.

The choice: Enabled, Disabled.

4.8 INTEGRATED PERIPHERALS

ROM PCI / ISA BIOS (2A6ILP8A)

INTEGRATED PERIPHERALS

AWARD SOFTWARE, INC.

Internal PCI / IDE	: Both	PS/2 mouse function	: Enabled
IDE Primary Master PIO	: Auto	USB Controller	: Enabled
IDE Primary Slave PIO	: Auto	USB Keyboard Support	: Disabled
IDE Secondary Master PIO	: Auto	Init Display First	: PCI Slot
IDE Secondary Slave PIO	: Auto	Current CPU Temperature	: 36½C 96½F
Primary Master UltraDMA	: Auto	Current CPUFAN1 Speed	: 3970 RPM
Primary Slave UltraDMA	: Auto	Current CPUFAN2 Speed	: 0 RPM
Secondary Master UltraDMA	: Auto	IN0 (V): 11.70 V	IN1 (V): 5.12 V
Secondary Slave UltraDMA	: Auto	IN2 (V): 3.41 V	IN3 (V): 2.05 V
IDE Burst Mode	: Enabled		
IDE HDD Block Mode	: Enabled		
Onboard FDC Controller	: Enabled		
Onboard UART 1	: 3F8 / IRQ4		
Onboard UART 2	: 2F8 / IRQ3		
Onboard UART 2 Mode	: Standard		
Onboard Parallel Port	: 378 / IRQ7		
Parallel Port Mode	: Normal		

Fig. 5-7 INTEGRATED PERIPHERALS setup screen.

WARNING: *The selection fields on this screen are provided for the professional technician who can modify the Chipset features to meet some specific requirement. If you do not have the related technical background, don't attempt to make any change except the following items.*

Internal PCI / IDE (Default setting: "Both")

This chipset contains a internal PCI IDE interface with support for two IDE channels.
The choice: Primary, Secondary, Both.

IDE Primary/Secondary Master/Slave PIO (Default setting: “Auto”)

The four IDE PIO (Programmed Input/Output) fields let you set a PIO mode (0-4) for each of the four IDE devices that the onboard IDE interface supports. Modes 0 through 4 provide successively increased performance. In *Auto* mode, the system automatically determines the best mode for each device.

The choice: Auto, Mode 0, Mode 1, Mode 2, Mode 3, Mode 4.

IDE Primary/Secondary Master/Slave UDMA (Default setting: “Auto”)

UDMA (Ultra DMA) is a DMA data transfer protocol that utilizes ATA commands and the ATA bus to allow DMA commands to transfer data at a maximum burst rate of 33 MB/s. When you select *Auto* in the four IDE UDMA fields (for each of up to four IDE devices that the internal PCI IDE interface supports), the system automatically determines the optimal data transfer rate for each IDE device.

The choice: Auto, Mode 0, Mode 1, Mode 2, Mode 3, Mode 4.

IDE Burst Mode (Default setting: “Enabled”)

Selecting *Enabled* reduces latency between each drive read/write cycle, but may cause instability in IDE subsystems that cannot support such fast performance. If you are getting disk drive errors, try setting this value to *Disabled*. This field does not appear when the Internal PCI/IDE field, above, is *Disabled*.

The choice: Enabled, Disabled.

IDE HDD Block Mode (Default setting: “Enabled”)

The chipset contains a PCI IDE interface with support for two IDE channels. Select Enabled to activate the primary and/or secondary IDE interface. Select Disabled to deactivate this interface, if you install a primary and/or secondary add-in IDE interface IDE interface.

Enabled	Secondary HDD controller used
Disabled	Secondary HDD controller not used.

Onboard FDD Controller (Default setting: “Enabled”)

This item should be enabled if your system has a floppy disk drive (FDD) installed on the system board and you wish to use it. Even when so equipped, if you add a higher performance controller, you will need to disable this feature.

The choice: Enabled, Disabled.

Onboard UART 1/UART 2 (Default setting: “3F8/IRQ4, 2F8/IRQ3”)

This item allows you to determine access onboard serial port 1/port 2 controller with its IRQ and I/O address.

The choice: 3F8/IRQ4, 238/IRQ3, 3E8/IRQ4, 2F8/IRQ3, Disabled, Auto.

Onboard Parallel Port (Default setting: “378/IRQ7”)

This item allows you to determine access onboard parallel port controller with which I/O address.

The choice: 378/IRQ7, 278/IRQ5, 3BC/IRQ7, Disabled.

Onboard Parallel Mode (Default setting: “Normal”)

Select an operating mode for the onboard parallel (printer) port. Select *SPP* unless you are certain your hardware and software both support one of the other available modes.

The choice: SPP, EPP, ECP, ECP+E PP.

PS/2 mouse function (Default setting: “Enabled”)

This mainboard built-in a PS/2™ mouse port, In case that you prefer to connect your mouse to the serial port instead of using the PS/2™ mouse, you may choose “Disable” in this field so that the IRQ12 can be released for the other devices; If you are using the PS/2™ mouse, leave this field “Enabled”.

USB Controller (Default setting: “Enabled”)

Select *Enabled* if your system contains a Universal Serial Bus (USB) controller and you have USB peripherals.

The choice: Enabled, Disabled.

USB Keyboard Support (Default setting: “Disabled”)

Select Enabled if your system contains a Universal Serial Bus (USB) controller and you have a USB keyboard.

The choice: Enabled, Disabled..

Init Display First (Default setting: “PCI Slot”)

When you have both the AGP and PCI VGA card installed in the system, you can use this field to decide the display priority.

AGP Slot: the display will be active on the AGP adapter.

PCI Slot: The display will be active on the PCI VGA adapter

Current CPUFAN1/2 Speed

Indicate the speed of current CPUFAN 1 / CPUFAN 2.

IN0,1,2,3 (V)

Indicate the system voltage status.

IN0: indicates the +12V status

IN1: indicates the +5V status

IN2: indicates the +3.3V status

IN3: indicates the CPU Vcore status

4.9 PNP/PCI CONFIGURATION

ROM PCI / ISA BIOS (2A6ILP8A)

PNP/PCI CONFIGURATION

AWARD SOFTWARE, INC.

Resources Controlled By	: Manual	PCI IRQ Activated By	: Level
Reset Configuration Data	: Disabled	PCI IDE IRQ map To	: PCI-AUTO
IRQ-3 assigned to	: PCI/ISA PnP	Primary IDE INT#	: A
IRQ-4 assigned to	: PCI/ISA PnP	Secondary IDE INT#	: B
IRQ-5 assigned to	: PCI/ISA PnP	Assign IRQ For USB	: Enabled
IRQ-7 assigned to	: Legacy ISA		
IRQ-9 assigned to	: PCI/ISA PnP		
IRQ-10 assigned to	: PCI/ISA PnP		
IRQ-11 assigned to	: PCI/ISA PnP		
IRQ-12 assigned to	: PCI/ISA PnP		
IRQ-14 assigned to	: Legacy ISA		
IRQ-15 assigned to	: Legacy ISA		
DMA-0 assigned to	: PCI/ISA PnP		
DMA-1 assigned to	: PCI/ISA PnP	ESC : Quit	<input type="checkbox"/> <input type="checkbox"/> <input type="checkbox"/> <input type="checkbox"/> : Select Item
DMA-3 assigned to	: PCI/ISA PnP	F1 : Help	PU/PD/+/- : Modify
DMA-5 assigned to	: PCI/ISA PnP	F5 : Old Values	(Shift)F2 : Color
DMA-6 assigned to	: PCI/ISA PnP	F7 : Load Setup Defaults	
DMA-7 assigned to	: PCI/ISA PnP		

Fig. 4-8 PNP/PCI CONFIGURATION setup screen.

WARNING : The selection fields on this screen are provided for the professional technician who can modify the Chipset features to meet some specific

requirement. If you do not have the related technical background, do not attempt to make any change.

Resource controlled by (Default setting is “Manual”)

The Award Plug and Play BIOS has the capacity to automatically configure all of the boot and Plug and Play compatible devices. However, this capability means absolutely nothing unless you are using a Plug and Play operating system such as Windows®95.

The choice: Auto, Manual.

IRQ3/4/5/7/9/10/11/12/14/15 Assigned to

When resources are controlled manually, assign each system interrupt as one of the following types, depending on the type of device using the interrupt:

Legacy ISA Devices compliant with the original PC AT bus specification, requiring a specific interrupt (such as IRQ4 for serial port 1). PCI/ISA PnP Devices compliant with the Plug and Play standard, whether designed for PCI or ISA bus architecture.

The choice: Legacy ISA, PCI/ISA PnP

DMA0/1/3/5/6/7 assigned to

When resources are controlled manually, assign each system DMA channel as one of the following types, depending on the type of device using the interrupt:

Legacy ISA Devices compliant with the original PC AT bus specification, requiring a specific interrupt (such as IRQ4 for serial port 1). PCI/ISA PnP Devices compliant with the Plug and Play standard, whether designed for PCI or ISA bus architecture.

The choice: Legacy ISA, PCI/ISA PnP.

PCI IRQ Activated by (Default setting is “Level”)

This sets the method by which the PCI bus recognizes that an IRQ service is being requested by a device. Under all circumstances, you should retain the default configuration unless advised by qualified technicians.

The choice: *Level, Edge.*

PCI IDE IRQ Map to (Default setting is “PCI-AUTO”)

This allows you to configure your system to the type of IDE disk controller in use. By default, Setup assumes that your controller is an ISA (Industry Standard Architecture) device rather than a PCI controller. The more apparent difference is the type of slot being used.

If you have equipped your system with a PCI controller, changing this allows you to

specify which slot has the controller and which PCI interrupt (A, B,C or D) is associated with the connected hard drives.

Remember that this setting refers to the hard disk drive itself, rather than individual partitions. Since each IDE controller supports two separate hard drives, you can select the INT# for each. Again, you will note that the primary has a lower interrupt than the secondary as described in “*Slot x Using INT#*” above.

Selecting “*PCI Auto*” allows the system to automatically determine how your IDE disk system is configured.

4.10 **LOAD SETUP DEFAULTS**

ROM PCI/ISA BIOS (2A6ILP8A)
 CMOS SETUP UTILITY
 AWARD SOFTWARE, INC.

STANDARD CMOS SETUP BIOS FEATURES SETUP CHIPSET FEATURES SETUP POWER MANAGEMENT SETUP INTEGRATED PERIPHERALS PNP/PCI CONFIGURATION LOAD SETUP DEFAULTS	PASSWORD SETTING IDE HDD AUTO DETECTION SAVE & EXIT SETUP EXIT WITHOUT SAVING
ESC : Quit F10 : Save & Exit Setup	□□□□ : Select Item (Shift)F2 : Change Color
Time, Date, Hard Disk Type ...	

If you lost the CMOS data or you don't know how to complete the setup procedure, you may use this option to load the SETUP default values from the BIOS default table. It is easy to load the default value, simply highlight the "LOAD SETUP DEFAULTS" field and then press the "Enter" key, when you see the "LOAD SETUP DEFAULTS (Y/N)" displayed on the screen, response to it with "Y" and then press the "Enter" key. the SETUP default values will be loaded. Basically, the SETUP default settings are the best-case values that will optimize system performance and increase system stability.

In case that the CMOS data is corrupted, the SETUP DEFAULTS settings will be loaded automatically when you press the "Del" key and enter the main setup screen. So you may select "SAVE & EXIT SETUP" to leave setup program and the system is loaded with the default settings.

4.11 PASSWORD SETTING

ROM PCI/ISA BIOS (2A6ILP8A)
 CMOS SETUP UTILITY
 AWARD SOFTWARE, INC.

STANDARD CMOS SETUP	PASSWORD SETTING
BIOS FEATURES SETUP	IDE HDD AUTO DETECTION
CHIPSET FEATURES SETUP	SAVE & EXIT SETUP
POWER MANAGEMENT SETUP	EXIT WITHOUT SAVING
INTEGRATED PERIPHERALS	
PNP/PCI CONFIGURATION	
LOAD SETUP DEFAULTS	
ESC : Quit	<input type="checkbox"/> <input type="checkbox"/> <input type="checkbox"/> <input type="checkbox"/> : Select Item
F10 : Save & Exit Setup	(Shift)F2 : Change Color
Time, Date, Hard Disk Type ...	

The password entry in this field will be used to check the authority when power-on. Whenever there is the password stored in this fields, the correct password will be requested so that the PC system will continue to load the operation system.

You can enter up to eight alphanumeric characters here. When you have typed in the password and pressed the “Enter” key, you will be asked to reconfirm your password again to complete password setup. If you press the “Enter” key twice without any alphanumeric character entered, the PASSWORD will be disabled.

4.12 IDE HDD AUTO DETECTION

ROM PCI / ISA BIOS (2A6ILP8A)
CMOS SETUP UTILITY
AWARD SOFTWARE, INC.

STANDARD CMOS SETUP	PASSWORD SETTING
BIOS FEATURES SETUP	IDE HDD AUTO DETECTION
CHIPSET FEATURES SETUP	SAVE & EXIT SETUP
POWER MANAGEMENT SETUP	EXIT WITHOUT SAVING
INTEGRATED PERIPHERALS	
PNP/PCI CONFIGURATION	
LOAD SETUP DEFAULTS	
ESC : Quit	<input type="checkbox"/> <input type="checkbox"/> <input type="checkbox"/> <input type="checkbox"/> : Select Item
F10 : Save & Exit Setup	(Shift)F2 : Change Color
	Time, Date, Hard Disk Type ...

In order to make the IDE hard disk known to the system, you need to tell the system what kind of hard disk is connected to the mainboard by giving a set of hard disk parameters. Sometimes it is not easy for users to find the proper parameters for their IDE hard disk drive. In order to help users to find the parameters, the system BIOS provides a convent way – the auto detection of IDE hard disk drive.

To run the auto detection program is extremely easy. Move the selection bar to “IDE HDD AUTO DETECTION” and then press “Enter”, the system BIOS take over the job and try to detect the type of IDE hard disk. If it succeeds, you will see a list of hard disk with its related parameters. You may press on the “Y” key (or select one of the hard disk type listed on the screen). The system BIOS will transfer the parameters to the corresponding fields in the STANDARD CMOS SETUP menu and you have completed the IDE hard disk setup.

4.13 SAVE & EXIT SETUP

ROM PCI/ISA BIOS (2A6ILP8A)
 CMOS SETUP UTILITY
 AWARD SOFTWARE, INC.

STANDARD CMOS SETUP	PASSWORD SETTING
BIOS FEATURES SETUP	IDE HDD AUTO DETECTION
CHIPSET FEATURES SETUP	SAVE & EXIT SETUP
POWER MANAGEMENT SETUP	EXIT WITHOUT SAVING
INTEGRATED PERIPHERALS	
PNP/PCI CONFIGURATION	
LOAD SETUP DEFAULTS	
ESC : Quit	<input type="checkbox"/> <input type="checkbox"/> <input type="checkbox"/> <input type="checkbox"/> : Select Item
F10 : Save & Exit Setup	(Shift)F2 : Change Color
	Time, Date, Hard Disk Type ...

This option will save all setup value to CMOS memory and then exit the SETUP routine. Move the selection bar to "SAVE & EXIT SETUP" and then press the "Enter" key. Confirm with the "Y" and "Enter" keys to the screen prompt and the setup information will be stored in the CMOS memory. The setup program will be terminated and the system will start to reboot.

