

MORE THAN JUST A  
MAINBOARD

# The AZZA P4X Mainboard Series

- [Cover](#) [Click Here](#)
- [Table Of Contents](#) [Click Here](#)
- [Introduction](#) [Click Here](#)
- [Hardware Installation](#) [Click Here](#)
- [BIOS Management](#) [Click Here](#)



*Create High Quality  
Service and Technology*



# P4X Mainboard Series

SOCKET 478 DDR ATX Mainboard

P4X2-AV  
P4XA-AV  
P4XA-BV

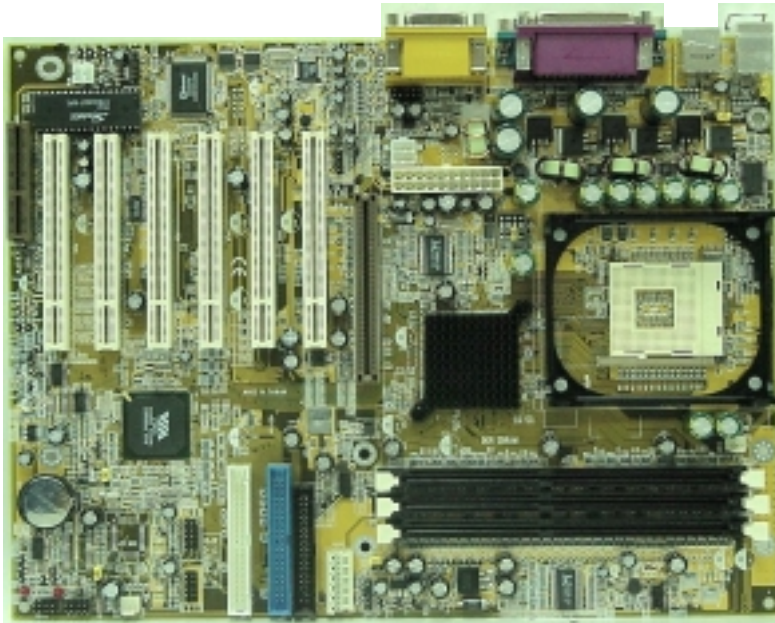

Version 1.x  
UM-P4X-2AABV-E1  
Rev 1.0V  
Creation Date: 22 November 2001



## User's Notice



### Copyright

This publication contains information that is protected by copyright. No part of it may be reproduced in any form or by any means or used to make any transformation adaptation without prior written permission from the copyright holders. This publication is provided for informational purposes only. The manufacturer makes no representations or warranties with respect to the contents or use of this manual and specifically disclaims any express or implied warranties of merchantability or fitness for any particular purpose. The user will assume the entire risk of the use or the results of the use of this document. The manufacturer reserves the right to revise this publication and make changes to its contents at any time, without prior notice.

2001. All Rights Reserved.

### Trademarks

Microsoft®, MS-DOS®, Windows™, Windows® 95 and Windows® 98 are registered trademarks of Microsoft Corporation. Intel® Pentium™ 4 is a registered trademark of Intel Corporation. Award is the registered trademark of Award Software, Inc. Other trademarks and registered trademarks of products appearing in this publication are the properties of their respective holders.

### Package Checklist

This package contains the following items:

- Mainboard
- Users manual
- One IDE cable
- One 34-pin floppy disk drive cable
- One Driver Utility CD

If any of these items are damaged or missing, please contact your dealer or sales representative for assistance.

### Technical Support

If you require additional information or assistance during installation please contact your dealer. Your dealer will be able to provide the latest information.



# Table of Contents



## Chapter 1:- Introduction *Page 5*

<b>1.1. Mainboard Layout .....</b>	<b>5</b>
<b>1.2. Mainboard Overview .....</b>	<b>6</b>
1.2.1. Mainboard Series .....	6
1.2.2. Mainboard Dimensions .....	6
1.2.3. Environmental Limitations.....	6
<b>1.3. Features and Specifications .....</b>	<b>7</b>
<b>1.4. System Health Monitor Functions .....</b>	<b>9</b>
<b>1.5. System Intelligence .....</b>	<b>10</b>

## Chapter 2:- Hardware Installation *Page 11*

<b>2.1. Installation Checklist .....</b>	<b>11</b>
<b>2.2. Installation Steps.....</b>	<b>12</b>
<b>2.3. Expansion Cards, Connectors and Jumpers.....</b>	<b>13</b>
<b>2.4. CPU, Memory and Expansion Slots.....</b>	<b>14</b>
2.4.1. Installation of the CPU.....	14
2.4.2. Memory Modules.....	14
2.4.3. PCI Slots .....	15
2.4.4. AGP (Accelerated Graphics Port) Slot.....	15
2.4.5. CNR (Communications Network Riser) Slot .....	16
<b>2.5. Internal Connectors .....</b>	<b>16</b>
2.5.1. Floppy Disk Drive (FDC) .....	16
2.5.2. Primary and Secondary IDE Connectors.....	16
2.5.3. Standard Infrared Connector .....	17
2.5.4. CPU and Chassis Fan Connectors .....	17
2.5.5. ATX Power Supply Connectors .....	17
2.5.6. WOL (Wake-On-LAN) and WOM (Wake-On-Modem) Connectors .....	18
2.5.7. CD Audio In Connector .....	19
2.5.8. USB 3, USB 4, USB 5 and USB 6 Connectors .....	19
2.5.9. SMB Connector .....	20
<b>2.6. System Panel Buttons and LED Connectors .....</b>	<b>20</b>
2.6.1. PW: Power On/Off and External Suspend Switch Connector .....	20
2.6.2. Standby LED Connector .....	21
2.6.3. IDE HDD LED Connector .....	21
2.6.4. Reset Button Connector .....	21



# Table of Contents



<b>2.7. Speaker and Power LED Connector</b> .....	<b>21</b>
2.7.1. Speaker Connector .....	21
2.7.2. Front Panel Power LED Connector .....	21
<b>2.8. External Connectors</b> .....	<b>22</b>
2.8.1. PS/2 Keyboard Connector .....	22
2.8.2. PS/2 Mouse Connector .....	22
2.8.3. COM 1 and COM 2 Connectors .....	22
2.8.4. Parallel Port Connector .....	22
2.8.5. USB 1 and USB 2 Connectors.....	23
2.8.6. Audio Game Port Connector.....	23
<b>2.9. Jumper Settings</b> .....	<b>23</b>
2.9.1. JP1: Keyboard Power .....	23
2.9.2. JP2: USB1 and USB2 Power .....	24
2.9.3. JP4 and JP5: CPU FSB Selection .....	24
2.9.4. JP13: Clear CMOS Memory .....	24

## Chapter 3:- Managing The PC BIOS *Page 25*

<b>3.1. AWARD BIOS CMOS Setup Utility</b> .....	<b>25</b>
<b>3.2. Main Menu</b> .....	<b>25</b>
<b>3.3. Standard CMOS Setup</b> .....	<b>26</b>
<b>3.4. Advanced BIOS Features</b> .....	<b>28</b>
<b>3.5. Advanced Chipset Features</b> .....	<b>31</b>
<b>3.6. Integrated Peripherals</b> .....	<b>34</b>
<b>3.7. Power Management Setup</b> .....	<b>38</b>
<b>3.8. PNP/PCI Configuration</b> .....	<b>41</b>
<b>3.9. PC Health Status</b> .....	<b>42</b>
<b>3.10. Frequency/Voltage Control</b> .....	<b>43</b>
<b>3.11. Load Fail-Safe Defaults</b> .....	<b>44</b>
<b>3.12. Load Optimized Defaults</b> .....	<b>45</b>
<b>3.13. Set Supervisor Password</b> .....	<b>45</b>
<b>3.14. Set User Password</b> .....	<b>46</b>
<b>3.15. SAVE &amp; EXIT SETUP/EXIT WITHOUT SAVING</b> .....	<b>47</b>

## Chapter 1 - Introduction

### 1 Mainboard and PC99 ATX External Connector Layout

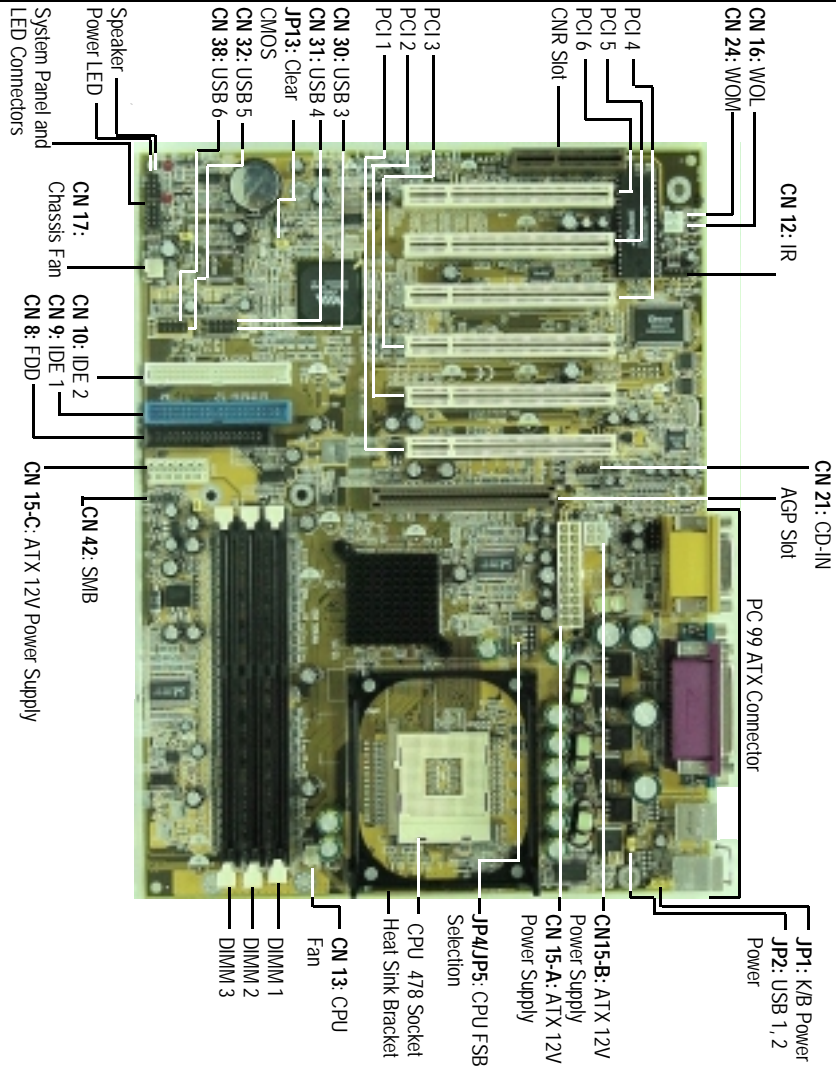



# Introduction



## PC 99 ATX External Connector

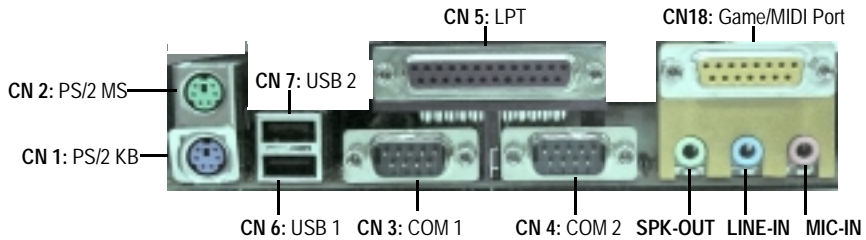

## 1.2. Mainboard Overview

### 1.2.1. Mainboard Series

The mainboards in this manual are all Pentium 4 platforms that use a VIA chipset. This manual describes three different models. They are:

- i) P4X2-AV
- ii) P4XA-AV
- iii) P4XA-BV

The differences between these models are shown in the table below.

Model	P4X2-AV	P4XA-AV	P4XA-BV
Northbridge	P4X266	P4X266A	P4X266A
Southbridge	VT8233	VT8233	VT8233A
USB (1.1)	6	6	4
CNR Slot	Yes	Yes	No
IDE ATA	100	100	133
JP4 & JP5	No	Yes	Yes

### 1.2.2. Mainboard Dimensions

Width & Length: 305 mm x 230 mm

### 1.2.3. Environmental Limitations

Operating Temperature: 10°C to 40°C . (50°F to 104°F)  
 Required Airflow: 50 linear feet per minute across CPU.  
 Storage Temperature: - 40°C to 70°C. (- 40°F to 158°F)  
 Humidity: 0 to 90% non-condensing.  
 Altitude: 0 to 10,000 feet



## 1.3. Features and Specifications

### Processor

Supports Intel® Socket 478 Pentium 4.

### Chipset

**P4X2-AV:** VIA P4X266 + VT8233

**P4XA-AV:** VIA P4X266A + VT8233

**P4XA-BV:** VIA P4X266A + VT8233A

### I/O Chipset

For hardware monitoring: Winbond W83697HF

### CPU Switching Voltage Regulator

Equipped with a switching voltage regulator that automatically detects +1.10V to +1.85V DC power supply.

### System Memory

- 3.0GB DRAMs for registered DDR SDRAM modules.
- 1.5GB DRAMs for unbuffered DDR SDRAM modules.
- Three 184-pin DIMM sockets.
- Supports PC1600 and PC2100 DDR SDRAM

### Expansion Slots

These mainboards are equipped with six dedicated PCI slots, one CNR slot (not available on the **P4XA-BV**) and one 4x AGP slot.

### Onboard Audio Features

Supports Microsoft DirectSound/ DirectSound 3D and AC97 Full Duplex.

### Word Size

- Data Path: 8-bit, 16-bit, 32-bit, 64-bit
- Address Path: 32-bit

### BIOS

- 2Mb Flash ROM
- Award BIOS, Windows 95/98 Plug and Play (PnP) compatible.
- Supports SCSI sequential boot-up.
- Flash EPROM for easy BIOS upgrades.
- Supports DMI 2.0 function



## Introduction



### Desktop Management Interface (DMI)

The mainboard comes with DMI 2.0 built into the BIOS. The DMI utility in the BIOS will automatically record different information about your system configuration and store this information in the DMI pool, which is a part of the system board's Plug and Play BIOS. DMI, along with the appropriately networked software, is designed for easy inventory, maintenance and the simplified troubleshooting of computer systems.

### WOL (Wake-On-LAN) Port

One WOL connector supports Wake-On-LAN functionality.

### WOM (Wake-On-Modem) Port (optional)

One WOM connector supports Wake-On-Modem functionality.

### USB Ports

USB allows data exchange between your computer and a wide range of simultaneously accessible external Plug and Play peripherals. The **P4X2-AV** and **P4XA-AV** models are equipped with **six** (version 1.1) USB connectors. The **P4XA-BV** model is equipped with **four** (version 1.1) USB connectors. USB 1 and USB 2 are external connectors. They can be found on the PC 99 ATX connector. The other USB connectors are internal connectors and can be used to connect other USB devices. (Cables for the internal connectors are sold separately).

**Please note that the internal USB connectors are non-standard. When you purchase the cable please ensure that the connector on one side of the cable is compatible with the internal USB connector and the connector on the other side of the cable is a standard USB connector.**

### Connectors

- Two IDE connectors.
- One floppy drive interface supports up to two 2.88MB floppy drives.
- One 20-pin ATX 12V power supply connector.
- One 2x2 ATX 12V power supply connector.
- One 1x6 ATX 12V power supply connector.
- CPU and chassis fan connectors.
- One CD audio-in connector.
- One system management bus (SMB) connector.



## Introduction



### ATX Double Deck Ports (PC 99 color-coded connectors)

- Two USB ports.
- Two external DB-9 serial port connectors: **COM 1** and **COM 2** (UART).
- One SPP/ECP/EPP DB-25 parallel port.
- One mini-DIN-6 PS/2 mouse port.
- One mini-DIN-6 PS/2 keyboard port.
- One game/MIDI port.
- Three audio jacks: speak-out, line-in and mic-in.

### PCI Bus Master IDE Controller

- Two PCI IDE interfaces support up to four IDE devices.
- The **P4X2-AV** and **P4XA-AV** models support ATA/33, ATA/66 and ATA/100 hard drives.
- The **P4XA-BV** model support ATA/33, ATA/66, ATA/100 and ATA/133 hard drives.
- PIO Mode 3 and Mode 4 Enhanced IDE (data transfer rate up to 16.6MB/sec.).
- Bus mastering reduces CPU utilization during disk transfer.
- Supports ATAPI CD-ROM, LS-120 and ZIP.

### IrDA Interface (Optional)

The mainboard is equipped with an IrDA connector for wireless connectivity between your computer and peripheral devices. It supports peripheral devices that meet the HPSIR or ASKIR standard.

## 1.4. System Health Monitor Functions

The mainboard is capable of monitoring the following health conditions of your system:

1. Processor temperature. It has an overheat alarm.
2. VCORE/3.3V/5V/12V/-12V voltages and failure alarm.
3. Processor and chassis fan speeds. It has a failure alarm for these fans.
4. Read back capability that displays temperature, voltage and fan speed.

**Only use this utility in Windows ® 95 or Windows ® 98 operating systems.**

### The Hardware Monitoring System Utility

These mainboards comes with the Hardware Monitoring System utility contained on the CD. It is capable of monitoring the system's hardware conditions such as the temperature of the processor, voltage, and the speed of both the CPU and chassis fans. You are allowed to manually set a range to the items being monitored. If the values are over or under the set range a warning message will automatically pop up. We recommend that you use the Default Settings, which are the ideal settings that will maintain the system in a good working condition.



## 1.5. System Intelligence

### Dual Function Power Button

Depending on the setting in the Soft-Off By Power-Button field of the Power Management Setup, this switch allows the system to enter the Soft-Off or Suspend mode.

### External Modem Ring-on (optional)

The Modem Ring-on feature allows the system that is in the Suspend mode or Soft Power Off mode to wake-up/power-on to respond to incoming calls. This feature supports the external modem only.

### RTC Timer to Power-on the System

The RTC installed on the system board allows your system to automatically power-on at a set date and time.

### Wake-On-LAN Ready

The Wake-On-LAN function allows the network to remotely wake up a Soft Power Down (Soft-Off) PC. Your LAN card must support the remote wakeup function. The 5V SB power source of your power supply must be at least 720mA.

### ACPI Ready

The mainboard is designed to meet the ACPI (Advanced Configuration and Power Interface) specification. ACPI has energy saving features that support OS Direct Power Management (OSPM) for round the clock PC operation.



## Chapter 2 - Hardware Installation

### 2.1. Installation Checklist

The following is a checklist of all the expansion slots, jumpers and connectors that should be configured on your mainboard before you can run your pc.

<b>Installation Checklist</b>		
<b>Expansion Slots and Sockets</b>		
<b>CPU Slot</b>	Socket 478 CPU Slot which supports <b>Pentium 4</b>	
<b>DIMM Slots</b>	Three 184 pin slots that supports 3 GB DDR SDRAM.	
<b>PCI Slots</b>	Six 32 bit PCI Slots.	
<b>CNR Slot</b>	One Communications Network Riser Slot (Not available for <b>P4XA-BV</b> )	
<b>AGP Slot</b>	One Accelerated Graphics Port Slot	
<b>Internal Connectors</b>		
<b>CN8</b>	Floppy Disk Drive	<b>FDC</b>
<b>CN9</b>	Primary IDE	<b>IDE1</b>
<b>CN10</b>	Secondary IDE	<b>IDE2</b>
<b>CN12</b>	Infrared	<b>IR</b> (optional)
<b>CN13</b>	CPU Fan	<b>CPU Fan</b>
<b>CN15-A</b>	ATX 12V Power Supply	<b>ATX</b>
<b>CN15-B</b>	ATX 12V Power Supply	<b>ATX12V</b>
<b>CN15-C</b>	ATX 12V Power Supply	<b>AUX3.3V</b>
<b>CN16</b>	Wake On Lan	<b>WOL</b>
<b>CN17</b>	Chassis Fan	<b>Chassis Fan</b>
<b>CN21</b>	CD-In without housing	<b>CD-In</b>
<b>CN24</b>	Wake On Modem	<b>WOM</b> (optional)
<b>CN30</b>	Universal Serial Bus 3	<b>USB3</b>
<b>CN31</b>	Universal Serial Bus 4	<b>USB4</b>
<b>CN32</b>	Universal Serial Bus 5	<b>USB5</b> (only for <b>P4X2-AV</b> and <b>P4XA-AV</b> )
<b>CN38</b>	Universal Serial Bus 6	<b>USB6</b> (only for <b>P4X2-AV</b> and <b>P4XA-AV</b> )
<b>CN42</b>	System Management Bus	<b>SMB</b> (optional)
<b>External Connectors</b>		
<b>CN1</b>	PS/2 Keyboard Connector	<b>PS/2 KB</b>
<b>CN2</b>	PS/2 Mouse Connector	<b>PS/2 MS</b>
<b>CN3</b>	Serial Port 1	<b>COM1</b>
<b>CN4</b>	Serial Port 2	<b>COM2</b>
<b>CN5</b>	Parallel Port	<b>LPT</b>
<b>CN6</b>	Universal Serial Bus 1	<b>USB1</b>
<b>CN7</b>	Universal Serial Bus 2	<b>USB2</b>
<b>CN18</b>	Game/Audio Port	<b>Audio/Game</b>
<b>The AZZA P4X MAINBOARD SERIES</b>		<b>Page 11</b>



# Hardware Installation



## Installation Checklist (Continued)

### System Panel Buttons and LED Connectors

<b>PW</b>	Power On/Off and Suspend Switch Connector.
<b>SSL</b>	Standby LED Connector
<b>HL</b>	HDD LED Connector
<b>RS</b>	Reset Button Connector

### Speaker and Power LED Connector

<b>PWR-LED</b>	Power LED
<b>SPK</b>	Speaker Connector

### Jumpers

<b>JP1</b>	Keyboard Power
<b>JP2</b>	USB 1 and 2 Power
<b>JP4/JP5</b>	CPU FSB Selection
<b>JP13</b>	Clear CMOS

**A Diagram of the Expansion Slots, Jumpers and Connectors can be seen on the following page**

## 2.2. Installation Steps

- You need to complete the following installation steps before you can use your PC.
- Check and Set the Mainboard Settings.
- Install the Central Processing Unit (CPU).
- Install the Memory Modules.
- Install the Expansion Cards.
- Connect the Ribbon Cables, Panel Wires and the Power Supply.
- Setup the system BIOS

**Before you start** installing your mainboard we strongly recommend that you use a grounded anti-static mat. We further recommend that you attach an anti-static wristband, which is grounded at the same location as the mat, to your wrist.

**Only use an ATX 12V Power Supply.**

## 2.3. Expansion Cards, Connectors and Jumpers

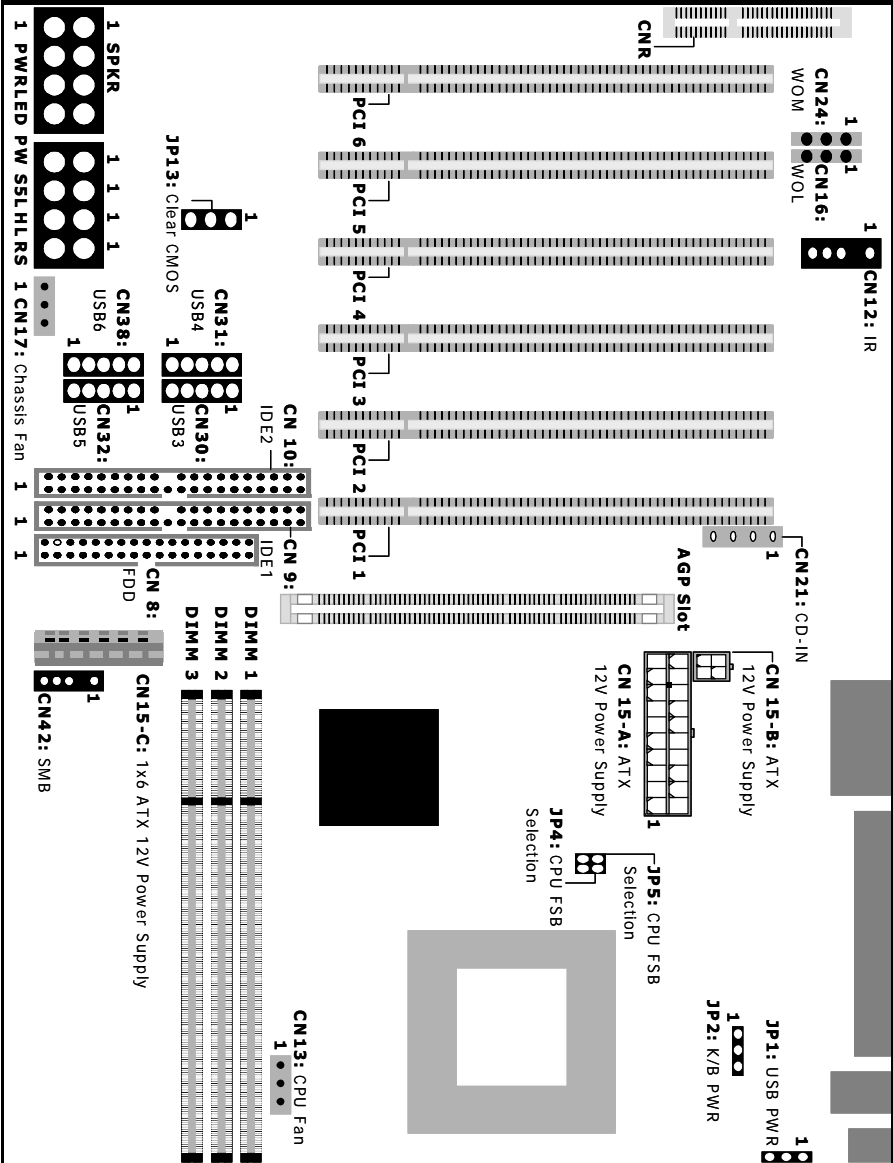

## 2.4. CPU, Memory and Expansion Slots

### 2.4.1. Installation of the CPU

To install your processor, please complete the following set of instructions

1. Locate a small dot marked on the top of the CPU. This mark indicates Pin 1 of the CPU.
2. Locate Pin 1 for the Socket on the mainboard.
3. There is a lever on the side of the socket. First push this lever sideways and then lift it to a 90-degree angle.
4. Insert the CPU into the Socket. Please make sure that Pin 1 for the CPU is inserted into Pin 1 of the Socket.
5. When the CPU is installed correctly push the lever back into place.
6. **Install a proper heat sink with cooling fan** for proper heat dissipation. Failing to install a heat sink with cooling fan may cause overheating which will burnout your CPU and damage your mainboard. The heat sink with cooling fan should be installed on the retention mechanism that is provided. This retention mechanism is designed to hold the bigger Heat Sink that is required for the Pentium 4 CPU.

#### Heat Sink and Retention Mechanism

You must use an Intel approved Heat Sink. This CPU operates at a very high frequency and therefore heats up very quickly. (A normal heat sink will not be adequate to cool the CPU and the CPU will burn-out.) These heat sinks are very heavy. A retention mechanism for the Heat Sink has been provided with the mainboard.

### 2.4.2. Memory Modules

These mainboards all have three 184-pin DDR SDRAM slots. If registered DDR SDRAM modules are used then they can support a maximum of 3 GB DRAM. If unbuffered DDR SDRAM modules are used they can support a maximum of 1.5 GB DRAM

The DDR SDRAM slots are located on the right hand side of the board. To install the DIMM's into these slots, make sure the white lever at each side of the slot has been pulled down to an angle of approximately 45°. Make sure that the DIMM is in the correct orientation. Place the DIMM on the slot and push down firmly. The white levers will come back up and lock the module in place.

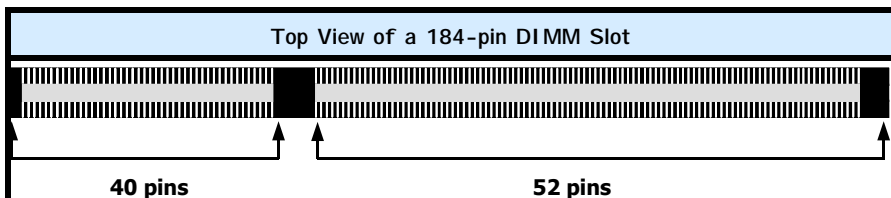



**Important: The DIMM's can only be fitted into the slots in one orientation. Make sure that the DIMM's are in the correct orientation and the pins are correctly aligned before you insert them.**

### **NOTE: "Out Of Memory" Error Message**

If you have installed more than 512 MB of RAM and are running Microsoft Windows Millennium Edition, Windows 98 Second Edition, Windows 98 or Windows 95 you may experience memory problems. Two symptoms of these problems are being unable to run an MS-DOS session while you are running Windows or the computer may stop responding while Windows is starting.

There are three possible solutions to this problem:

- 1) Reduce the amount of memory Vcache uses to 512 MB or less by altering the MaxFileCache setting in the System.ini file.
- 2) Use the System Configuration Utility to reduce the amount of memory Windows uses to 512 MB or less.
- 3) Reduce the memory installed on your computer to 512 MB or less.

This problem can also occur if you are using an Advanced Graphic Port (AGP) video adapter.

### 2.4.3. PCI Slots

These boards come with six PCI slots. They are located on the left hand side of the board. Both PCI and PCI expansion cards may require IRQ's. This mainboard complies with Plug and Play (PnP) specifications. Whenever a PnP compliant card is added the system will automatically be configured and the IRQ's will be assigned automatically.

When you are inserting your PCI card make sure that the pins are correctly aligned. When the pins are properly aligned with the hole's in the slot, push down gently.

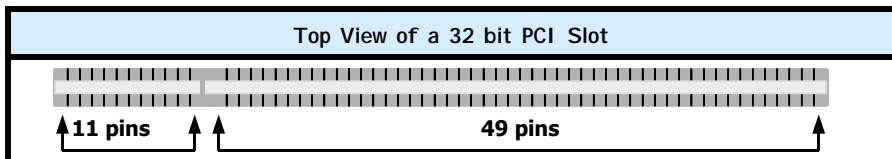

### 2.4.4. AGP (Accelerated Graphics Port) Slot

AGP is a dedicated bus slot. It operates at 66 MHz and transfers data at a rate up to 1066 MB/s. This allows 3D applications to run more smoothly. The P4X2-A mainboards each come with one AGP slot. This slot is able to support 1x, 2x and 4x AGP cards.

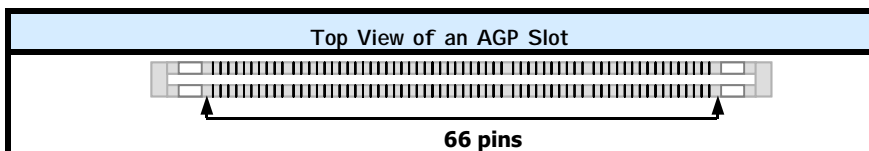



## 2.4.5. CNR Slot (optional for P4XA-BV)

These slots integrate audio, modem and networking on the same card. CNR specifications support the Audio Codec 97 (AC 97) interface, LAN interfaces, USB interfaces and System Management Bus (SMB) interfaces (used specifically to provide Plug and Play functionality).

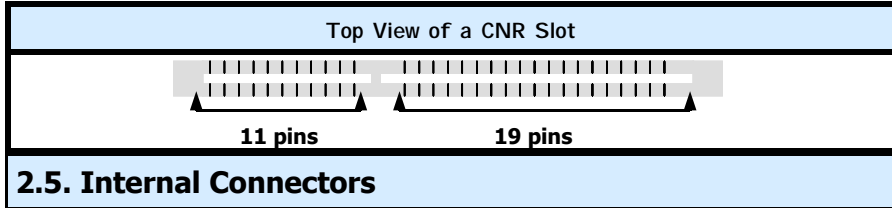

## 2.5. Internal Connectors

### 2.5.1. Floppy Disk Drive (FDC)

Connector: CN 8  
Type: 34 pin block

The FDD connector can support two Floppy drives. It is located at the front of the mainboard. To connect, use the ribbon-cable that has been provided. **Make sure** that the red strip is connected to **PIN 1** of the connector.

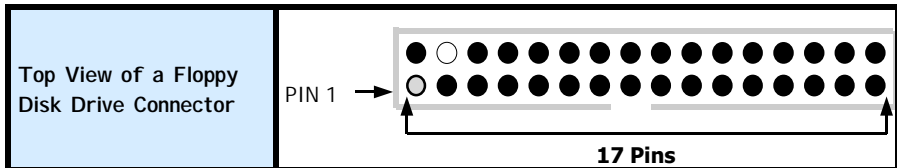

### 2.5.2. Primary and Secondary IDE connectors

Connector: CN 9 (primary)/ CN 10 (secondary)  
Type: 40 pin blocks

These three mainboards all have two IDE connectors: a primary and secondary. Each IDE connector can support two IDE drives. These mainboards can therefore support up to four IDE devices each. If you install two hard drives, you need to configure the second drive to **slave** mode in the BIOS setup. Please refer to your hard drive manual for the appropriate jumper settings.

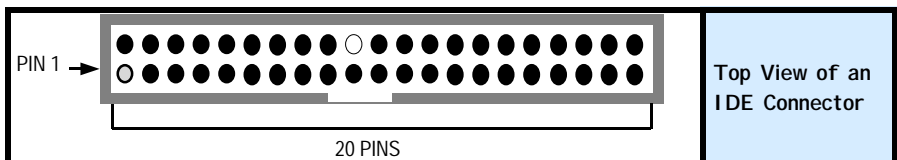



## Hardware Installation



### 2.5.3. Standard Infrared Connector (Optional)

Connector: CN 12  
 Type: 5 pin

The SIR connector supports an optional wireless transmitting and receiving module. You must configure UART 2 to select whether UART 2 is directed for use with COM 2 or IrDA.

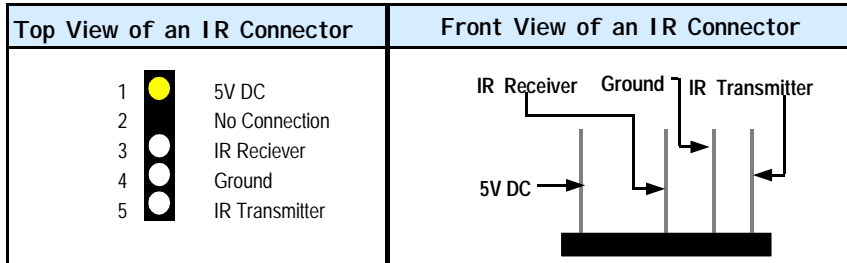

### 2.5.4. CPU Fan and Chassis Fan Connector

Connector: CN 13 (CPU Fan 1)/CN 17 (Chassis Fan)  
 Type: 3 pin

The cooling fans must be connected to their respective power connectors.

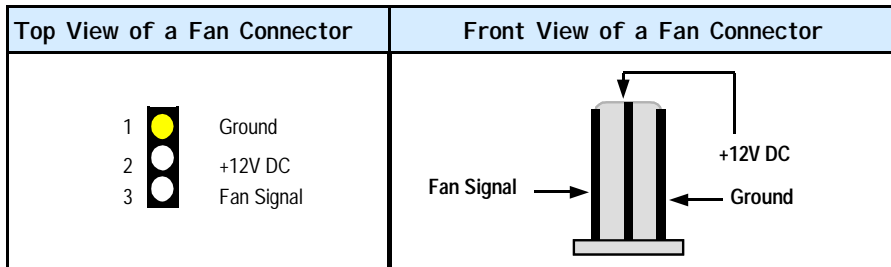

### 2.5.5. ATX12V Power Supply Connectors

Connector: CN 15-A/ CN15-B/ CN15-C  
 Type: 20 pin block/2x2 12V/1x6

The mainboards in this series all come with three onboard power supply connectors labeled from CN15-A to CN15-C. CN15-A and the CN15-B are regular ATX power supply connectors that have been used on all recent motherboards. The CN15-C power connector is for a +3.3V and +5V power supply. These increased power supplies are necessary to provide extra power for the slot. The ATX 12V power supplies are all downward compatible with standard ATX power supplies.



# Hardware Installation

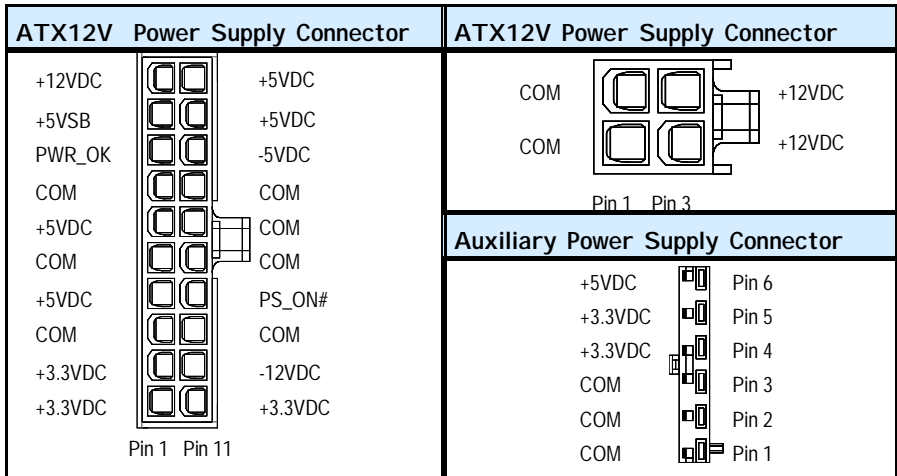

## 2.5.6. WOL (Wake On LAN) and WOM (Wake On Modem) Connectors

**Connector:** CN 16 (WOL)/CN 24 (WOM)  
**Type:** 3 pin

**Note:** The **WOM** Connector (**CN24**) is optional

The WOL connector must be connected to a LAN card that has Wake-On-LAN (WOL) output. This connector powers up the system when a wakeup packet or signal is received through the LAN card.

The WOM connector must be connected to a Modem that has Wake-On-Modem (WOM) output. This connector powers up the system when a wakeup packet or signal is received from the Modem.

In order to use the WOL LAN card or the modem to trigger the power on the PC system, the switching power supply must have the ability to provide a driving current of at least 720 mA and be connected to a "5V standby" voltage.

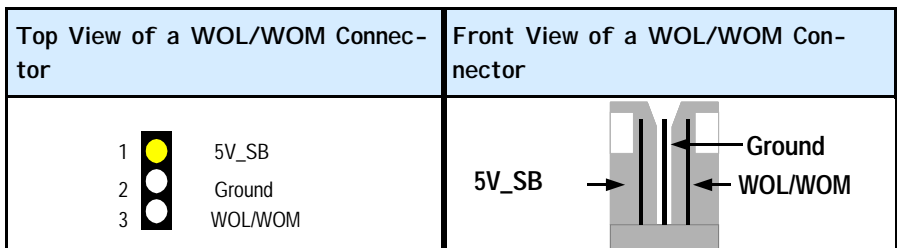

## 2.5.7. CD Audio-in Connector

**Connector:** CN 21  
**Type:** 4 pin un-housed

This mainboard has one CD Audio-in connectors. This connector is used to connect the CD ROM audio out.

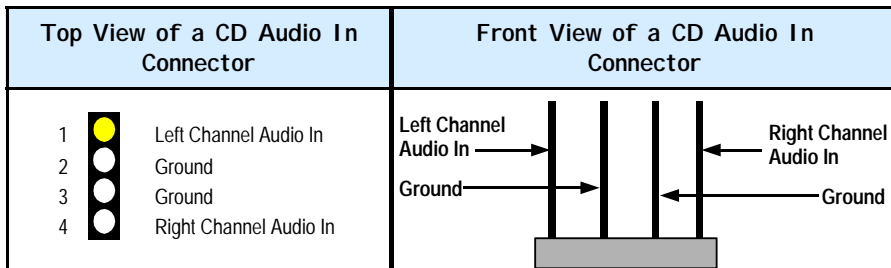

## 2.5.8. USB 3, USB 4, USB 5 and USB 6 connectors

**Connector:** CN 30 (USB 3)/CN 31 (USB 4)/CN 32 (USB 5)/CN 38 (USB 6)  
**Type:** 5 pin / 5 pin/ 5 pin/ 5 pin

You already have two USB ports available, USB 1 and 2 (see external connectors). The internal USB connectors allow you to add on an optional kit to expand the total number of USB ports available. The **P4X2-AV** and **P4XA-AV** have four internal USB connectors (**CN30**, **CN31**, **CN32** and **CN38**). This enables you to use an extra 4 USB devices. The **P4XA-BV** has two internal USB connectors (**CN30** and **CN31**). This enables you to use an extra two USB devices. Cable for these additional connectors needs to be purchased separately.

**Note:** These are not the standard USB connectors you find on the ATX PC99 connector. To connect USB devices you need to use an expansion cable (purchased separately) that ends in a standard USB connector. Ask your retailer for more details.

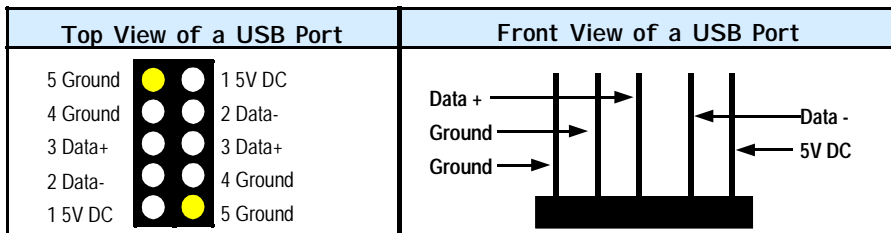



## 2.5.9. SMB (System Management Bus) Connector (optional)

Connector: CN 42

Type: 4 pin

The SMB is a 2-wire specification which allows for communications between an external UPS or other power devices and a computer. Each of these mainboards has a SMB connector onboard, which can be connected to other SMB devices .

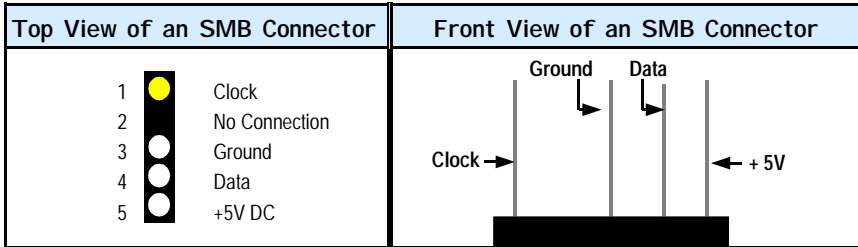

## 2.6. System Panel Buttons and LED Connectors

The following System Panel Buttons and LED Connectors can be found at the front of the mainboard on the left hand side.

**PW** = Power On/Off and Suspend Switch Connector  
**S5L** = Standby LED Connector  
**HL** = HDD LED Connector  
**RS** = Reset Button Connector

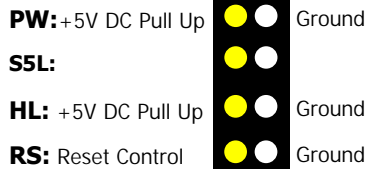

Top View of the System Panel and LED Connectors

### 2.6.1 PW: Power On/Off and External Suspend Switch Connector

The Power On/Off connector has two functions. It can be the Power Switch or Suspend Switch of your PC system. You can either choose "Delay 4 Sec or Instant OFF" (Please refer to the Award BIOS setup instructions in Chapter 3).

**Option 1:** If you choose "Delay 4 Sec." In the BIOS CMOS Setup, the function of "PW" will be:

- A. When the system power is "OFF", press this switch, the system will power on.
- B. When system power is "ON", you can select two different modes: -

**Mode 1:** Press and hold the Power ON button for less than 4 seconds and then release it. The system will be turned into Suspend mode (turned into the GREEN mode) When the system is in the Suspend mode: -

- Press the Power on button (less than 4 seconds), the system will return to Full ON mode.



- Press and hold the Power On Button for more than 4 seconds, the system will be powered off.

**Mode 2:** Press and hold the Power ON button for more than 4 seconds, the system will be completely powered off.

**Option 2:** If you choose "Instant OFF." In the BIOS CMOS Setup, the power switch will operate like a normal ON / OFF Power button.

### 2.6.2. S5 LED Connector

When the AC power is "ON" the mainboard will always have a standby voltage of +5V and the S5 LED will be on. If this LED is off it means that the AC power is "OFF" or has been disconnected or Full on.

### 2.6.3. IDE HDD LED Connector

Any read and write activity by the HDD will turn this LED on.

### 2.6.4. Reset Button Connector

If you connect this connector, you will be able to reset you computer by pressing the reset button at the front of the chassis.

## 2.7. Speaker and Power LED Connectors

### 2.7.1. Speaker Connector

Connect your chassis speaker to this five pin connector. It allows you to hear systems beeps and warnings sound.

PIN 1 →

### 2.7.2. Front Panel Power LED

The chassis Power LED connector can be connected to the four pin connector. When you turn your system on, this LED will also be turned on.

PIN 1 →

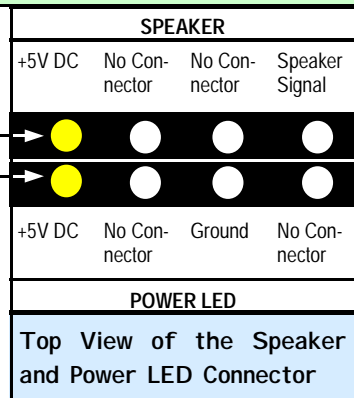

## 2.8. External Connectors

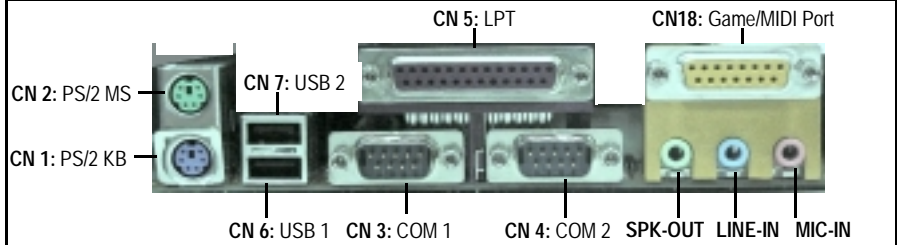

### 2.8.1. PS/2 Keyboard connector.

**Connector:** CN 1  
**Type:** 6 pin female

This connector only supports a PS/2 keyboard plug. If you have a standard AT size (large DIN) keyboard plug, you need to use a mini DIN adapter.

### 2.8.2. PS/2 Mouse connector.

**Connector:** CN 2  
**Type:** 6 pin female.

This connector only supports a PS/2 mouse plug. If a PS/2 mouse is detected then IRQ 12 will be directed to CN 2.

### 2.8.3. Serial Port 1 (COM 1) and Serial Port 2 (COM 2)

**Connector:** CN 3 (COM 1)/ CN 4 (COM 2)  
**Type:** 9 pin male/9 pin male

One serial port is available for a mouse and other serial devices. (I/O addresses used are 3F8H/2F8H/3E8H/2E8H and IRQ3/IRQ4, selected by CMOS setup.)

### 2.8.4. Parallel Port Connector

**Connector:** CN 5  
**Type:** 25 pin female.

This parallel port is used by printers which support the SPP, EPP and ECP modes. IRQ7 or IRQ5 can be selected. The ECP mode will use either DMA 3 or DMA 1 (which can be selected by the BIOS setup program).



## 2.8.5. Universal Serial Bus (USB) Port 1 & 2

**Connector:** CN 6 (USB 1)/ CN 7 (USB 2)  
**Type:** 4 pin female

Two USB ports are available for connecting USB devices. The mainboard is also equipped with an expansion connector that supports four additional USB external connectors. (The USB cable is not included with the mainboard).

## 2.8.6. Audio/Game Port Connector

**Connector:** CN 18  
**Type:** 15 pin female

The Game/MIDI port connector is a dual purpose connector. It can either be used to connect a joystick to the computer for game participation, or it can be used to attach an external MIDI device. All these motherboards have 3D audio interfaces onboard.

## 2.9. Jumper Settings

Jumpers are built on the mainboard to allow the user flexibility to configure the mainboard settings to meet their specific requirements. These mainboards have both two pin and three pin jumpers.

If a two pin jumper has a jumper cap on it we say that it is short. If there is no Jumper cap we say it is open. On a three pin jumper if a jumper cap is inserted on pins 1 and 2 we say **PIN 1** and **PIN 2** are **SHORT**. When the jumper cap is inserted on pin 2 and 3, we say **PIN 2** and **PIN 3** are **SHORT** (see the diagrams below).

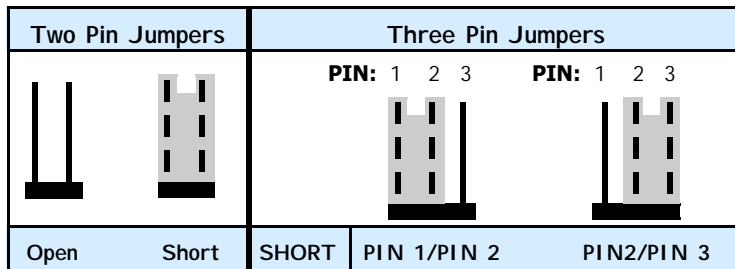

### 2.9.1. JP1: Keyboard Power

**Type:** 3 pin  
**Default:** Pin 1 and Pin 2 Short

Some keyboards may not follow standard specifications. If you find you are having problems with your keyboard, change the settings on JP 1. This might help you to solve the problem.



## 2.9.2. JP2: USB 1 and USB 2 power

**Type:** 3 pin  
**Default:** Pin 1 and Pin 2 Short

This jumper allows you to select the voltage that is supplied to USB 1 and USB 2. You have two choices: 5 V (pin 1 and pin 2 short) or standby 5 V (pin 2 and pin 3 short). Some USB devices may not follow the standard USB power specifications. If you are using such a device it may unstable. If you do experience problems try to change the setting on JP 2. This might help solve this problem.

## 2.9.3. JP4 and JP5: CPU FSB Clock (optional)

**Type:** (JP4) 2 pin/(JP5) 2 pin  
**Default:** (JP4) short/ (JP5) open

The Default settings for these jumpers must be kept since they force the FSB to be 400MHz. Future mainboards based on updated VIA P4X266A chipsets will be able to support a higher FSB and these jumpers can then be used to select a desired FSB. Therefore Please retain the current default settings

	JP4	JP5
FSB 400 (100)	Short	Open
Reserved	Open	Short

## 2.9.4. JP13: Clear CMOS

**Type:** 3 pin  
**Default:** Pin 1 and Pin 2 Short

If you have made an improper setting in the BIOS setup and your computer is not functioning, or if you have forgotten your password, you can use this jumper, JP13, to clear the CMOS and to reconfigure your system.

**To clear the CMOS, please follow these instructions:**

1. Turn the system power "OFF" and unplug your computer.
2. Insert the jumper cap on Pin 2 and Pin 3 for 3 ~ 5 seconds.
3. Pull out the jumper cap and replace it on Pin 1 and Pin 2.
4. Turn your PC on and run the BIOS setup program.



## Chapter 3 - Managing the PC BIOS

### 3.1. Award BIOS CMOS Setup Utility

Once you have installed the mainboard you still need to setup the BIOS before you can run your PC. The EEPROM on the mainboard stores the AWARD BIOS CMOS Setup Utility, which allows you to configure your system. When you want to configure or make any changes to the configuration of your system BIOS you must run the BIOS CMOS Setup Utility.

#### GETTING STARTED

Every time you start your computer, the system provides you with an opportunity to run the BIOS CMOS Setup Utility. As soon as you turn on your system, press the <Delete> button to activate the BIOS CMOS Setup Utility.

If your computer finishes the POST (Power-On-Self-Test) the BIOS CMOS Setup Utility will **not be** activated. If your computer completes the POST you need to restart the system to activate the BIOS CMOS Setup Utility. To restart the system, you can either turn the power off, press the reset button on your chassis or press the <Ctrl> + <Alt> + <Delete> button. In all three cases the system will restart and, to activate the BIOS CMOS Setup Utility, you must immediately press the <Delete> button.

### 3.2. Main Menu

Once you have called up the BIOS CMOS Setup Utility, the following screen will appear:

<b>CMOS Setup Utility – Copyright ( C ) 1984 - 2001 Award Software</b>	
<ul style="list-style-type: none"> <li>▶ Standard CMOS Features</li> <li>▶ Advanced BIOS Features</li> <li>▶ Advanced Chipset Features</li> <li>▶ Integrated Peripherals</li> <li>▶ Power Management Setup</li> <li>▶ PNP/PCI Configuration</li> <li>▶ PC Health Status</li> </ul>	<ul style="list-style-type: none"> <li>▶ Frequency/Voltage Control</li> <li>Load Fail-Safe Defaults</li> <li>Load Optimized Defaults</li> <li>Set Supervisor Password</li> <li>Set User Password</li> <li>Save &amp; Exit Setup</li> <li>Exit Without Saving</li> </ul>
Esc : Quit      F9 : Menu in BIOS      ← ↑ ↓ → : Select Item F10 : Save and Exit Setup	
Time, Date, Hard Disk Type ...	

**Note!** BIOS software is continuously updated therefore the BIOS menus and the descriptions that are given in this manual are for reference purposes only.



## Navigation Keys

You will notice a legend bar at the bottom of the main menu. The keys in this legend bar show you how to navigate through the setup menus. The table below lists the control keys with their corresponding functions: -

Control Key	Function
<b>Up Arrow</b>	Moves to the previous item.
<b>Down Arrow</b>	Moves to the next item.
<b>Left Arrow</b>	Moves to the item on the left.
<b>Right Arrow</b>	Moves to the item on the right.
<b>Enter</b>	Selects the desired item.
<b>F1</b>	Displays the help screen for the selected feature.
<b>Esc key</b>	Exits to the previous screen.
<b>PgUp(-)/PgDn(+)</b>	Modifies or changes the content of the highlighted item.
<b>F5</b>	Restores the previous CMOS values to the current page setup. This will not restore the previous values for any other pages.
<b>F7</b>	Loads the SETUP default values from BIOS default table, (only the current page setup will be loaded).
<b>F10</b>	Saves changes to the CMOS and exits the setup.

### 3.3. Standard CMOS Setup (Menu on page 27: [click here](#))

#### Date (mm : dd : yy)

Sets your system to the date that you specify (usually the current date). The format is month, day, and year. Press the right or left arrow key to move to the desired field (month, date, year). Press the PgUp or PgDn key to increment the setting, or type the desired value into the field.

#### Time (hh : mm : ss)

Sets your system to the time you specify (usually the current time). The format is hour, minute, second. The time format is based on the 24-hour military-time clock. For example, 1 p.m. is 13:00:00. Press the right or left arrow key to move to the desired field. Press the PgUp or PgDn key to increment the setting, or type the desired value into the field.

#### IDE Primary / Secondary, Master / Slave

This mainboard supports four IDE Hard Drives. These fields allow you to set your Hard Drive parameters. Move the selection bar to the IDE Hard Drive you want to configure. Press the "ENTER" key. If you select "AUTO" the system BIOS will detect the HDD type automatically.



# Managing The PC BIOS



CMOS Setup Utility - Copyright ( C ) 1984 - 2001 Award Software Standard CMOS Features		
Date (mm : dd : yy) Time (hh : mm : ss)	Wed, Nov 21, 2001 13 : 9 : 16	Item Help
▶ IDE Primary Master ▶ IDE Primary Slave ▶ IDE Secondary Master ▶ IDE Secondary Slave	[QUANTUM FIREBALL PKA] [Pioneer DVD-ROM ATAPI] [None] [None]	Menu Level ▶
Drive A Drive B Floppy 3 mode support	[1.44M 3.5in] [None] [Disabled]	Change the day, month, year and centu- ry
Video Halt On	[EGA/VGA] [All Errors]	
Base Memory Extended Memory Total Memory	640K 392192K 393216K	

## Drive A /B

These mainboards can support up to two floppy disk drives. These two selection fields allow you to select the floppy drives that are installed on your computer. Select the correct specifications for the diskette drive(s) installed on your computer.

Diskette Drive	Type of Disk Drive	Capacity
None	No diskette drive installed	
360K 5.25 in	5-1/4 inch PC-type standard drive	360 KB
1.2M 5.25 in	5-1/4 inch AT-type high-density drive	1.2 MB
720K 3.5 in	3-1/2 inch single-sided drive	720 KB
1.44M 3.5 in	3-1/2 inch double-sided drive	1.44 MB
2.88M 3.5 in	3-1/2 inch double-sided drive	2.88 MB

## Floppy 3 Mode Support

If you have installed a 3.5 inch high capacity floppy disk drive you need to enable this option. If you have not installed one of these drives use the default setting.

## Video

This field selects the type of primary video subsystem that is on your computer. The BIOS CMOS Setup Utility will automatically detect the correct video type.



## Managing The PC BIOS



Monitors	
EGA/VGA	Enhanced Graphics Adapter/Video Graphics Array. For EGA, VGA , SEGA, SVGA or PGA monitor adapters
CGA 40	Color Graphics Adapter power up in 40 column mode
CGA 80	Color Graphics Adapter power up in 80 column mode
MONO	Monochrome adapter includes high resolution monochrome adapters

### Halt On

This field allows you to decide which errors, detected during the Power On Self Test (POST), will halt the system.

### Base Memory / Extended Memory / Total Memory

This field displays the amount of memory detected by the system during boot up. This is a display only field. You cannot make any changes to this field.

**Base Memory:** Indicates the memory installed below the conventional 1MB space.

**Extended Memory:** Indicates the memory installed above the 1MB space.

**Total Memory:** Indicates the total memory installed in the PC system.

## 3.4. Advanced BIOS Settings (Menu on page 29: [click here](#))

### Virus Warning

When you enable the virus warning you will receive a warning message whenever a program (specifically, a virus) attempts to write to the boot sector or the partition table of the hard disk drive. If you receive such a message you should immediately run an anti-virus program. Keep in mind that this feature **only** protects the boot sector and not the entire hard drive.

**NOTE! Many disk diagnostic programs that access the boot sector table can trigger the virus-warning message. If you plan to run such a program, we recommend that you first disable the virus warning.**

### CPU L1 & L2 Cache

This BIOS setting can be used to enable or disable the CPU's L1 (primary) and L2 (secondary) cache.

### CPU L2 Cache ECC Checking

When you select Enabled, the ECC checking will ensure that the data stored on the L2 cache is accurate.



## Managing The PC BIOS



CMOS Setup Utility - Copyright ( C ) 1984 – 2001 Award Software.  
Advanced BIOS Features

Virus Warning	[Disabled]	
CPU L1 & L2 Cache	[Enabled]	
CPU L2 Cache ECC Checking	[Enabled]	
Quick Power On Self Test	[Enabled]	Menu Level ▶
First Boot Device	[Floppy]	Allows you to choose the VIRUS warning feature for IDE Hard disk boot sector protection. If this function is enabled and someone attempts to write data into this area, BIOS will show a warning message on screen and alarm beep.
Second Boot Device	[HDD-0]	
Third Boot Device	[LS120]	
Boot Other Device	[Enabled]	
Swap Floppy Drive	[Disabled]	
Boot Up Floppy Seek	[Enabled]	
Boot Up NumLock Status	[On]	
Typematic Rate Setting	[Disabled]	
X Typematic Rate (Chars/Sec)	6	
X Typematic Delay (Msec)	250	
Security Option	[Setup]	
PS/2 Mouse Function Control	[Enabled]	
OS Select For DRAM > 64 MB	[Non-OS2]	
HDD S.M.A.R.T. Capability	[Disabled]	
Video BIOS Shadow	[Enabled]	
Small Logo (EPA) Show	[Enabled]	

### Quick Power On Self Test

If enabled the amount of time required to run the power-on self-test (POST) will decrease. A quick POST skips certain steps. We recommend that you disable quick POST. It is better to find a problem during POST than to lose data during your work.

### First / Second / Third Boot Device

These fields allow you to decide the boot sequence of your bootable devices such as Floppy Drive, Hard Drive, CD ROM...etc

### Boot Other Device

When this field is enabled you will be able Boot your computer from a another device, not your HDD or FDD.

### Swap Floppy Drive

This field is effective only in systems with two floppy drives. When Enabled is selected physical drive B is assigned to logical drive A, and physical drive A is assigned to logical drive B.



### Boot Up Floppy Seek

When enabled, the BIOS tests (seeks) floppy drives to determine whether they have 40 or 80 tracks. Only 360-KB floppy drives have 40 tracks; drives with 720 KB, 1.2 MB, and 1.44 MB capacity all have 80 tracks. Very few modern PCs have 40-track floppy drives so we therefore recommend that you set this field to Disabled to save time.

### Boot Up NumLock Status

This controls the state of the NumLock key when the system boots. This field is toggled between On or Off. When it is on the numeric keypad generates numbers instead of controlling the cursor operations. When it is off the numeric keypad controls cursor operations and does not generate numbers.

### Typematic Rate Setting

The keyboard controller determines the rate at which the keystrokes from the keyboard are repeated. If you enable this option then the typematic rate and the typematic delay can be selected.

#### Typematic Rate

This is the rate a character will repeat itself on the screen when you hold down a key.

#### Typematic Delay

This is the delay time (Msec) before the repetition of characters starts.

### Security Option

This field allows you to select the "Setup" or "System" security option. It works concurrently with the "Set Supervisor Password" in the main menu.

When the "Setup" option is selected, you will be prompted to enter your "Password" before you can start the BIOS CMOS Setup Utility. When you select "System" option, you will be prompted to enter your password in order to load the Operating System.

#### **TIP: Forgot your password then clear the RTC RAM**

If you happen to forget your password you can use Jumper 13 (JP13) to clear the password by erasing the CMOS Real Time Clock (RTC) Ram. For further details on how to do this please see section 2.9.4 on page 24. ([Click Here](#))

### PS/2 Mouse Function Control

If you have installed a serial pointing device and your system has a PS/2 mouse port you should disable this option.



# Managing The PC BIOS



## OS Select For DRAM > 64MB

Only select OS2 if you are running an OS/2 operating system with a RAM greater than 64 Mb. Otherwise, for all other operating systems, use the default setting "Non-OS2"

## HDD S.M.A.R.T Capability (Using this feature may decrease system performance)

You may "enable" this option if your Hard Drive supports the S.M.A.R.T. technology (Self Monitoring Analysis Reporting Technology) feature. S.M.A.R.T. will monitor and report your Hard Drive health status. Ask your Hard Drive Vendor for further information.

## Video BIOS Shadow

These fields allow you to change the Video BIOS location from ROM to RAM. Information access is faster through RAM than ROM. Therefore when you enable this option you will enhance your system performance.

## 3.5. Advanced Chipset Features

CMOS Setup Utility - Copyright (C) 1984 - 2001 Award Software Advanced Chipset Features		
▶ DRAM Clock/Drive Control	[Press Enter]	Item Help
▶ AGP & P2P Bridge Control	[Press Enter]	Menu Level ▶
▶ CPU & PCI Bus Control	[Press Enter]	
Memory Hole	[Disabled]	
System BIOS Cacheable	[Disabled]	
Video RAM Cacheable	[Disabled]	
Delay Prior to Thermal	[16 min]	

## Dram Clock Drive Control

This field allows you to select the FSB and DRAM frequency.

CMOS Setup Utility - Copyright (C) 1984 - 2001 Award Software DRAM Clock/Drive Control		
Current FSB Frequency	100 MHz	Item Help
Current DRAM Frequency	133 MHz	Menu Level ▶ ▶
DRAM Clock	[By SPD]	
DRAM Timing	[By SPD]	
X SDRAM Cycle Length	2.5	
X Bank Interleave	Disabled	
X Precharge to Active (Trp)	3T	
X Active to Precharge (Tras)	6T	
X Active to CMD (Trcd)	3T	
X DRAM Burst Len	4	
X DRAM Command Rate	[2T Command]	
X CPU Read DRAM Mode	[Medium]	



## Managing The PC BIOS



### ▶ Current FSB Frequency

The setting for this field will be automatically selected by the BIOS.

### ▶ Current Dram Frequency

The setting for this field will be automatically detected by the BIOS. The value that is selected in derived from the RAM clock.

### ▶ DRAM Clock

When you select **By SPD** The following menu will pop up:

100 MHz

133 MHz

By SPD

If you select **100 MHz** the DRAM clock speed will be PC1600 (100 MHz DDR).

If you select **133 MHz** the DRAM clock speed will be PC2100 (133 MHz DDR). If you select **By SPD** the BIOS will automatically detect the actual DRAM Clock.

### ▶ DRAM Timing

This field determines the DRAM read/write timing. The performance parameters of the memory chips (DRAM) you have installed will determine the value in this field. Do not change the value from the factory setting unless you install new memory that has a different performance rating than the original DRAMs.

### ▶ SDRAM Cycle Length

Before SDRAM can execute a read command that it receives, there is a delay time, which is measured in clock cycles (CLK). The lower the delay time the faster the execution of commands will be. It is therefore desirable to minimize this cycle length. Some memory modules are unable to deal with short delay times. We recommend that you set this delay time between 2.5 and 3 CLK's (the default is 2.5). If your system becomes unstable we recommend that you increase the delay time.

### AGP & P2P Bridge Control

CMOS Setup Utility - Copyright (C) 1984 - 2001 Award Software AGP & P2P Bridge Control		
AGP Aperture Size	[128M]	Item Help
AGP Mode	[4X]	Menu Level ▶▶
AGP Driving Control	[Auto]	
X AGP Driving Value	DA	
AGP Fast Write	[Disabled]	
AGP Master 1 WS Write	[Disabled]	
AGP Master 1 WS Read	[Disabled]	



## Managing The PC BIOS



### ▶ AGP Aperture Size

This field selects the size of the Accelerated Graphics Port (AGP) aperture. The aperture is a portion of the PCI memory address range dedicated for graphics memory address space. Host cycles that hit the aperture range are forwarded to the AGP without any translation. The default is 64MB. You may increase this memory when you need to have faster access for 3D graphics applications (e.g. games).

### ▶ AGP Mode

This item allows you to select 1x, 2x or 4x AGP mode.

### ▶ AGP Driving Control

The recommended setting for this field is the default "Auto". If you have an unstable AGP card you may use this field to choose the appropriate settings. If you do need to tune the timing, please consult your AGP Card manual or Vendor.

### ▶ AGP Driving Value

This item allows you to adjust the AGP driving force.

### ▶ AGP Fast Write

Some AGP cards, like G-Force, support AGP fast write. If you have an AGP card that supports this mode you can enable this field. If your AGP card does not support the fast write mode then leave this field "disabled".

### ▶ AGP Master 1 WS Write

When Enabled, writes to the AGP are executed with one-wait states.

### ▶ AGP Master 1 WS Read

When Enabled, reads to the AGP are executed with one-wait states.

## CPU & PCI Bus Control

CMOS Setup Utility - Copyright (C) 1984 - 2001 Award Software CPU & PCI Bus Control		
CPU to PCI Write Buffer	[Enabled]	Item Help
PCI Master 0 WS Write	[Enabled]	Menu Level ▶ ▶
PCI Delay Transaction	[Disabled]	

### ▶ CPU to PCI Write Buffer

When you enable this option writes from the CPU to the PCI bus are buffered so that the CPU will not have to wait until the write is completed before starting another write cycle.

### ▶ PCI Master 0 WS Write

When enabled, writes to the PCI bus are executed with zero wait states.

### ▶ PCI Delay Transaction

The chipset has an embedded 32-bit posted write buffer to support delay transactions cycles. Select Enabled to support compliance with PCI specification version 2.1.



# Managing The PC BIOS



## Memory Hole

You can reserve this area of system memory for ISA adapter ROM. When this area is reserved, it cannot be cached. The user information of peripherals that need to use this area of system memory usually discusses their memory requirements.

## System BIOS Cacheable

Selecting "Enabled" allows caching of the system BIOS ROM. This results system performance. However, if any program writes to this memory area, a system error may occur.

## Video RAM Cacheable

Select Enabled allows caching of the video RAM, resulting in better system performance. However, if any program writes to this memory area, a system error may occur.

## 3.6. Integrated Peripherals

CMOS Setup Utility - Copyright (C) 1984 - 2001 Award Software Integrated Peripherals		
▶ VIA OnChip IDE Device	[Press Enter]	Item Help
▶ VIA OnChip PCI Device	[Press Enter]	Menu Level ▶
▶ SuperIO Device	[Press Enter]	
Init Display First	[PCI Slot]	
OnChip USB Controller	[All Enabled]	
USB Keyboard Support	[Disabled]	
IDE HDD Block Mode	[Enabled]	

## VIA OnChip IDE Device

CMOS Setup Utility - Copyright (C) 1984 - 2001 Award Software VIA OnChip IDE Device		
OnChip IDE Channel0	[Enabled]	Item Help
OnChip IDE Channel1	[Enabled]	Menu Level ▶
IDE Prefetch Mode	[Enabled]	
Primary Master PIO	[Auto]	
Primary Slave PIO	[Auto]	
Secondary MasterPIO	[Auto]	
Secondary Slave PIO	[Auto]	
Primary Master UDMA	[Auto]	
Primary Slave UDMA	[Auto]	
Secondary MasterUDMA	[Auto]	
Secondary Slave UDMA	[Auto]	



## Managing The PC BIOS



### ▶ OnChip IDE Channel 0/1

The chipset contains a PCI IDE interface with support for two IDE channels. To activate the primary IDE interface select Enabled. If you want to disable the onboard IDE 1 and/or 2, then select Disabled and this interface will be deactivated

### ▶ IDE Prefetch Mode

The onboard IDE drive interfaces supports IDE pre-fetching for faster drive access. If you install a primary and/or secondary add-in IDE interface which does not support pre-fetching set this field to Disabled.

### ▶ Primary/Secondary, Master/Slave PIO

The four IDE PIO (Programmed Input/Output) fields let you set a PIO mode (0-4) for each of the four IDE devices that the onboard IDE interface supports. Modes 0 through 4 provide successively increased performance. In Auto mode, the system automatically determines the best mode for each device.

### ▶ Primary/Secondary, Master/Slave UDMA

Ultra DMA/66 implementation is possible only if your IDE hard drive supports it and the operating environment includes a DMA driver (Windows 98 OSR2 or a third-party IDE bus master driver). If your hard drive and your system software both support Ultra DMA/66, select Auto to enable BIOS support.

## VIA OnChip PCI Device

<b>CMOS Setup Utility - Copyright (C) 1984 - 2001 Award Software</b>		
<b>VIA OnChip PCI Device</b>		
<b>VIA-3058 AC97 Audio</b>	<b>[Auto]</b>	<b>Menu Level ▶▶</b>
<b>VIA-3068 MC97 Modem</b>	<b>[Auto]</b>	

### ▶ VIA-3058 AC97 Audio

If you want to enable the on-chip audio capabilities of your system you need use the default setting "Auto". If you install an add on sound card you must disable this field.

### ▶ VIA-3068 MC97 Modem

This chipset can support MC97 Modem. This field allows you to decide whether you want this support or not. If you select "Auto" the BIOS will automatically detect the AC97. If you select "Disabled" the Bios will not detect any support for the AC97 audio/modem.

## SuperIO Device

When you press enter the menu on [page 36 \(click here\)](#) will appear:

### ▶ Onboard FDC Controller

Select Enabled if your system has a floppy disk controller (FDC) installed on the system board and you want to use it. If you install an add-in FDC or the system has no floppy drive, select Disabled in this field.



# Managing The PC BIOS



CMOS Setup Utility - Copyright (C) 1984 - 2001 Award Software  
SuperIO Device

Onboard FDC Controller	[Enabled]	Item Help
Onboard Serial Port 1	[3F8/IRQ4]	Menu Level ▶▶
Onboard Serial Port 2	[2F8/IRQ3]	
UART Mode Select	[Normal]	
X RxD, TxD Active	Hi, Lo	
X IR Transmission Delay	Enabled	
X UR2 Duplex Mode	Half	
X Use IR Pins	IR-Rx2Tx2	
Onboard Parallel Port	[378/IRQ7]	
Parallel Port Mode	[SPP]	
X EPP Mode Select	EPP1.7	
X ECP Mode Use DMA	3	
Game Port Address	[201]	
Midi Port Address	[330]	
Midi Port IRQ	[10]	

### ▶ Onboard Serial Port 1/Port 2

These two selection fields allow you to select the I/O address and corresponding interrupts for the first and second serial ports.

### ▶ UART Mode Select

Your system may offer a variety of infrared modes on the second serial port. The options are Standard, HPSIR or ASKIR.

### ▶ RxD, TxD Active

This field allows you to set the IR reception/transmission polarity as high or low. To determine which polarity is appropriate you must refer to the documentation for the IR peripheral that is being used.

This field is usually found under the Onboard Serial Port 2 option. If you disable the Onboard Serial Port 2 Option then you will probably not be able to configure this field.

### ▶ IR Transmission Delay

This field allows you to "Enable" or "Disable" the IR Transmission Delay.

### ▶ UR2 Duplex Mode

This field appears in an infrared port mode. You have two options: half or full duplex function. The full duplex mode allows bi-directional transmission at a single time where as the half duplex mode only allows transmission in one direction at a time. This setting depends on the nature of your IR peripheral device. Check the IR device's manual to determine the appropriate setting.

### ▶ Use IR Pins

To determine the correct settings for the TxD and RxD signals of your IR peripheral component, you need to consult the components manual.



### ▶ Onboard Parallel Port

This item allows you to determine the I/O address and the IRQ for the onboard parallel port. The default settings are adequate and should not give you any problems. If they do you can try to change them.

### ▶ Parallel Port Mode

This field allows you to select an operating mode for the onboard parallel (printer) port. Select Normal, Compatible, or SPP unless you are certain your hardware and software both support one of the other available modes.

### ▶ EPP Mode Select

This field allows you to choose the EPP version you want to use. We recommend that you use EPP 1.9 for the best performance but if you do you may have some connection problems so try setting it to EPP 1.7.

### ▶ ECP Mode Use DMA

This item allows you to select a DMA channel for the parallel port for use during ECP.

### ▶ Game Port Address

This field allows you to select the I/O address for the onboard game port. The default is 201.

### ▶ Midi Port Address

This field allows you to select the I/O address for the onboard MIDI port. The default is 330.

### ▶ MIDI Port IRQ

This field allows you to select the IRQ for the onboard MIDI port. The default is 10.

## Init Display First

This field allows a user, with two graphics cards installed on his system, to select which graphics card will be activated first: either the PCI graphics card or the AGP graphics card. If you have only installed one graphics card the BIOS will automatically detect it and you do not need to set this field.

## OnChip USB Controller

This field allows you to enable or disable the onboard USB controller.

## USB Keyboard Support

This field should only be enabled if you are using a USB keyboard. If you are not using this kind of keyboard you should disable it.



## IDE HDD Block Mode

Block mode is also known as block transfer, multiple commands, or multiple sector read/write. If your IDE hard drive supports block mode select "Enabled" for automatic detection of the optimal number of block read/writes per sector the drive can support.

## 3.7. Power Management Setup

CMOS Setup Utility - Copyright (C) 1984 - 2001 Award Software  
Power Management Setup

ACPI Function	[Enabled]	Item Help
ACPI Suspend Type	[S1(POS)]	Menu Level ▾
Power Management Option	[User Define]	
HDD Power Down	[Disable]	
Suspend Mode	[Disable]	
Video Off Option	[Suspend -> Off]	
Video Off Method	[Blank Screen]	
MODEM Use IRQ	[3]	
Soft-Off by PWRBTN	[Instant-Off]	
PWRON After PWR-Fail	[Off]	
▸ IRQ/Event Activity Detect	[Press Enter]	

### ACPI function

This item allows you to enable/disable the Advanced Configuration and Power Management (ACPI).

### ACPI Suspend Type

This field allows you to select the mode of the suspended state.

### Power Management Option

This category allows you to select the degree of power saving. The choices are shown below.

Power Management	
Min. Saving	Minimum power management. Suspend Mode = 1 hr.
Max. Saving	Maximum power management. Suspend Mode = 1 min.
User Defined	Allows you to set each mode individually. When not disabled, each of the ranges are from 1 min. to 1 hr. except for HDD Power Down which ranges from 1 min. to 15 min. and disable.



# Managing The PC BIOS



## HDD Power Down

When enabled and after the set time of system inactivity, the hard disk drive will be powered down while all other devices remain active.

## Suspend Mode

When enabled, after the set time of system inactivity, all devices except the CPU will be shut off.

## Video Off Option

When enabled, this feature allows the VGA adapter to operate in a power saving mode.

Always On	Monitor will remain on during power saving modes.
Suspend --> Off	Monitor blanked when the systems enters the Suspend mode.

## Video Off Method

This determines the manner in which the monitor goes blank.

V/H SYNC+Blank	This selection will cause the system to turn off the vertical and horizontal synchronization ports and write blanks to the video buffer.
Blank Screen	This option only writes blanks to the video buffer.
DPMS Support	Select this option if your monitor supports the Display Power Management Signaling (DPMS) standard of the Video Electronics Standards to select video power management values.

## MODEM Use IRQ

This determines the IRQ which the MODEM can use for power saving purposes. This mainboard has the ACPI feature designed on the board and it will "wakeup" automatically when it detects an incoming modem Ring-in signal. Before you can use the Ring-in signal to wakeup your PC system, you have to install the "External" modem to your PC system and tell the PC system which serial port connects to the modem by selecting the IRQ in this field, (officially, COM 1 uses IRQ4, and COM 2 uses IRQ3).

## Soft-Off by PWRBTN

Pressing the power button for more than 4 seconds forces the system to enter the Soft-Off state when the system has "hung".



# Managing The PC BIOS



## PWRON After PWR-Fail

<b>Off:</b>	When the power returns after an AC power failure the system's power is off. You must press the Power button to power-on the system
<b>Former - Sts:</b>	When power returns after an AC power failure, the system will return to the state where you left off before the power failure occurred. If the system's power is off when the AC power failure occurred, it will remain off when the power returns. If the system's power is on when the AC power failure occurred, the system will power-on when the power returns.

## IRQ/Event Activity Detect

CMOS Setup Utility - Copyright (C) 1984 - 2001 Award Software IRQ/Event Activity Detect		
VGA	[OFF]	Item Help
LPT & COM	[LPT/COM]	
HDD & FDD	[ON]	
PCI Master	[OFF]	Menu Level ▶▶
PowerOn by PCI Card	[Disabled]	
Modem/LAN Resume	[Disabled]	
RTC Alarm Resume	[Disable]	
d X Date (of Month)	0	
X Resume Time (hh:mm:ss)	0 : 0 : 0	
▶ IRQs Activity Monitoring	[Press Enter]	

### ▶ VGA

When you enable this option, any VGA signal will wake up the system.

### ▶ LPT & COM

When this field is "ON" any activity from these devices, or their IRQ's will wake up the system.

### ▶ HDD & FDD

When this field is "ON" any activity from the HDD or the FDD will wake up the system.

### ▶ PCI Master

When you enable the PCI Master mode, any activity from one of the listed system peripheral devices wakes up the system.

### ▶ Power On by PCI Card

The system can be woken up by the PME# on the PCI card.

### ▶ Modem/LAN Resume

An input signal from the modem/LAN will wake up the system from a soft off state.



## Managing The PC BIOS



### ▶ RTC Alarm Resume

When enabled, you can use the following two fields to select the time and date to wake up the PC system from power saving mode.

### ▶ Date (of Month)/Resume Time (hh:mm:ss)

When RTC Alarm Resume is enabled, you can set the date and time at which the RTC (real-time clock) alarm awakens the system from Suspend mode.

### ▶ IRQs Activity Monitoring

The following is a list of IRQ's, Interrupt ReQuests, which can be exempted much as the COM ports and LPT ports above can. When an I/O device wants to gain the attention of the operating system, it signals this by causing an IRQ to occur. When the operating system is ready to respond to the request, it interrupts itself and performs the service.

CMOS Setup Utility - Copyright (C) 1984 - 2001 Award Software IRQs Activity Monitoring			
Primary INTR	[ON]	Item Help	
IRQ3 (COM 2)	[Disabled]	Menu Level >>>	
IRQ4 (COM 1)	[Enabled]		
IRQ5 (LPT 2)	[Enabled]		
IRQ6 (Floppy Disk)	[Enabled]		
IRQ7 (LPT 1)	[Enabled]		
IRQ8 (RTC Alarm)	[Disabled]		
IRQ9 (IRQ2 Redir)	[Disabled]		
IRQ10 (Reserved)	[Disabled]		
IRQ11 (Reserved)	[Disabled]		
IRQ12 (PS/2 Mouse)	[Enabled]		
IRQ13 (Coprocessor)	[Enabled]		
IRQ14 (Hard Disk)	[Enabled]		
IRQ15 (Reserved)	[Disabled]		
<b>Note:</b> When set On, activity will neither prevent the system from going into a power management mode nor awaken it.			

### 3.8. PNP/PCI Configuration (Menu on page 42: [click here](#))

#### PNP OS Installed

This item allows you to determine if a PnP OS is installed or not.

#### Reset Configuration Data

Normally, you leave this field Disabled. If you have installed a new add-on and the system reconfiguration has caused such a serious conflict that the operating system cannot boot then select Enabled. Selecting Enabled will reset the Extended System Configuration Data (ESCD).



# Managing The PC BIOS



CMOS Setup Utility - Copyright (C) 1984 - 2001 Award Software  
PNP/PCI Configurations

PNP OS Installed	[No]	Item Help
Reset Configuration Data	[Disabled]	
Resources Controlled By	[Auto(ESCD)]	Menu Level >  Select Yes if you are using a Plug and Play capable operating system. Select No if you need the BIOS to configure non-boot devices.
x IRQ Resources	[Press Enter]	
PCI/VGA Palette Snoop	[Disabled]	
Assign IRQ For VGA	[Enabled]	
Assign IRQ For USB	[Enabled]	

## Resources controlled By

Award Plug and Play BIOS has the capacity to automatically configure all of the boot and Plug and Play compatible devices. However, this capability means absolutely nothing unless you are using a Plug and Play operating system such as Windows 98.

## IRQ Resources

When resources are controlled manually, assign each system interrupt a type, depending on the type of device using the interrupt

## PCI/VGA Palette Snoop

Leave this field at *Disabled* all the time

## Assign IRQ For VGA/USB

A system's IRQs are limited. Sometimes you may need to use more IRQ signals for your add-on cards. BIOS allows you to disable the IRQ which is supposed to be connected to the VGA and USB ports. If you choose to disable the IRQ on the VGA or USB port, the IRQ will be released and becomes available for other devices. Please make sure that you have a USB or VGA adapter that does not need an IRQ before you select Disabled.

## 3.9. PC Health Status (Menu on page 43: click here)

The PC Health Status menu allows you to monitor the health status of your PC system. You can select a field of interest and monitor its status.

## CPU Warning Temperature

This field allows you to select an operating temperature range for your CPU. If the CPU temperature moves out of this range, any warning mechanism you have programmed into your system will be activated.



# Managing The PC BIOS



CMOS Setup Utility - Copyright (C) 1984 - 2001 Award Software  
PC Health Status

CPU Warning Temperature	[Disabled]	Item Help
Current CPU Temperature	45° C / 113° F	
Current CPU FAN Speed	4821 RPM	Menu Level >
Current CHASSIS FAN Speed	0 RPM	
Vcore (V)	1.74 V	
Vcc3 (V)	3.42 V	
+ 5 V	5.11 V	
+ 12 V	12.09 V	
- 12 V	12.11 V	
VBAT (V)	3.23 V	
5VSB (V)	5.26 V	
Shutdown Temperature	[Disabled]	

### Current CPU Temp.

This field shows the current temperature for CPU.

### Current CPU FAN Speed

This field shows you the present CPU Cooling FAN speed.

### Current Chassis FAN Speed

This field shows you the Chassis Cooling FAN speed.

### Vcore

This field and the files below show you the current system voltage

### Shutdown Temperature

When the system reaches a certain maximum temperature the system will automatically shutdown.

## 3.10. Frequency/Voltage Control

CMOS Setup Utility - Copyright (C) 1984 - 2001 Award Software  
Frequency/Voltage Control

CPU Clock Ratio	[X 8]	Item Help
Auto Detect DIMM/PCI Clk	[Disabled]	
Spread Spectrum	[Disabled]	Menu Level >
CPU Clock	[100 MHz]	



# Managing The PC BIOS



## CPU Clock Ratio

This field allows you to select the clock ratio. Most CPU clock ratios are fixed inside the CPU by the manufacturers that prohibit you to make any changes. In this case, the setting in this field will make no change to the CPU clock ratio since it locks and is automatically determined by the CPU.

## Auto Detect DIMM/PCI Clk

When "Enabled" is selected, the mainboard will detect the presence of devices on DIMM and PCI slots. When there is no device present on some of the PCI or DIMM connectors, the clock on the related DIMM and PCI slot will be disabled to reduce the Electro-Magnetic Interference (EMI).

## Spread Spectrum

When Spread Spectrum is enabled, the EMI radiation on this mainboard will be reduced.

## CPU Clock

You can use this field to adjust the front side system bus clock speed of the CPU. The clock frequency can be incremented by +/- 1MHz. This allows you to fine-tune the system performance of your PC.

<b>3.11. Load Fail-Safe Defaults</b>	
CMOS Setup Utility – Copyright ( C ) 1984 - 2001 Award Software	
<ul style="list-style-type: none"> <li>▶ Standard CMOS Features</li> <li>▶ Advanced BIOS Features</li> <li>▶ Advanced Chipset Features</li> <li>▶ Integrated Peripherals</li> <li>▶ Power Management Setup</li> <li>▶ PNP/PCI Configuration</li> <li>▶ PC Health Status</li> </ul>	<ul style="list-style-type: none"> <li>▶ Frequency/Voltage Control</li> <li style="background-color: #800000; color: white; padding: 2px;">Load Fail-Safe Defaults</li> <li>Load Optimized Defaults</li> <li>Set Supervisor Password</li> <li>Set User Password</li> <li>Save &amp; Exit Setup</li> <li>Exit Without Saving</li> </ul>
Esc : Quit      F9 : Menu in BIOS      ← ↑ ↓ → : Select Item F10 : Save and Exit Setup	
Time, Date, Hard Disk Type ...	

This option loads troubleshooting default values which are permanently stored on the BIOS ROM Chip. If you made changes to the BIOS settings and your system has become unstable, you can change it back to the default settings. If you have made many changes to the BIOS settings and you are not sure which setting is causing the problem then you should choose this option. This will load the minimal performance settings and stabilize your system.



## 3.12. Load Optimized Defaults

CMOS Setup Utility – Copyright ( C ) 1984 - 2001 Award Software	
<ul style="list-style-type: none"> <li>▶ Standard CMOS Features</li> <li>▶ Advanced BIOS Features</li> <li>▶ Advanced Chipset Features</li> <li>▶ Integrated Peripherals</li> <li>▶ Power Management Setup</li> <li>▶ PNP/PCI Configuration</li> <li>▶ PC Health Status</li> </ul>	<ul style="list-style-type: none"> <li>▶ Frequency/Voltage Control</li> <li>Load Fail-Safe Defaults</li> <li><b>Load Optimized Defaults</b></li> <li>Set Supervisor Password</li> <li>Set User Password</li> <li>Save &amp; Exit Setup</li> <li>Exit Without Saving</li> </ul>
Esc : Quit      F9 : Menu in BIOS      ← ↑ ↓ → : Select Item F10 : Save and Exit Setup	
Time, Date, Hard Disk Type ...	

There is CMOS memory on the mainboard that can be used to store the system settings. If you don't know how to use the Award BIOS CMOS Setup Utility to select the settings, you may use this field to load the optimized defaults which are defined in the system BIOS. **Our engineer recommends the Optimized Defaults.** If this option is selected it will give a series of parameters that will ensure the reliability and performance of your PC.

If you lose your CMOS data or you don't know how to complete the setup procedure, you may use this option to load the Optimized default values from the BIOS default table.

If the CMOS data is corrupted, or if you selected some CMOS settings and find that the PC system becomes very unstable, you should try to load the optimized

## 3.13. Set Supervisor Password

The "SUPERVISOR PASSWORD" is for you to control unauthorized access to your BIOS CMOS Setup or Booting into the your PC system. The Supervisor Password option is used together with the Security Option in [section 3.5. \(click here\)](#)

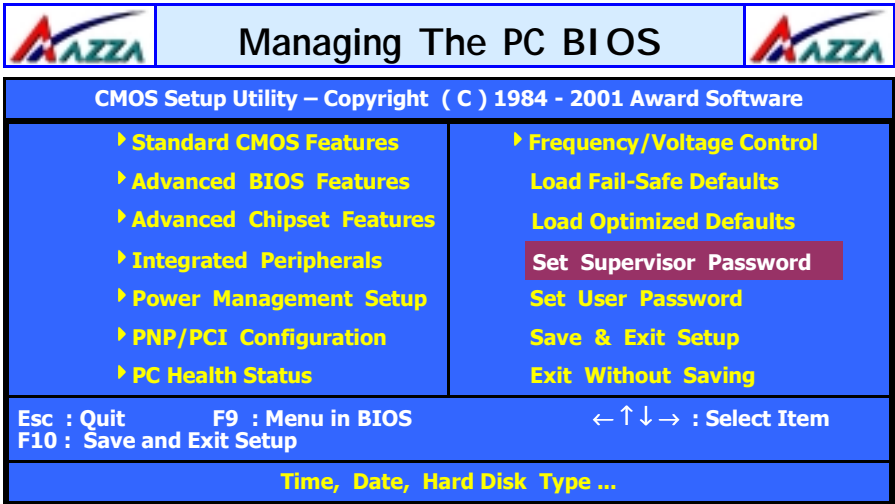

When "Setup" is selected in the Security Option:

If you want to change any BIOS setting, you will have to key-in the Supervisor Password so that you can start the BIOS CMOS Setup Utility and change the system setting.

When "System" is selected in Security Option:

Whenever you turn on the PC, it will request the user to enter the Password in order to boot up your system. Without the correct password, the PC system will

### 3.14. Set User Password

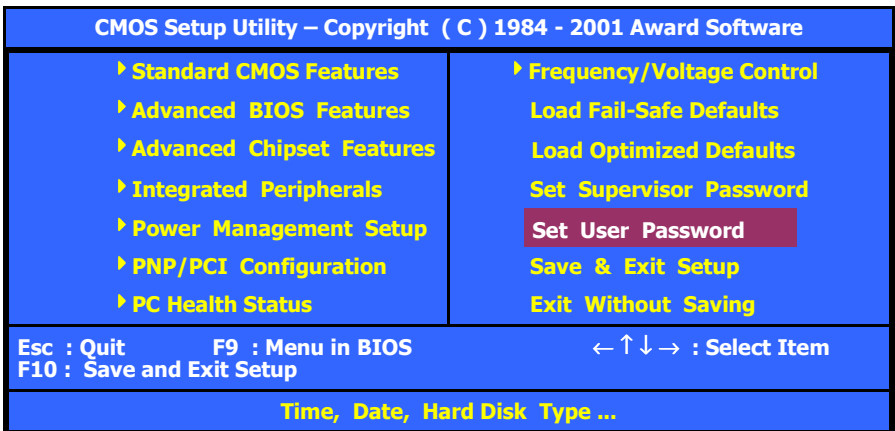



# Managing The PC BIOS



The User Password can be used to check the user's authority. However, this password entry is different from the "SUPERVISOR PASSWORD". The User Password has a different function to the "Supervisor Password" and the "Security Option" setup in Section 3.5. ([Click here](#)):

## A. When there is the password stored in the "SUPERVISOR PASSWORD"

### 1. When "Setup" is selected in the Security Option:

When you use the "User Password" to log into the BIOS setup program, you can only view the BIOS settings, but you cannot change any settings. The only setting you can change is the "User Password" and you can also select "SAVE & EXIT SETUP" and "EXIT WITHOUT SAVING" from the main menu. (If you use the Supervisor Password to log into the PC system, you will have the complete rights to all the BIOS settings.

### 2. When "System" is selected in Security Option:

When you turn on the PC system, it will request that you enter the Password. Without the correct password, the PC system will stop and the operating system won't be loaded.

## B. When there is no password stored in the "SUPERVISOR PASSWORD"

### 1. When "Setup" is selected in Security Option:

Users can use the "User Password" to log into the BIOS setup program, and they can change any of the BIOS settings.

### 2. When "System" is selected in Security Option:

When you turn on your PC, you will be requested to enter the Password. Without the correct password, the PC system will stop and the operation system will not be loaded.

## 3.15. Save & Exit Setup / Exit Without Saving

CMOS Setup Utility – Copyright ( C ) 1984 - 2001 Award Software	
<ul style="list-style-type: none"> <li>▶ Standard CMOS Features</li> <li>▶ Advanced BIOS Features</li> <li>▶ Advanced Chipset Features</li> <li>▶ Integrated Peripherals</li> <li>▶ Power Management Setup</li> <li>▶ PNP/PCI Configuration</li> <li>▶ PC Health Status</li> </ul>	<ul style="list-style-type: none"> <li>▶ Frequency/Voltage Control</li> <li>Load Fail-Safe Defaults</li> <li>Load Optimized Defaults</li> <li>Set Supervisor Password</li> <li>Set User Password</li> <li>Save &amp; Exit Setup</li> <li>Exit Without Saving</li> </ul>
Esc : Quit      F9 : Menu in BIOS      ← ↑ ↓ → : Select Item F10 : Save and Exit Setup	
Time, Date, Hard Disk Type ...	



## Managing The PC BIOS



### Save & Exit Setup

This option will save all the setup values to CMOS RAM and exit the SETUP utility. Move the selection bar to "SAVE & EXIT SETUP" and press the "Enter" key, then type "Y" and press the "Enter" key again. The values you have entered will be saved and all the information stored in the CMOS memory.

### Exit Without Saving

This option will exit the setup utility without saving any of the values you changed in the CMOS RAM. If you do not want to save any of the changes, or settings you selected in the BIOS SETUP utility, move the selection bar to the "EXIT WITHOUT SAVING" option. Press the "Enter" key. Then press "Y"