

The **AZZA** 366 Mainboard Series

Cover [Click Here](#)

Table Of Contents [Click Here](#)

Introduction [Click Here](#)

Hardware Installation [Click Here](#)

BIOS Management [Click Here](#)



*Create High Quality
Service and Technology*



366 Mainboard

SOCKET A DDR ATX Mainboard

366A-AV

366A-BV

366X-AS

366X-AV

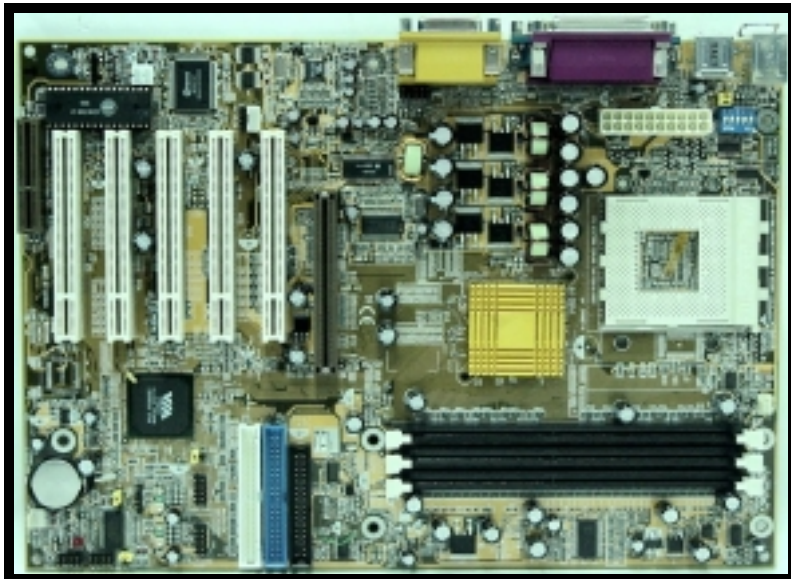

Version 1.x

UM-366XAABSV-E1

Rev 1.0V

Creation Date: 31 October 2001



Copyright

This publication contains information that is protected by copyright. No part of it may be reproduced in any form or by any means or used to make any transformation adaptation without prior written permission from the copyright holders. This publication is provided for informational purposes only. The manufacturer makes no representations or warranties with respect to the contents or use of this manual and specifically disclaims any express or implied warranties of merchantability or fitness for any particular purpose. The user will assume the entire risk of the use or the results of the use of this document. The manufacturer reserves the right to revise this publication and make changes to its contents at any time, without prior notice.

2001. All Rights Reserved.

Trademarks

Microsoft®, MS-DOS®, Windows™, Windows® 95 and Windows® 98 are registered trademarks of Microsoft Corporation. AMD Duron™, AMD Athlon™ and Athlon™XP are registered trademarks of AMD corporation. Award is the registered trademark of Award Software, Inc. Other trademarks and registered trademarks of products appearing in this publication are the properties of their respective holders.

Package Checklist

This package contains the following items:

- Mainboard
- Users manual
- One IDE cable
- One 34-pin floppy disk drive cable
- One Driver Utility CD

If any of these items are damaged or missing, please contact your dealer or sales representative for assistance.

Technical Support

If you require additional information or assistance during installation please contact your dealer. Your dealer will be able to provide the latest information.



Table of Contents



Chapter 1:- Introduction *Page 5*

1.1. Mainboard and PC99 External Connector Layout	5
1.2. Overview	6
1.2.1. The 366 Mainboard Series	6
1.2.2. Mainboard Dimensions.....	6
1.2.3. Environmental Limitations.....	6
1.3. Features and Specifications.....	6
1.4. System Health Monitor Functions.....	9
1.4.1. Hardware Monitoring System Utility.....	9
1.4.2. Installation.....	9
1.5. System Intelligence.....	9

Chapter 2:- Hardware Installation *Page 11*

2.1. Installation Checklist.....	11
2.2. Installation Steps	12
2.3. Expansion Slots, Jumpers and Internal Connectors.....	13
2.4. CPU, Memory and Expansion Slots	14
2.4.1. Installation of the CPU.....	14
2.4.2. Memory Modules.....	14
2.4.3. PCI Slots.....	15
2.4.4. AGP (Accelerated Graphics Port) Slot.....	15
2.4.5. CNR (Communications Network Riser) Slot.....	16
2.5. Internal Connectors.....	16
2.5.1. Floppy Disk Drive (FDD)	16
2.5.2. Primary and Secondary IDE Connectors.....	16
2.5.3. Standard Infrared Connector.....	17
2.5.4. CPU and Chassis Fan Connectors.....	17
2.5.5. ATX Power Supply Connector	18
2.5.6. WOL (Wake-On-LAN) and WOM (Wake-On-Modem) Connectors	18
2.5.7. CD Audio In Connector	19
2.5.8. USB 3, USB 4, USB 5 and USB 6 Connectors	19
2.5.9. S/PDIF Connector.....	20
2.6. System Panel Buttons and LED Connectors.....	20
2.6.1. PW: Power On / Off and External Suspend Switch Connector	20
2.6.2. SL LED Connector	21
2.6.3. IDE HDD LED Connector.....	21
2.6.4. Reset Button Connector	21



Table of Contents



2.7. Speaker and Power LED Connector	21
2.7.1. Speaker Connector	21
2.7.2. Front Panel Power LED	21
2.8. External Connectors	22
2.8.1. PS/2 Keyboard Connector	22
2.8.2. PS/2 Mouse Connector	22
2.8.3. COM 1 and COM 2 Connectors	22
2.8.4. Parallel Port Connector	22
2.8.5. USB 1 and USB 2 Connectors	23
2.8.6. Audio Game Port Connector	23
2.9. Jumper Settings	23
2.9.1. JP1: USB 1 and USB 2 Power	23
2.9.2. JP2: Keyboard Power	24
2.9.3. JP6: CPU Clock	24
2.9.4. JP8: Clears CMOS Memory	24
2.10. Switches: CPU Clock Ratio Selection	24

Chapter 3:- Managing The PC BIOS *Page 26*

3.1. AWARD BIOS CMOS Setup Utility	26
3.2. Main Menu	26
3.3. Standard CMOS Setup	27
3.4. Advanced BIOS Features	29
3.5. Advanced Chipset Features	32
3.6. Integrated Peripherals	35
3.7. Power Management Setup	39
3.8. PNP/PCI Configuration	42
3.9. PC Health Status	43
3.10. Frequency/Voltage Control	44
3.11. Load Optimized Defaults	45
3.12. Set Supervisor Password	46
3.13. Set User Password	47
3.14. SAVE & EXIT SETUP/EXIT WITHOUT SAVING	48

Chapter 1 - Introduction

1.1. Mainboard And PC99 ATX External Connector Layout

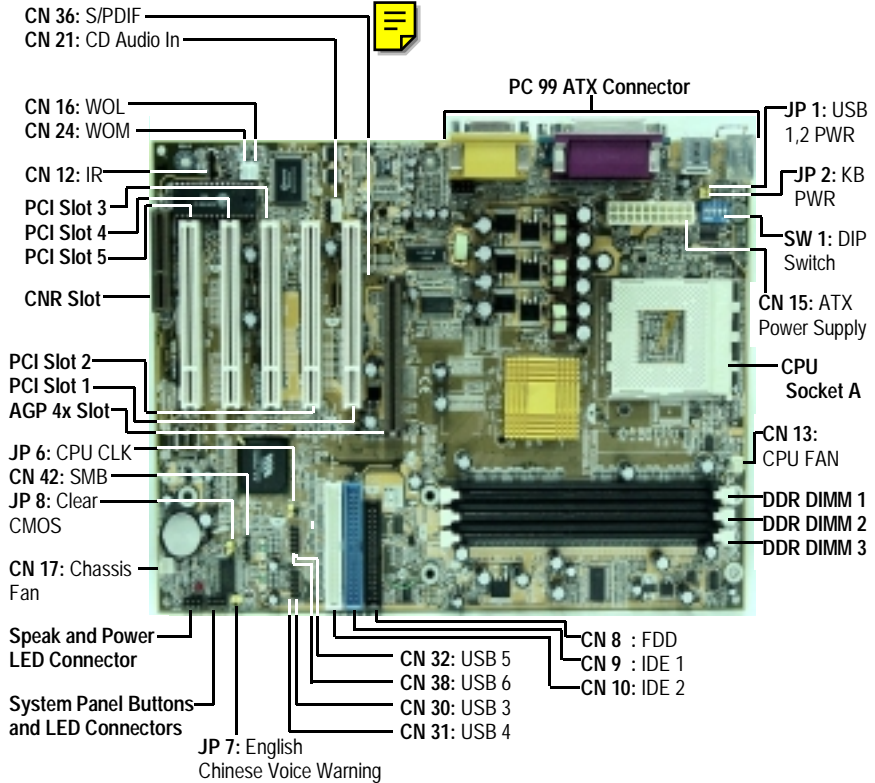

PC99 ATX External Connector

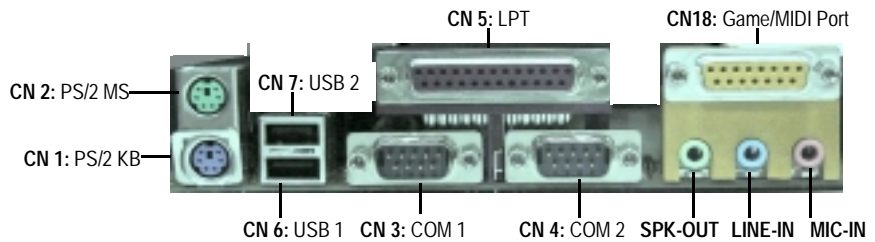



Introduction



1.2. Overview

1.2.1. 366 Series

There are four models in this series.

- | | |
|--------------|------------|
| 1. 366A - AV | 3. 366X-AS |
| 2. 366A - BV | 4. 366X-AV |

The 366X models have a different North Bridge Chipset to the 366A models. The 366A-AV model and the 366A-BV model have a different Southbridge Chipset.

1.2.2. Mainboard Dimensions

Width	305 mm
Length	220 mm

1.2.3. Environmental Limitations

Operating Temperature:	10°C to 40°C (50°F to 104°F)
Required Airflow:	50 linear feet per minute across the CPU
Storage Temperature:	-40°C to 70°C (-40°F to 158°F)
Humidity:	0 to 90% non-condensing
Altitude:	0 to 10 000 feet

1.3. Features and Specifications

Processor

Socket A based AMD Athlon™XP, Athlon™ and Duron™ processors are supported by these mainboards.

Northbridge Core Chipset

VIA KT266A:	366A-AV and 366A-BV
VIA KT266 :	366X-AS and 366X-AV

Southbridge Core Chipset

VIA VT8233	366A-AV, 366X-AS and 366X-AV
VIA VT8233A	366A-BV

I/O Chipset

Winbond W83697HF

CPU Switching Voltage regulator

This mainboard is equipped with a switching voltage regulator that automatically detects a DC power supply from +1.10V to +1.85V.

CPU Vcore Select (only available for 366X-AS)

You can use the system BIOS to select the CPU Vcore Voltage.



Introduction



CPU Clock Ratio Selection (only available for 366X-AS)

This mainboard comes with an onboard Dip Switch, **SW1**. **SW1** can be used to set the CPU clock ratio. **Note:** You can not change the CPU Clock Ratio on all CPU's. This function depends on the CPU you are using.

System Memory

The 366 mainboard series uses Double Data Rate Dual Inline Memory Modules (DDR DIMM). Each mainboard has three 184-pin DIMM sockets. These sockets support 2.5V (power level) single-sided or double sided PC-1600 or PC-2100 DDR DIMM modules. The maximum memory supported by these mainboards is 3 GB.

Expansion Slots

These mainboards are equipped with five dedicated PCI slots, one CNR slot (**not available for the 366A-BV**), which is shared with PCI 5, and one 4x AGP slot.

Onboard Audio Features

Supports Microsoft DirectSound/ DirectSound 3D and AC97 Full Duplex.

Word Size

- Data Path: 8-bit, 16-bit, 32-bit, 64-bit
- Address Path: 32-bit

Front Side Bus Frequency (FSB)

For a 200 MHz CPU the mainboard supports a 100 MHz FSB. For a 266 MHz CPU the mainboard supports a 133 MHz FSB.

BIOS

- Award BIOS, Windows 95/98 Plug and Play (PnP) compatible.
- Supports SCSI sequential boot-up.
- Flash EPROM for easy BIOS upgrades.
- Supports DMI 2.0 function

Desktop Management Interface (DMI)

The mainboard comes with DMI 2.0 built into the BIOS. The DMI utility in the BIOS will automatically record different information about your system configuration and store this information in the DMI pool, which is a part of the system board's Plug and Play BIOS. DMI, along with the appropriately networked software, is designed for easy inventory, maintenance and the simplified troubleshooting of computer systems.

WOL (Wake-On-LAN) Port

One WOL connector supports Wake-On-LAN functionality.

WOM (Wake-On-Modem) Port

One WOM connector supports Wake-On-Modem functionality.



Introduction



USB Ports

USB allows data exchange between your computer and a wide range of simultaneously accessible external Plug and Play peripherals. The **366X-AS**, **366X-AV** and **366A-AV** models are equipped with 6 USB connectors. The **366A-BV** models are equipped with four USB connectors. USB 1 and USB 2 are external connectors. They can be found on the PC 99 ATX connector. The other USB connectors are internal connectors and can be used to connect other USB devices. (Cables for the internal connectors are sold separately).

Please note that the internal USB connectors are non-standard. When you purchase the cable please ensure that the connector on one side of the cable is compatible with the internal USB connector and the connector on the other side of the cable is a standard USB connector.

Connectors

- One connector for IrDA interface (**optional**).
- Two IDE connectors.
- One floppy drive interface supports up to two 2.88MB floppy drives.
- One 20-pin ATX power supply connector.
- CPU and chassis fan connectors.
- One CD audio-in connector.
- One internal audio digital interface (S/PDIF) connector. (**optional**)
- One system management bus (SMB) connector. (**optional**)

ATX Double Deck Ports (PC 99 color-coded connectors)

- Two USB ports.
- Two external DB-9 serial port connector: **COM 1** and **COM 2** (UART).
- One SPP/ECP/EPP DB-25 parallel port.
- One mini-DIN-6 PS/2 mouse port.
- One mini-DIN-6 PS/2 keyboard port.
- One game/MIDI port.
- Three audio jacks: speak-out, line-in and mic-in.

PCI Bus Master IDE Controller

- Two PCI IDE interfaces support up to four IDE devices.
- The **366X-AS**, **366X-AV** and **366A-AV** models support ATA/33, ATA/66 and ATA/100 hard drives.
- The **366A-BV** models support ATA/33, ATA/66 and ATA/100 and ATA/133 hard drives.
- PIO Mode 3 and Mode 4 Enhanced IDE (data transfer rate up to 16.6MB/sec.).
- Bus mastering reduces CPU utilization during disk transfer.
- Supports ATAPI CD-ROM, LS-120 and ZIP.



Introduction



IrDA Interface (optional)

The mainboard is equipped with an IrDA connector for wireless connectivity between your computer and peripheral devices. It supports peripheral devices that meet the HPSIR or ASKIR standard.

1.4. System Health Monitor Functions

The mainboard is capable of monitoring the following health conditions of your system:

1. Processor temperature. It has an overheat alarm.
2. VCORE/3.3V/5V/12V/-12V voltages and failure alarm.
3. Processor and chassis fan speeds. It has a failure alarm for these fans.
4. Read back capability that displays temperature, voltage and fan speed.

Note: Only use this utility in Windows ® 95 or Windows ® 98 operating systems.

1.4.1. Hardware Monitoring System Utility

The mainboard comes with the Hardware Monitoring System utility contained on the CD. It is capable of monitoring the system's hardware conditions such as the temperature of the processor, voltage, and the speed of both the CPU and chassis fans. You are allowed to manually set a range to the items being monitored. If the values are over or under the set range a warning message will automatically pop up. We recommend that you use the Default Settings, which are the ideal settings that will maintain the system in a good working condition.

1.4.2. Installation

To install this utility, please insert the CD into the CD-ROM drive. The auto run screen (Driver Utility) will automatically appear. Click the Hardware Monitoring button, choose the chipset, model number and the OS that is installed. Please refer to the CD "Readme" file for further installation instructions.

1.5. System Intelligence

Dual Function Power Button

Depending on the setting in the Soft-Off By Power-Button field of the Power Management Setup, this switch allows the system to enter the Soft-Off or Suspend mode.

External Modem Ring-on (optional)

The Modem Ring-on feature allows the system that is in the Suspend mode or Soft Power Off mode to wake-up/power-on to respond to incoming calls. This feature supports the external modem only.

RTC Timer to Power-on the System

The RTC installed on the system board allows your system to automatically power-on at a set date and time.



Introduction



Wake-On-LAN Ready

The Wake-On-LAN function allows the network to remotely wake up a Soft Power Down (Soft-Off) PC. Your LAN card must support the remote wakeup function. The 5V SB power source of your power supply must be at least 720mA.

ACPI Ready

The mainboard is designed to meet the ACPI (Advanced Configuration and Power Interface) specification. ACPI has energy saving features that support OS Direct Power Management (OSPM) for round the clock PC operation.



Chapter 2 - Hardware Installation

2.1. Installation Checklist



The following is a checklist of all the expansion slots, jumpers and connectors that should be configured on your mainboard before you can run your pc.

Installation Checklist		
Expansion Slots and Sockets		
CPU Socket	Socket A based AMD® Athlon™XP, Athlon™ and Duron™ processors	
DIMM Slots	Three 184 pin slots that supports up to 3GB of DDR SDRAM .	
PCI Slots	Five 32 bit PCI Slots.	
AGP Slot	One Accelerated Graphics Port Slot	
CNR Slot	One Communication Network Riser Slot (not available on 366A-BV).	
Internal Connectors		
CN8	Floppy Disk Drive	FDC
CN9	Primary IDE	IDE1
CN10	Secondary IDE	IDE2
CN12	Infrared	IR (optional)
CN13	CPU Fan	CPU Fan
CN15	ATX Power Supply	ATX
CN16	Wake On Lan	WOL
CN17	Chassis Fan	Chassis Fan
CN21	CD Audio In	CD-In
CN24	Wake On Modem	WOM
CN30	Universal Serial Bus 3	USB3
CN31	Universal Serial Bus 4	USB4
CN32	Universal Serial Bus 5	USB5 (not available on 366A-BV)
CN36	Sony Phillips Digital Interface	S/PDIF (optional)
CN38	Universal Serial Bus 6	USB6 (not available on 366A-BV)
External Connectors		
CN1	PS/2 Keyboard Connector	PS/2 KB
CN2	PS/2 Mouse Connector	PS/2 MS
CN3	Serial Port 1	COM1
CN4	Serial Port 2	COM2
CN5	Parallel Port	LPT
CN6	Universal Serial Port 1	USB1
CN7	Universal Serial Port 2	USB2
CN18	Game/Audio Port	Audio/Game



Hardware Installation



Installation Checklist (Continued)

System Panel Buttons and LED Connectors

PW	Power On/Off and Suspend Switch Connector.
SL	Standby LED Connector
HL	HDD LED Connector
RS	Reset Button Connector

Speaker and Power LED Connector

PWR-LED	Power LED
SPK	Speaker Connector

Jumpers and Switches

JP1	USB1 and USB2 Power
JP2	Keyboard Power
JP6	CPU Clock speed selection
JP8	Clear CMOS
SW1	DIP Switch

2.2. Installation Steps

You need to complete the following installation steps before you can use your PC.

- Check and Set the Mainboard Settings.
- Install the Central Processing Unit (CPU).
- Install the Memory Modules.
- Install the Expansion Cards.
- Connect the Ribbon Cables, Panel Wires and the Power Supply.
- Setup the system BIOS

Before you start installing your mainboard we strongly recommend that you use a grounded anti-static mat. We further recommend that you attach an anti-static wristband, which is grounded at the same location as the mat, to your wrist.

2.3. Expansion Slots, Jumpers and Internal Connectors

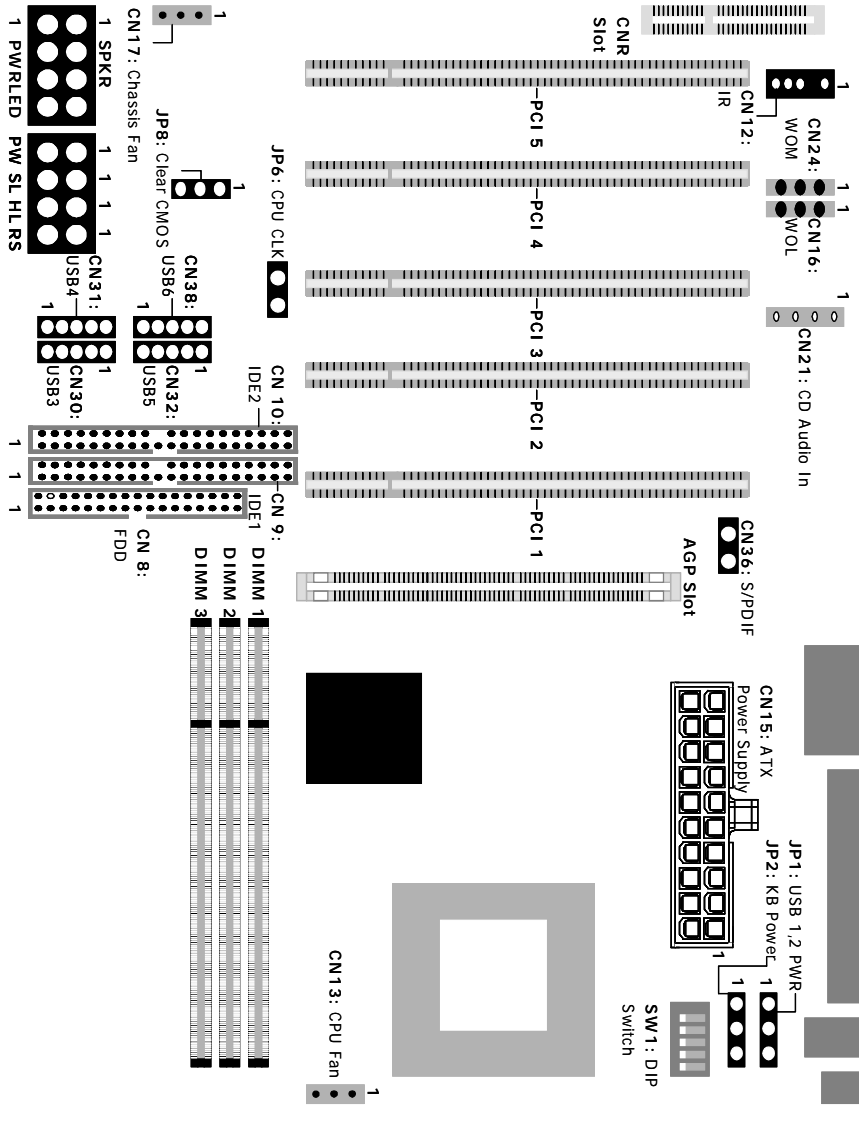



2.4. CPU, Memory and Expansion Slots

2.4.1. Installation of the CPU

To install your processor, please complete the following set of instructions

1. Locate a small dot marked on the top of the CPU. This mark indicates Pin 1 of the CPU.
2. Locate Pin 1 for the Socket on the mainboard.
3. There is a lever on the side of the socket. First push this lever sideways and then lift it to a 90-degree angle.
4. Insert the CPU into the Socket. Please make sure that Pin 1 for the CPU is inserted into Pin 1 of the Socket.
5. When the CPU is installed correctly push the lever back into place.
6. **Install a proper heat sink with cooling fan** for proper heat dissipation. Failing to install a heat sink with cooling fan may cause overheating which will burnout your CPU and damage your mainboard.

IMPORTANT: CPU COOLING FAN

Please ensure that you have an approved heat sink with cooling fan. Without a proper heat sink with cooling fan you will damage both the mainboard and the CPU.

2.4.2. Memory Modules

These mainboards all have three 184-pin DDR DIMM slots and are able to support a maximum memory of 3 GB. The DDR DIMM slots are located on the right hand side of the board. To install the DIMM's into these slots, make sure the white lever at each side of the slot has been pulled down to an angle of approximately 45°. Make sure that the DIMM is in the correct orientation. Place the DIMM on the slot and push down firmly. The white levers will come back up and lock the module in place.

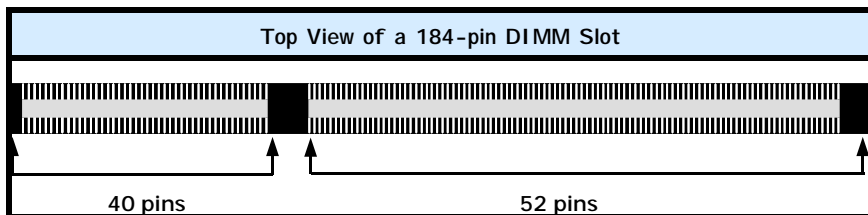

Important: The DIMM's can only be fitted into the slots in one orientation. Make sure that the DIMM's are in the correct orientation and the pins are correctly aligned before you insert them.

NOTE: "Out Of Memory" Error Message

If you have installed more than 512 MB of RAM and are running Microsoft Windows Millennium Edition, Windows 98 Second Edition, Windows 98 or Windows 95 you may experience memory problems. Two symptoms of these problems are being unable to run an MS-DOS session while you are running Windows or the computer may stop responding while Windows is starting.

There are three possible solutions to this problem:

- 1) Reduce the amount of memory Vcache uses to 512 MB or less by altering the Max-FileCache setting in the System.ini file.
- 2) Use the System Configuration Utility to reduce the amount of memory Windows uses to 512 MB or less.
- 3) Reduce the memory installed on your computer to 512 MB or less.

This problem can also occur if an Advanced Graphic Port (AGP) video adapter is used.

2.4.3. PCI Slots

These boards come with five PCI slots. They are located on the left hand side of the board. Both PCI and PCI expansion cards may require IRQ's. This mainboard complies with Plug and Play (PnP) specifications. Whenever a PnP compliant card is added the system will automatically be configured and the IRQ's will be assigned automatically.

When you are inserting your PCI card make sure that the pins are correctly aligned. When the pins are properly aligned with the hole's in the slot, push down gently.

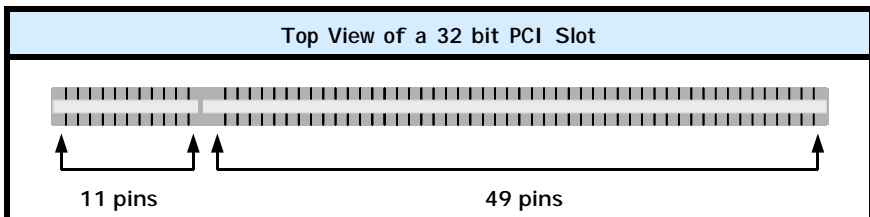

2.4.4. AGP (Accelerated Graphics Port) Slot

AGP is a dedicated bus slot. It operates at 66 MHz and transfers data at a rate up to 106 MB/s. This allows 3D applications to run more smoothly. The 366 mainboards each come with one AGP slot. These slots are able to support 1x, 2x and 4x AGP cards.

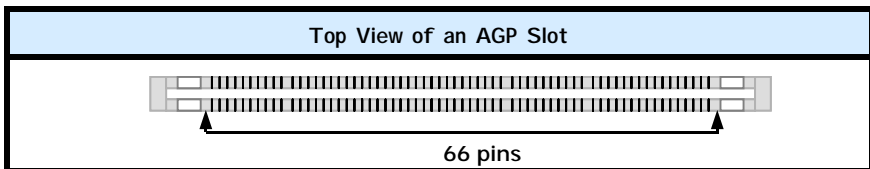

2.4.5. CNR (Communications Network Riser) Slot (not available on the 366A-BV)

These slots integrate audio, modem and networking on the same card. CNR specifications support the Audio Codec 97 (AC 97) interface, LAN interfaces, USB interfaces and System Management Bus (SMBus) interfaces (used specifically to provide Plug and Play functionality). The **366X-AS**, **366X-AV** and **366A-AV** mainboards are all equipped with a single CNR slot.

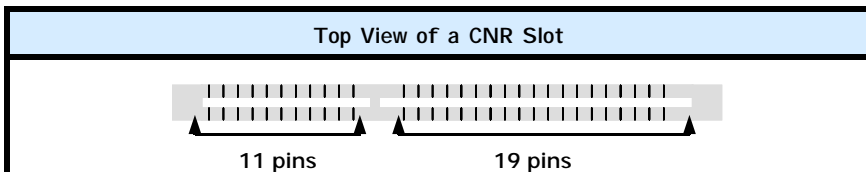

2.5. Internal Connectors

2.5.1. Floppy Disk Drive (FDD)

Connector: CN 8
Type: 34 pin block

The FDD connector can support two Floppy drives. It is located at the front of the mainboard. To connect, use the ribbon-cable that has been provided. **Make sure** that the red strip is connected to **PIN 1** of the connector.

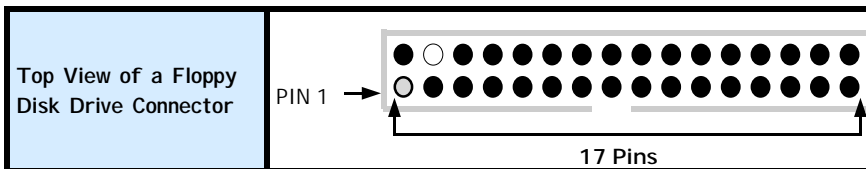

2.5.2. Primary and Secondary IDE connectors

Connector: CN 9 (primary)/ CN 10 (secondary)
Type: 40 pin blocks

The 366 mainboards all have two IDE connectors: a primary and secondary. Each IDE connector can support two IDE drives. These mainboards can therefore support up to four IDE devices each. If you install two hard drives, you need to configure the second drive to **slave** mode in the BIOS setup. Please refer to your hard drive manual for the appropriate jumper settings.

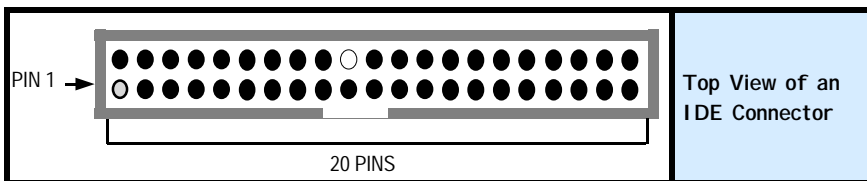

2.5.3. Standard Infrared Connector (Optional)

Connector: CN 12
Type: 5 pin

The SIR connector supports an optional wireless transmitting and receiving module. You must configure UART 2 to select whether UART 2 is directed for use with COM 2 or IrDA.

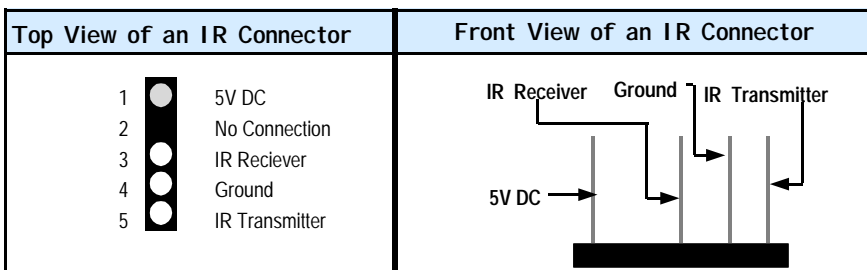

2.5.4. CPU Fan and Chassis Fan Connector

Connector: CN 13 (CPU Fan)/CN 17 (Chassis Fan)
Type: 3 pin

The cooling fans must be connected to their respective power connectors. If you have installed the hardware-monitoring feature you will be able to monitor the rotating speed of the CPU cooling fan in your Windows operating system.

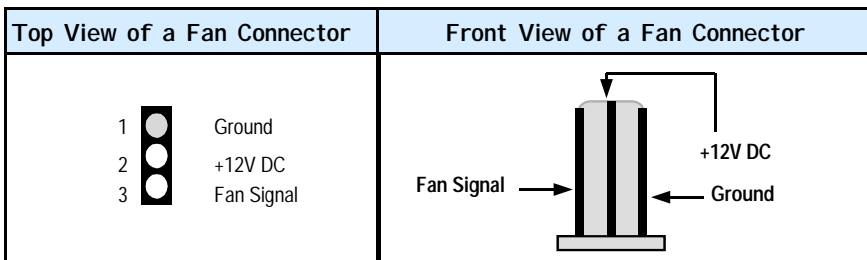

2.5.5. ATX Power Supply Connector

Connector: CN 15
Type: 20 pin block

This must be connected to an ATX power supply. The plug from the power supply can only be inserted in one orientation. Make sure the pins are correctly aligned. Find the correct orientation and push the plug down firmly.

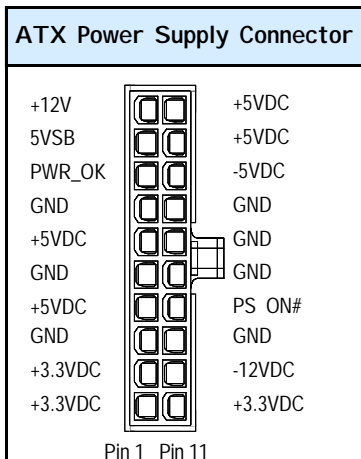

2.5.6. WOL (Wake On LAN) Connector and WOM (Wake On Modem) Connector

Connector: CN 16 (WOL)/CN 24(WOM)
Type: 3 pin

The WOL connector must be connected to a LAN card that has Wake-On-LAN (WOL) output. This connector powers up the system when a wakeup packet or signal is received through the LAN card.

The WOM connector must be connected to a Modem that has Wake-On-Modem (WOM) output. This connector powers up the system when a wakeup packet or signal is received from the Modem.

In order to use the WOL LAN card or the modem to trigger the power on the PC system, the switching power supply must have the ability to provide a driving current of at least 720 mA and be connected to a "5V standby" voltage.

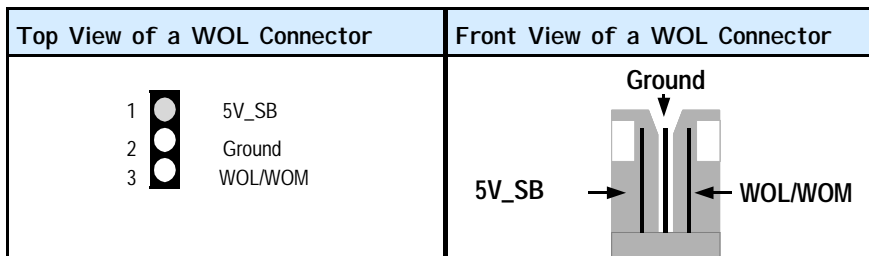

2.5.7. CD Audio-in Connector

Connector: CN 21
Type: 4 pin un-housed

This mainboard has one CD Audio-in connector. This connector is used to connect the CD ROM audio out.

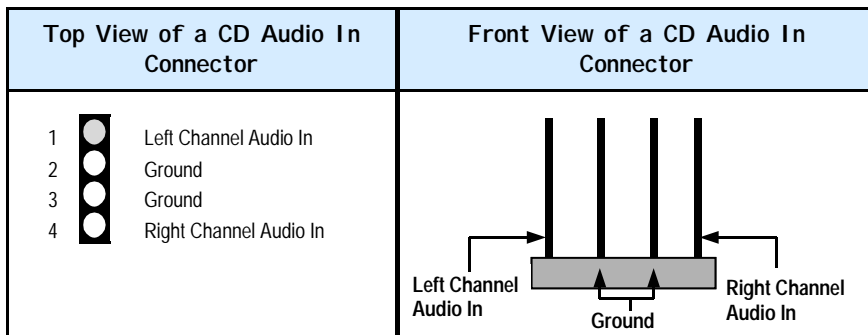

2.5.8. USB 3, USB 4, USB 5 and USB 6 connectors

Connector: CN 30 (USB 3)/CN 31 (USB 4)/CN 32 (USB 5)/CN 38 (USB 6)
Type: 5 pin / 5 pin/ 5 pin/ 5 pin

You already have two USB ports available, USB 1 and 2 (see external connectors). The internal USB connectors allow you to add on an optional kit to expand the total number of USB ports available. The **366A-AV**, **366X-AS** and **366X-AV** have four internal USB connectors (**CN30**, **CN31**, **CN32** and **CN38**). This enables you to use an extra 4 USB devices. The **366A-BV** has two internal USB connectors (**CN30** and **CN31**). This enables you to use an extra two USB devices. Cable for these additional connectors needs to be purchased separately.

Note: These are not the standard USB connectors you find on the ATX PC99 connector. To connect USB devices you need to use an expansion cable (purchased separately) that ends in a standard USB connector. Ask your retailer for more details.

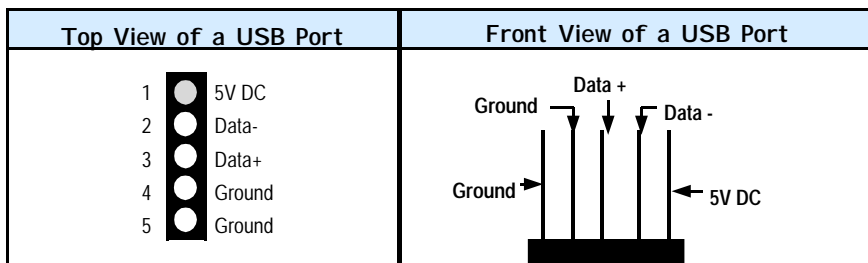

2.5.9. S/PDIF Connector (optional)

Connector: CN 36
Type: 2 pin

These mainboards come with an optional internal S/PDIF connector. S/PDIF is a digital interface that can be used to improve the quality of the sound output from your system. The diagram is on the following page.

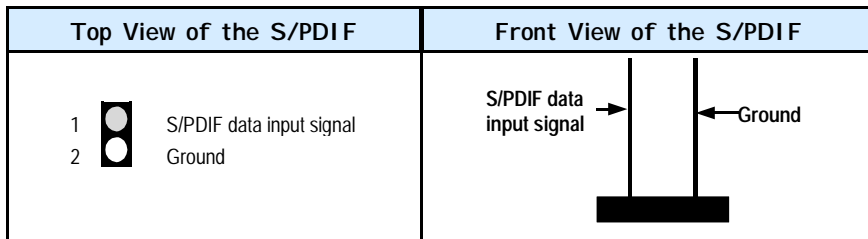

2.6. System Panel Buttons and LED Connectors

PIN 1

The following System Panel Buttons and LED Connectors can be found at the front of the mainboard on the left hand side.

PW= Power On/Off and Suspend Switch Connector
SL = Standby LED Connector
HL = HDD LED Connector
RS = Reset Button Connector

PW: +5V DC Pull Up
SL: Standby DC pull up
HL: +5V DC Pull Up
RS: Reset Control

Top View of the System Panel and LED Connectors

2.6.1 PW: Power On / Off and External Suspend Switch Connector

The Power On/Off connector has two functions. It can be the Power Switch or Suspend Switch of your PC system. You can either choose **“Delay 4 Sec”** or **“Instant OFF”** (Please refer to the Award BIOS setup instructions in Chapter 3).

Option 1: If you choose **“Delay 4 Sec.”** In the BIOS CMOS Setup, the function of **“PW”** will be:

- A. When the system power is **“OFF”**, press this switch, the system will power on.
- B. When system power is **“ON”**, you can select two different modes: -

Mode 1: Press and hold the Power ON button for less than 4 seconds and then release it. The system will be turned into Suspend mode (turned into the GREEN mode) When the system is in the Suspend mode:-



Hardware Installation



- Press the Power on button (less than 4 seconds), the system will return to Full-ON mode.
- Press and hold the Power On Button for more than 4 seconds, the system will be powered off.

Mode 2: Press and hold the Power ON button for more than 4 seconds, the system will be completely powered off.

Option 2: If you choose **"Instant OFF."** In the BIOS CMOS Setup, the power switch will operate like a normal ON / OFF Power button.

2.6.2. SL LED Connector

When the AC power is "ON" the mainboard will always have a standby voltage of +5V and the SL LED will be on. If this LED is off it means that the AC power is "OFF" or has been disconnected or Full on.

2.6.3. IDE HDD LED Connector

Any read and write activity by the HDD will turn this LED on.

2.6.4. Reset Button Connector

If you connect this connector, you will be able to reset you computer by pressing the reset button at the front of the chassis.

2.7. Speaker and Power LED Connectors

2.7.1. Speaker Connector

Connect your chassis speaker to this four pin connector. It allows you to hear systems beeps and warnings sound.

PIN 1 →

2.7.2. Front Panel Power LED

The chassis Power LED connector can be connected to the four pin connector. When you turn your system on, this LED will also be turned on.

PIN 1 →

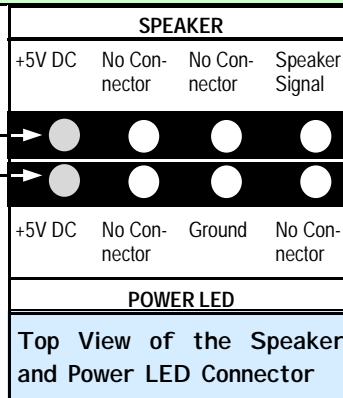

2.8. External Connectors

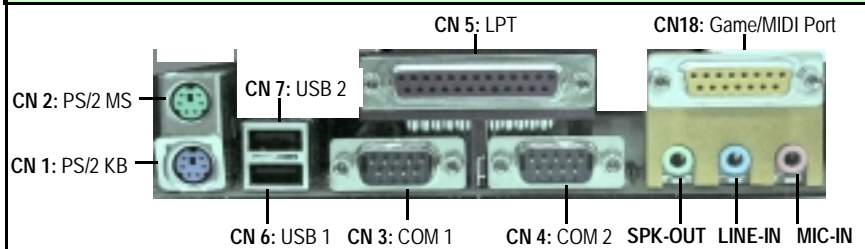

2.8.1. PS/2 Keyboard connector.

Connector: CN 1
Type: 6 pin female

This connector only supports a PS/2 keyboard plug. If you have a standard AT size (large DIN) keyboard plug, you need to use a mini DIN adapter.

2.8.2. PS/2 Mouse connector.

Connector: CN 2
Type: 6 pin female.

This connector only supports a PS/2 mouse plug. If a PS/2 mouse is detected then IRQ 12 will be directed to **CN 2**.

2.8.3. Serial Port 1 (COM 1) and Serial Port 2 (COM 2)

Connector: CN 3 (COM 1)/ CN 4 (COM 2)
Type: 9 pin male/9 pin male

One serial port is available for a mouse and other serial devices. (I/O addresses used are 3F8H/2F8H/3E8H/2E8H and IRQ3/IRQ4, selected by CMOS setup.)

2.8.4. Parallel Port Connector

Connector: CN 5
Type: 25 pin female.

This parallel port is used by printers which support the SPP, EPP and ECP modes IRQ7 or IRQ5 can be selected. The ECP mode will use either DMA 3 or DMA 1 (which can be selected by the BIOS setup program).



2.8.5. Universal Serial Bus (USB) Port 1 & 2

Connector: CN 6 (USB 1)/ CN 7 (USB 2)
Type: 4 pin female

Two USB ports are available for connecting USB devices. The mainboard is also equipped with an expansion connector that supports two additional USB external connectors. (The USB cable is not included with the mainboard).

2.8.6. Audio/Game Port Connector

Connector: CN 18
Type: 15 pin female

The Game/MIDI port connector is a dual purpose connector. It can either be used to connect a joystick to the computer for game participation, or it can be used to attach an external MIDI device. All these motherboards have 3D audio interfaces onboard.

2.9. Jumper Settings

Jumpers are built on the mainboard to allow the user flexibility to configure the mainboard settings to meet their specific requirements. The 366 mainboard series come with 5 jumpers, three 3-pin and two 2-pin jumpers. When there is no jumper cap inserted into the jumper it is called "OPEN." When a cap is inserted into the jumper it is known as a "SHORT." Below is an example of a short setting on a jumper.

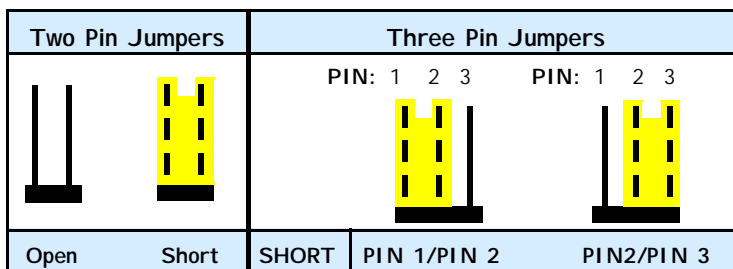

2.9.1. JP1: USB 1 and USB 2 power

Type: 3 pin
Default: Pin 1 and Pin 2 Short

This jumper allows you to select the voltage that is supplied to USB 1 and USB 2. You have two choices: 5 V (pin 1 and pin 2 short) or standby 5 V (pin 2 and pin 3 short). Some USB devices may not follow the standard USB power specifications. If you are using such a device it may unstable. If you do experience problems try to change the setting on JP 1. This might help solve this problem.



2.9.2. JP2: Keyboard Power

Type: 3 pin
Default: Pin 1 and Pin 2 Short

Some keyboards may not follow standard specifications. If you find you are having problems with your keyboard, change the settings on JP 2. This might help you to solve the problem.

2.9.3. JP6: CPU Clock

Type: 2 pin
Default: Open

This allows you to select the speed of your CPU. If you are using a 200 MHz CPU (with a 100 MHz FSB) on your mainboard then you need to SHORT JP 6. If you are using a 266 MHz CPU (with a 133 MHz FSB) you need to OPEN JP6.

2.9.4. JP8: Clear CMOS Memory

Type: 3 pin
Default: Pin 1 and Pin 2 Short

If you have made an improper setting in the BIOS setup and your computer is not functioning, or if you have forgotten your password, you can use this jumper, JP 8, to clear the CMOS memory and to reconfigure your system.

To clear the CMOS, please follow these instructions:

1. Turn the system power "OFF" and unplug your computer.
2. Insert the jumper cap on Pin 2 and Pin 3 for 3 ~ 5 seconds.
3. Pull out the jumper cap and replace it on Pin 1 and Pin 2.
5. Turn your PC on and run the BIOS setup program

2.10. DIP Switch (only available for 366X-AS)

These mainboards are all fitted with a single switch, **SW1**. On this switch there are five toggle switches that you can select as **OFF** or **ON**. The default has all the toggle switches set to **OFF**. If you toggle any of these switches to **ON**, you will alter the processing speed of your CPU. The increase in the processing speed is a multiple of the original processing speed. The table on **page 25** shows the different combinations of the toggle switches and the multiple increase in the processing speed.



Hardware Installation



For example, if I set the switches in the following configuration (see diagram below):

- SW 1: OFF
- SW 2: ON
- SW 3: OFF
- SW 4: ON
- SW 5: ON



The processing speed would be 5.5 times faster than the original CPU speed.

You do not need to change the switch settings from the default. If you retain the default settings your system will run smoothly.

DIP Switch Settings					
Ratio	Switch 1	Switch 2	Switch 3	Switch 4	Switch 5
Default	OFF	OFF	OFF	OFF	OFF
5 (14)	ON	ON	OFF	ON	ON
5.5	OFF	ON	OFF	ON	ON
6	ON	OFF	OFF	ON	ON
6.5	OFF	OFF	OFF	ON	ON
7	ON	ON	ON	OFF	ON
7.5	OFF	ON	ON	OFF	ON
8	ON	OFF	ON	OFF	ON
8.5	OFF	OFF	ON	OFF	ON
9	ON	ON	OFF	OFF	ON
9.5	OFF	ON	OFF	OFF	ON
10	ON	OFF	OFF	OFF	ON
10.5	OFF	OFF	OFF	OFF	ON
11	ON	ON	ON	ON	ON
11.5	OFF	ON	ON	ON	ON
12	ON	OFF	ON	ON	ON
12.5 (13)	OFF	OFF	ON	ON	ON



Chapter 3 - Managing the PC BIOS

3.1. Award BIOS CMOS Setup Utility

Once you have installed the mainboard you still need to setup the BIOS before you can run your PC. The EEPROM on the mainboard stores the AWARD BIOS CMOS Setup Utility, which allows you to configure your system. When you want to configure or make any changes to the configuration of your system BIOS you must run the BIOS CMOS Setup Utility.

GETTING STARTED

Every time you start your computer, the system provides you with an opportunity to run the BIOS CMOS Setup Utility. As soon as you turn on your system, press the <Delete> button to activate the BIOS CMOS Setup Utility.

If your computer finishes the POST (Power-On-Self-Test) the BIOS CMOS Setup Utility will **not be** activated. If your computer completes the POST you need to restart the system to activate the BIOS CMOS Setup Utility. To restart the system, you can either turn the power off, press the reset button on your chassis or press the <Ctrl> + <Alt> + <Delete> button. In all three cases the system will restart and, to activate the BIOS CMOS Setup Utility, you must immediately press the <Delete> button.

3.2. Main Menu



Once you have called up the BIOS CMOS Setup Utility, the following screen will appear:

CMOS Setup Utility – Copyright (C) 1984 - 2001 Award Software	
<ul style="list-style-type: none"> ▶ Standard CMOS Features ▶ Advanced BIOS Features ▶ Advanced Chipset Features ▶ Integrated Peripherals ▶ Power Management Setup ▶ PNP/PCI Configuration ▶ PC Health Status 	<ul style="list-style-type: none"> ▶ Frequency/Voltage Control Load Optimized Defaults Set Supervisor Password Set User Password Save & Exit Setup Exit Without Saving
Esc : Quit F10 : Save and Exit Setup	← ↑ ↓ → : Select Item
Time, Date, Hard Disk Type ...	

Note! BIOS software is continuously updated therefore the BIOS menus and the descriptions that are given in this manual are for reference purposes only.



Navigation Keys

You will notice a legend bar at the bottom of the main menu. The keys in this legend bar show you how to navigate through the setup menus. The table below lists the control keys with their corresponding functions: -

Control Key	Function
Up Arrow	Moves to the previous item.
Down Arrow	Moves to the next item.
Left Arrow	Moves to the item on the left.
Right Arrow	Moves to the item on the right.
Enter	Selects the desired item.
F1	Displays the help screen for the selected feature.
Esc key	Exits to the previous screen.
PgUp(-)/PgDn(+)	Modifies or changes the content of the highlighted item.
F5	Restores the previous CMOS values to the current page setup. This will not restore the previous values for any other pages.
F7	Loads the SETUP default values from BIOS default table, (only the current page setup will be loaded).
F10	Saves changes to the CMOS and exits the setup.

3.3. Standard CMOS Setup *(This menu is on page 28)*



Date (mm : dd : yy)

Sets your system to the date that you specify (usually the current date). The format is month, day, and year. Press the right or left arrow key to move to the desired field (month, date, year). Press the PgUp or PgDn key to increment the setting, or type the desired value into the field.

Time (hh : mm : ss)

Sets your system to the time you specify (usually the current time). The format is hour, minute, second. The time format is based on the 24-hour military-time clock. For example, 1 p.m. is 13:00:00. Press the right or left arrow key to move to the desired field. Press the PgUp or PgDn key to increment the setting, or type the desired value into the field.

IDE Primary / Secondary Master / Slave

This mainboard supports four IDE Hard Drives. These fields allow you to set your Hard Drive parameters. Move the selection bar to the IDE Hard Drive you want to configure. Press the "ENTER" key. If you select "AUTO" the system BIOS will detect the HDD type automatically.



Managing The PC BIOS



CMOS Setup Utility - Copyright (C) 1984 - 2001 Award Software Standard CMOS Features		
Date (mm : dd : yy)	Tue, October 30, 2001	Item Help
Time (hh : mm : ss)	13 : 39 : 52	
▶ IDE Primary Master	[QUANTUM FIREBALL	Menu Level ▶ Change the day, month, year and century
▶ IDE Primary Slave	PKA]	
▶ IDE Secondary Master	Press Enter None	
▶ IDE Secondary Slave	Press Enter None	
Drive A	Press Enter None	
Drive B	1.44, 3.5 in	
Video	None	
Halt On	EGA/VGA	
Base Memory	All Errors	
Extended Memory	640K	
Total Memory	130048K	
	131072K	

Drive A / B

The 366 mainboard series can support up to two floppy disk drives. These two selection fields allow you to select the floppy drives that are installed on your computer. Select the

Diskette Drive	Type of Disk Drive	Capacity
None	No diskette drive installed	
360K 5.25 in	5-1/4 inch PC-type standard drive	360 KB
1.2M 5.25 in	5-1/4 inch AT-type high-density drive	1.2 MB
720K 3.5 in	3-1/2 inch single-sided drive	720 KB
1.44M 3.5 in	3-1/2 inch double-sided drive	1.44 MB
2.88M 3.5 in	3-1/2 inch double-sided drive	2.88 MB

Video

This field selects the type of primary video subsystem that is on your computer. The BIOS CMOS Setup Utility will automatically detect the correct video type.

Monitors	
EGA/VGA	Enhanced Graphics Adapter/Video Graphics Array. For EGA, VGA, SEGA, SVGA or PGA monitor adapters
CGA 40	Color Graphics Adapter power up in 40 column mode
CGA 80	Color Graphics Adapter power up in 80 column mode
MONO	Monochrome adapter includes high resolution monochrome adapters



Halt On

This field allows you to decide which errors, detected during the Power On Self Test (POST), will halt the system.

Base Memory / Extended Memory / Total Memory

This field displays the amount of memory detected by the system during boot up. This is a display only field. You cannot make any changes to this field.

Base Memory: Indicates the memory installed below the conventional 1MB space.

Extended Memory: Indicates the memory installed above the 1MB space.

Total Memory: Indicates the total memory installed in the PC system.

3.4. Advanced BIOS Features *(This menu is on page 30)*



Virus Warning

When you enable the virus warning you will receive a warning message whenever a program (specifically, a virus) attempts to write to the boot sector or the partition table of the hard disk drive. If you receive such a message you should immediately run an anti-virus program. Keep in mind that this feature **only** protects the boot sector and not the entire hard drive.

Disk diagnostic programs that access the boot sector table can trigger the virus-warning message. If you run such a program, recommend that you first disable the virus warning.

CPU Internal Cache / External Cache

Cache memory is additional memory that is much faster than conventional DRAM (system memory). CPUs from 486-type up contain internal cache memory, and most, but not all, modern PCs have an additional (external) cache memory. When the CPU requests data, the system transfers the requested data from the main DRAM into cache memory, for faster access by the CPU.

CPU L2 Cache ECC Checking

When you select Enabled, the ECC checking will ensure that the data stored on the L2 cache is accurate.

Quick Power On Self Test

If enabled the amount of time required to run the power-on self-test (POST) will decrease. A quick POST skips certain steps. We recommend that you disable quick POST. It is better to find a problem during POST than to lose data during your work.



Managing The PC BIOS



CMOS Setup Utility - Copyright (C) 1984 – 2001 Award Software.
Advanced BIOS Features

Virus Warning	[Disabled]	Item Help
CPU Internal Cache	[Enabled]	
External Cache	[Enabled]	Menu Level ▶ Allows you to choose the VIRUS warning feature for IDE Hard disk boot sector protection. If this function is enabled and someone attempts to write data into this area, BIOS will show a warning message on screen and alarm beep.
CPU L2 Cache ECC Checking	[Enabled]	
Quick Power On Self Test	[Enabled]	
First Boot Device	[Floppy]	
Second Boot Device	[HDD-0]	
Third Boot Device	[LS120]	
Boot Other Device	[Enabled]	
Swap Floppy Drive	[Disabled]	
Boot Up Floppy Seek	[Enabled]	
Boot Up NumLock Status	[On]	
Gate A20 Option	[Fast]	
Typematic Rate Setting	[Disabled]	
X Typematic Rate (Chars/Sec)	6	
X Typematic Delay (Msec)	250	
Security Option	[Setup]	
PS/2 Mouse Function Control	[Enabled]	
OS Select For DRAM > 64 MB	[Non-OS2]	
HDD S.M.A.R.T. Capability	[Disabled]	
Video BIOS Shadow	[Enabled]	

First / Second / Third Boot Device

These fields allow you to decide the boot sequence of your bootable devices such as Floppy Drive, Hard Drive, CD ROM...etc

Boot Other Device

When this field is enabled you will be able Boot your computer from a another device, not your HDD or FDD.

Swap Floppy Drive

This field is effective only in systems with two floppy drives. When Enabled is selected physical drive B is assigned to logical drive A, and physical drive A is assigned to logical drive B.

Boot Up Floppy Seek

When enabled, the BIOS tests (seeks) floppy drives to determine whether they have 40 or 80 tracks. Only 360-KB floppy drives have 40 tracks; drives with 720 KB, 1.2 MB, and 1.44 MB capacity all have 80 tracks. Very few modern PCs have 40-track floppy drives so we therefore recommend that you set this field to Disabled to save time.



Boot Up NumLock Status

This controls the state of the NumLock key when the system boots. This field is toggled between On or Off. When it is on the numeric keypad generates numbers instead of controlling the cursor operations. When it is off the numeric keypad controls cursor operations and does not generate numbers.

Gate A20 Option

Gate A20 is a signal that gives the system access to addresses higher than A19. If you select Fast the chipset will control this signal. If you select normal a pin in the keyboard controller will control the signal.

Typematic Rate Setting

The keyboard controller determines the rate at which the keystrokes from the keyboard are repeated. If you enable this option then the typematic rate and the typematic delay can be selected.

Typematic Rate

This is the rate a character will repeat itself on the screen when you hold down a key.

Typematic Delay

This is the delay time (Msec) before the repetition of characters starts.

Security Option

This field allows you to select the "Setup" or "System" security option. It works concurrently with the " Set Supervisor Password" in the main menu.

When the "Setup" option is selected, you will be prompted to enter your "Password" before you can start the BIOS CMOS Setup Utility. When you select "System" option, you will be prompted to enter your password in order to load the Operating System.

TIP: Forgot your password then clear the RTC RAM

If you happen to forget your password you can use Jumper 2 (JP8) to clear the password by erasing the CMOS Real Time Clock (RTC) Ram. Please see section 2.9.4 on page 24.

OS Select For DRAM > 64MB

Only select OS2 if you are running an OS/2 operating system with a RAM greater than 64 Mb. Otherwise, for all other operating systems, use the default setting "Non-OS2"

PS/2 Mouse Function Control

If you have installed a serial pointing device and your system has a PS/2 mouse port you should disable this option.



Managing The PC BIOS



HDD S.M.A.R.T Capability

(Using this feature may decrease system performance)

You may "enable" this option if your Hard Drive supports the S.M.A.R.T. technology (Self Monitoring Analysis Reporting Technology) feature. S.M.A.R.T. will monitor and report your Hard Drive health status. Ask your Hard Drive Vendor for further information.

Video BIOS Shadow

These fields allow you to change the Video BIOS location from ROM to RAM. Information access is faster through RAM than ROM. Therefore when you enable this option you will enhance your system performance.

3.5. Advanced Chipset Features

CMOS Setup Utility - Copyright (C) 1984 - 2001 Award Software Advanced Chipset Features		
▶ DRAM Clock/Drive Control	[Press Enter]	Item Help
▶ AGP & P2P Bridge Control	[Press Enter]	Menu Level ▶
▶ CPU & PCI Bus Control	[Press Enter]	
Memory Hole	[Disabled]	
System BIOS Cacheable	[Disabled]	
Video RAM Cacheable	[Disabled]	

Dram Clock Drive Control

This field allows you to select the FSB and DRAM frequency. When you press enter the following menu will appear.

CMOS Setup Utility - Copyright (C) 1984 - 2001 Award Software DRAM Clock/Drive Control		
Current FSB Frequency	100 MHz	Item Help
Current DRAM Frequency	133 MHz	Menu Level ▶ ▶
DRAM Clock	[By SPD]	
DRAM Timing	[By SPD]	
X SDRAM Cycle Length	2.5	
X Bank Interleave	Disabled	
X Precharge to Active (Trp)	3T	
X Active to Precharge (Tras)	6T	
X Active to CMD (Trcd)	3T	
DRAM Command Rate	[2T Command]	

▶ Current FSB Frequency

The setting for this field will be automatically selected by the BIOS. The value that the BIOS selects depends on the settings you have chosen for JP6. If you have a 100 MHz CPU but have and set JP6 to OPEN the BIOS will detect 133 MHz.



Managing The PC BIOS



▸ Current Dram Frequency

The setting for this field will be automatically detected by the BIOS. The value that is selected is derived from the RAM clock.

▸ DRAM Clock

When you select **By SPD** The following menu will pop up:

- 100 MHz
- 133 MHz
- By SPD

If you select **100 MHz** the DRAM clock speed will be PC1600 (100 MHz DDR). If you select **133 MHz** the DRAM clock speed will be PC2100 (133 MHz DDR). If you select **By SPD** the BIOS will automatically detect the actual DRAM Clock.

▸ DRAM Timing

This field determines the DRAM read/write timing. The performance parameters of the memory chips (DRAM) you have installed will determine the value in this field. Do not change the value from the factory setting unless you install new memory that has a different performance rating than the original DRAMs.

▸ SDRAM Cycle Length

Before SDRAM can execute a read command that it receives, there is a delay time, which is measured in clock cycles (CLK). The lower the delay time the faster the execution of commands will be. It is therefore desirable to minimize this cycle length. Some memory modules are unable to deal with short delay times. We recommend that you set this delay time between 2.5 and 3 CLK's (the default is 2.5). If your system becomes unstable we recommend that you increase the delay time.

AGP & P2P Bridge Control

When you press enter the following menu will appear:

CMOS Setup Utility - Copyright (C) 1984 - 2001 Award Software AGP & P2P Bridge Control		
AGP Aperture Size	[64M]	Item Help
AGP Mode	[2X]	Menu Level ▶▶
AGP Driving Control	[Auto]	
X AGP Driving Value	DA	
AGP Fast Write	[Disabled]	
AGP Master 1 WS Write	[Disabled]	
AGP Master 1 WS Read	[Disabled]	

▸ AGP Aperture Size

This field selects the size of the Accelerated Graphics Port (AGP) aperture. The aperture is a portion of the PCI memory address range dedicated for graphics memory address space. Host cycles that hit the aperture range are forwarded to the AGP without any translation. The default is 64MB. You may increase this memory when you need to have faster access for 3D graphics applications (e.g. games).



Managing The PC BIOS



▶ AGP Mode

This item allows you to select 1x, 2x or 4x AGP mode.

▶ AGP Driving Control

The recommended setting for this field is the default "Auto". If you have an unstable AGP card you may use this field to choose the appropriate settings. If you do need to tune the timing, please consult your AGP Card manual or Vendor.

▶ AGP Driving Value

This item allows you to adjust the AGP driving force.

▶ AGP Fast Write

Some AGP cards, like G-Force, support AGP fast write. If you have an AGP card that supports this mode you can enable this field. If your AGP card does not support the fast write mode then leave this field "disabled".

▶ AGP Master 1 WS Write

When Enabled, writes to the AGP are executed with one-wait states.

▶ AGP Master 1 WS Read

When Enabled, reads to the AGP are executed with one-wait states.

CPU & PCI Bus Control

When you select this field the following menu will appear:

CMOS Setup Utility - Copyright (C) 1984 - 2001 Award Software CPU & PCI Bus Control		
PCI1 Master 0 WS Write	[Enabled]	Item Help
PCI2 Master 0 WS Write	[Enabled]	Menu Level ▶▶
PCI1 Post Write	[Enabled]	
PCI2 Post Write	[Enabled]	
PCI Delay Transaction	[Disabled]	

▶ PCI1/PCI2 Master 0 WS Write

When enabled, writes to the PCI 1/PCI 2 bus are executed with zero wait states.

▶ PCI1/PCI2 Post Write

You can Enable or Disable the chipset's ability to use a buffer for posted writes initiated on the PCI 1/PCI 2 bus.

▶ PCI Delay Transaction

The chipset has an embedded 32-bit posted write buffer to support delay transactions cycles. Select Enabled to support compliance with PCI specification version 2.1.

Memory Hole

You can reserve this area of system memory for ISA adapter ROM. When this area is reserved, it cannot be cached. The user information of peripherals that need to use this area of system memory usually discusses their memory requirements.



Managing The PC BIOS



System BIOS Cacheable

Selecting "Enabled" allows caching of the system BIOS ROM. This results system performance. However, if any program writes to this memory area, a system error may occur.

Video RAM Cacheable

Select Enabled allows caching of the video RAM, resulting in better system performance. However, if any program writes to this memory area, a system error may occur.

3.6. Integrated Peripherals

CMOS Setup Utility - Copyright (C) 1984 - 2001 Award Software Integrated Peripherals		
▶ VIA OnChip IDE Device	[Press Enter]	Item Help
▶ VIA OnChip PCI Device	[Press Enter]	Menu Level ▶
▶ SuperIO Device	[Press Enter]	
Init Display First	[PCI Slot]	
OnChip USB Controller	[All Enabled]	
USB Keyboard Support	[Disabled]	
IDE HDD Block Mode	[Enabled]	

VIA OnChip IDE Device

When you press enter the following menu will appear:

CMOS Setup Utility - Copyright (C) 1984 - 2001 Award Software VIA OnChip IDE Device		
OnChip IDE Channel0	[Enabled]	Item Help
OnChip IDE Channel1	[Enabled]	Menu Level ▶
IDE Prefetch Mode	[Enabled]	
Primary Master PIO	[Auto]	
Primary Slave PIO	[Auto]	
Secondary MasterPIO	[Auto]	
Secondary Slave PIO	[Auto]	
Primary Master UDMA	[Auto]	
Primary Slave UDMA	[Auto]	
Secondary MasterUDMA	[Auto]	
Secondary Slave UDMA	[Auto]	



Managing The PC BIOS



▶ OnChip IDE Channel 0/1

The chipset contains a PCI IDE interface with support for two IDE channels. To activate the primary IDE interface select Enabled. If you want to disable the onboard IDE 1 and/or 2, then select Disabled and this interface will be deactivated.

▶ OnChip IDE Channel 0/1

The chipset contains a PCI IDE interface with support for two IDE channels. To activate the primary IDE interface select Enabled. If you want to disable the onboard IDE 1 and/or 2, then select Disabled and this interface will be deactivated.

▶ IDE Prefetch Mode

The onboard IDE drive interfaces supports IDE pre-fetching for faster drive access. If you install a primary and/or secondary add-in IDE interface which does not support pre-fetching set this field to Disabled.

▶ Primary/Secondary, Master/Slave PIO

The four IDE PIO (Programmed Input/Output) fields let you set a PIO mode (0-4) for each of the four IDE devices that the onboard IDE interface supports. Modes 0 through 4 provide successively increased performance. In Auto mode, the system automatically determines the best mode for each device.

▶ Primary/Secondary, Master/Slave UDMA

Ultra DMA/66 implementation is possible only if your IDE hard drive supports it and the operating environment includes a DMA driver (Windows 98 OSR2 or a third-party IDE bus master driver). If your hard drive and your system software both support Ultra DMA/66, select Auto to enable BIOS support.

VIA OnChip PCI Device

When you select this field the following menu will appear:

CMOS Setup Utility - Copyright (C) 1984 - 2001 Award Software VIA OnChip PCI Device		
VIA-3058 AC97 Audio	[Auto]	
VIA-3068 MC97 Modem	[Auto]	Menu Level ▶▶

▶ VIA-3058 AC97 Audio

If you want to enable the on-chip audio capabilities of your system you need use the default setting "Auto". If you install an add on sound card you must disable this field.

▶ VIA-3068 MC97 Modem

This chipset can support MC97 Modem. This field allows you to decide whether you want this support or not. If you select "Auto" the BIOS will automatically detect the AC97. If you select "Disabled" the Bios will not detect any support for the AC97 audio/modem.



Managing The PC BIOS



SuperIO Device

When you press enter the menu **below** is shown:

CMOS Setup Utility - Copyright (C) 1984 - 2001 Award Software SuperIO Device		
Onboard FDC Controller	[Enabled]	Item Help
Onboard Serial Port 1	[3F8/IRQ4]	Menu Level ▶▶
Onboard Serial Port 2	[2F8/IRQ3]	
UART Mode Select	[Normal]	
X RxD, TxD Active	Hi, Lo	
X IR Transmission Delay	Enabled	
X UR2 Duplex Mode	Half	
X Use IR Pins	IR-Rx2Tx2	
Onboard Parallel Port	[378/IRQ7]	
Parallel Port Mode	[SPP]	
X EPP Mode Select	EPP1.7	
X ECP Mode Use DMA	3	
Game Port Address	[201]	
Midi Port Address	[330]	
Midi Port IRQ	[10]	

▶ Onboard FDC Controller

Select Enabled if your system has a floppy disk controller (FDC) installed on the system board and you want to use it. If you install an add-in FDC or the system has no floppy drive, select Disabled in this field.

▶ Onboard Serial Port 1/Port 2

These two selection fields allow you to select the I/O address and corresponding interrupts for the first and second serial ports.

▶ UART Mode Select

Your system may offer a variety of infrared modes on the second serial port. The options are Standard, HPSIR or ASKIR.

▶ UART Mode Select

Your system may offer a variety of infrared modes on the second serial port. The options are Standard, HPSIR or ASKIR.

▶ RxD, TxD Active

This field allows you to set the IR reception/transmission polarity as high or low. To determine which polarity is appropriate you must refer to the documentation for your IR peripheral.

This field is usually found under the Onboard Serial Port 2 option. If you disable the



Managing The PC BIOS



▸ IR Transmission Delay

This field allows you to "Enable" or "Disable" the IR Transmission Delay.

▸ UR2 Duplex Mode

This field appears in an infrared port mode. You have two options: half or full duplex function. The full duplex mode allows bi-directional transmission at a single time where as the half duplex mode only allows transmission in one direction at a time. This setting depends on the nature of your IR peripheral device. Check the IR device's manual to determine the appropriate setting.

▸ Use IR Pins

To determine the correct settings for the TxD and RxD signals of your IR peripheral component, you need to consult the components manual.

▸ Onboard Parallel Port

This item allows you to determine the I/O address and the IRQ for the onboard parallel port. The default settings are adequate and should not give you any problems. If they do you can try to change them.

▸ Onboard Parallel Mode

This field allows you to select an operating mode for the onboard parallel (printer) port. Select Normal, Compatible, or SPP unless you are certain your hardware and software both support one of the other available modes.

▸ EPP Mode Select

This field allows you to choose the EPP version you want to use. We recommend that you use EPP 1.9 for the best performance but if you do you may have some connection problems so try setting it to EPP 1.7.

▸ ECP Mode Use DMA

This item allows you to select a DMA channel for the parallel port for use during ECP.

▸ Game Port Address

This field allows you to select the I/O address for the onboard game port. The default is 201.

▸ Midi Port Address

This field allows you to select the I/O address for the onboard MIDI port. The default is 330.

▸ MIDI Port IRQ

This field allows you to select the IRQ for the onboard MIDI port. The default is 10.

Init Display First

This field allows a user, with two graphics cards installed on his system, to select which graphics card will be activated first: either the PCI graphics card or the AGP graphics card. If you have only installed one graphics card the BIOS will automatically detect it and you do not need to set this field.



Managing The PC BIOS



OnChip USB Controller

This field allows you to enable or disable the onboard USB controller.

USB Keyboard Support

This field should only be enabled if you are using a USB keyboard. If you are not using this kind of keyboard you should disable it.

IDE HDD Block Mode

Block mode is also known as block transfer, multiple commands, or multiple sector read/write. If your IDE hard drive supports block mode select "Enabled" for automatic detection of the optimal number of block read/writes per sector the drive can support.

3.7. Power Management Setup

CMOS Setup Utility - Copyright (C) 1984 - 2001 Award Software Power Management Setup		
ACPI Function	[Enabled]	Item Help
ACPI Suspend Type	[S1 (POS)]	Menu Level ▶
Power Management	[User Define]	
Suspend Mode	[Disable]	
Video Off Option	[Disable]	
Video Off Method	[Suspend -> Off]	
MODEM Use IRQ	[Blank Screen]	
Soft-Off by PWRBTN	[3]	
▶ IRQ/Event Activity Detect	[Instant-Off]	

ACPI function

This item allows you to enable/disable the Advanced Configuration and Power Management (ACPI).

ACPI Suspend Type

This field allows you to select the mode of the suspended state. You have two options: **S1(POS)**: Power On Suspend or **S3(STR)**: Suspend to Ram.

Power Management

This category allows you to select the degree of power saving. The choices are shown in the table at the top of page 40.



Managing The PC BIOS



Min. Power Saving	Minimum power management. Suspend Mode = 1 hr.
Max. Power Saving	Maximum power management -- ONLY AVAILABLE FOR SL CPU. Suspend Mode = 1 min.
User Defined	Allows you to set each mode individually. When not disabled, each of the ranges are from 1 min. to 1 hr. except for HDD Power Down which ranges from 1 min. to 15 min. and disable.

HDD Power Down

When enabled and after the set time of system inactivity, the hard disk drive will be powered down while all other devices remain active.

Suspend Mode

When enabled, after the set time of system inactivity, all devices except the CPU will be shut off.

Video Off Option

When enabled, this feature allows the VGA adapter to operate in a power saving mode.

Always On	Monitor will remain on during power saving modes.
Suspend --> Off	Monitor blanked when the systems enters the Suspend mode.
All Modes --> Off	Monitor blanked when the system enters any power saving mode.

Video Off Method

This determines the manner in which the monitor goes blank.

V/H SYNC+Blank	This selection will cause the system to turn off the vertical and horizontal synchronization ports and write blanks to the video buffer.
Blank Screen	This option only writes blanks to the video buffer.
DPMS Support	Select this option if your monitor supports the Display Power Management Signaling (DPMS) standard of the Video Electronics Standards to select video power management values.

MODEM Use IRQ

This determines the IRQ which the MODEM can use for power saving purposes. This mainboard has the ACPI feature designed on the board and it will "wakeup" automatically when it detects an incoming modem Ring-in signal. Before you can use the Ring-in signal to wakeup your PC system, you have to install the "External" modem to your PC system and tell the PC system which serial port connects to the modem by selecting the IRQ in this field, (officially, COM 1 uses IRQ4, and COM 2 uses IRQ3)



Managing The PC BIOS



Soft-Off by PWRBTN

Pressing the power button for more than 4 seconds forces the system to enter the Soft-Off state when the system has "hung".

IRQ/Event Activity Detect

When press the "Enter" key on this selection field, the following menu will appear:

CMOS Setup Utility - Copyright (C) 1984 - 2001 Award Software Wake-Up Events		
VGA	[OFF]	Item Help
LPT & COM	[LPT/COM]	Menu Level ▶
HDD & FDD	[ON]	
PCI Master	[OFF]	
PowerOn by PCI Card	[Disabled]	
Modem Ring Resume	[Disabled]	
RTC Alarm Resume	[Disabled]	
X Date (of Month)	0	
X Resume Time (hh : mm : ss)	0 0 0	
IRQs Activity Monitoring	[Press Enter]	

▶ VGA

When you enable this option, any VGA signal will wake up the system.

▶ LPT & COM

When this field is "ON" any activity from these devices, or their IRQ's will wake up the system.

▶ HDD & FDD

When this field is "ON" any activity from the HDD or the FDD will wake up the system.

▶ PCI Master

When you enable the PCI Master mode, any activity from one of the listed system peripheral devices wakes up the system.

▶ Power On by PCI Card

The system can be woken up by the PME# on the PCI card.

▶ Modem Ring Resume

An input signal from the modem/LAN will wake up the system from a soft off state.

▶ RTC Alarm Resume

When enabled, you can use the following two fields to select the time and date to wake up the PC system from power saving mode.



Managing The PC BIOS



▸ Date (of Month)/Resume Time (hh:mm:ss)

When RTC Alarm Resume is enabled, you can set the date and time at which the RTC (real-time clock) alarm awakens the system from Suspend mode.

▸ IRQs Activity Monitoring

The following is a list of IRQ's, Interrupt ReQuests, which can be exempted much as the COM ports and LPT ports above can. When an I/O device wants to gain the attention of the operating system, it signals this by causing an IRQ to occur. When the operating system is ready to respond to the request, it interrupts itself and performs the service.

CMOS Setup Utility - Copyright (C) 1984 - 2001 Award Software IRQs Activity Monitoring			
Primary INTR	[ON]	Item Help	
IRQ3 (COM 2)	[Enabled]	Menu Level >>>	
IRQ4 (COM 1)	[Enabled]		
IRQ5 (LPT 2)	[Enabled]		
IRQ6 (Floppy Disk)	[Enabled]		
IRQ7 (LPT 1)	[Enabled]		
IRQ8 (RTC Alarm)	[Disabled]		
IRQ9 (IRQ2 Redir)	[Disabled]		
IRQ10 (Reserved)	[Disabled]		
IRQ11 (Reserved)	[Disabled]		
IRQ12 (PS/2 Mouse)	[Enabled]		
IRQ13 (Coprocessor)	[Enabled]		
IRQ14 (Hard Disk)	[Enabled]		
IRQ15 (Reserved)	[Disabled]		
Note: When set On, activity will neither prevent the system from going into a power management mode nor awaken it.			

3.8. PNP/PCI CONFIGURATION

CMOS Setup Utility - Copyright (C) 1984 - 2001 Award Software PNP/PCI Configurations		
PnP OS Installed	[No]	Item Help
Reset Configuration Data	[Disabled]	Menu Level > Select Yes if you are using a Plug and Play capable operating system. Select No if you need the BIOS to configure non-boot devices.
Resources Controlled By	[Auto (ESCD)]	
PCI/VGA Palette Snoop	[Disabled]	
Assign IRQ For VGA	[Enabled]	
Assign IRQ For USB	[Enabled]	



PNP OS Installed

This item allows you to determine if a PnP OS is installed or not.

Reset Configuration Data

Normally, you leave this field Disabled. If you have installed a new add-on and the system reconfiguration has caused such a serious conflict that the operating system cannot boot then select Enabled. Selecting Enabled will reset the Extended System Configuration Data (ESCD).

Resources controlled By

Award Plug and Play BIOS has the capacity to automatically configure all of the boot and Plug and Play compatible devices. However, this capability means absolutely nothing unless you are using a Plug and Play operating system such as Windows 98.

IRQ Resources

When resources are controlled manually, assign each system interrupt a type, depending on the type of device using the interrupt

PCI/VGA Palette Snoop

Leave this field at *Disabled* all the time.

Assign IRQ For VGA/USB

A system's IRQs are limited. Sometimes you may need to use more IRQ signals for your add-on cards. BIOS allows you to disable the IRQ which is supposed to be connected to the VGA and USB ports. If you choose to disable the IRQ on the VGA or USB port, the IRQ will be released and becomes available for other devices. Please make sure that you have a USB or VGA adapter that does not need an IRQ before you select Disabled.

Assign IRQ For VGA/USB

A system's IRQs are limited. Sometimes you may need to use more IRQ signals for your add-on cards. BIOS allows you to disable the IRQ which is supposed to be connected to the VGA and USB ports. If you choose to disable the IRQ on the VGA or USB port, the IRQ will be released and becomes available for other devices. Please make sure that you have a USB or VGA adapter that does not need an IRQ before you select Disabled.

3.9. PC Health Status (menu on page 44)



CPU Warning Temperature

This field allows you to select an operating temperature range for your CPU. If the CPU temperature moves out of this range, any warning mechanism you have programmed into your system will be activated.



Managing The PC BIOS



CMOS Setup Utility - Copyright (C) 1984 - 2001 Award Software		
CPU Warning Temperature	[Disabled]	Item Help
Current CPU Temperature	55°C/131°F	Menu Level ►
Current CPU FAN Speed	4821 RPM	
Current CHASSIS FAN Speed	0 RPM	
Vcore (V)	1.74 V	
Vcc3 (V)	3.10 V	
+ 5 V	4.75 V	
+ 12 V	12.09 V	
- 12 V	-12.11 V	
VBAT (V)	2.99 V	
5VSB (V)	5.26 V	
Shutdown Temperature	[Disabled]	

Current CPU Temp.

This field shows the current temperature for CPU 1.

Current CPU FAN Speed

This field shows you the present CPU Cooling FAN1 speed.

Current Chassis FAN Speed

This field shows you the present CPU Cooling FAN2 speed.

Vcore

This field and the files below show you the current system voltage

Shutdown Temperature

When the system reaches a certain maximum temperature the system will automatically shutdown.

3.10. Frequency/Voltage Control

CMOS Setup Utility - Copyright (C) 1984 - 2001 Award Software Frequency/Voltage Control		
CPU Vcore Select	[Default]	Item Help
Auto Detect DIMM/PCI Clk	[Enabled]	Menu Level ►
Spread Spectrum	[Disabled]	
x Linear Spread Mode	2	
x Linear Spread Range	1	
CPU Clock	[100 MHz]	



Managing The PC BIOS



There is CMOS memory on the mainboard that can be used to store the system settings. If you don't know how to use the Award BIOS CMOS Setup Utility to select the settings, you may use this field to load the optimized defaults which are defined in the system BIOS. **Our engineer recommends the Optimized Defaults.** If this option is selected it will give a series of parameters that will ensure the reliability and performance of your PC.

If you lose your CMOS data or you don't know how to complete the setup procedure, you may use this option to load the Optimized default values from the BIOS default table.

If the CMOS data is corrupted, or if you selected some CMOS settings and find that the PC system becomes very unstable, you should try to load the optimized default values first and then re-configure the BIOS.

3.12. Set Supervisor Password

CMOS Setup Utility – Copyright (C) 1984 - 2001 Award Software	
<ul style="list-style-type: none"> ▶ Advanced BIOS Features ▶ Advanced BIOS Features ▶ Advanced Chipset Features ▶ Integrated Peripherals ▶ Power Management Setup ▶ PNP/PCI Configuration ▶ Health Status 	<ul style="list-style-type: none"> ▶ Frequency/Voltage Control Load Optimized Values <li style="background-color: #800000; color: white; padding: 2px;">Set Supervisor Password Set User Password Save & Exit Setup Exit Without Saving
ESC : Quit F10 : Save & Exit Setup	← ↑ ↓ → : Select Item
Load Optimized Defaults	

The "SUPERVISOR PASSWORD" is for you to control unauthorized access to your BIOS CMOS Setup or Booting into the your PC system. The Supervisor Password option is used together with the Security Option in section 3.5.

When "Setup" is selected in the Security Option:

If you want to change any BIOS setting, you will have to key-in the Supervisor Password so that you can start the BIOS CMOS Setup Utility and change the system setting.

When "System" is selected in Security Option:

Whenever you turn on the PC, it will request the user to enter the Password in order to boot up your system. Without the correct password, the PC system will stop and the operating system will not be loaded.



3.13. Set User Password

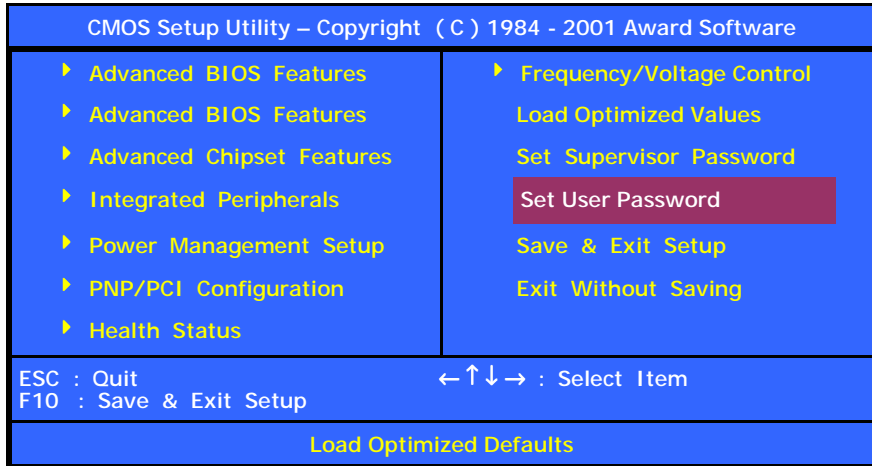

The User Password can be used to check the user's authority. However, this password entry is different from the "SUPERVISOR PASSWORD". The User Password has a different function to the "Supervisor Password" and the "Security Option" setup in Section 3.5:

A. When there is the password stored in the "SUPERVISOR PASSWORD"

1. When "Setup" is selected in the Security Option:

When you use the "User Password" to log into the BIOS setup program, you can only view the BIOS settings, but you cannot change any settings. The only setting you can change is the "User Password" and you can also select "SAVE & EXIT SETUP" and "EXIT WITHOUT SAVING" from the main menu. (If you use the Supervisor Password to log into the PC system, you will have the complete rights to all the BIOS settings.

2. When "System" is selected in Security Option:

When you turn on the PC system, it will request that you enter the Password. Without the correct password, the PC system will stop and the operating system won't be loaded.

B. When there is no password stored in the "SUPERVISOR PASSWORD"

1. When "Setup" is selected in Security Option:

Users can use the "User Password" to log into the BIOS setup program, and they can change any of the BIOS settings.

2. When "System" is selected in Security Option:

When you turn on your PC, you will be requested to enter the Password. Without the correct password, the PC system will stop and the operation system will not be loaded.



3.14. Save & Exit Setup/ Exit Without Saving

CMOS Setup Utility – Copyright (C) 1984 - 2001 Award Software	
<ul style="list-style-type: none">▶ Advanced BIOS Features▶ Advanced BIOS Features▶ Advanced Chipset Features▶ Integrated Peripherals▶ Power Management Setup▶ PNP/PCI Configuration▶ Health Status	<ul style="list-style-type: none">▶ Frequency/Voltage ControlLoad Optimized ValuesSet Supervisor PasswordSet User PasswordSave & Exit SetupExit Without Saving
ESC : Quit F10 : Save & Exit Setup	←↑↓→ : Select Item
Load Optimized Defaults	

Save & Exit Setup

This option will save all the setup values to CMOS RAM and exit the SETUP utility. Move the selection bar to "SAVE & EXIT SETUP" and press the "Enter" key, then type "Y" and press the "Enter" key again. The values you have entered will be saved and all the information stored in the CMOS memory.

Exit Without Saving

This option will exit the setup utility without saving any of the values you changed in the CMOS RAM. If you do not want to save any of the changes, or settings you selected in the BIOS SETUP utility, move the selection bar to the "EXIT WITHOUT SAVING" option. Press the "Enter" key. Then press "Y"