

---

---

## **Copyright and Warranty Notice**

---

The information in this document is subject to change without notice and does not represent a commitment on part of the vendor, who assumes no liability or responsibility for any errors that may appear in this manual.

No warranty or representation, either expressed or implied, is made with respect to the quality, accuracy or fitness for any particular part of this document. In no event shall the manufacturer be liable for direct, indirect, special, incidental or consequential damages arising from any defect or error in this manual or product.

Product names appearing in this manual are for identification purpose only and trademarks and product names or brand names appearing in this document are the property of their respective owners.

This document contains materials protected under International Copyright Laws. All rights reserved. No part of this manual may be reproduced, transmitted or transcribed without the expressed written permission of the manufacturer and authors of this manual.

If you do not properly set the motherboard settings, causing the motherboard to malfunction or fail, we cannot guarantee any responsibility.

---

---

---

---

---

---

---

---

# SD7-533 Motherboard User's Manual

## Index

---

<b>CHAPTER 1. INTRODUCTION OF SD7-533 FEATURES.....</b>	<b>1-1</b>
1-1. FEATURES OF SD7-533 MOTHERBOARD .....	1-1
1-2. SPECIFICATIONS.....	1-2
1-3. ITEM CHECKLIST .....	1-3
1-4. LAYOUT DIAGRAM FOR SD7-533 .....	1-4
<b>CHAPTER 2. INSTALLING THE MOTHERBOARD.....</b>	<b>2-1</b>
2-1. INSTALLING THE MOTHERBOARD TO THE CHASSIS .....	2-2
2-2. INSTALL PENTIUM® 4 PROCESSOR AND HEATSINK SUPPORTING-BASE.....	2-3
2-3. INSTALLING SYSTEM MEMORY .....	2-4
2-4. CONNECTORS, HEADERS AND SWITCHES.....	2-5
<b>CHAPTER 3. INTRODUCING THE BIOS .....</b>	<b>3-1</b>
3-1. SOFT MENU™ III SETUP .....	3-3
3-2. STANDARD CMOS FEATURES SETUP MENU .....	3-6
3-3. ADVANCED BIOS FEATURES SETUP MENU.....	3-9
3-4. ADVANCED CHIPSET FEATURES SETUP MENU .....	3-14
3-5. INTEGRATED PERIPHERALS .....	3-17
3-6. POWER MANAGEMENT SETUP MENU .....	3-23
3-7. PNP/PCI CONFIGURATIONS SETUP MENU .....	3-28
3-8. PC HEALTH STATUS .....	3-31
3-9. LOAD FAIL-SAFE DEFAULTS .....	3-32
3-10. LOAD OPTIMIZED DEFAULTS .....	3-32
3-11. SET PASSWORD.....	3-33
3-12. SAVE & EXIT SETUP .....	3-33
3-13. EXIT WITHOUT SAVING .....	3-33
<b>APPENDIX A. SIS CHIPSET DRIVERS INSTALLATION FOR WINDOWS®</b>	
<b>98 SE &amp; WINDOWS® 2000.....</b>	<b>A-1</b>
<b>APPENDIX B. INSTALLING THE WINBOND HARDWARE MONITOR</b>	
<b>SYSTEM.....</b>	<b>B-1</b>
<b>APPENDIX C. AUDIO DRIVERS AND APPLICATIONS INSTALLATION</b>	
<b>FOR WINDOWS® 98 SE &amp; WINDOWS® 2000.....</b>	<b>C-1</b>
<b>APPENDIX D. BIOS UPDATE GUIDE .....</b>	<b>D-1</b>
<b>APPENDIX E. TROUBLESHOOTING (NEED ASSISTANCE?) .....</b>	<b>E-1</b>
<b>APPENDIX F. HOW TO GET TECHNICAL SUPPORT.....</b>	<b>F-1</b>



---

## Chapter 1. Introduction of SD7-533 Features

---

### 1-1. Features of SD7-533 Motherboard

---

This motherboard is designed for use with Intel's latest generation of Pentium® 4 478 pins processors. Based on the new SiS 645 chipsets (SiS 645 & SiS 961), this motherboard supports 400 MHz system bus (100 MHz Quad Data Rate) and SiS MuTIOL® (Multi-threaded I/O Link) Technology connecting with SiS 961 MuTIOL® Media IO. The Intel® Pentium® 4 processors feature the new NetBurst Micro-architecture, which enriches the user experience in Net surfing and Multimedia activities.

The AGP interface can support an external AGP slot with AGP 1X/2X/4X capability and Fast Writes. A high bandwidth and mature SiS MuTIOL® technology is incorporated to connect the SiS 645 and SiS 961 MuTIOL® Media I/O together. SiS MuTIOL® technology is developed into three layers. The Multi-threaded I/O Link Layer delivers 1.2GB of bandwidth to connect embedded DMA Master devices and external PCI masters to interface with the Multi-threaded I/O Link layer, the Multi-threaded I/O Link Encoder/Decoder in the SiS 961 to transfer data with 533 MB/Sec of bandwidth to/from Multi-threaded I/O Link layer to/from SiS 645, and the Multi-threaded I/O Link Encoder/Decoder in SiS 645 to transfer data with 533 MB/Sec to/from the memory sub-system to/from the Multi-threaded I/O Link Encoder/Decoder in SiS 961.

The SiS 645 chipset used in this motherboard supports three DDR DIMMs for a maximum of up to 3 GB. The memory controller can support both DDR (up to DDR PC 2700, it running on 166 MHz and triggered by rising and falling edge) and SDR. It can offer bandwidth up to 2.7 GB/Sec under DDR 333 and 1 GB/Sec under PC 133 in order to sustain the bandwidth demand from the host processor, as well as the multi I/O masters and AGP masters. DDR SDRAM is the newest memory standard, and it provides maximum translation bandwidth and also greatly improves data transaction delays. This feature improves whole system performance and speed, especially in multimedia environment applications.

The SD7-533 has a built in Ultra DMA 100 function. This means that it provides speedier HDD throughput boosting overall system performance. Ultra DMA 100 is the new standard for IDE devices. It enhances existing Ultra DMA 33 technology by increasing both performance and data integrity. This new high-speed interface almost doubles the Ultra DMA 66 burst data transfer rate to 100 Mbytes/sec. The result is maximum disc performance using the current PCI local bus environment. Another benefit is you can connect four IDE devices in your system through either Ultra DMA 66 or Ultra DMA 100. You will have more flexibility to expand your computer system.

SD7-533 includes C-Media's newest 6-channel audio processor chip CMI 8738. The CMI-8738 supports legacy audio - SBPRO™, FM emulator and DLS (Downloadable Sound) -based wavetable music synthesizer, DirectMusic™, and HRTF 3D positional audio functions. The drivers support EAX®, as well as Karaoke Key and Echo functions. It can provide HRTF-based 3D positional audio (C3DX™), and uses HRTF 3D extension technology to enhance traditional HRTF 3D positional audio by substituting two-speaker system with a four- or six-speaker one (it supports additional 2 ch 16-bit DAC to provide rear side audio and another 2 ch for subwoofer/Center). It greatly improves HRTF 3D positional audio quality and successfully removes sweet spot limitations. This way, users can enjoy genuine 3D audio gaming effects without having to worry about environmental confinements. Also provided is a 6-channel kit (CA-20), which includes extra 4-channel signal output jack, two S/PDIF jack (In/Out) and two USB ports (USB 1.1).

This motherboard also supports five PCI slots and one AGP slot. In addition, this motherboard gives users enormous flexibility through ABIT's SoftMenu™ III with plenty clock frequency selections. The user is able to alter both the FSB speed and the multiplier to get the CPU processing speed of your choice. This motherboard has built-in hardware monitoring functions that monitors and protects your computer,

ensuring a safe computing environment.

## 1-2. Specifications

---

### 1. Processor

- Supports Intel® Pentium® 4 socket 478 processor with 400 MHz (100 MHz Quad Data Rate) CPU front side bus
- Supports future 400 MHz FSB processors for the Intel™ Pentium™ 4 processors

### 2. Chipset (SiS 645 and SiS 961):

- Supports Ultra DMA 33, Ultra DMA 66 and Ultra DMA 100 IDE protocol
- Supports Advanced Configuration and Power Management Interface (ACPI)
- Accelerated Graphics Port connector supports AGP 2X (3.3V) and 4X (1.5V) mode (Sideband) device
- Supports 200 MHz/266 MHz/333 MHz (100 MHz/133 MHz/166 MHz Double Data Rate) memory bus settings

### 3. Memory (System Memory)

- Three 184-pin DIMM slots support PC 1600/PC 2100/PC 2700 DDR SDRAM modules
- Supports up to **Two** unbuffered DDR DIMMs for **PC 2700** DDR modules (up to **2 GB**)
- Supports up to **Three** unbuffered DDR DIMMs for **PC 1600/PC 2100** DDR modules (up to **3 GB**)

### 4. System BIOS

- SOFT MENU™ III technology, can easily set the processor parameters
- Award Plug and Play BIOS supports APM and DMI
- Write-Protect Anti-Virus function by AWARD BIOS

### 5. Audio Function

- C-Media 8738 / PCI - 6 channels PCI-Based HRTF (**Head-Related Transfer Functions**) 3 dextension positional audio chip
- Supports 6 channels DAC (**D**igital to **A**nalog **C**onverter) for AC3 5.1 channels purpose
- Professional digital audio interface supporting 24-bit S/PDIF (Sony/Philips **D**igital **I**nter**F**ace) input and output

### 6. Multi I/O Functions

- One floppy port connector (up to 2.88MB)
- Two channels of Bus Master IDE ports supporting up to four Ultra DMA 33/66/100 devices
- One PS/2 keyboard and PS/2 mouse connectors
- One parallel port connector (Standard/EPP/ECP)
- Two serial ports connectors
- Two USB connectors
- Two USB header for four extra USB channels
- One audio connector (Line-in, Line-out, Mic-in, and Game port)

## 7. Miscellaneous

- ATX form factor
  - One AGP slot, five PCI slots
  - Built-in IrDA TX/RX header
  - Two built-in SM-Bus header
  - Hardware monitoring : Included fan speed, voltages, processor and system environment temperature
  - Board size: 305 \* 230mm
- ✱ **The Switching Power Supply must meet ATX 2.03 specification with ATX12V1 Power connector.**
- ✱ **Supports Wake On LAN, Modem, but your ATX power supply 5V standby power must be able to provide at least a 720mA current capacity. Otherwise, the functions may not work normally.**
- ✱ **This motherboard supports the standard bus speeds of 66MHz/100MHz/133MHz that are used by specific PCI, processor and chipset specifications. Exceeding these standard bus speeds is not guaranteed due to the specific component specifications.**
- ✱ **Specifications and information contained in this manual are subject to change without notice.**

### Note

All brand names and trademarks are the property of their respective owners.

## 1-3. Item Checklist

Check that your package is complete. If you discover any damaged or missing items, please contact your retailer or dealer.

- One ABIT SD7-533 Motherboard
- One 80-wire/40-pin ribbon cable for master and slave Ultra DMA 100, Ultra DMA 66 or Ultra DMA 33 IDE devices
- One ribbon cable for 3.5" floppy disk devices
- One compact disc for support drivers and utilities
- One CA-20 back panel plate with cables
- One user's manual for the motherboard

### 1-4. Layout Diagram for SD7-533

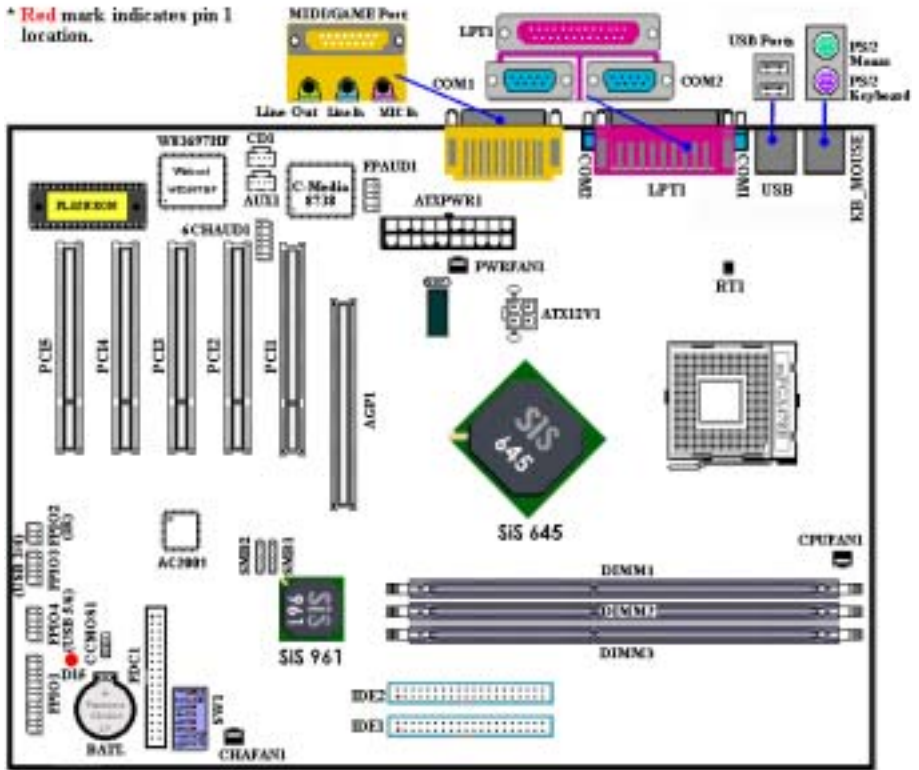

Figure 1-1. SD7-533 motherboard component location



Figure 1-2. CA-20 Back Panel Diagram

---

## Chapter 2. Installing the Motherboard

---

This SD7-533 motherboard not only provides all standard equipment for classic personal computers, but also provides great flexibility for meeting future upgrade demands. This chapter will introduce step-by-step all of the standard equipment and will also present, as completely as possible, future upgrade capabilities. This motherboard is able to support all Intel® Pentium® 4 processors now on the market. (For details, see specifications in Chapter 1.)

This chapter is organized according the following features:

2-1 Install The Motherboard

2-2 Install Intel® Pentium® 4 processor and Heatsink Supporting-Base

2-3 Install System Memory

2-4 Connectors, Headers and Switches



### **Before Proceeding with the Installation**



Before you install or unplug any connectors or add-on cards, please remember to turn the ATX power supply switch off (fully turn the +5V standby power off), or take the power cord off. Otherwise, you may cause the motherboard components or add-on cards to malfunction or be damaged.



---

### **User Friendly Instructions**

Please read our instructions carefully and follow them step-by-step. Our objective is to enable the novice computer user to perform the installation by himself. We have attempted to write this document in a very clear, concise and descriptive manner to help overcome any obstacles you may face during installation.

---

### **Diagram and Photos**

This chapter contains many color drawings, diagrams and photos, we strongly recommend you read this chapter use the PDF file that is stored on the CD-Title. Color improves the clarity and quality of the diagrams. For the downloadable edition, as files larger than 3 MB are difficult to download, we will cut the graphics and photo resolution to reduce the manual file size. In such this case, if your manual is downloaded from our WEB site and not from a CD-ROM, enlarging graphics or photos will distort the image.

## 2-1. Installing the Motherboard to the Chassis

Most computer chassis will have a base on which there will be many mounting holes that allows the motherboard to be securely attached and at the same time, prevents short circuits. There are two ways to attach the motherboard to the base of chassis:

- With studs
- Or with spacers

Please refer to figure 2-1, which shows the studs and spacers. There may be several types, but all look like the figures below:



Figure 2-1. The outline of stud and spacer

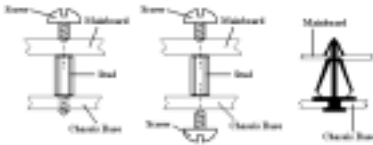

Figure 2-2. The way we fixed the motherboard

In principle, the best way to attach the motherboard is with studs. Only if you are unable to do this should you attach the board with spacers. Take a careful look at the motherboard and you will see many mounting holes on it. Line these holes up with the mounting holes on the base. If the holes line up and there are screw holes this means you can attach the motherboard with studs. If the holes line up and there are only slots, this means you can only attach the motherboard with spacers. Take the tip of the spacers and insert them into the slots. After doing this to all the slots, you can slide the motherboard into position aligned with the slots. After the motherboard has been positioned, check to make sure everything is OK before putting the casing back on.

Figure 2-2 shows you the way to affix the motherboard using studs or spacers.

### Note

If the motherboard has mounting holes, but they don't line up with the holes on the base and there are no slots to attach the spacers, don't worry, you can still attach the spacers to the mounting holes. Just cut the bottom portion of spacers (the spacer they may be a little hard to cut, so be careful with your hands). In this way you can still attach the motherboard to the base without worrying about short circuits. Sometimes you may need to use the plastic springs to isolate the screw from the motherboard PCB surface, because the circuit wire may be near by the hole. Be careful, don't let the screw contact any the printed circuit wire or parts on the PCB that are near the fixing hole, otherwise it may damage the board or cause board malfunctioning.

## 2-2. Install Pentium® 4 Processor and Heatsink Supporting-Base

This motherboard provides a ZIF (Zero Insertion Force) Socket 478 to install Intel® Pentium® 4 processor. The processor you bought should include a heatsink and cooling fan kit along with. If that's not the case, buy one specially designed for Pentium® 4 Socket 478. Please refer to figure 2-3 to install the processor.

1. Locate the Socket 478. Fasten the heatsink supporting-base onto the motherboard.

### Attention

If you are using chassis specially designed for Pentium® 4, please pay attention to the location of metal studs or spacers if they are already installed on the chassis. Be careful not let the metal studs or spacers contact the printed circuit wire or parts on the PCB.

2. Pull the processor socket lever sideways away from the socket and then upwards to 90 degrees. Insert the processor with the correct orientation. Push down the socket lever while holding down the processor.
3. Put the heatsink face down onto the processor until it completely covers the processor.
4. Put the heatsink supporting-cover onto the heatsink. Make sure all four locking clasps on each side of the supporting cover reach in the locking holes.
5. Push down the retaining clip on both sides of the supporting cover to lock together with the supporting base. Watch the direction you push down on the clip.
6. The heatsink supporting cover and base should now firmly lock together with the heatsink inside.

### Attention

Do not forget to set the correct bus frequency and multiple for your processor.

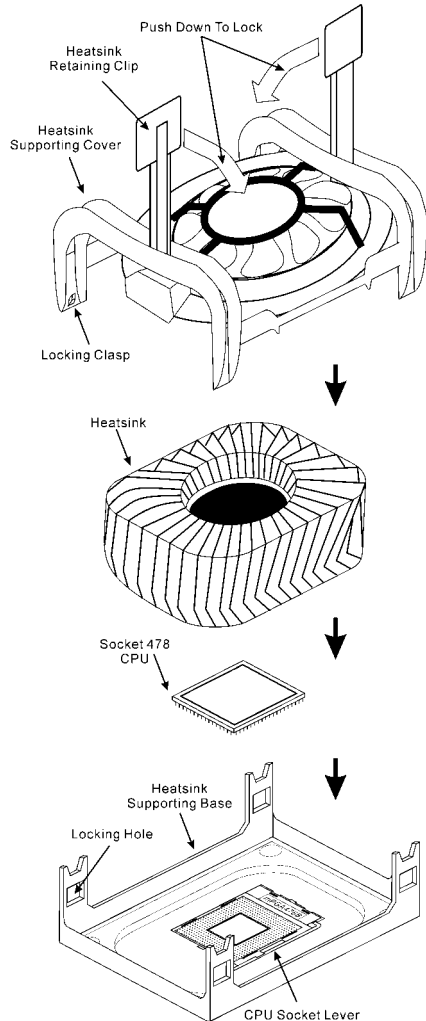

**Figure 2-3. Installing P4 Socket 478 processor and its heatsink onto supporting base.**

## 2-3. Installing System Memory

This motherboard provides three 184-pin DDR DIMM sites for memory expansion. The DDR DIMM sockets support 8 Mx64 (64 MB), 16 Mx64 (128 MB), 32 Mx64 (256 MB), 64 Mx64 (512 MB), and 128 Mx64 (1024 MB) or double density DDR DIMM modules. Minimum memory is 64 MB and the maximum memory is 2 GB (**Unbuffered PC 2700 DDR Module**) or 3 GB (**Unbuffered PC 1600/2100 DDR Module**) DDR SDRAM. There are three memory module sockets on the system board (for a total of six banks). In order to create a memory array, following rules must be followed.

- The memory array is 64 or 72 bits wide. (Depending on with or without parity)
- For those modules, we suggest that you be populate DIMM1 to DIMM3 in order.
- Supports single and double density DDR DIMMs.

Table 2-1. Valid Memory Configurations

Bank	Memory Module	Total Memory
Bank 0, 1 (DDR DIMM1)	64 MB, 128 MB, 256 MB, 512 MB, 1024 MB	64 MB ~ 1 GB
Bank 2, 3 (DDR DIMM2)	64 MB, 128 MB, 256 MB, 512 MB, 1024 MB	64 MB ~ 1 GB
Bank 4, 5 (DDR DIMM3)	64 MB, 128 MB, 256 MB, 512 MB, 1024 MB	64 MB ~ 1 GB
<b>Total System Memory for Unbuffered PC2700 DDR DIMM</b>		64 MB ~ 2 GB
<b>Total System Memory for Unbuffered PC1600/2100 DDR DIMM</b>		64 MB ~ 3 GB



Figure 2-4. PC1600/PC2100/PC2700 DDR Module and Component Mark

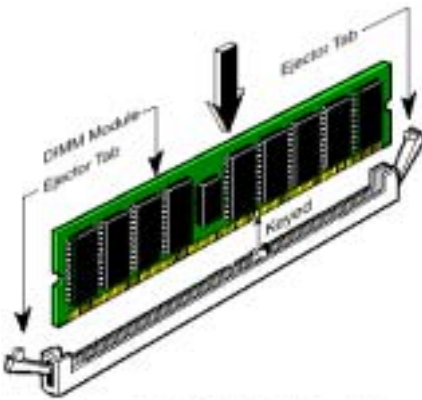

Figure 2-5. DDR DIMM module installation

Generally, installing DDR SDRAM modules to your motherboard is an easy thing to do. You can refer to Figure 2-4 to see what a 184-pin PC 1600, PC 2100 & PC 2700 DDR SDRAM module looks like.

Unlike installing SIMMs, DIMMs may be “snapped” directly into the socket. Note: Certain DDR DIMM sockets have minor physical differences. If your module doesn't seem to fit, please do not force it into the socket as you may damage your memory module or DDR DIMM socket.

The following procedure will show you how to install a DDR DIMM module into a DDR DIMM socket.

- Step 1.** Before you install the memory module, please place the computer power switch in the *off* position and disconnect the AC power cord from your computer.
- Step 2.** Remove the computer's chassis cover.
- Step 3.** Before touching any electronic components, make sure you first touch an unpainted, grounded metal object to discharge any static electricity stored on your clothing or body.

- Step 4.** Locate your computer's 184-pin memory expansion DDR DIMM socket.
- Step 5.** Insert the DDR DIMM module into the expansion socket as shown in the illustration. Note how the module is keyed to the socket. You can refer to Figure 2-5 for the details. ***This insures the DDR DIMM module will be plugged into the socket in one way only.*** Firmly press the DDR DIMM module into DDR DIMM socket, making certain the module is completely seated in the DDR DIMM socket.
- Step 6.** Once the DDR DIMM module has been installed, the installation is complete and the computer's cover can be replaced. Or you can continue to install other devices and add-on cards that are mentioned in the following section.

#### Note

When you install a DDR DIMM module fully into the DDR DIMM socket, the eject tab should be locked into the DDR DIMM module very firmly and fit into its indentation on the both sides.

It is difficult to differentiate between the PC 1600, PC 2100 and PC 2700 DDR SDRAM modules from the exterior. The only way you can identify them is to look at the sticker on the DDR SDRAM module. The sticker will tell you which kind of structure module the DDR SDRAM is.

## 2-4. Connectors, Headers and Switches

Inside the case of any computer, several cables and plugs have to be connected. These cables and plugs are usually connected one-by-one to connectors located on the motherboard. You need to carefully pay attention to any connection orientation the cables may have and, if any, notice the position of the first pin of the connector. In the explanations that follow, we will describe the significance of the first pin.

We will show you all of the connectors, headers and switches here, and tell you how to connect them. Please pay attention and read the entire section for necessary information before attempting to finish all hardware installation inside the computer chassis.

Figure 2-6 shows you all of the connectors and headers that we'll discuss in the next section, and you can use this diagram to visually locate each connector and header we describe.

All connectors, headers and switches mentioned here will depend on your system configuration. Some features you may (or may not) have and need to be connected or configured depending on the peripheral. If your system doesn't have such add-on cards or switches, you can safely ignore some special feature connectors.

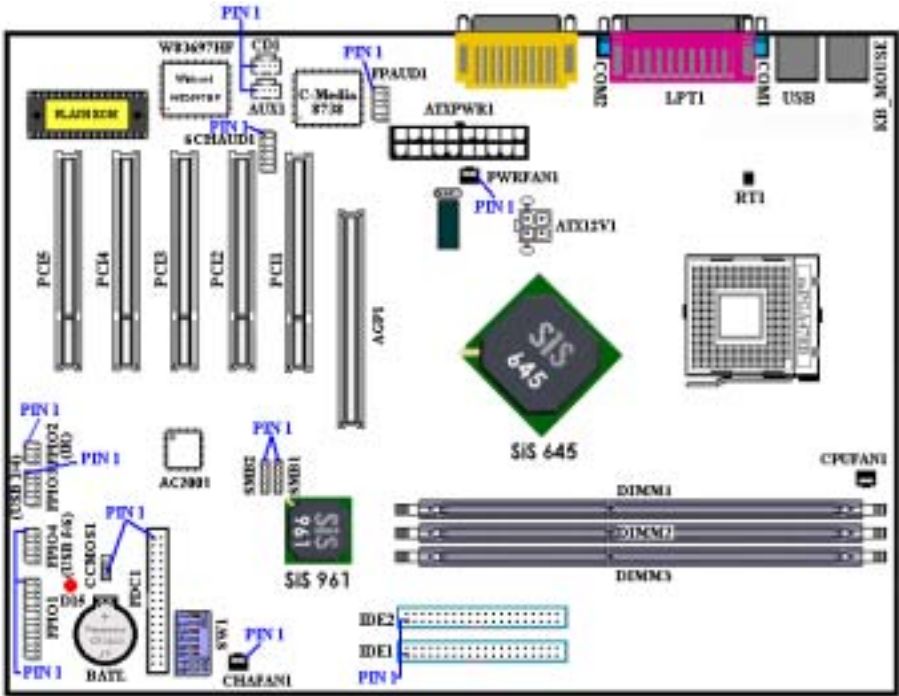
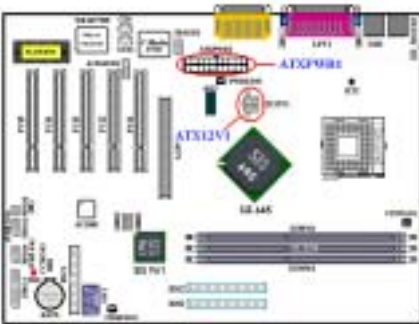

Figure 2-6. All Connectors and Headers for the SD7-533

First, Let's see the headers that SD7-533 uses, and what their functions are. We will show you all the connectors and headers.

**(1). ATXPWR1 and ATX12V1: ATX Power Input Connectors**



The Pentium® 4 requires a power supplier different from the regular one. It's a newly designed ATX12V1 power with 300W, 20A +5VDC capacity at least for heavily loaded system, and 720mA +5VSB at least for supporting **Wake-On-LAN** (WOL) or **Wake-On-Ring** (WOR) features.

Attach the connector from the power supply to the ATXPWR1 and ATX12V1 connectors here. Remember you have to push the connector from the ATX power supply firmly to the end with the ATXPWR1 and ATX12V1 connectors, insuring that you have a good connection.

*Note: Watch the pin position and the orientation.*

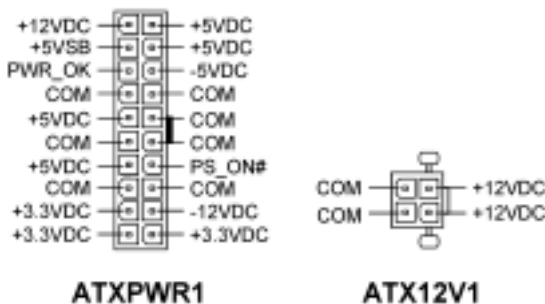

**Caution**

If the power supply connectors are not properly attached to the ATX power supply, the power supply or add-on cards may be damaged.

One end of AC power cord connects to ATX power supply, and the other end (AC plug) will plug into the wall outlet. Be aware that when facing the wall outlet, the round hole is in the middle. The right side slot is called live wire slot. It has a longer slot length than the left side slot. The left side slot is called the ground wire slot. You can use an electroscop to detect its polarity or you can use a voltage meter to measure the voltage of both slot sides. If you insert an electroscop into the live wire slot, the electroscop will light up. Using a voltage meter, you will find that the live wire slot will register a higher voltage.

If you reverse the polarity of AC plug, it may affect the life of computer equipment, or cause an electric shock when you touch the computer chassis. We suggest that you plug the computer AC plug to a three-hole wall outlet for better safety and to avoid electric shock.

**(2). CPUFAN1, CHAFAN1 and PWFAN1 headers**

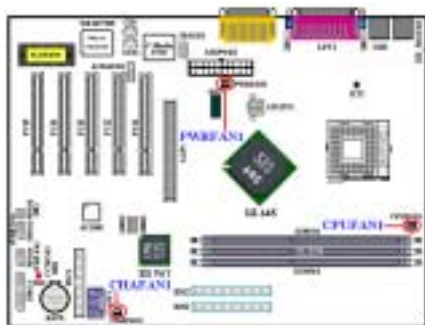

Attach the connector from the CPU fan to the header named CPUFAN1 and connector from the chassis fan to the header CHAFAN1. Attach the connector from the power fan to PWFAN1 header.

You must attach the CPU fan to the processor, or your processor will work abnormally or may be damaged by overheating. To prevent the computer chassis internal temperature from getting too high, also connect the chassis fan.



*Note: Watch the pin position and the orientation*

**(3). FPIO2: IR Header (Infrared)**

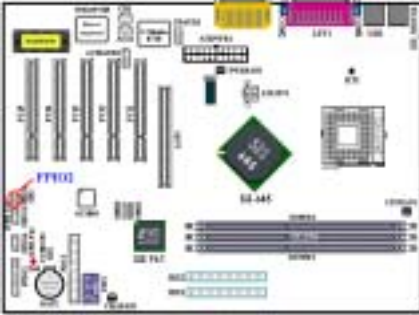

There is a specific orientation for pins 1 through 5, attach the connector from the IR KIT or IR device to the FPIO2 header. This motherboard supports standard IR transfer rates.



*Note: Watch the pin position and the orientation*

**(4). SMB1 and SMB2 System Management Bus (SM-Bus) Connectors**

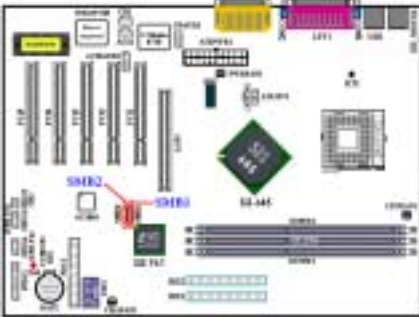

These two connectors are reserved for the system management bus (SM-Bus). The SM-Bus is a specific implementation of an I<sup>2</sup>C bus. I<sup>2</sup>C is a multi-master bus, this means that multiple chips can be connected to the same bus and each one can act as a master by initiating a data transfer. If more than one master

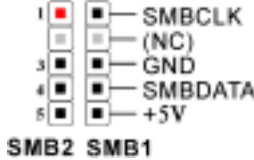

simultaneously tries to control the bus, an arbitration procedure decides which master gets priority. You can connect the devices that utilize the

SM-Bus.

*Note: Watch the pin position and the orientation*

**(5). RT1: System Temperature Thermistor**

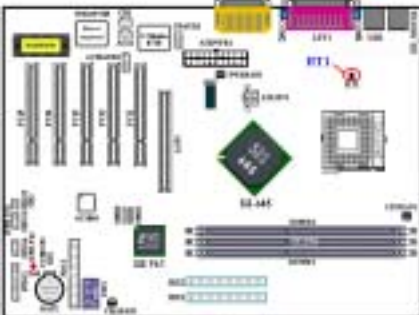

The RT1 is used to detect the system environment temperature. You can see the readings in the BIOS or the hardware monitoring software screen.

**(6). FPIO3 (USB 3/4) and FPIO4 (USB 5/6) Headers: Additional USB Plugs Header**

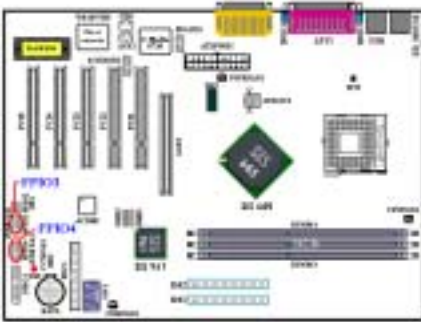

These headers are for connecting the additional USB port plugs. Each connector can provide two additional USB plugs for a total of four additional USB plugs. You can use the special USB port expansion cable to connect it (the cable come with the metal plate can fixed on the back panel of computer chassis). It can provide total of four additional USB plugs.



FPIO3 / FPIO4

**(7). CCMOS1: CMOS Discharge Jumper**

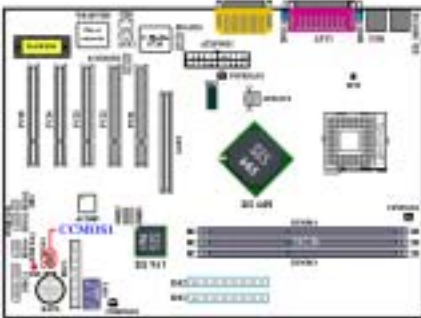

Jumper CCMOS1 discharge CMOS memory. When you install the motherboard, make sure this jumper is set for normal operation (pin 1 and 2 shorted). See Figure 2-7.



Figure 2-7. CCMOS1 jumper setting

**Note**

Before you clear the CMOS, you have to first turn the power off (including the +5V standby power). Otherwise, your system may work abnormally.

After updating your BIOS and before boot up, please clear the CMOS first. Then put the jumper to its default position. After that, you can reboot your system and ensure that your system is working fine.

### (8). **FPIO1 Headers: The Headers for Chassis's Front Panel Indicators and Switches**

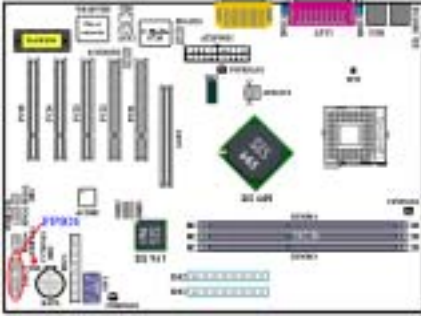

FPIO1 are for switches and indicators for the chassis's front panel, there are several functions that come from this header. You have to watch the pin position and the orientation, or you may cause LED do not light up. Figure 2-8 shows you the FPIO1 functions of the pins.

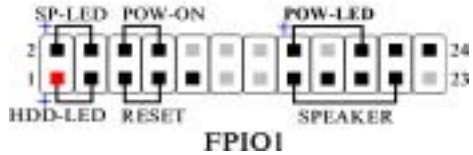

**Figure 2-8. The definition of FPIO1 pins**

#### **FPIO1 (Pin 1 & 3): HDD LED Header**

Attach the cable from the case's front panel HDD LED to this header. If you install it in the wrong direction, the LED light will not illuminate correctly.

*Note: Watch the HDD LED pin position and the orientation.*

#### **FPIO1 (Pin 5 & 7): Hardware Reset Switch Header**

Attach the cable from the case's front panel Reset switch to this header. Press and hold the reset button for at least one second to reset the system.

#### **FPIO1 (Pin 15-17-19-21): Speaker Header**

Attach the cable from the system speaker to this header.

#### **FPIO1 (Pin 2 & 4): Suspend LED Header**

Insert the two-threaded suspend LED cable into this header. If you install it in the wrong direction, the LED light will not illuminate correctly.

*Note: Watch the Suspend LED pin position and the orientation.*

#### **FPIO1 (Pin 6 & 8): Power On Switch Header**

Attach the cable from the case's front panel power on switch to this header.

#### **FPIO1 (Pin 16-18-20): Power On LED Headers**

There is a specific orientation for pins 1 through 3. Insert the three-threaded power on LED cable to this header. Check to make sure the correct pins go to the correct connectors on the motherboard. If you install them in the wrong direction, the power LED light will not illuminate correctly.

*Note: Watch the power LED pin position and orientation.*

For the PN1 and PN2 pin's count-name list, please refer to table 2-2.

Table 2-2. FPIO1 pin count name list

PIN Name		Significance of signal	PIN Name		Significance of signal
FPIO1	PIN 1	HDD LED (+)	FPIO1	PIN 2	SP-LED (+)
	PIN 3	HDD LED (-)		PIN 4	SP-LED (-)
	PIN 5	Reset SW (-)		PIN 6	PWR-ON (+)
	PIN 7	Reset SW (+)		PIN 8	PWR-ON (-)
	PIN 9	No Connection		PIN 10	No Pin
	PIN 11	No Pin		PIN 12	No Pin
	PIN 13	No Pin		PIN 14	No Pin
	PIN 15	Speaker (+5V)		PIN 16	PWR LED (+)
	PIN 17	Speaker (GND)		PIN 18	No Pin
	PIN 19	Speaker (GND)		PIN 20	PWR LED (-)
PIN 21	Speaker (Driver)	PIN 22	No Connection		
PIN 23	No Pin	PIN 24	No Connection		

### (9). FDC1 Connector

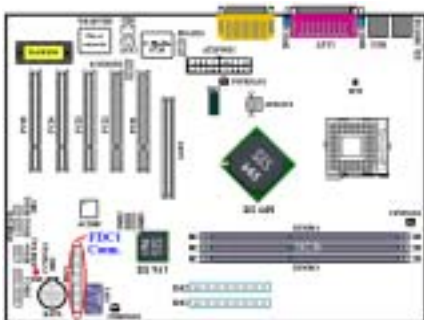

This 34-pin connector is called the “*floppy disk drive connector*”. You can connect a 720K, 3.5”, 1.44M, 3.5” or 2.88M, 3.5” floppy disk drive.

A floppy disk drive ribbon cable has 34 wires and two connectors to provide the connection of two floppy disk drives. After connecting the single end to the FDC1, connect the two connectors on the other end to the floppy disk drives. In general, people only install one floppy disk drive on their computer system.

#### Note

A red mark on a wire typically designates the location of pin 1. You need to align the wire pin 1 to the FDC1 connector pin 1, and then insert the wire connector into the FDC1 connector.

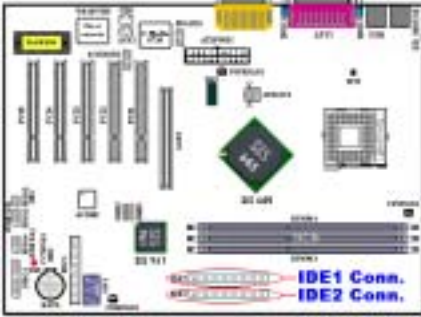
**(10). IDE1 and IDE2 Connectors**

This motherboard provides two IDE ports (IDE1 & IDE2) to connect up to four IDE devices in Ultra DMA 100 mode by Ultra DMA 66 ribbon cables. Each cable has 40-pin 80-conductor and three connectors, providing two hard drive connections with the motherboard. Connect the single end (blue connector) at the longer length of ribbon cable to the IDE port on motherboard, and the other two ends (gray and black connector) at the shorter length of the ribbon cable to the connectors on hard drives.

If you want to connect two hard drives together through one IDE channel, you must configure the second drive to Slave mode after the first Master drive. Please refer to the HDD documentation for jumper settings. The first drive connected to IDE1 is usually referred to as “Primary Master”, and the second drive as “Primary Slave”. The first drive connected to IDE2 is referred to as “Secondary Master” and the second drive as “Secondary Slave”.

Keep away from connecting one legacy slow speed device, like CD-ROM, together with another hard disk drive on the same IDE channel; this will decrease your integral system performance.

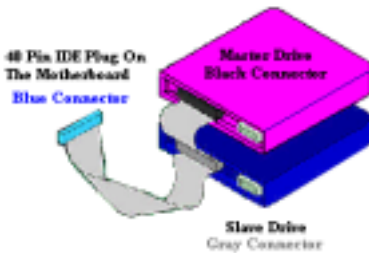
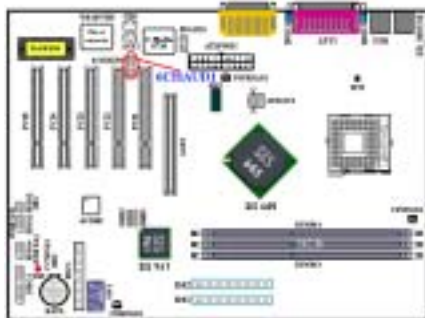

**Figure 2-9. Ultra DMA 66 Ribbon Cable Outline**

<b>Note</b>
-------------

- |                                                                                                                                                                                                                                                                                                                                                                                                                                                                                               |
|-----------------------------------------------------------------------------------------------------------------------------------------------------------------------------------------------------------------------------------------------------------------------------------------------------------------------------------------------------------------------------------------------------------------------------------------------------------------------------------------------|
| <ul style="list-style-type: none"> <li>● The Master or Slave status of the hard disk drive is set on the hard disk itself. Please refer to the hard disk drive user’s manual.</li> <li>● To connect Ultra DMA 100 devices on IDE1 and IDE2, an Ultra DMA 66 cable is required.</li> <li>● A red mark on a wire typically designates the location of pin 1. You need to align the wire pin 1 to the IDE connector pin 1 before inserting the wire connector into the IDE connector.</li> </ul> |
|-----------------------------------------------------------------------------------------------------------------------------------------------------------------------------------------------------------------------------------------------------------------------------------------------------------------------------------------------------------------------------------------------------------------------------------------------------------------------------------------------|

**(11). 6CHAUD1 Header: 6 Channels Audio Header**



**CA-20 Back Plat**

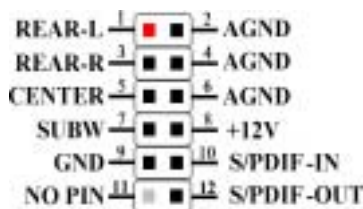

**6CHAUD1**

You'll see this header on SD7-533 motherboard. This header is designed to connect the CA-20. CA-20 can provide the analog audio output signals for center channel, subwoofer, rear right and rear left channel. It also provides one digital S/PDIF input and one digital S/PDIF output connector.

Another two USB connectors on CA-20 are provided for use for FPIO3 or FPIO4 headers. Please refer the description of FPIO3 and FPIO4 on item (6).

**(12). FPAUD1 Header: Front Panel Audio Header**

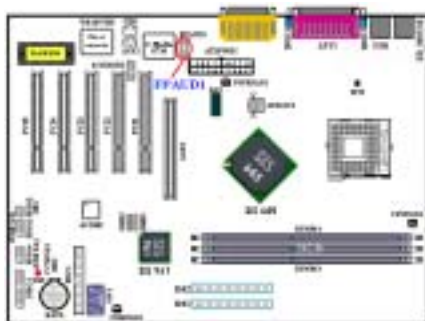

This header is reserved to transfer audio in/out signals and plugs from back panel connectors to front panel.



**FPAUD1**

**(13). CD1 and AUX1 Headers**

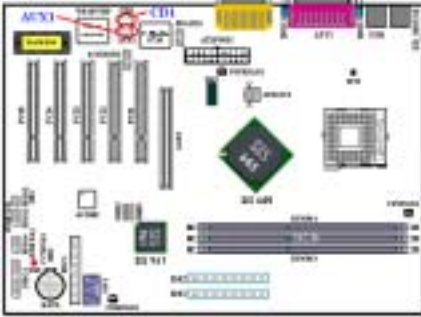

These connectors connect to the audio output of internal CD-ROM drive or add-on card.

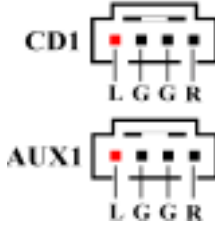

**(14). SW1 and D15: Processor Default Setting Switch and 5V Standby LED**

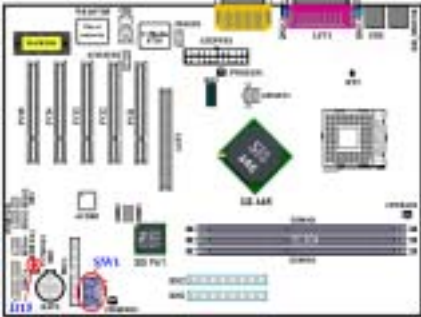

SW1 is a processor default setting switch, used to set and test in our factory. Please do not change the small DIP switches setting on SW1, as wrong settings may prevent your computer from booting.

The default setting of SW1 is: DIP SW 1, 3, 5 and 6 are set to "ON" position.

D15 will light up after the power switch is pressed, this LED will show you the 5V standby power situation.

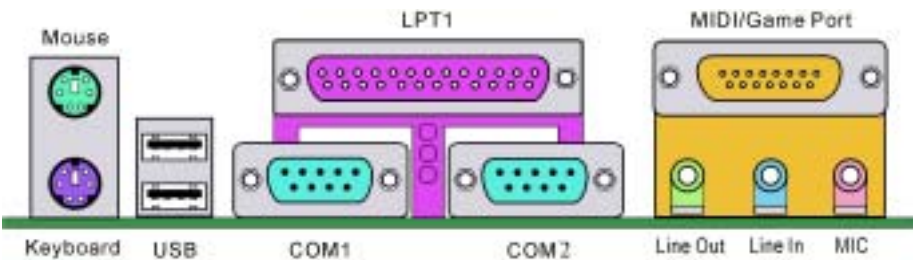

**Figure 2-10. SD7-533 back panel connectors**

Figure 2-10 shows the SD7-533 back panel connectors. These connectors are used for connecting outside devices to the motherboard. We will describe which devices will attach to these connectors below.

---

**(15). PS/2 Keyboard Connector**

Attach a PS/2 keyboard connector to this 6-pin Din-connector. If you use an AT keyboard, you can go to a computer store to purchase an AT to ATX converter adapter, then you can connect your AT keyboard to this connector. We suggest you use a PS/2 keyboard for best compatibility.

---

**(16). PS/2 Mouse Connector**

Attach a PS/2 mouse to this 6-pin Din-connector.

---

**(17). USB Port Connectors**

This motherboard provides two USB ports. Attach the USB connector from the individual device to these connectors.

You can attach USB devices such as a scanner, digital speakers, monitor, mouse, keyboard, hub, digital camera, joystick etc. to one of each USB connector. You must make sure your operating system supports this feature and you may need to install an additional driver for individual devices. In Please refer to your device user's manual for detailed information.



---

**(18). Serial Port COM1 & COM2 Port Connectors**

This motherboard provides two COM ports, you can connect an external modem, mouse or other devices that support this communication protocol to these connectors.

You can decide which external devices you want to connect to COM1 and COM2. Each COM port can only have one device connected at a time.

---

**(19). Parallel Port Connector**

This parallel port is also called an "LPT" port, because it usually connects to the printer. You can connect other devices that support this communication protocol, like an EPP/ECP scanner, etc.



**Note**

This chapter contains many color drawing diagram and photos, we strongly recommend you to read this chapter use the PDF file we gave you that store in the CD-Title. It will provide you the better look and clearly color identify.

## Chapter 3. Introducing the BIOS

The BIOS is a program located on a Flash Memory chip on the motherboard. This program will not be lost when you turn the computer off. This program is also referred to as the boot program. It is the only channel the hardware circuit has to communicate with the operating system. Its main function is to manage the setup of the motherboard and interface card parameters, including simple parameters such as time, date, hard disk drive, as well as more complex parameters such as hardware synchronization, device operating mode, **SOFT MENU™ III** features and setup of processor speed. The computer will operate normally, or will operate at its best, only if all of these parameters are correctly configured through the BIOS.



**Don't change the parameters inside the BIOS unless you fully understand the meanings and consequences**

The parameters inside the BIOS are used to setup the hardware synchronization or the device-operating mode. If the parameters are not correct, they will produce errors, the computer will crash, and sometimes you will even not be able to boot the computer after it has crashed. We recommend that you do not change the parameters inside the BIOS unless you are very familiar with them. If you are not able to boot your computer anymore, please refer to the section “**CCMOS1 Discharge Jump<sup>®</sup>**” in Chapter 2 to see how to discharge the CMOS date.

When you start the computer, the BIOS program controls it. The BIOS first operates an auto-diagnostic test called POST (Power On Self Test) for all of the necessary hardware. It then configures the parameters of the hardware synchronization, and detects all of the hardware. Only when these tasks are completed does it give up control of the computer to the program to the next level, which is the operating system (OS). Since the BIOS is the only channel for hardware and software to communicate, it is the key factor for system stability, and in insuring that your system performs at its best. After the BIOS has achieved the auto-diagnostic and auto-detection operations, it will display the following message:

### PRESS DEL TO ENTER SETUP

The message will be displayed for three to five seconds, if you press the **Del** key, you will access the BIOS Setup menu. At that moment, the BIOS will display the following message:



Figure 3-1. CMOS Setup Utility Screen Shot

In the BIOS Setup main menu of Figure 3-1, you can see several options. We will explain these options step by step in the following pages of this chapter, but let us first see a short description of the function keys you may use here:

- Press **Esc** to quit the BIOS Setup.
- Press **↑ ↓ ← →** (up, down, left, right) to choose, in the main menu, the option you want to confirm or to modify.
- Press **F10** when you have completed the setup of BIOS parameters to save these parameters and to exit the BIOS Setup menu.
- Press **Page Up/Page Down** or **+/-** keys when you want to modify the BIOS parameters for the active option.

#### Note

Parts of the screenshot may not same as you see on your screen, because the BIOS version may change periodically. However, most of the functions covered in this manual will work. We suggest that you go to our WEB site often to see if there are new manual releases. Then you can check the newly updated BIOS items.

#### Computer Knowledge: CMOS Data

Maybe you have heard somebody saying that his or her CMOS DATA was lost. What is the CMOS? Is it important? The CMOS is the memory used to store the BIOS parameters that you have configured. This memory is passive. You can read its data, and you can also store data in it. But this memory has to be powered by a battery, in order to avoid any loss of its data when the computer is turned off. Since you may have to change the CMOS battery when it is out of power and if doing so, you will loose all CMOS data, therefore, we recommend that you write down all the parameters of your hardware, or to put a label with these parameters on your hard disk.

### 3-1. SOFT MENU™ III Setup

The processor can be setup through a programmable switch (**SOFT MENU™ III**) that replaces the traditional manual hardware configuration. This feature allows the user to more easily complete the installation procedures. You can install the processor without configuring any jumpers or switches. The processor must be setup according to its specifications. In the first option, you can press <Enter> at any time to display all the items that can be chosen for that option.

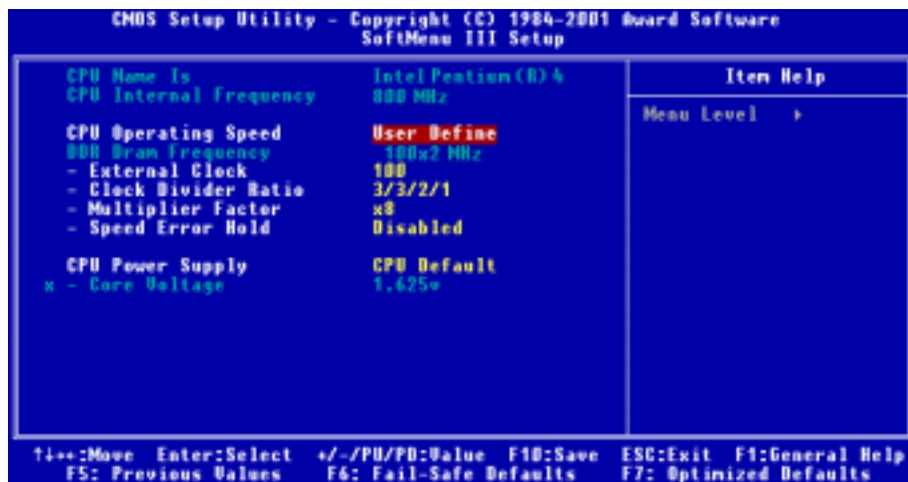

Figure 3-2. CPU SOFT MENU™ III Screen Shot

#### CPU Name Is:

Intel▶ Pentium (R) 4

#### CPU Internal Frequency:

This item will automatically show the processor internal frequency. You can't make any changes to this item.

#### CPU Operating Speed:

This option sets the processor speed. In this field, the processor speed is indicated like this: Processor Speed = External Clock x Multiplier Factor. Select the processor speed according to the type and speed of your processor. For Intel® Pentium® 4 processors, you can choose from the following settings from 800 (100) ~ 2300 (100), and User Define.

#### Note

The display of this item might be different depending on the processor you installed. The above is just an example.

User defined external clock and multiplier factor:

► **User Defined:**

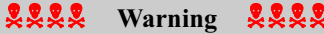

**Warning**



The wrong settings of the multiplier and external clock in certain circumstances may cause processor damage. Setting the working frequency higher than the specifications of PCI or processor may cause abnormal memory module functioning, system hangs, hard disk drive data loss, abnormal functioning of the VGA card, or abnormal functioning with other add-on cards. Using non-specification settings for your processor is not the intention of this explanation, for which should be used for engineering testing only, and not for normal operation.

If you use non-specification settings for normal operation, your system may not be stable, and may affect system reliability. Also, we do not guarantee the stability and compatibility for settings that are not within specification, and any damage of any elements on the motherboard or peripherals is not our responsibility.

**DDR Dram Frequency:**

You can't changes the setting here, as it depends on the following items to determine the value.

► **External Clock:**

You can increase the processor clock speed here. This means that you can independently increase the processor FSB clock speed. The DEC (decimal) numbers from 100 to 165 are available, with the default setting at 100. You can change this setting to increase processor FSB clock speed. The processor FSB speed above the standard bus speed is supported, but not guaranteed due to processor specifications.

► **Clock Divider Ratio:**

This item lets you set the DDR SDRAM, AGP and PCI clock. It correlates with the processor FSB clock you set. Many of options are available, you can choose the divider ratio you want. The default setting is 3/3/2/1. In this case, the DDR SDRAM clock will be the processor FSB clock divided by 3 and times 3. The AGP clock will be the processor FSB clock divided by 3 and times 2. The PCI clock will be the processor FSB clock divided by 3 and times 1. In non-user define mode, we'll open several items to let you make choice, it useful for you to adjust the synchronous speed between the processor and DDR SDRAM. For example: 3/3/2/1, 3/4/2/1/, 48/80/30/15.

► **Multiplier Factor:**

The multiplier factors for this motherboard are: x8, x10 ... x24. (These factors vary with the different type and specification of the processor installed)

**Note**

Some processors may have the multiplier factor locked, so there is no way to choose a higher multiplier factor.

► **Speed Error Hold:**

Two options are available: Disabled → Enabled. The default setting is *Disabled*. This option selects to hold or not when the processor speed setting is wrong. Normally, we do not recommend you to use the "User Define" option to setup processor speed and multiplier factors. This option is for setup of future processors whose specifications are still unknown. It is very easy to make mistakes when defining the external clock and multiplier factor by yourself, unless you are very familiar with all processor parameters.

Normally, we do not recommend that you use the “**User Define**” option to setup processor speed and PCI clock. This option is for setup of future processors whose specifications are still unknown. The specifications of all present processors are included in the default settings. Unless you are very familiar with all processor parameters, it is very easy to make mistakes when you define the external clock and the multiplier factor by yourself.

#### **Solution in case of booting problem due to invalid clock setup:**

Normally, if the processor clock setup is wrong, you will not be able to boot. In this case, turn the system off then on again. The processor will automatically use its standard parameters to boot. You can then enter the BIOS Setup again and set up the processor clock. If you can't enter the BIOS setup, you must try turning the system on a few times (3~4 times) or press “**INSERT**” key when turning on and the system will automatically use its standard parameters to boot. You can then enter BIOS SETUP again and set up the new parameters.

#### **When you change your processor:**

This motherboard has been designed in such a way that you can turn the system on after having inserted a processor in the socket without having to configure any jumpers or DIP switches. But if you change your processor, normally you just have to turn off the power supply, change the processor and then, set up the processor parameters through **SOFT MENU™ III**. However, if the new processor is slower than the old one (and is same brand and type), we offer you two methods to successfully complete the processor change.

**Method 1:** Setup up the processor for the lowest speed for its brand. Turn the power supply off and change the processor. Then turn the system on again, and set up the processor parameters through **SOFT MENU™ III**.

**Method 2:** Since you have to open the computer case when you change the processor, it could be a good idea to use the CCMOS jumper to erase the parameters of the original processor and enter BIOS Setup to set up processor parameters again.

#### **Attention**

After setting up the parameters and leaving the BIOS SETUP, and having verified that the system can be booted, do not press the Reset button or turn off the power supply. Otherwise the BIOS will not read correctly, the parameters will fail and you must enter **SOFT MENU™ III** again to set up the parameters all over again.

#### **CPU Power Supply:**

This option allows you to switch between “**CPU Default**” and “**User Define**” voltages.

- **CPU Default:** The system will detect the processor type and select the proper voltage automatically. When it is enabled, the option “**Vcore Voltage**” will show the current voltage setting that is defined by the processor and this will not be changeable. We recommend using this processor default setting and not changing it unless the current processor type and voltage setting can't be detected or is not correct.
- **User Define:** This option lets the user select the processor core voltage manually. You can change values of the “**Core Voltage**” option lists by using the <Page Up> and <Page Down> keys.

#### ☛ **Core Voltage:**

After setting the item “**CPU Power Supply**” as “**User Define**”, you can change this core voltage from 1.1v through 2.20v by using <Page Up> and <Page Down> keys. (These values vary with the different type and specification of the processor installed)

## 3-2. Standard CMOS Features Setup Menu

This contains the basic configuration parameters of the BIOS. These parameters include date, hour, VGA card, floppy disk and HDD settings.



Figure 3-3A. Standard CMOS Features Screen Shot

### Date (mm:dd:yy):

You can set the date in this item: month (mm), date (dd) and year (yy).

### Time (hh:mm:ss):

You can set the time in this item: hour (hh), minute (mm) and second (ss).

### **IDE Primary Master / Slave and IDE Secondary Master / Slave:**

These items have a sub-menu to let you choose further options. You can refer to figure 3-3B to check what options are available.

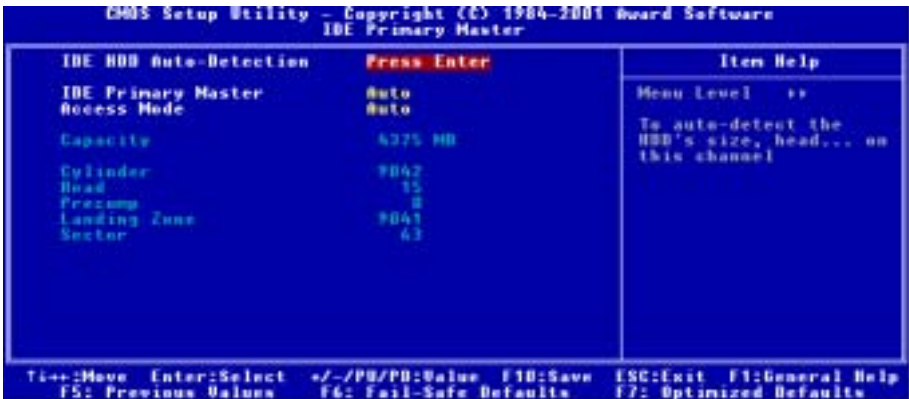

Figure 3-3B. IDE Primary Master Screen Shot

---

**IDE HDD Auto-Detection:**

Press the *Enter* key for the BIOS to auto detect all detailed parameters of the hard disk drivers (HDD). If auto detection is successful, the correct values will be shown in the remaining items of this menu.

**Note**

- ❶ A new IDE HDD must be first formatted, otherwise it can't do the read/write. The basic step in using a HDD is to run FDISK, and then FORMAT the drive. Most current HDDs have already been subjected to low-level format at the factory, so you can probably skip this operation. Remember though, the primary IDE HDD must have its partition set to active within the FDISK procedure.
- ❷ If you are using an old HDD that is already formatted, auto detection can't detect the correct parameters. You may need to do a low-level format or set the parameters manually, and then check if the HDD is working.

---

**IDE Primary Master:**

Three settings are available: *Auto*, *Manual* and *None*. If you choose *Auto*, the BIOS will automatically check what kind hard disk you are using. If you want to set the HDD parameters yourself, make sure you fully understand the meaning of the parameters, and be sure to refer to the manual provided by the HDD manufacture to get the settings right.

---

**Access Mode:**

Since old operating systems were only able to support HDDs with capacities no bigger than 528MB, any hard disk with more than 528MB was unusable. AWARD BIOS features a solution to this problem: you can, according to your operating system, choose four operating modes: CHS → LBA → LARGE → Auto.

The HDD auto detection option in the sub-menu will automatically detect the parameters of your hard disk and the mode supported.

➤ **CHS (Normal mode):**

Standard normal mode supports hard disks of up to 528MB or less. This mode directly uses positions indicated by Cylinders (CYLS), Heads, and Sectors to access data.

➤ **LBA (Logical Block Addressing) mode:**

The earlier LBA mode can support HDD capacities of up to 8.4GB, and this mode uses a different method to calculate the position of disk data to be accessed. It translates Cylinders (CYLS), Heads and Sectors into a logical address where data is located. The Cylinders, Heads, and Sectors displayed in this menu do not reflect the actual structure of the hard disk, they are just reference values used to calculate actual positions. Currently, all high capacity hard disks support this mode, that's why we recommend you use this mode. Currently, the BIOS can support the INT 13h extension function, enabling the LBA mode to support hard disk drive capacities exceeding 8.4GB.

➤ **Large Mode:**

When the number of cylinders (CYLs) of the hard disk exceeds 1024 and DOS is not able to support it, or if your operating system does not support LBA mode, you should select this mode.

➤ **Auto:**

Just let the BIOS detect your HDD access mode and make the decisions.

**Capacity:**

This item auto displays your HDD size. Note that this size is usually slightly greater than the size given by a disk checking program of a formatted disk.

**Note**

All the items below are available when you set the item *Primary IDE Master* to *Manual*.

**Cylinder:**

When disks are placed directly above one another along the shaft, the circular vertical "slice" consisting of all the tracks located in a particular position is called a cylinder. You can set the number of cylinders for a HDD. The minimum number you can enter is 0, the maximum number you can enter is 65536.

**Head:**

This is the tiny electromagnetic coil and metal pole used to create and read back the magnetic patterns on the disk (also called the read/write head). You can configure the number of read/write heads. The minimum number you can enter is 0, the maximum number you can enter is 255.

**Precomp:**

The minimum number you can enter is 0, the maximum number you can enter is 65536.

**Warning**

Setting a value of 65536 means no hard disk exists.

**Landing Zone:**

This is a non-data area on the disk's inner cylinder where the heads can rest when the power is turned off. The minimum number you can enter is 0, the maximum number you can enter is 65536.

**Sector:**

The minimum segment of track length that can be assigned to stored data. Sectors usually are grouped into blocks or logical blocks that function as the smallest units of data permit. You can configure this item to sectors per track. The minimum number you can enter is 0, the maximum number you can enter is 255.

---

**Driver A & Driver B:**

If you have installed the floppy disk drive here, then you can select the type of floppy drive it can support. Six options are available: None → 360K, 5.25 in. → 1.2M, 5.25in. → 720K, 3.5 in. → 1.44M, 3.5 in. → 2.88M, 3.5 in.

---

**Floppy 3 Mode Support:**

Four options are available: Disabled → Driver A → Driver B → Both. The default setting is *Disabled*. 3 Mode floppy disk drives (FDD) are 3 1/2" drives used in Japanese computer systems. If you need to access data stored in this kind of floppy, you must select this mode, and of course you must have a 3 Mode floppy drive.

**Video:**

You can select the VGA modes for your video adapter, four options are available: EGA/VGA → CGA 40 → CGA 80 → MONO. The default setting is EGA/VGA.

**Halt On:**

You can select which type of error will cause the system to halt. Five options are available: All Errors → No Errors → All, But Keyboard → All, But Diskette → All, But Disk/Key.

You can see your system memory list in the lower right box, it shows the *Base Memory*, *Extended Memory* and *total Memory size* configurations in your system. It is detected by the system during boot-up procedure.

### 3-3. Advanced BIOS Features Setup Menu

In each item, you can press <Enter> at any time to display all the options for this item.

**Attention**

Advanced BIOS Features Setup Menu has already been set for maximum operation. If you do not really understand each of the options in this menu, we recommend you use the default values.

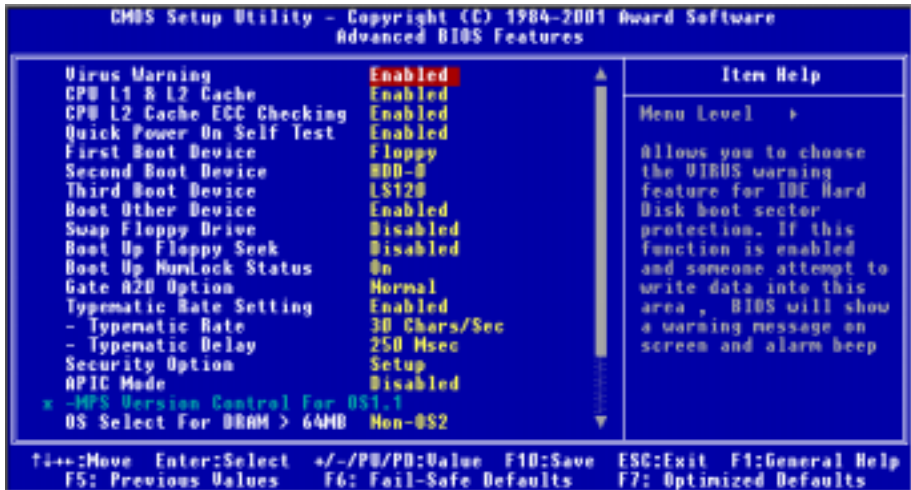

Figure 3-4A. Advanced BIOS Features Upper Screen Shot

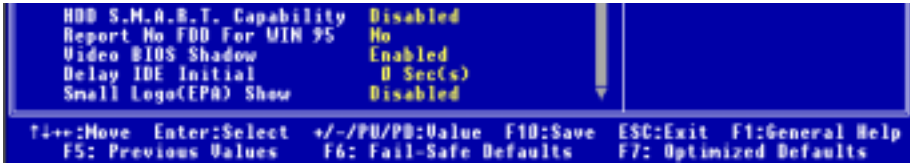

Figure 3-4B. Advanced BIOS Features Lower Screen Shot

---

### **Virus Warning:**

This item can be set to Enabled or Disabled, the default setting being *Disabled*.

When this feature is enabled, if there is any attempt from a software or an application to access the boot sector or the partition table, the BIOS will warn you that a boot virus is attempting to access the hard disk.

---

### **CPU L1 & L2 Cache:**

Two options are available: Disabled or Enabled. The default setting is *Enabled*. This item is used to enable or to disable the processor's level 1 and level 2 cache. When the cache is set to *Disabled* it is much slower, so the default setting for this item is *Enabled* since it will speed up memory access. Some older software will make the computer malfunction or crash if the system speed is too high. In this case, you should disable this feature.

---

### **CPU L2 Cache ECC Checking:**

Two options are available: Enabled or Disabled. The default setting is *Enabled*. This item is used to enable or to disable the processor level 2 cache ECC checking function.

---

### **Quick Power On Self Test:**

Two options are available: Disabled or Enabled. The default setting is *Enabled*. After the computer has been powered on, the BIOS of the motherboard will run a series of tests in order to check the system and its peripherals. If the Quick Power on Self-Test feature is enable, the BIOS will simplify the test procedures in order to speed up the boot process.

---

### **First Boot Device:**

When the computer boots up, the BIOS attempts to load the operating system from the devices in the sequence selected in these items: floppy disk drive A, LS120, ZIP100 devices, hard drive C, SCSI hard disk drive or CD-ROM. There are ten options for the boot sequence that you can choose (The default setting is *Floppy*):

Floppy → LS120 → HDD-0 → SCSI → CDROM → HDD-1 → HDD-2 → HDD-3 → ZIP100 → LAN  
 → Disabled → Back to Floppy.

---

### **Second Boot Device:**

Description is the same as the *First Boot Device*, the default setting is *HDD-0*.

---

### **Third Boot Device:**

Description is same as the *First Boot Device*, the default setting is *LS120*.

---

**Boot Other Device:**

Two options are available: Disabled or Enabled. The default setting is *Enabled*. This setting allows the BIOS to try to boot devices other than the three which are listed in the above First, Second and Third Boot Devices. If you set to Disabled, the BIOS will boot from only the three kinds of boot devices that are set above.

---

**Swap Floppy Drive:**

This item can be set as Disabled or Enabled. The default setting is *Disabled*. When this feature is enabled, you don't need to open the computer case to swap the position of floppy disk drive connectors. Drive A can be set as drive B and drive B can be set as drive A.

---

**Boot Up Floppy Seek:**

Two options are available: Disabled or Enabled. The default setting is *Enabled*. When the computer boots up, the BIOS detects if the system has a FDD or not. When this item is set to "Enabled", if the BIOS detects no floppy drive, it will display a floppy disk drive error message. If this item is disabled, the BIOS will skip this test.

---

**Boot Up NumLock Status:**

- Off: At boot up, the Numeric Keypad is in cursor control mode.
- On: At boot up, the Numeric Keypad is in numeric mode. (Default Settings)

---

**Gate A20 Option:**

Two options are available: Normal or Fast. The default setting is *Normal*. Gate A20 refers to the way the system addresses memory above 1 MB (extended memory). When set to Fast, the system chipset controls Gate A20. When set to Normal, a pin in the keyboard controller controls Gate A20. Setting Gate A20 to Fast improves system speed, particularly with OS/2 and Windows.

---

**Typematic Rate Setting:**

This item allows you to adjust the keystroke repeat rate. When set to *Enabled*, you can set the two keyboard typematic controls that follow (*Typematic Rate* and *Typematic Delay*). If this item is set to *Disabled*, the BIOS will use the default setting. The default setting is *Enabled*.

**• *Typematic Rate:***

When you press a key continuously, the keyboard will repeat the keystroke according to the rate you have set (Unit: characters/second). Eight options are available: 6 → 8 → 10 → 12 → 15 → 20 → 24 → 30 → Back to 6. The default setting is 30.

**• *Typematic Delay:***

When you press a key continuously, if you exceed the delay you have set here, the keyboard will automatically repeat the keystroke according to a certain rate (Unit: milliseconds). Four options are available: 250 → 500 → 750 → 1000 → Back to 250. The default setting is 250.

---

**Security Option:**

This option can be set to System or Setup. The default setting is *Setup*. After you have created a password through PASSWORD SETTING, this option will deny access to your system (System) or modification of computer setup (BIOS Setup) by unauthorized users.

- **SETUP:** When you choose Setup, a password is required only when accessing the BIOS Setup. If the correct password is not given, you can't enter the BIOS setup menu.
- **SYSTEM:** When you choose System, a password is required each time the computer boots up. If the correct password is not given, the system will not start.

To disable security, select *Set Supervisor Password* at main menu and then you will be asked to enter password. Do not type anything and just press the *Enter* key and it will disable security. Once security is disabled, the system will boot and you can enter the *BIOS setup menu* freely.

---

**Notice**

Don't forget your password. If you forget the password, you will have to open the computer case and clear all information in the CMOS before you can start up the system. But by doing this, you will have to reset all previously set options.

---

**APIC Mode:**

Two options are available: Disabled or Enabled. The default setting is *Disabled*. If you set to *Enabled*, the next item will be available to choose. When you set it to *Disabled*, the system will use the default five PCI IRQs for all devices, and will not increase the number of PCI IRQs.

---

**MPS Version Control For OS1.4:**

This option specifies which version of MPS the motherboard will use.

Two options available: 1.1 ➔ 1.4. The BIOS supports versions 1.1 and 1.4 of the Intel<sup>®</sup> multiprocessor specification. Select the version supported by the operating system running on this computer. If you use an older OS for dual processor executing, please set this option to 1.1.

---

**Note**

The SiS 645 A1 version chipset will not show the items "**ACPI Mode**" and "**MPS Version Control For OS1.4**", if the SiS 645 chipset version is A2, then these two items will shown in the BIOS.

---

**OS Select For DRAM > 64MB:**

Two options are available: Non-OS2 or OS2. The default setting is *Non-OS2*. When the system memory is bigger than 64MB, the communication method between the BIOS and the operating system will differ from one operating system to another. If you use OS/2, select *OS2*, if you are using another operating system, select *Non-OS2*. The default setting is *Non-OS2*.

---

**HDD S.M.A.R.T. Capability:**

Two options are available: Disabled or Enabled. The default setting is *Disabled*. SMART (Self-Monitoring Analysis and Reporting Technology) is a techniques which warns users of the HDD's defects and informs the users to transfer HDD's data to other places. Therefore, this technique results in improving the confidence in data preservation and the HDD itself. Therefore, if you make sure your HDD has supports this feature, then set this item to Enabled. This allows the operating system to take the necessary precautions and warn the user. For detailed information of your HDD specs, please read the HDD's user's manual or contact the dealer.

---

**Report No FDD For WIN 95:**

When using Windows® 95 without a floppy drive set this item to *Yes*. Otherwise, set it to *No*. The default setting is *No*.

---

**Video BIOS Shadow:**

This option is used to define whether the BIOS on the video card uses the shadow feature or not. You should set this option to *Enabled*, otherwise the display performance of the system will greatly decrease.

---

**Computer Knowledge: SHADOW**

What is the SHADOW? The BIOS of standard video or interface cards is stored in ROM, and it is often very slow. With the Shadow feature, the processor reads the BIOS on the VGA card and copies it into RAM. When the processor runs this BIOS, the operation is speeded up.

---

**Delay IDE Initial:**

This item is used to support some old models or special types of hard disks or CD-ROMs. They may need a longer amount of time to initialize and prepare for activation. Since the BIOS may not detect those kinds of devices during system booting. You can adjust the value to fit such devices. Larger values will give more delay time to the device. The minimum number you can enter is 0, the maximum number you can enter is 15. The default setting is 0.

---

**Small Logo(EPA) Show:**

Two options are available: *Disabled* or *Enabled*. The default setting is *Disabled*. If you set to *Enabled*, when computer reboot then you can see the EPA logo on the up right corner of the screen.

### 3-4. Advanced Chipset Features Setup Menu

The Chipset Features Setup Menu is used to modify the contents of the buffers in the chipset on the motherboard. Since the parameters of the buffers are closely related to hardware, if the setup is not correct or is false, the motherboard will become unstable or you will not be able to boot up. If you don't know the hardware very well, use default values (i.e. use the LOAD SETUP DEFAULTS option).

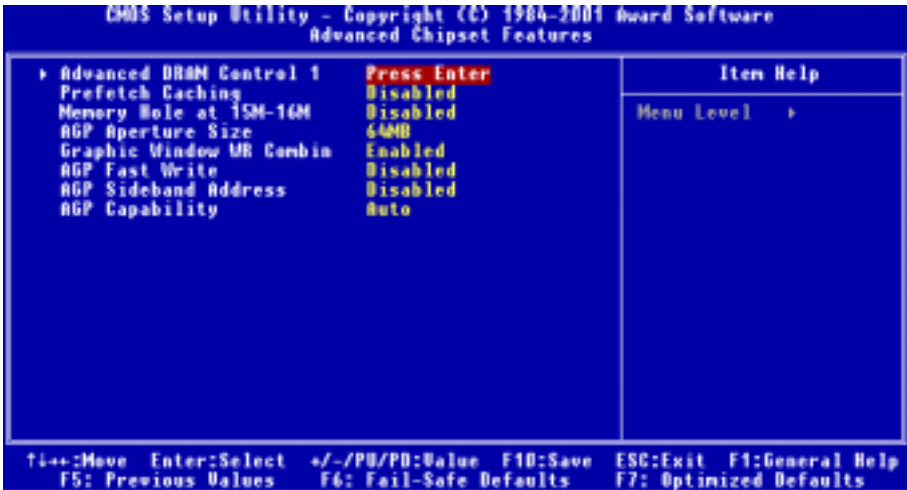

Figure 3-5A. Advanced Chipset Features Screen Shot

You can use the arrow keys to move between the items. Use **PgUP**, **PgDn**, **+** or **-** key to change the values. When you have finished setting up the chipset, press **ESC** to go back to the main menu.

#### Note

The parameters in this screen are for system designers, service personnel, and technically competent users only. Do not reset these values unless you understand the consequences of your changes.

### Advanced DRAM Control 1:

This item can let you set several items concerning the DRAM parameters. If you do not understand what each item does, please keep the default settings. Wrong settings may cause system instability, data loss or even prevent boot up!

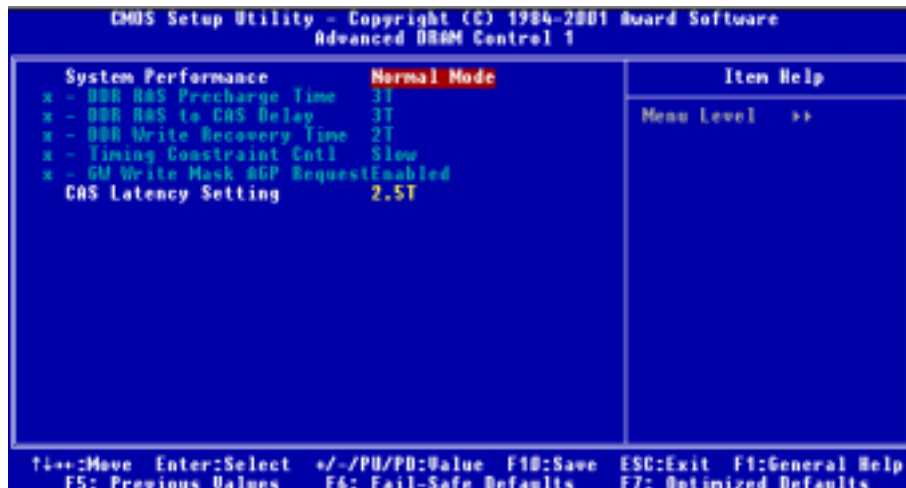

Figure 3-5B. Advanced DRAM Control 1 Screen Shot

#### System Performance:

Six options are available: Manual Mode → Safe Mode → Normal Mode → Fast Mode → Turbo Mode → Ultra Mode. The default setting is *Normal Mode*. If you choose the *Manual Mode*, the following items will be available.

##### • DDR RAS Precharge Time (tRP):

Three options are available: 3T → 2T → 4T. The default setting is 3T. This item is to set SDR/DDR SDRAM RAS precharge time. It can define the SDRAM precharge to ACT command period.

tRP timing value (Precharge time – time from precharge command to when back can be activated).

##### • DDR RAS to CAS Delay (tRCD):

Three options are available: 3T → 2T → 4T. The default setting is 3T. This item is to set SDR/DDR SDRAM RAS to CAS delay. It can define the SDRAM ACT to Read/Write command period.

tRCD timing value = RAS to CAS latency + rd/wr command delay

##### • DDR Write Recovery Time (tWR):

Two options are available: 2T → 1T. The default setting is 2T. This item is to set SDR/DDR SDRAM write recovery time. This item (bit) controls the number of clock cycles that must occur from the last valid write operation to the earliest time a new Precharge command can be asserted to the same bank. When you set it to 1T, tWR duration is 1 clock cycle, etc.

**► Timing Constraint Cntl:**

Two options are available: Slow → Normal. The default setting is *Slow*. Timing Constraint Control on DDR SDRAM Back-to-Back write Commands which are issued to different ranks.

**► GW Write Mask AGP Request (Graphic Window Write Mask AGP Request):**

Two options are available: Enabled → Disabled. The default setting is *Enabled*. When you set to *Enabled*, a graphic window write operation will forbid AGP device to access memory until this write operation is finished. When set to *Disabled*, AGP request can access memory as usual.

---

**CAS Latency Setting:**

Three options are available: 2T → 2.5T → 3T. The default setting is *2.5T*. You can select SDRAM CAS (Column Address Strobe) latency time according your SDRAM specification.

---

**Prefetch Caching:**

Two options are available: Disabled or Enabled. The default setting is *Disabled*. This item controls the prefetch caching for PCI slave control.

---

**Memory Hole at 15M-16M:**

Two options are available: Disabled or Enabled. The default setting is *Disabled*. This option is used to free up the memory block 15M-16M. Some special peripherals need to use a memory block located between 15M and 16M. We recommend that you disable this option.

---

**AGP Aperture Size:**

Seven options are available: 4MB → 8MB → 16MB → 32MB → 64MB → 128MB → 256MB → Back to 4MB. The default setting is *64MB*. This option specifies the amount of system memory that can be used by the AGP device. The aperture is a portion of the PCI memory address range dedicated for graphics memory address space. Host cycles that hit the aperture range are forwarded to the AGP without any translation. See <http://www.agpforum.org> for AGP information.

---

**Graphic Window WR Combin:**

Two options are available: Disabled or Enabled. The default setting is *Enabled*. This register defines the starting address of the graphic windows for GUI (Graphic Unit Interface), you can enable or disable this register. It also affect by the Graphic Window Control Register, this register controls accessibility and effectiveness of this register.

The Graphic Window Control Register specifies the size of the graphic window and indicates that whether the Graphic Windows Base Address (GWBA) Register and Re-mapping GART Base Address Register contain valid information or not. It also controls the accessibility of GWBA register.

**AGP Fast Write:**

Two options are available: Enabled or Disabled. The default setting is *Disabled*. If your AGP adapter can support this function, then you can choose *Enabled*. Otherwise, choose *Disabled*. Enabling this item can improve your system performance, but it may also decrease system compatibility.

**AGP Sideband Address:**

Two options are available: Disabled or Enabled. The default setting is *Disabled*. If your AGP adapter can support this function, then you can choose *Enabled*. Otherwise, choose *Disabled*. Enabling this item can improve your system performance, but it may also decrease system compatibility.

**AGP Capability:**

Three options are available: Auto/4X → 2X → 1X. The default setting is *Auto/4X*. If you use the older AGP adapter that does not support AGP 4X mode, you need to set this item to 2X or 1X. You can check your AGP adapter user's manual to know what kind of AGP mode it can support.

## 3-5. Integrated Peripherals

In this menu, you can change the onboard I/O device, I/O port address and other hardware settings.

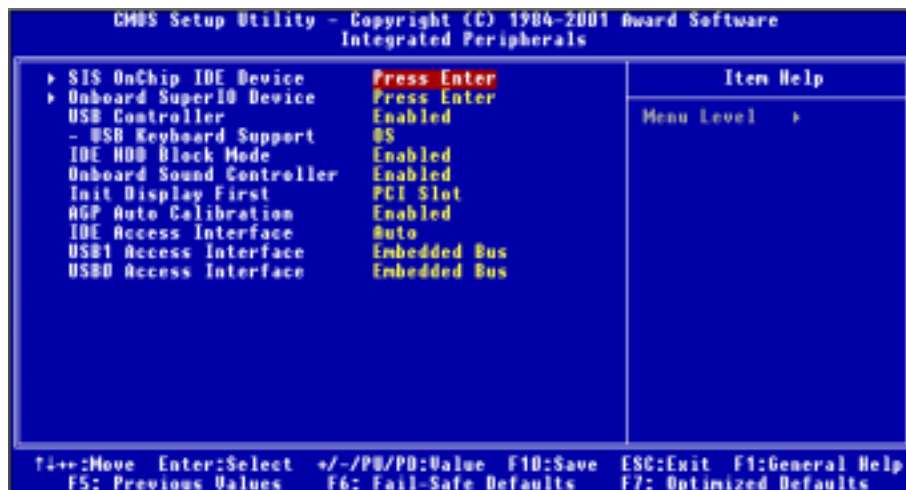

Figure 3-6A. Integrated Peripherals Screen Shot

### SIS OnChip IDE Device:

This item can let you sets several items concerning the SIS OnChip IDE device parameters.

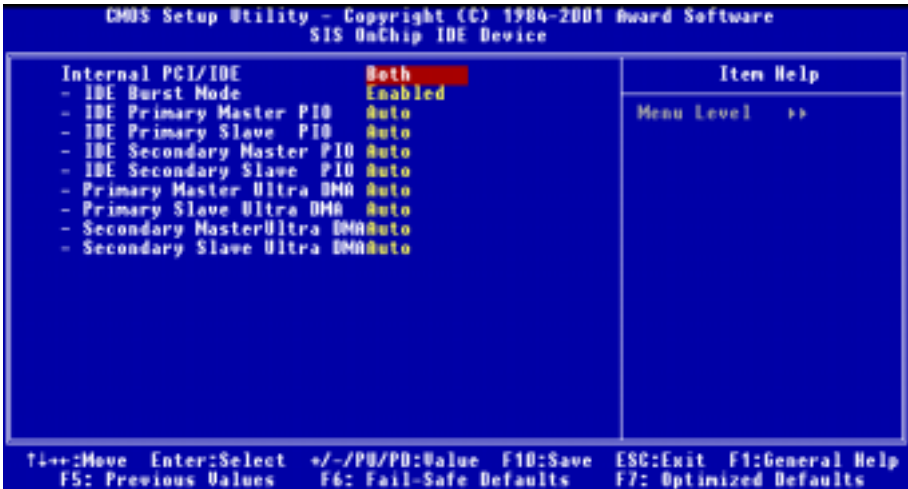

Figure 3-6B. SIS OnChip IDE Device Screen Shot

#### Internal PCI/IDE:

Four options are available: Disabled → Primary → Secondary → Both. The default setting is *Both*. This item allows you disable all internal PCI/IDE devices, or enable one of them. Of course you can enable both PCI/IDE devices as well. The enabled items will appear white in color and disabled items will show in a blue green color.

#### ☛ IDE Burst Mode:

Two options are available: Disabled or Enabled. The default setting is *Enabled*. Selecting Enabled reduces latency between each drive read/write cycle, but may cause instability in IDE subsystems that cannot support such fast performance. If you are getting disk drive errors, try setting this value to Disabled. This field is not available to enter when the “*Internal PCI/IDE*” field is *Disabled*.

#### ☛ IDE Primary Master PIO:

Six options are available: Auto → Mode 0 → Mode 1 → Mode 2 → Mode 3 → Mode 4. The default setting is *Auto*. The BIOS can auto-detect the transfer mode of the IDE devices in order to set its data transfer rate (Default). You can select the PIO mode from Mode 0 to Mode 4 of the IDE devices in order to set its data transfer rate. This field is not available to enter when the “*Internal PCI/IDE*” field is *Disabled* or *Secondary*.

#### ☛ IDE Primary Slave PIO:

Six options are available: Auto → Mode 0 → Mode 1 → Mode 2 → Mode 3 → Mode 4. The default setting is *Auto*. The BIOS can auto-detect the transfer mode of the IDE devices in order to set its data transfer rate (Default). You can select the PIO mode from Mode 0 to Mode 4 of the IDE devices in order to set its data transfer rate. This field is not available to enter when the “*Internal PCI/IDE*” field is *Disabled* or *Secondary*.

**• IDE Secondary Master PIO:**

Six options are available: Auto → Mode 0 → Mode 1 → Mode 2 → Mode 3 → Mode 4. The default setting is *Auto*. The BIOS can auto-detect the transfer mode of the IDE devices in order to set its data transfer rate (Default). You can select the PIO mode from Mode 0 to Mode 4 of the IDE devices in order to set its data transfer rate. This field is not available to enter when the “*Internal PCI/IDE*” field is *Disabled* or *Primary*.

**• IDE Secondary Slave PIO:**

Six options are available: Auto → Mode 0 → Mode 1 → Mode 2 → Mode 3 → Mode 4. The default setting is *Auto*. The BIOS can auto-detect the transfer mode of the IDE devices in order to set its data transfer rate (Default). You can select the PIO mode from Mode 0 to Mode 4 of the IDE devices in order to set its data transfer rate. This field does not appear when the “*Internal PCI/IDE*” field is *Disabled* or *Primary*.

**• Primary Master Ultra DMA:**

Two options are available: *Disabled* or *Auto*. The default setting is *Auto*. Ultra DMA is a DMA data transfer protocol that utilizes ATA commands and the ATA bus to allow DMA commands to transfer data at a maximum burst rate of 100 MB/sec.

If you encounter the problem of using Ultra DMA devices, you can try to set this item to *Disabled*. When you select *Auto*, the system automatically determines the optimal data transfer rate for each IDE device. This field is not available to enter when the “*Internal PCI/IDE*” field is *Disabled* or *Secondary*.

**• Primary Slave Ultra DMA:**

Two options are available: *Disabled* or *Auto*. The default setting is *Auto*. Ultra DMA is a DMA data transfer protocol that utilizes ATA commands and the ATA bus to allow DMA commands to transfer data at a maximum burst rate of 100 MB/sec.

If you encounter the problem of using Ultra DMA devices, you can try to set this item to *Disabled*. When you select *Auto*, the system automatically determines the optimal data transfer rate for each IDE device. This field is not available to enter when the “*Internal PCI/IDE*” field is *Disabled* or *Secondary*.

**• Secondary Master Ultra DMA:**

Two options are available: *Disabled* or *Auto*. The default setting is *Auto*. Ultra DMA is a DMA data transfer protocol that utilizes ATA commands and the ATA bus to allow DMA commands to transfer data at a maximum burst rate of 100 MB/sec.

If you encounter the problem of using Ultra DMA devices, you can try to set this item to *Disabled*. When you select *Auto*, the system automatically determines the optimal data transfer rate for each IDE device. This field is not available to enter when the “*Internal PCI/IDE*” field is *Disabled* or *Primary*.

**• Secondary Slave Ultra DMA:**

Two options are available: *Disabled* or *Auto*. The default setting is *Auto*. Ultra DMA is a DMA data transfer protocol that utilizes ATA commands and the ATA bus to allow DMA commands to transfer data at a maximum burst rate of 100 MB/sec.

If you encounter the problem of using Ultra DMA devices, you can try to set this item to *Disabled*. When you select *Auto*, the system automatically determines the optimal data transfer rate for each IDE device. This field is not available to enter when the “*Internal PCI/IDE*” field is *Disabled* or

Primary.

### Onboard Super IO Device:

This item can let you sets several items concerning the onboard super I/O device parameters.

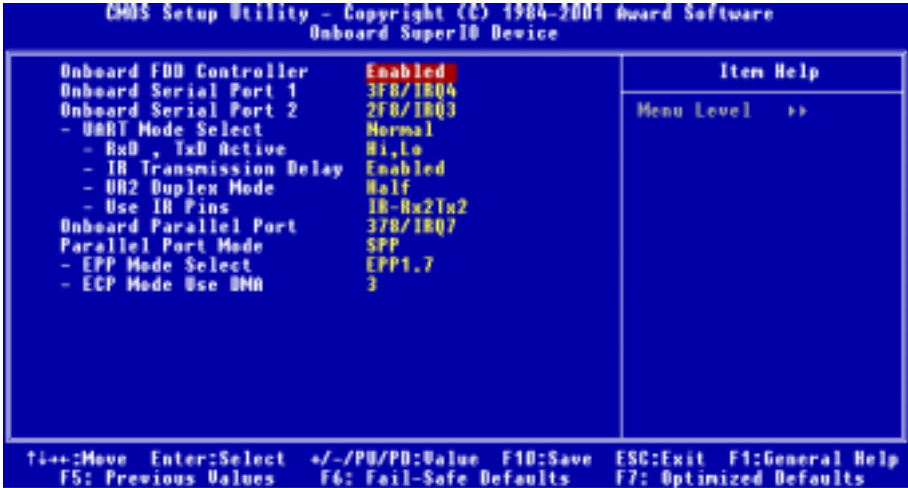

Figure 3-6C. Onboard Super IO Device Screen Shot

#### Onboard FDD Controller:

Two options are available: Disabled or Enabled. The default setting is *Enabled*. This is used to enable or disable the Onboard FDD Controller. If you add a higher performance controller, you will need to *Disable* this feature.

#### Onboard Serial Port 1:

This item allows you to determine which I/O address the onboard serial port 1 controller will access. Six options are available: Disabled → 3F8/IRQ4 → 2F8/IRQ3 → 3E8/IRQ4 → 2E8/IRQ3 → Auto → Back to Disabled. The default setting is *3F8/IRQ4*.

#### Onboard Serial Port 2:

This item allows you to determine which I/O address the onboard serial port 2 controller will access. Six options are available: Disabled → 3F8/IRQ4 → 2F8/IRQ3 → 3E8/IRQ4 → 2E8/IRQ3 → Auto → Back to Disabled. The default setting is *2F8/IRQ3*.

#### • *UART Mode Select:*

Three options are available: IrDA → ASKIR (Amplitude Shift Keyed IR) → Normal. The default setting is *Normal*.

#### • *RxD , TxD Active:*

Four options are available: Hi, Hi → Hi, Lo → Lo, Hi → Lo, Lo. The default setting is *Hi, Lo*. Set IR transmission/reception polarity as High or Low.

**• IR Transmission Delay:**

Two options are available: Disabled or Enabled. The default setting is *Enabled*. Set IR transmission delays 4 character-time (40 bit-time) when SIR is changed from RX mode to TX mode.

**• UR2 Duplex Mode:**

Two options are available: Full or Half. The default setting is *Half*.

Select the value required by the IR device connected to the IR port. Full-duplex mode permits simultaneous two-direction transmission. Half-duplex mode permits transmission in only one direction at a time.

**• Use IR Pins:**

Two options are available: RxD2, Tx2 or IR-Rx2Tx2. The default setting is *IR-Rx2Tx2*. If you choose *RxD2*, *TxD2*, your motherboard must support a COM port IR KIT connection. Otherwise, you can only choose the *IR-Rx2Tx2* to use the IR header on your motherboard to connect your IR KIT. Please use the default setting.

**Note**

The setting for item “**RxD, Tx Active**”, also called “**TX, RX inverting**”, allows you to determine the activity of RxD and Tx. We set it to “**Hi, Lo**”. If your motherboard BIOS uses “**No**” and “**Yes**” to represent this item, you should set it to the same setting as the SD7-533. This means that you should set it to “**No, Yes**” in order to match the transfer and receiving speed. If you fail to do so, you will not get an IR connection between the SD7-533 and the other computer.

**Onboard Parallel Port:**

Four options are available: Disabled → 378/IRQ7 → 278/IRQ5 → 3BC/IRQ7. The default setting is 378/IRQ7. Select a logical LPT port name and matching address for the physical parallel (printer) port.

**• Parallel Port Mode:**

Four options are available: SPP → EPP → ECP → ECP+EPP. Default is *SPP* mode. Select an operating mode for the onboard parallel (printer) port. SPP (Standard Parallel Port), EPP (Extended Parallel Port), ECP (Extended Capabilities Port) or ECP plus EPP.

Select SPP unless you are certain your hardware and software supports both EPP or ECP mode. According to your selection, the following items will appear.

**• EPP Mode Select:**

Two options are available: EPP1.9 → EPP1.7. The default setting is *EPP1.7*. When the mode selected for the parallel port mode is EPP, the two EPP mode options are available.

**• ECP Mode Use DMA:**

Two options are available: 1 → 3. The default setting is 3. When the mode selected for the onboard parallel port is ECP or ECP+EPP, the DMA channel selected can be 1 (Channel 1) or 3 (Channel 3).

**USB Controller:**

Two options are available: Disabled → Enabled. The default setting is *Enabled*. This should be enabled if your system has a USB device installed on the system board and you wish to use it. If you add a higher performance controller, you will need to disable this feature. If you choose disable this item, the “**USB Keyboard Support**” item will disappear in *Integrated Peripherals* menu.

---

**USB Keyboard Support:**

Two options are available: OS → BIOS. The default setting is *OS*. If your operating system supports a USB keyboard, please set it to *OS*. Only in some situations, such as in a pure DOS environment that does not support a USB keyboard, should you set it in BIOS.

---

**IDE HDD Block Mode:**

Two options are available: Disabled or Enabled. The default setting is *Enabled*. Block mode is also called block transfer, multiple commands, or multiple sector read/write. If your IDE hard drive supports block mode (most new drives do), select Enabled for automatic detection of the optimal number of block read/writes per sector the drive can support.

---

**Onboard Sound Controller:**

Two options are available: Disabled or Enabled. The default setting is *Enabled*. This item will allow you to enable or disable the onboard sound controller.

---

**Init Display First:**

Two options are available: PCI Slot or AGP. The default setting is *PCI Slot*. When you install more than one display card, you can choose either a PCI display card (PCI Slot) or an AGP display card (AGP) to display the boot-up screen. If you have only installed one display card, the BIOS will detect which slot (AGP or PCI) you installed it, and everything will be taken care of by the BIOS.

---

**AGP Auto Calibration:**

Two options are available: Enabled or Disabled. The default setting is *Enabled*. This item allows the BIOS to automatically calibrate the AGP's performance. We suggest you set this item to *Enabled*.

---

**IDE Access Interface:**

Three options are available: Auto → Embedded Bus → PCI Bus. The default setting is *Auto*. This item can let you choose which access interface you want IDE devices to use.

---

**USB1 Access Interface:**

Two options are available: PCI Bus → Embedded Bus. The default setting is *Embedded Bus*. This item can let you choose which access interface you want USB1 devices to use.

---

**USB0 Access Interface:**

Two options are available: PCI Bus → Embedded Bus. The default setting is *Embedded Bus*. This item can let you choose which access interface you want USB0 devices to use.

---

### 3-6. Power Management Setup Menu

The difference between Green PCs and traditional computers is that Green PCs have a power management feature. With this feature, when the computer is powered on but inactive, the power consumption is reduced in order to save energy. When the computer operates normally, it is in Normal mode. In this mode, the Power Management Program will control the access to video, parallel ports, serial ports and drives, and the operating status of the keyboard, mouse and other device. These are referred to as Power Management Events. In cases where none of these events occur, the system enters the power saving mode. When one of the controlled events occurs, the system immediately returns to normal mode and operates at its maximum speed. Power saving modes can be divided into three modes according to their power consumption: Doze Mode, Standby Mode, and Suspend Mode. The four modes proceed in the following sequence:

Normal Mode ==> Doze Mode ==> Standby Mode ==> Suspend Mode



The system consumption is reduced according the following sequence:

Normal > Doze > Standby > Suspend

1. In the Main Menu, select “Power Management Setup” and press “Enter”. The following screen is displayed:

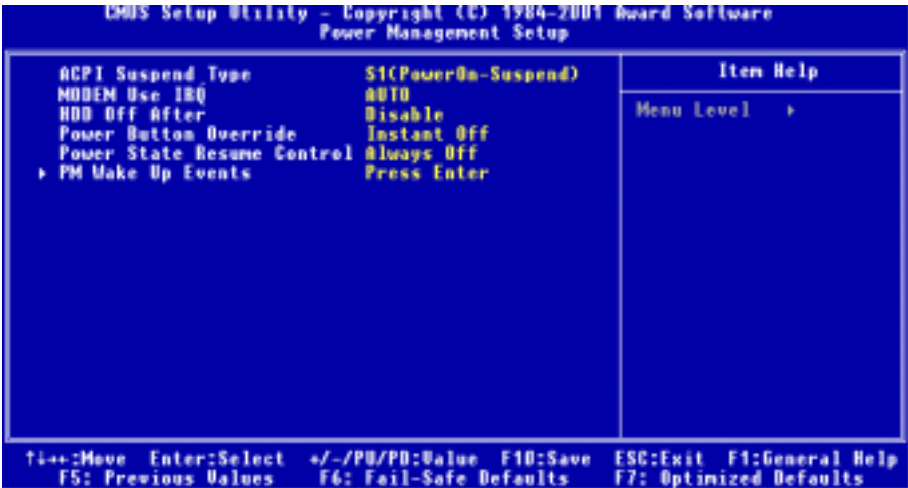

Figure 3-7A. Power Management Setup Screen Shot

2. You can use the arrow keys to move between the items. Use **PgUP**, **PgDn**, + or - key to change the values. When you have finished setting up the chipset, press **ESC** to go back to the main menu.
3. After you have configured the Power Management feature, press **Esc** to go back to the Main Menu.

We are now going to briefly explain the options in this menu:

### ACPI Function (Advanced Configuration and Power Interface):

ACPI gives the operating system direct control over the power management and Plug and Play functions of a computer. The ACPI functions are always “**Enabled**”. If you want ACPI functions to work normally, you should notice two things. One is your operating system must support ACPI, as of now only Microsoft® Windows® 98 and Windows® 2000 supports these functions. The second thing is that all devices and add-on cards in your system must fully support ACPI, both hardware and software (drivers). If you want to know if your devices or add-on cards support ACPI or not, please contact the device or add-on card manufacture for more information. If you want to know more about ACPI specifications, please go to the address below for more detailed information:

<http://www.teleport.com/~acpi/acpihtml/home.htm>

**Note:** If you enable the ACPI function in the BIOS setup, the SMI function will not work.

ACPI requires an ACPI-aware operating system. ACPI features include:

- Plug and Play (including bus and device enumeration) and APM functionality normally contained in the BIOS.
- Power management control of individual devices, add-in cards (some add-in cards may require an ACPI-aware driver), video displays, and hard disk drives.
- A Soft-off feature that enables the operating system to power off the computer.
- Support for multiple wake-up events (see Table 3-6-1).
- Support for a front panel power and sleep mode switch. Table 3-6-2 describes the system states based on how long the power switch is pressed, depending on how ACPI is configured with an ACPI-aware operating system.

#### Note

If you enable the ACPI function in the BIOS setup, the SMI switch function will not work.

### System States and Power States

Under ACPI, the operating system directs all system and device power state transitions. The operating system puts devices in and out of low-power states based on user preferences and knowledge of how devices are being used by applications. Devices that are not being used can be turned off. The operating system uses information from applications and user settings to put the system as a whole into a low-power state.

The table below describes which devices or specific events can wake the computer from specific states.

**Table 3-6-1: Wake Up Device and Events**

These device/events can wake up the computer.....	.....from this state
Power switch	Sleeping mode or power off mode
RTC alarm	Sleeping mode or power off mode
LAN	Sleeping mode or power off mode
Modem	Sleeping mode or power off mode
IR command	Sleeping mode
USB	Sleeping mode
PS/2 keyboard	Sleeping mode
PS/2 mouse	Sleeping mode

Table 3-6-2: Effect of Pressing the Power Switch

If the system is in this state.....	.....and the power switch is pressed for	.....the system enters this state
Off	Less than four seconds	Power on
On	More than four seconds	Soft off/Suspend
On	Less than four seconds	Fail safe power off
Sleep	Less than four seconds	Wake up

**ACPI Suspend Type:**

Two options are available: S1 (PowerOn-Suspend) → S3 (Suspend-To-RAM). The default setting is *S1 (PowerOn-Suspend)*. Generally, ACPI has six states: System S0 state, S1 state, S2 state, S3 state, S4 state, S5 state. S1 and S3 states are described below:

**The S1 (POS) State (POS means Power On Suspend):**

While the system is in the S1 sleeping state, its behavior is as described below:

- The processor is not executing instructions. The processor's complex context is maintained.
- Dynamic RAM context is maintained.
- Power Resources are in a state compatible with the system S1 state. All Power Resources that supply a System Level reference of S0 are in the OFF state.
- Devices states are compatible with the current Power Resource states. Only devices which solely reference Power Resources which are in the ON state for a given device state can be in that device state. In all other cases, the device is in the D3 (off) state.
- Devices that are enabled to wake the system and that can do so from their current device state can initiate a hardware event which transitions the system state to S0. This transition causes the processor to continue execution where it left off.

To transition into the S1 state, the operating software does not have to flush the processor's cache.

**The S3 (STR) State (STR means Suspend to RAM):**

The S3 state is logically lower than the S2 state and is assumed to conserve more power. The behavior of this state is defined as follows:

- Processor is not executing instructions. The processor complex context is not maintained.
- Dynamic RAM context is maintained.
- Power Resources are in a state compatible with the system S3 state. All Power Resources that supply a System Level reference of S0, S1, or S2 are in the OFF state.
- Devices states are compatible with the current Power Resource states. Only devices which solely reference Power Resources which are in the ON state for a given device state can be in that device state. In all other cases, the device is in the D3 (off) state.
- Devices that are enabled to wake the system and that can do so from their current device state can initiate a hardware event which transitions the system state to S0. This transition causes the processor to begin execution at its boot location. The BIOS performs initialization of core functions as required to exit an S3 state and passes control to the firmware resume vector. Please see the ACPI Specification

Rev. 1.0 book section 9.3.2 for more details on BIOS initialization.

From the software point of view, this state is functionally the same as the S2 state. The operational difference can be that some Power Resources that could be left ON in the S2 state might not be available to the S3 state. As such, additional devices can be required to be in logically lower D0, D1, D2, or D3 state for S3 than S2. Similarly, some device wake events can function in S2 but not S3.

Because the processor context can be lost while in the S3 state, the transition to the S3 state requires that the operating software flush all dirty cache to DRAM.

★ *Above information for system S1 were refer to ACPI Specification Rev. 1.0.*

---

#### **Modem Use IRQ:**

Eight items available: NA → 3 → 4 → 5 → 7 → 9 → 10 → 11 → Back to NA. The default setting is NA. You can specify the IRQ for modem use.

---

#### **HDD Off After:**

Sixteen options are available: Disable → 1 Min → 2 Min → 3 Min → 4 Min → 5 Min → 6 Min → 7 Min → 8 Min → 9 Min → 10 Min → 11 Min → 12 Min → 13 Min → 14 Min → 15 Min. The default setting is *Disable*.

---

#### **Power Button Override:**

Two items available: Instant Off → Delay 4 Sec. The default setting is *Instant Off*. It is activated when the user presses the power button for more than four seconds while the system is in the working state, then the system will transition to soft-off (Power off by software). This is called the power button over-ride.

---

#### **Power State Resume Control:**

This setting lets you set the system action after a power failure. Three options are available: Always Off → Always On → Keep Pre-State. The default setting is *Always Off*. This item lets you set the system power state when power recovers. If you set it to *Always Off*, when power returns, whatever state your computer was in before the power failure, the system will always turn off. If you set it to *Always On*, when power returns, whatever state your computer was in before the power failure, the system will always turn on. If you set it to *Keep Pre-State*, when the power returns, the computer return to the previous power state.

## PM Wake Up Events

The following is a list of IRQ's (Interrupt ReQuests) and list of the events. When an I/O device wants to gain the attention of the operating system, it causes an IRQ or event to occur. When the operating system is ready to respond to the request, it interrupts itself and performs the service.

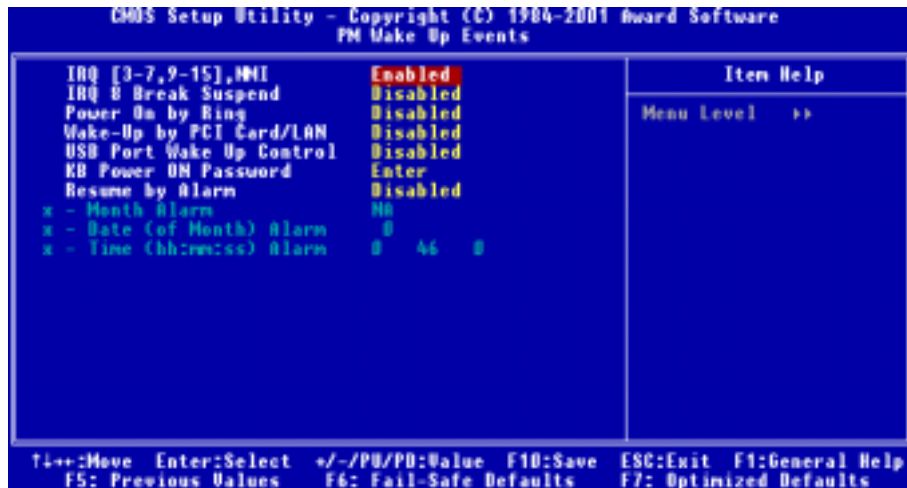

Figure 3-7B. PM Wake Up Events Screen Shot

### IRQ [3-7, 9-15], NMI:

Two options are available: Disabled or Enabled. The default setting is *Enabled*. When set to *Enabled*, any event occurring at a IRQ 3 ~ IRQ 7, IRQ 9 ~ IRQ 15 will awaken a system that has powered down.

### IRQ 8 Break Suspend:

Two options are available: Disabled or Enabled. The default setting is *Disabled*. When set to *Enabled*, any event occurring at a IRQ8 will awaken a system that has powered down.

### Power On by Ring:

Two options are available: Enabled or Disabled. The default setting is *Disabled*. When set to *Enabled*, any event affecting the modem (external modem) ring will awaken a system that has powered down.

### Wake-Up by PCI Card/LAN:

Two options are available: Enabled or Disabled. The default setting is *Disabled*. When set to *Enabled*, any event affecting PCI card (through the PCI PME internal pin) will awaken a system that has powered down.

### USB Port Wake Up Control:

Two options are available: Disabled or Enabled. The default setting is *Disabled*. When set to *Enabled*, any event occurring at a USB port will awaken a system that has powered down.

**KB Power ON Password:**

This item let you set the password for keypad wakeup. After you set the password, any event affecting keypad will awaken a system that has powered down.

**Resume by Alarm:**

Two options are available: Disabled or Enabled. The default setting is *Disabled*. When set to *Enabled*, you can set the month, date and time alarm at which the RTC (real-time clock) alarm awakens the system from Suspend mode. The enable items will appear white in color and disabled items will show a blue green color.

☛ **Month Alarm:**

Thirteen options are available: NA → 1 → 2 → 3 → 4 → 5 → 6 → 7 → 8 → 9 → 10 → 11 → 12. The default setting is *NA*. This field is not available to enter when the “*Resume by Alarm*” field is *Disabled*.

☛ **Date (of Month) Alarm:**

You can enter the decimal number from 1 to 31, which means the date of 1 to date of 31. This field is not available to enter when the “*Resume by Alarm*” field is set to *Disabled*.

☛ **Time (hh:mm:ss) Alarm:**

You can set the Time Alarm (hh:mm:ss). Any event occurring will awaken a system that has powered down. This field is not available to enter when the “*Resume by Alarm*” field is set to *Disabled*.

## 3-7. PnP/PCI Configurations Setup Menu

In this menu, you can change the INT# and IRQ# of the PCI bus and other hardware settings.

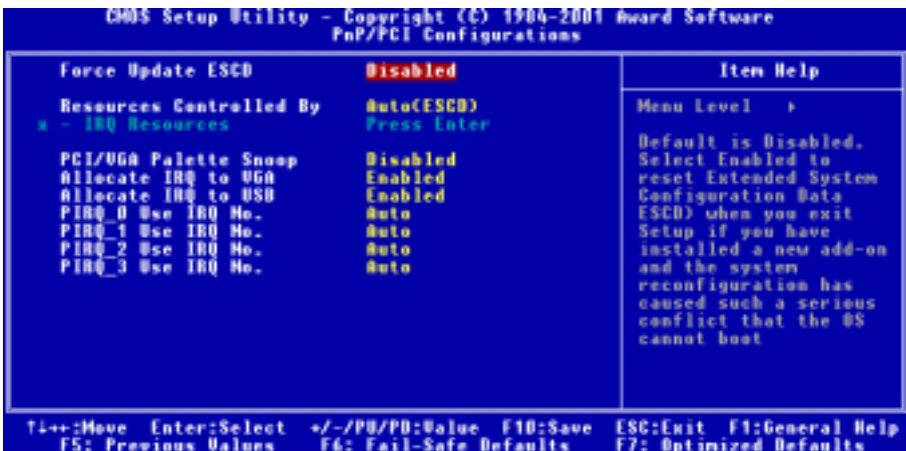

Figure 3-8A. PnP/PCI Configurations Screen Shot

**Force Update ESCD:**

Two options are available: Disabled or Enabled. The default setting is *Disabled*. Normally, you should leave this field Disabled. Select Enabled to reset Extended System Configuration Data (ESCD) when you exit Setup if you have installed a new add-on and the system reconfiguration has caused a serious conflict that prevents the operating system from booting.

**Computer Knowledge: ESCD (Extended System Configuration Data)**

The ESCD contains the IRQ, DMA, I/O port, memory information of the system. This is a specification and a feature specific to the Plug & Play BIOS.

**Resources Controlled By:**

When resources are controlled manually, assign each system interrupt as one of the following types, depending on the type of device using the interrupt:

*Legacy ISA* devices compliant with the original PC AT bus specification require a specific interrupt (such as IRQ4 for serial port 1). *PCI PnP* devices comply with the Plug and Play standard, whether designed for the PCI or legacy ISA bus architecture.

Two options are available: Auto (ESCD) or Manual. The default setting is *Auto (ESCD)*. The Award Plug and Play BIOS has the capability to automatically configure all boot and Plug and Play compatible devices. If you select Auto (ESCD), all of the interrupt request (IRQ) fields become unselectable, as the BIOS automatically assigns them.

**► IRQ Resources:**

If you have trouble in assigning the interrupt resources automatically, you can select *Manual* to set which IRQs are assigned to which *PCI Device* or *Reserved* it. See the screen shot below.

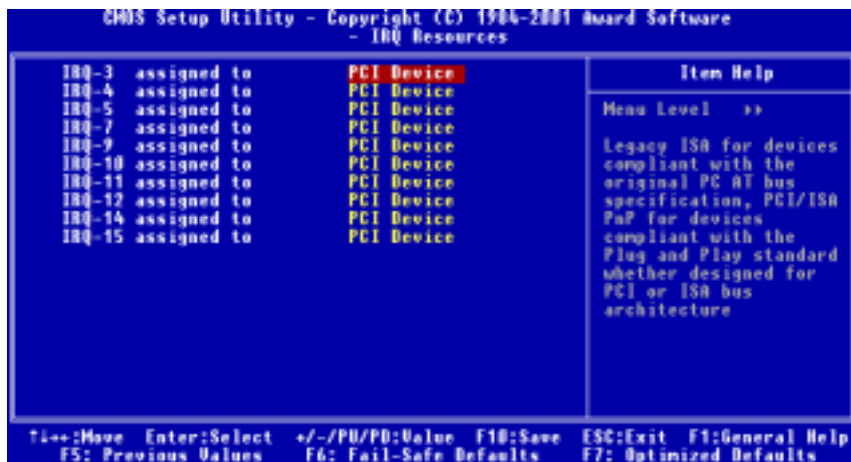

Figure 3-8B. IRQ Resources Screen Shot

**PCI/VGA Palette Snoop:**

Two options are available: Disabled or Enabled. The default setting is *Disabled*. This option allows the BIOS to preview VGA Status, and to modify the information delivered from the Feature Connector of the VGA card to the MPEG Card. This option can set the display inversion to black after you have used the MPEG card.

**Allocate IRQ to VGA:**

Two options are available: Disabled or Enabled. The default setting is *Enabled*. Name the interrupt request (IRQ) line assigned to the USB/VGA/ACPI (if any) on your system. Activity of the selected IRQ always awakens the system.

You can assign an IRQ for the either PCI or AGP VGA or *Disabled*.

**Allocate IRQ to USB:**

Two options are available: Disabled or Enabled. The default setting is *Enabled*. If you need free up another IRQ, you can choose to disable this item to an IRQ. However, some situations in Windows® 95 may cause the USB port to malfunction or experience other problems!

**PIRQ 0 Use IRQ No. ~ PIRQ 3 Use IRQ No.:**

Eleven options are available: Auto → 3 → 4 → 5 → 7 → 9 → 10 → 11 → 12 → 14 → 15. Default setting is *Auto*. This item allows the system to automatically specify the IRQ number for the device installed on PCI slots. This means that the system can specify the fixed IRQ number for the device installed on the PCI slots (PCI slot 1 to PCI slot 5). This is a useful function for when you want to fix the IRQ for a specific device.

For example, if you want to move your hard disk to another computer and don't want to re-install Windows® NT or Windows® 2000, you can simply specify the IRQ for the device installed on the new computer to fit the original computer settings.

This feature is for the operating system that will record and fix the PCI configuration status if you want to change it.

For the relations between the hardware layout of PIRQ (the signals from the SiS 961 chipset), INT# (means PCI slot IRQ signals) and devices, please refer to the table below:

SIGNALS	PCI Slot 1	PCI Slot 2	PCI Slot 3	PCI Slot 4	PCI Slot 5
<b>PIRQ 0 Assignment</b>	INT A	INT B	INT B	INT D	INT C
<b>PIRQ 1 Assignment</b>	INT B	INT D	INT A	INT A	INT D
<b>PIRQ 2 Assignment</b>	INT C	INT C	INT D	INT B	INT A
<b>PIRQ 3 Assignment</b>	INT D	INT A	INT C	INT C	INT B

- USB used INT D.
- Each PCI slot has four INT#s (INT A~INT D), and the AGP slot has two INT# (INTA and INT B).

<b>Note</b>
-------------

- PCI slot 1 shares IRQ signals with the AGP slot.
- PCI-4 and USB controllers share an IRQ.
- If you want to install two PCI cards into those PCI slots that share IRQ with one another at the same time, you must make sure that your OS and PCI devices' driver supports the IRQ sharing function.

### 3-8. PC Health Status

You can set the warning and shutdown temperatures for your computer system, and you can check the fan speeds and power supply voltages of your computer system. The features are useful for monitoring all the important parameters within your computer system. We call it the *PC Health Status*.



Figure 3-9. PC Health Status Screen Shot

#### CPU Warning Temperature:

Eight options are available: Disabled → 50°C/122°F → 53°C/127°F → 56°C/133°F → 60°C/140°F → 63°C/145°F → 66°C/151°F → 70°C/158°F. The default setting is *Disabled*. You can set the processor warning temperature here. If the processor temperature exceeds the settings value, the system will give you an alarm message or sound to remind you that the processor is overheating.

---

**CPU Shutdown Temperature:**

Five options are available: Disabled → 60°C/140°F → 65°C/149°F → 70°C/158°F → 75°C/167°F. The default setting is *Disabled*. You can set the processor shutdown temperature here. If the processor temperature exceeds the settings value, the system will shutdown immediately to prevent the processor from overheating.

---

**All Voltages, Fans Speed and Thermal Monitoring:**

These items list the current states of the processor and environment (using RT1 to detect them.) temperatures as well as fan speeds (processor fan and chassis fan). It can't be changed by the user.

The following items list the voltage states of the system power. It is also unchangeable.

<b>Note</b>
-------------

The hardware monitoring features for temperatures, fans and voltages will occupy the I/O address from 294H to 297H. If you have a network adapter, sound card or other add-on cards that might use those I/O addresses, please adjust your add-on card I/O address, to avoid the use of those addresses.
----------------------------------------------------------------------------------------------------------------------------------------------------------------------------------------------------------------------------------------------------------------------------------------------------------

---

### 3-9. Load Fail-Safe Defaults

When you press <Enter> on this item you get a confirmation dialog box with a message similar to:

**Load Fail-Safe Defaults (Y/N)? N**

Pressing “Y” loads the BIOS default values for the most stable, minimal-performance system operations.

---

### 3-10. Load Optimized Defaults

When you press <Enter> on this item you get a confirmation dialog box with a message similar to:

**Load Optimized Defaults (Y/N)? N**

Pressing “Y” loads the default values that are factory settings for optimal performance system operations.

---

## 3-11. Set Password

---

**Set Password:** Can enter but do not have the right to change the options of the setup menus. When you select this function, the following message will appear at the center of the screen to assist you in creating a password.

**ENTER PASSWORD:**

Type the password, up to eight characters in length, and press <Enter>. The password typed now will clear any previously entered password from CMOS memory. You will be asked to confirm the password. Type the password again and press <Enter>. You may also press <Esc> to abort the selection and not enter a password.

To disable a password, just press <Enter> when you are prompted to enter the password. A message will confirm the password will be disabled. Once the password is disabled, the system will boot and you can enter Setup freely.

**PASSWORD DISABLED.**

When a password has been enabled, you will be prompted to enter it every time you try to enter Setup. This prevents an unauthorized person from changing any part of your system configuration. Additionally, when a password is enabled, you can also require the BIOS to request a password every time your system is rebooted. This would prevent unauthorized use of your computer. You determine when the password is required within the BIOS Features Setup Menu and its Security option. If the Security option is set to *System*, the password will be required both at boot and at entry to Setup. If you set to *Setup*, prompting only occurs when trying to enter Setup.

---

## 3-12. Save & Exit Setup

---

Pressing <Enter> on this item asks for confirmation:

**Save to CMOS and EXIT (Y/N)? Y**

Pressing “Y” stores the selections made in the menus in CMOS - a special section of memory that stays on after you turn your system off. The next time you boot your computer, the BIOS configures your system according to the Setup selections stored in CMOS. After saving the values the system is restarted again.

---

## 3-13. Exit Without Saving

---

Pressing <Enter> on this item asks for confirmation:

**Quit without saving (Y/N)? Y**

This allows you to exit Setup without storing in CMOS any change. The previous selections remain in effect. This exits the Setup utility and restarts your computer.



## Appendix A. SiS Chipset Drivers Installation for Windows® 98 SE & Windows® 2000

After you've installed Windows® 98 SE or Windows® 2000, you will need to install the SiS chipset drivers. Step by step instructions on how to do this are found in the following section.

### Note

After installing Windows® 98 SE & Windows® 2000, the quality of your display will be poor because it will be set to 640\*480 and 16 colors. For the best screen capture quality, install the VGA drivers and set the desktop to 800\*600 using True Color.

### Note

Under Windows® 2000 operating system you have to install the service pack 2 (SP2) or latest service pack to get the best system performance. You can download SP2 at Microsoft® WEB site.

### Note

Details of the Windows® 98 SE or Windows® 2000 operating system will not be mentioned in this manual. If you have any problems with Windows® 98 SE or Windows® 2000 installation, operation, or settings, please refer to your Windows® 98 SE or Windows® 2000 user's manual or other databases provided by Microsoft® Corporation.

Insert the SD series CD into your CD-ROM drive and it should execute the program automatically. If not, you can go to the CD location and execute the execution file at the main directory of the CD. After it has been executed you will see the screen below.



**Step 1:** Move the cursor to “VIA 4in1 Driver” and click on it. You will go to the next screen. (Windows® 98 SE & Windows® 2000)



**Step 2:** The SiS AGP driver setup InstallShield® wizard shows up, and it will go to the next screen for a while. (Windows® 98 SE)



**Step 2:** The SiS AGP driver setup InstallShield® wizard shows up, and it will go to the next screen for a while. (**Windows® 2000**)



**Step 5:** The program will start to install drivers the system needs. The installer will show the install progress percentage. (**Windows® 98 SE**)



**Step 3:** You will now see the welcome screen and its dialogue box. Click “Next>” to go on. (**Windows® 98 SE & Windows® 2000**)



**Step 4:** Program will start to install drivers the system needs. The installer will show the install progress percentage. (**Windows® 2000**)



**Step 4:** Now you can choose the destination location where you want to install the drivers. We suggest that you use the default folder as the destination location. After checking the folder click “Next>” button. (**Windows® 98 SE**)

#### Note

The version you see may differ, because we may change the drivers or change the CD version. If this happens, the version may be different with this picture, but the install process won't change at all.



**Step 6:** When the installation is complete, the installer will ask you to restart your computer. We suggest that you choose “**Yes, I want to restart my computer now.**” then click the “**Finish**” button to restart your computer to finish the driver updates. (**Windows® 98 SE**)



**Step 5:** When the installation is complete, the installer will ask you to restart your computer. We suggest that you choose “**Yes, I want to restart my computer now.**” then click the “**Finish**” button to restart your computer to finish the driver updates. (**Windows® 2000**)



## Appendix B. Installing The Winbond Hardware Monitor System

The Winbond hardware monitor system is a self-diagnostic system for PCs. It will protect PC hardware by monitoring several critical items including power supply voltage, CPU and system fan speeds, and CPU and system temperatures. These items are important for the operation of the system; errors may result in permanent damage to the PC. Once any item is out of its normal range, a warning message will pop up and remind the user to take proper measures.

The following description will tell you how to install the Winbond hardware monitor system and use it. Insert the SD series CD into your CD-ROM drive. It should execute the program automatically. If not, you can go to the CD location and execute the execution file from the main directory of this CD. After it is executed, you will see the screen below.



**Step 1:** Click "Utility" button.



**Step 3:** You will see the install shell wizard extracting files.



**Step 2:** Click "Windbond Hardware Monitor" button to start install the hardware monitor system utility.



**Step 4:** Then hardware doctor setup program is preparing the InstallShield® wizard to guide you to the rest of the setup process.



**Step 5:** The welcome screen and its dialogue box will appear. Click the “**Next>**” button to go on.

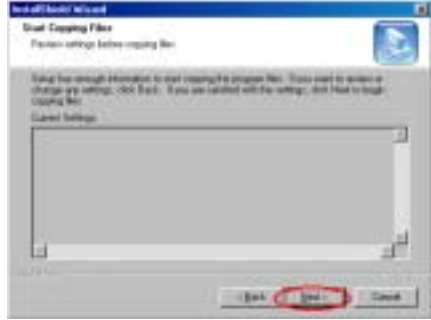

**Step 8:** The wizard will prepare to start install the program file. Click “**Next>**” button to go on.



**Step 6:** Now you can choose the destination location where you want to install the drivers. We suggest that you use the default folder as the destination location. After checking the folder click “**Next>**” button.

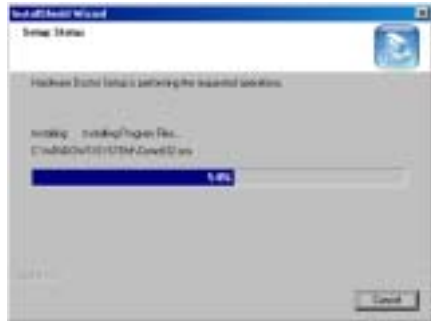

**Step 9:** Program will start to install drivers the system needs. The installer will show the install progress percentage.



**Step 7:** You can choose the name of the program folder. We suggest you use the default program folder name. After checking the program folder name then click “**Next>**” button.



**Step 10:** When the installation is complete, the installer will ask you to restart your computer. We suggest that you choose “**Yes, I want to restart my computer now.**” then click the “**Finish**” button to restart your computer to finish the driver update.



**Step 11:** You can select the program from Start toolbar, and then choose “**Programs**”. You will see the item called “**winbond**” → “**Hardware Doctor**”. Click it, and you will be able to see the screen below.

**Step 12:** This screen shows the hardware monitor system screen. It shows information about system temperature, voltages and fan speed. Some items can let you set the warning range; you can optimize values by setting them in accordance your system.

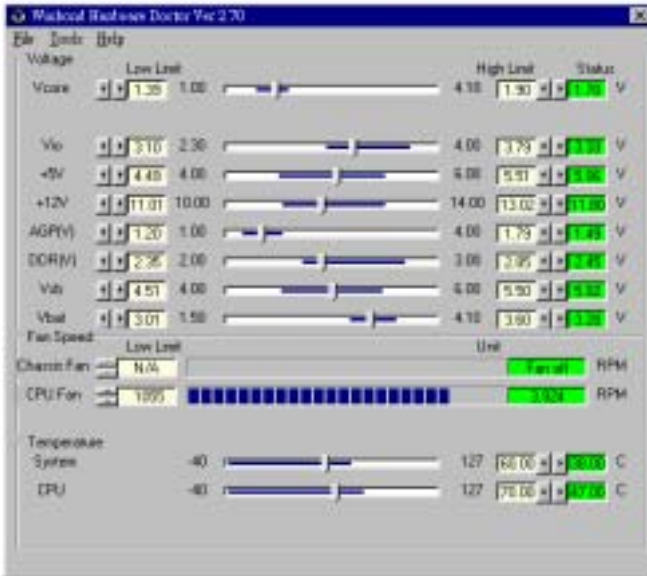



## Appendix C. Audio Drivers and Applications Installation for Windows® 98 SE & Windows® 2000

After you've installed SiS chipset drivers, you will need to install the audio drivers. Step by step instructions on how to do this are found in the following section.

### Note

Details of the Windows® 98 SE or Windows® 2000 operating system will not be mentioned in this manual. If you have any problems with Windows® 98 SE or Windows® 2000 installation, operations, or settings, please refer to your Windows® 98 SE or Windows® 2000 user's manual or other databases provided by Microsoft® Corporation.

### Note

Before you install the audio drivers and applications, please install the DirectX 8 first. The SD series CD had included DirectX 8 under “**Utility**”. Click the “Utility” button then you will see the “**DirectX 8**” button. Click it to start DirectX 8 installation, and the system will ask you to restart computer. When you restart again, you can start to install the audio drivers and applications. Please check the BIOS menu “**Integrated Peripherals**”, item “**Onboard Sound Controller**”, as this item need to be set to “**Enabled**” before you can start to install the audio drivers and applications.

Insert the SD series CD into your CD-ROM drive, and it should execute the program automatically. If not, you can go to the CD location and execute the execution file at the main directory of the CD. After it has been executed you will see the screen below.



**Step 1:** Move the cursor to “5.1 Channel Audio Driver” and click on it. You will go to the next screen. (Windows® 98 SE & Windows® 2000)



**Step 2:** The installation package select menu shows up. Please choose which item you want to install and click on it, and then you will go to the next screen. The in the example here we've chosen the item “**Install Device Driver and Applications**”. (Windows® 98 SE & Windows® 2000)

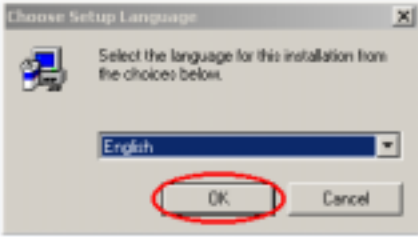

**Step 3:** Choose the language you want and click on “OK” button, it will go to the next screen. (Windows® 98 SE & Windows® 2000)



**Step 4:** You will now see the InstallShield® wizard shows up. (Windows® 98 SE & Windows® 2000)

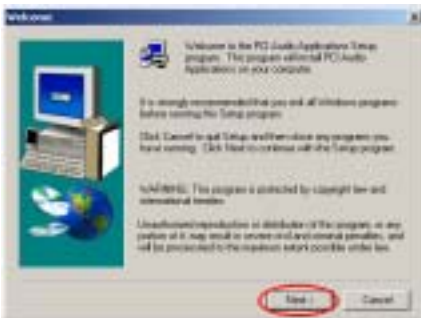

**Step 5:** The welcome screen and its dialogue box will appear. Click the “Next>” button to go on. (Windows® 98 SE & Windows® 2000)



**Step 6:** Now you can choose the destination location where you want to install the drivers. We suggest that you use the default folder as the destination location. After checking the folder click “Next>” button. (Windows® 98 SE & Windows® 2000)

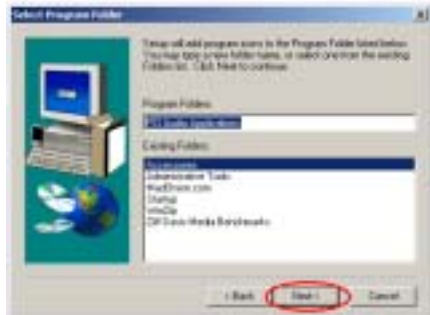

**Step 7:** You can choose the name of the program folder. We suggest you use the default program folder name. After checking the program folder name then click “Next>” button. (Windows® 98 SE & Windows® 2000)



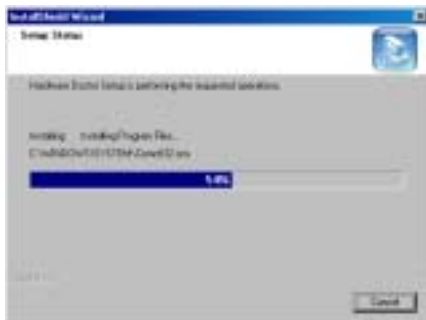

**Step 8:** Program will start to install drivers that the system needs. The installer will show the install progress percentage. (**Windows® 98 SE & Windows® 2000**)



**Step 9:** When installation is complete, the program will start to update the system information and drivers. This action will take a few minutes. In the process, you may ask to insert the Windows® 98 Second Edition CD-ROM into the CD-ROM drive. Follow the instructions shown on the screen and you will finish the update. (**Windows® 98 SE**)



**Step 9:** When the installation is complete, the installer will ask you to restart your computer. We suggest that you choose “**Yes, I want to restart my computer now.**” Then click the “**OK**” button to restart your computer to finish the driver update. (**Windows® 2000**)



**Step 10:** When the installation is complete, the installer will ask you to restart your computer. We suggest that you choose “**Yes, I want to restart my computer now.**” then click the “**OK**” button to restart your computer to finish the driver update. (**Windows® 98 SE**)



**Step 11:** The channel select menu shows up. Please select the suitable item according to the appropriate speaker number. This example shows selected “**5.1 CH**”. After choosing the channel, click “**Exit**” to restart the computer. (**Windows® 98 SE & Windows® 2000, for Windows® 2000 is Step 10**)



**Step 12:** When system restarts and enters the operating system, you can go to “**System Properties**” then check the “**Device Manager**” see that the devices are properly installed. (Windows® 98 SE)



**Step 11:** When system restarts and enters the operating system, you can then check the “**Device Manager**” see that the devices are

properly installed. (Windows® 2000)



**Step 13:** You can choose from “**Start**”, “**Programs**” then from item “**PCI Audio Applications**” to see the applications and demo program. You can quickly start the mixer panel by double click on the mixer icon in task bar. (Windows® 98 SE)

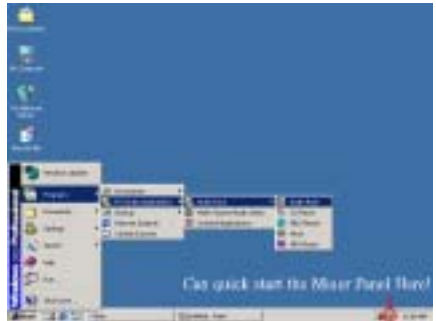

**Step 12:** You can choose from “**Start**”, “**Programs**” then from item “**PCI Audio Applications**” to see the applications and demo program. You can quickly start the mixer panel by double click on the mixer icon in task bar. (Windows® 2000)

We'll introduce several applications of **Audio Rack**. You can check them here or go to their help menu for more detailed information. We will now show you the most frequency used panel called "**Mixer Panel**". This panel can split into two parts depending on its function. One is called "**Volume Control Panel**", one is "**Record Control Panel**".



For each output signal, the control slider regulates the loudness whereas a horizontal slider the balance between the two speakers. The mute button can temporarily stop the output without changing slider positions. A button with a lit LED means the output is available, and vice versa. Several output signals can usually be enabled at once.

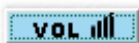

Pressing this button switches to the "**Volume Control Panel**".



Pressing this button switches to the "**Record Control Panel**".



Regulates the advanced settings. Discussed in a later section.

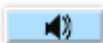

This is the master control over all outputs. The power of an output Re signal is determined by both of the volume slider and the slider for the individual output. To modify all the outputs, adjust the volume slider. To change individual output(s), adjust its (their) slider(s).



Regulates the CD drive audio input level.



Regulates the input level of microphone.

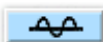

Regulates wave (voice) playback levels.

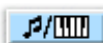

Regulates the MIDI music play level.

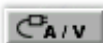

Regulates the Auxiliary input play level.

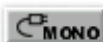

Regulates the Mono input level.



Regulates the Line-In levels.



**Exit Button:** Stops and leaves the mixer panel or the other panel you want to exit.



**About Button:** Shows software version and copyright information.



**Help Button:** Shows the help screen for detailed button function descriptions.



This horizontal slider used to adjust the balance between the two speakers.



Press the **REC** button to switch to the “**Record Control Panel**”.



Most buttons here have already been explained above, so we’ll explain the different function buttons below.



Regulates wave (voice) playback level.



Enables the recording from SPDIF in. SPDIF-in is mutually exclusive with other input signals.

Press the  button (advanced button) to switch to the “**Advanced**” menu. Here are several dialog folders allow you to determine item settings and adjustments.



**SPDIF** dialog provides a full control over SPDIF IN/OUT functions. You can use these settings to connect your computer to other audio devices, such as: Mini Disc players, amplifiers...etc. For detailed information, you can check the help dialogue box.



**Speakers** dialog provides an interface that allows you to set your speaker configuration. First, You should make sure what model type your speakers are, and what the correct configurations are. This dialog also shows the current status and functions of the phone jacks of your audio device. You can always refer to this to see whether or not the connections of your speakers and microphone are correct.



**Volume** dialog provides a full control over the volume of the six channel digital output. You can adjust the volume of your speakers in this dialog. Please note that the volume of analog path is not controlled by this function.

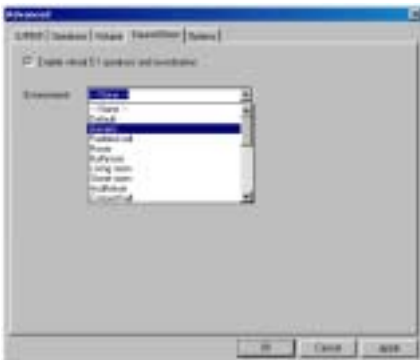

**Sound Effects** dialog allows you to modify the special effects of the songs and/or games being played. Currently, these effects can only be used for players or the games that utilize DirectSound 2D and 3D for music playback.



The **Options** dialog provides hot key settings to easily control the Mixer. Please note that other applications may be affected if you use the same hot key settings.

Please use “**Load Mixer Defaults**” to change all settings to default values.



The audio applications except the mixer, there still have CD player, MIDI player and MP3/Wave VCD player. If you choose the item “**Audio Rack**”, then you can see all the components of them. The figure above is Audio Rack panel.

This Audio Rack consists of several major components:

**Control Center:** Controls the display of the PCI Audio Rack components.



**CD Player** can play standard audio CDs, and allows you to create your own playlists.



**MIDI Player** can play MIDI files, \*.mid/\*.rmi, and allow you to create your own playlist.



**MP3/Wave Player** can play mp3, wave, and MPEG-1 files. It provides EAX and equalizer to improve sound effects when you playback audio files. If you want to sing a song, MP3/Wave Player also provides a Karaoke function. MP3/Wave Player can record input signals and save it in a wave file as well.



**Mixer** controls the volume level of your audio inputs and outputs.

We will explain the functions of three types player buttons below.



**Playlist:** You can select or move tracks of audio CD from and into the playlist. The title of CD and the name of tracks can be modified as well. The Playlist dialog will save and show them automatically when you want to play the same CD.



**Previous song:** Loads the previous track of playlist. If current track is the first track, the last track will become the current track.



**Next song:** Loads the next track of playlist. If current track is the last track, the first track will become the current track.



**Playback:** Starts to playback the current track.



**Pause/Restart:** Pauses or restarts the current playback action.



**Stop:** Stops playback.



**Playback backward for 10 seconds:** Playback the current to 10 seconds before.



**Playback forward for 10 seconds:** Playback the current to 10 seconds after.



**Sound effector:** You can use this function to modify the special effect of the song being played. Currently, these effectors can only be used for 44.1 KHz, 16-bit format.



**Recording:** You can use this function to record a wave file from any recording channel.



**Setting:** This button has different functions when use in different players. For example, if it is used in the CD player, you can select the CD-ROM drive to which analog output is connected to the Analog-CD in of your sound card. If your CD-ROM does not connect to the analog CD input wire, please use device manager to change the properties of your CD-ROM.



**Help:** Shows the help screen for detailed button function descriptions.



**About:** Shows the MP3, wave and VCD player software version and copyright information.



**About:** Shows the MIDI player software version and copyright information.



**About:** Shows the CD player software version and copyright information.



**Exit:** Stops and leaves the player that you choose.



**Loop:** Can playbacks the tracks over and over again.



**Eject:** Opens the CD-ROM drive to change the audio CD.

Every player has its own help button, so you can press this button to get more detailed information.



You can choose “**Multi-Channel Audio Demo**” to test the speakers and surround sound. The demonstration screen shown as left.

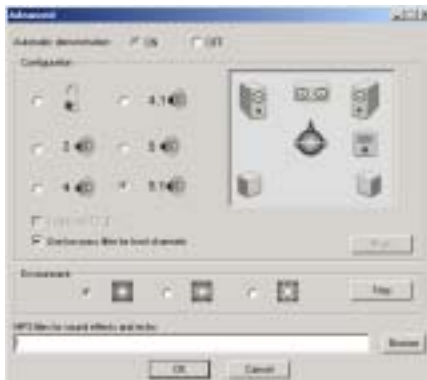

If you press the right button of mouse on the demonstration screen, you will see the advanced dialogue window. It can let you set speaker status and demo music.



## Appendix D. BIOS Update Guide

We will use the SE6 motherboard as an example. All other models follow the same process. First, know your motherboard's model name and version number. You can find it on one slot or at the back of the motherboard. Each motherboard always has the label at the same place as shown in the photo below.



You will find the model name and version on the white sticker.

2. Know the current BIOS ID.



For example, in this case, the current BIOS ID is "00". If you already have the latest BIOS, no any update action is necessary. If your BIOS is not the latest BIOS, go on to the next step.

3. Download the correct BIOS file from our Web site.

## [ SE6 ]

Filename:

[SE6SW.EXE](#)

Date: 07/06/2000

ID: SW

NOTE:

1. Fixes SCSI HDD detection problem when booting from SCSI CD-ROM and executing FDISK.
2. Supports 512MB memory modules.
3. Sets the In-Order Queue Depth default to 4, increasing the integrated video performance.

Go to our Web site and choose the correct BIOS file and download it.

4. Double click the download file, it will self-extract to .bin file.

```
LHA's SFX 2.13S (c) Yoshi, 1991
SE6_SW.BIN .....
```

5. Make a bootable floppy disk and copy the necessary files onto it.



You may make a floppy disk bootable either in Explorer or in the DOS prompt mode.

```
[c:\]format a: /s
```

After formatting and transferring the system to the floppy disk, copy two files into it. One is the BIOS flash utility “awdflash.exe” and the other is the decompressed BIOS binary file.

6. Boot off floppy disk.



Please set the first boot sequence as “floppy” in BIOS and boot off the floppy disk.

7. Flash the BIOS in pure DOS mode.

```
A:\>awdf flash se6_sw.bin /cc /cd /cp /py /sn /cks /r_
```

After successfully booting off of the floppy, execute the flash utility according to these instructions.

**Note**

We strongly recommend you use the above parameters following “awdf flash” to flash your BIOS. **DO NOT** just type “awdf flash se6\_sw.bin” without the above parameters following the .bin file.

**Note**

The Award flash utility can’t be completed under a Windows® 95/98 or Windows® NT environment, you must be in a pure DOS environment.

You should check which BIOS file is to be used with your motherboard, don't flash with the wrong BIOS file. Otherwise, you may cause system malfunctions.

**Note**

Please do not use the Award flash memory writer version that earlier than Version 7.52C to flash your SD7-533 motherboard BIOS. Otherwise, it may cause flash fail or un-anticipate problems.

**Note**

During the updating, the progress will be measured by white blocks. The last four *blue* blocks of the flash update process represent the “**BIOS boot block**”. The BIOS boot block is used to prevent the BIOS from becoming corrupt during programming. It should not be programmed every time. If this “**BIOS boot block**” remains intact when the BIOS becomes corrupt during programming, then you can boot from a bootable floppy next time you boot your computer. This allows you to flash your BIOS again without the need for technical support from the dealer.

---

## Appendix E. Troubleshooting (Need Assistance?)

---

### Motherboard Troubleshooting:

#### Q & A:

**Q: Do I need to clear the CMOS before I use a new motherboard to assemble my new computer system?**

A: Yes, we highly recommend that you clear the CMOS before installing a new motherboard. Please move the CMOS jumper from its default 1-2 position to 2-3 for a few seconds, and then back. When you boot up your system for the first time, follow the instructions in the user's manual to load the optimized defaults.

**Q: If my systems hang when I update the BIOS or set the wrong processor parameters, what should I do?**

A: Whenever you update the BIOS or if the system hangs due to wrong processor parameters setting, always clear CMOS jumper before booting up again.

**Q: How can I get a quick response to my request for technical support?**

A: Be sure to follow the guidelines as stated in the “**Technical Support Form**” section of this manual.

If you have a problem during operation, in order to help our technical support personnel quickly determine the problem with your motherboard and give you the answers you need, before filling in the technical support form, eliminate any peripheral that is not related to the problem, and indicate it on the form. Fax this form to your dealer or to the company where you bought the hardware in order to benefit from our technical support. (You can refer to the examples given below)



**Example 1:** With a system including: motherboard (with processor, DDR DRAM, etc.) HDD, CD-ROM, FDD, graphic adapter, MPEG-2 card, SCSI adapter, audio card, etc. After the system is assembled, if you cannot boot up, check the key components of the system using the procedure described below. First remove all interface cards except the VGA card and try to reboot.

☛ **If you still cannot boot up:**

Try installing another brand/model VGA card and see if the system will start. If it still does not start, note the VGA card model, motherboard model, Bios identification number, processor on the technical support form (refer to main instructions), and describe the problem in the problem description space provided.

☛ **If you can boot up:**

Insert the interface cards you have removed back into the system, one by one and try to start the system each time you insert a card, until the system will not start. Keep the VGA card and the interface card that caused the problem inserted on the motherboard, remove any other cards or peripheral, and start again. If you still cannot start, note the information related to both cards in the add-on card space provided, and don't forget to indicate the motherboard model, version, BIOS identification number, processor (refer to main instructions), and give a description of the problem.



**Example 2:** With a system including: motherboard (with processor, DDR DRAM, etc.) HDD, CD-ROM, FDD, graphic adapter, MPEG-2 card, SCSI adapter, audio card, etc. After assembly and after having installed the audio card driver, when you restart the system, when it runs the audio card driver, it resets automatically. This problem may be due to the audio card driver. During the starting DOS... procedure, press SHIFT (BY-PASS) key, to skip CONFIG.SYS and AUTOEXEC.BAT; edit CONFIG.SYS with a text editor, and in function the line that loads the audio card driver, add a remark REM, in order to disable the audio card driver. See the example below.

```
CONFIG.SYS:
DEVICE=C:\DOS\HIMEM.SYS
DEVICE=C:\DOS\EMM386.EXE HIGHSCAN
DOS=HIGH, UMB
FILES=40
BUFFERS=36
REM DEVICEHIGH=C:\PLUGPLAY\DWCFGMG.SYS
LASTDRIVE=Z
```

Restart the system. If the system starts and does not reset, you can be sure that the problem is due to the Sound Card Driver. Write down the Sound Card model, motherboard model, BIOS identification number on the technical support file (refer to main instructions), and describe the problem in the space provided.

We will show you how to fill the “**Technical Support Form**” right now.

### 🌀 Instructions 🌀

To fill in this “**Technical Support Form**”, refer to the step-by-step instructions given below:

- 1\*. **Model Name:** Note the model number given in your user’s manual.  
For example: SD7-533, KR7A, KR7A-RAID, etc...
- 2\*. **Motherboard PCB Version:** Note the motherboard PCB version labeled on the motherboard slot or back side as “**Rev:\*.\*\***”.  
For example: REV: 1.01
- 3\*. **BIOS ID & Part Number:** See *Appendix D* for detailed information.
4. **DriverVersion:** Note the driver version number indicated on the device driver disk or CD-ROM (if have) as “**Release \*.\***” (or Rev. \*.\*- , Version \*.\*). For example:

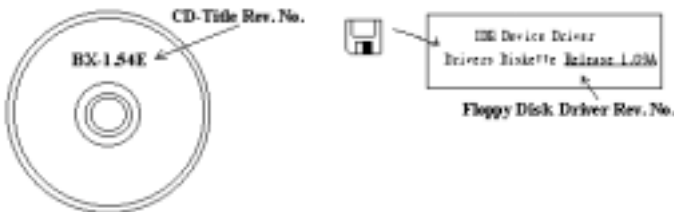

- 5\* **OS/Applications:** Indicate the operating system and the applications you are running on the system.  
 For example: Windows® 98 SE, Windows® 2000, Windows® XP, etc.
- 6\* **Processor Type:** Indicate the brand and the speed (MHz) of your processor.  
 For example: (A) In the “**Brand**” space, write “**Intel**”, in the “**Specifications**” space, write “**Pentium® 4 processor 2 GHz**”.
7. **Hard Disk Drive:** Indicate the brand and specifications of your HDD(s), specify if the HDD is using  IDE1 or  IDE2. If you know the disk capacity, indicate it and check (“✓”) “”; in case you give no indication, we will consider that your HDD is “IDE1” Master.  
 For example: In the “**Hard Disk Drive**” space, check the box, in the “**Brand**” space, write “**SEAGATE**”, in the “**Specifications**” space, write “**Darracuda ATA2 ST330631A (30 GB)**”.
8. **CD-ROM Drive:** Indicate the brand and specifications of your CD-ROM drive. Specify if it uses  IDE1 or  IDE2 and check (“✓”) “”; in case you give no indication, we will consider that your CD-ROM is “IDE2” Master.  
 For example: In the “**CD-ROM Drive**” space, check the box, in the “**Brand**” space, write “**Pioneer**”, in the “**Specifications**” space, write “**DVD-16**”.
9. **System Memory (DDR SDRAM):** Indicate the brand and specifications (DDR DIMM) of your system memory. Examples: Density, Description, Module Components, Module Part Number, CAS Latency, Speed (MHz). For example:  
 In the “**Brand**” space, write “**Micron**”, in the “**Specifications**” space, write:  
**Density:** 128MB, **Description:** SS 16 Megx72 2.5V ECC Gold, **Module Components:** (9) 16 Megx 8, **Module Part Number:** MT9VDDT1672AG, **CAS Latency:** 2, **Speed (MHz):** 200 MHz.  
 Please give us the detailed information of your DDR DIMM module, as it will help us to simulate the problems you met.
10. **Add-On Card:** Indicate which add-on cards you are *absolutely sure* are related to the problem.  
 If you can’t identify the problem’s origin, indicate all the add-on cards inserted into your system. Remember to identify which card insert on which slot.  
 For example: Creative SB Value sound card insert on PCI slot 3.
11. **Problem Description:** Please tell us problem you met. The more detailed, the better as our engineers can help to find the solution more quickly. If the problem is random occurrence, it may be hard to simulate the problem and may take more time to find a solution.

**Note**

Items between the “\*” are absolutely necessary.



---

## Appendix F. How to Get Technical Support

---

(From our website) <http://www.abit.com.tw>

(In North America) <http://www.abit-usa.com>

(In Europe) <http://www.abit.nl>

Thank you for choosing ABIT products. ABIT sells all our products through distributors, resellers and system integrators, we have no direct sales to end-users. Before sending email for tech support please check with your resellers or integrators if you need any services, they are the ones who sold you your system and they should know best as to what can be done, how they serve you is a good reference for future purchases.

We appreciate every customer and would like to provide the best service to you. Providing fast service to our customers is our top priority. However we receive many phone calls and a huge amount of email from all over the world. At the present time it is impossible for us to respond to every single inquiry. Therefore it is quite possible that if you send an email to us that you may not receive a response.

We have done many compatibility tests and reliability tests to make sure our products have the best quality and compatibility. In case you need service or technical support, please understand the constraint we have and **always check with the reseller who sold the product to you first.**

To expedite service, we recommend that you follow the procedures outlined below before contacting us. With your help, we can meet our commitment to provide the best service to the **greatest number of ABIT customers:**

1. **Check the Manual.** It sounds simple, but we have taken a lot of care in making a well-written and thorough manual. It is full of information that doesn't only pertain to motherboards. The CD-ROM included with your board will have the manual as well as drivers. If you don't have either one, go to the Program Download Area of our website or FTP server.
2. **Download latest BIOS, software or drivers.** Please go to our Program Download area on our website to check to see if you have the latest BIOS. They are developed over periods of time to fix bugs or incompatibilities. **Also please make sure you have the latest drivers from your peripheral cards makers!**
3. **Check the ABIT Technical Terms Guide and FAQ on our website.** We are trying to expand and make the FAQs more helpful and information rich. Let us know if you have any suggestions. For hot topics check out our HOT FAQ!
4. **Internet Newsgroups.** They are a great source of information and many people there can offer help. ABIT's Internet News group, **alt.comp.peripherals.mainboard.abit**, is an ideal forum for the public to exchange information and discuss experiences they have had with ABIT products. Many times you will see that your question has already been asked before. This is a public Internet news group and it is reserved for free discussions, Here is a list of some of the more popular ones:

[alt.comp.peripherals.mainboard.abit](http://alt.comp.peripherals.mainboard.abit)

[comp.sys.ibm.pc.hardware.chips](http://comp.sys.ibm.pc.hardware.chips)

[alt.comp.hardware.overclocking](http://alt.comp.hardware.overclocking)

[alt.comp.hardware.homebuilt](http://alt.comp.hardware.homebuilt)

[alt.comp.hardware.pc-homebuilt](http://alt.comp.hardware.pc-homebuilt)

**Ask your reseller.** Your ABIT authorized distributor should be able to provide the fastest solution to your technical problem. We sell our products through distributors who sell to resellers and stores. Your reseller should be very familiar with your system configuration and should be able to solve your problem much more efficiently than we could. After all, your reseller regards you as an important

customer who may purchase more products and who can urge your friends to buy from him or her as well. They integrated and sold the system to you. They should know best what your system configuration is and your problem. They should have reasonable return or refund policies. How they serve you is also a good reference for your next purchase.

- 5. Contacting ABIT.** If you feel that you need to contact ABIT directly you can send email to the ABIT technical support department. First, please contact the support team for the branch office closest to you. They will be more familiar with local conditions and problems and will have better insight as to which resellers offer what products and services. Due to the huge number of emails coming in every day and other reasons, such as the time required for problem reproduction, we will not be able to reply to every email. Please understand that we are selling through distribution channels and don't have the resources to serve every end-user. However, we will try to do our best to help every customer. Please also remember that for many of our technical support team English is a second language, you will have a better chance of getting a helpful answer if your question can be understood in the first place. Be sure to use very, simple, concise language that clearly states the problem, avoid rambling or flowery language and always list your system components. Here is the contact information for our branch offices:

**In North America and South America please contact:  
ABIT Computer (USA) Corporation**

46808 Lakeview Blvd.  
Fremont, California 94538, U.S.A.  
[sales@abit-usa.com](mailto:sales@abit-usa.com)  
[technical@abit-usa.com](mailto:technical@abit-usa.com)  
Tel: 1-510-623-0500  
Fax: 1-510-623-1092

**In the UK and Ireland:  
ABIT Computer Corporation Ltd.**

Unit 3, 24-26 Boulton Road  
Stevenage, Herts  
SG1 4QX, UK  
[abituksales@compuserve.com](mailto:abituksales@compuserve.com)  
[abituktech@compuserve.com](mailto:abituktech@compuserve.com)  
Tel: 44-1438-228888  
Fax: 44-1438-226333

**In Germany and Benelux (Belgium, Netherlands, Luxembourg) countries:  
AMOR Computer B.V. (ABIT's European Office)**

Van Coehoornstraat 7,  
5916 PH Venlo, The Netherlands  
[sales@abit.nl](mailto:sales@abit.nl)  
[technical@abit.nl](mailto:technical@abit.nl)  
Tel: 31-77-3204428  
Fax: 31-77-3204420

**All other territories not covered above please contact:****Taiwan Head Office**

When contacting our headquarters please note we are located in Taiwan and we are 8+ GMT time. In addition, we have holidays that may be different from those in your country.

**ABIT Computer Corporation**

3F-7, No. 79, Sec. 1, Hsin Tai Wu Rd.

Hsi Chi, Taipei Hsien, Taiwan

[sales@abit.com.tw](mailto:sales@abit.com.tw)

[market@abit.com.tw](mailto:market@abit.com.tw)

[technical@abit.com.tw](mailto:technical@abit.com.tw)

Tel: 886-2-2698-1888

Fax: 886-2-2698-1811

**RMA Service.** If your system has been working but it just stopped, but you have not installed any new software or hardware recently, it is likely that you have a defective component. Please contact the reseller from whom you bought the product. You should be able to get RMA service there.

- 6. Reporting Compatibility Problems to ABIT.** Because of tremendous number of email messages we receive every day, we are forced to give greater weight to certain types of messages than to others. For this reason, any compatibility problem that is reported to us, giving detailed system configuration information and error symptoms, will receive the highest priority. For the other questions, we regret that we may not be able to reply directly. But your questions may be posted to the internet news group in order that a larger number of users can have the benefit of the information. Please check the news group from time to time.
- 7.** Listed below are some chipset vendors' WEB site addresses for your reference:

ALI's WEB site: <http://www.ali.com.tw/>

AMD's WEB site: <http://www.amd.com/>

Highpoint Technology Inc.'s WEB site: <http://www.highpoint-tech.com/>

Intel's WEB site: <http://www.intel.com/>

SiS' WEB site: <http://www.sis.com.tw/>

VIA's WEB site: <http://www.via.com.tw/>

**Thank you, ABIT Computer Corporation**

**<http://www.abit.com.tw>**

