



Getting Started

Thank you for purchasing the MD-5000 M-ATX mainboard. The MD-5000 mainboard is based on SiS® 648 North Bridge & 963 South Bridge chipsets for optimal system efficiency. Designed to fit the advanced Intel® Pentium 4/Celeron processors in the 478 pin package, the MD-5000 mainboard delivers a high performance and professional desktop platform solution.

Information in this document is subject to change without notice.

Medion® shall not be liable for errors contained herein or for incidental or consequential damages in connection with the furnishing, performance, or use of this material.

Mainboard Specifications

CPU

- Supports Socket 478 for P4/Celeron processors (Willimote and Northwood core) with 400/533 MHz
- Core Frequency from 1.3 GHz to 2.8 GHz and up

Chipset

- SiS® 648 chipset
 - Supports Intel Pentium 4 processors with data transfer rate up to 533 MHz
 - Supports 64-bit high performance DDR333+/DDR333/DDR266 memory controller
 - Supports AGP 8X/4X interface
 - Supports bi-directional 16-bit data bus with 1 GHz bandwidth MuTIOL
- SiS® 963 chipset
 - Supports Dual-IDE ATA 66/100/133
 - Integrated audio controller with AC97 interface
 - Low pin count interface for SIO
 - Advanced power management and PC2001 compliance

Main Memory

- Supports two 184-pin DDR DIMMs
- Supports up to 2GB PC2700/2100/1600 DDR SDRAMs
- Supports 2.5v DDR SDRAM

Slots

- One AGP (Accelerated Graphics Port) 4x/8x slot.
- Three 32-bit PCI bus slots (support 3.3v/5v PCI bus interface).

On-Board IDE

- Dual-IDE controller integrated in SiS 963 chipset
- Supports PIO, Bus Master and Ultra DMA133/100/66/33 operation modes
- Can connect up to four IDE devices.

On-Board Peripherals

- On-Board Peripherals include:
 - 1 floppy port supports 2 FDDs with 360K, 720K, 1.2M, 1.44M and 2.88Mbytes
 - 1 serial port

- 1 parallel port
- Audio * 3 in vertical for 6 channels Line-out, 2 in vertical for MIC & Line-in
- 1 standard 1394 connector
- 1 mini 1394 connector
- 5 USB ports (3 front + 2 rear)
- 1 RJ-45 Lan Jack (optional)
- PS2 KB/Mouse

OnboardIEEE1394

- ▶ Integrated in SiS 963 SB
- ▶ AGREE FW803

Audio

- ▶ S/W RealTek ALC650 6-channel audio codec with SPDIF in/out

LAN

- ▶ Realtek RTL8201BL

BIOS

- ▶ The mainboard BIOS provides “Plug & Play” BIOS which detects the peripheral devices and expansion cards of the board automatically.
- ▶ The mainboard provides a Desktop Management Interface (DMI) function which records your mainboard specifications.

Dimension

- ▶ M-ATX Form Factor: 24.4 cm x 23.0 cm

Mounting

- ▶ 6 mounting holes.

Others

- ▶ Suspend to RAM/Disk (S3/S4)
- ▶ PC2001 compliant
- ▶ Chassis Intrusion Detection

Mainboard Layout

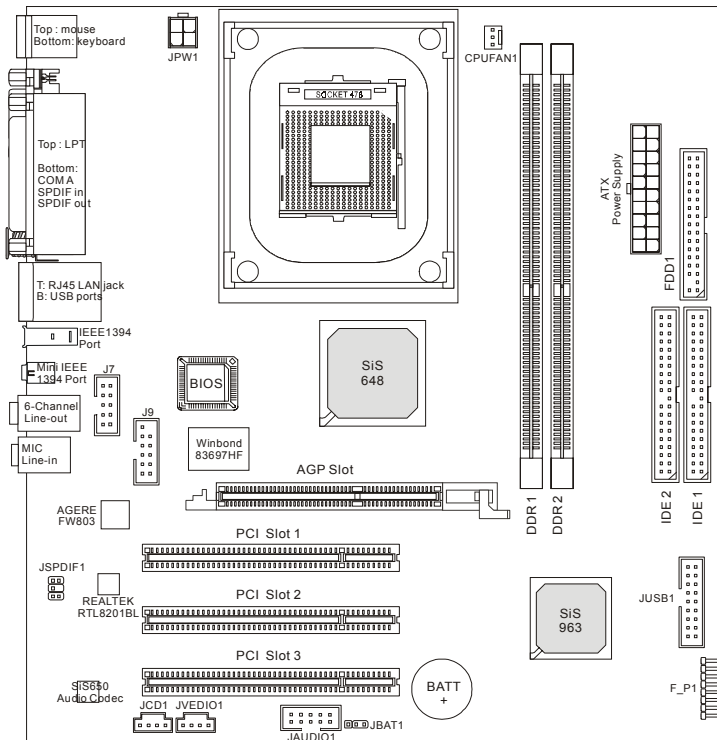

MD-5000 M-ATX Mainboard

2

Hardware Setup

This chapter tells you how to install the CPU, memory modules, and expansion cards, as well as how to setup the jumpers on the mainboard. Also, it provides the instructions on connecting the peripheral devices, such as the mouse, keyboard, etc.

While doing the installation, be careful in holding the components and follow the installation procedures.

Quick Components Guide

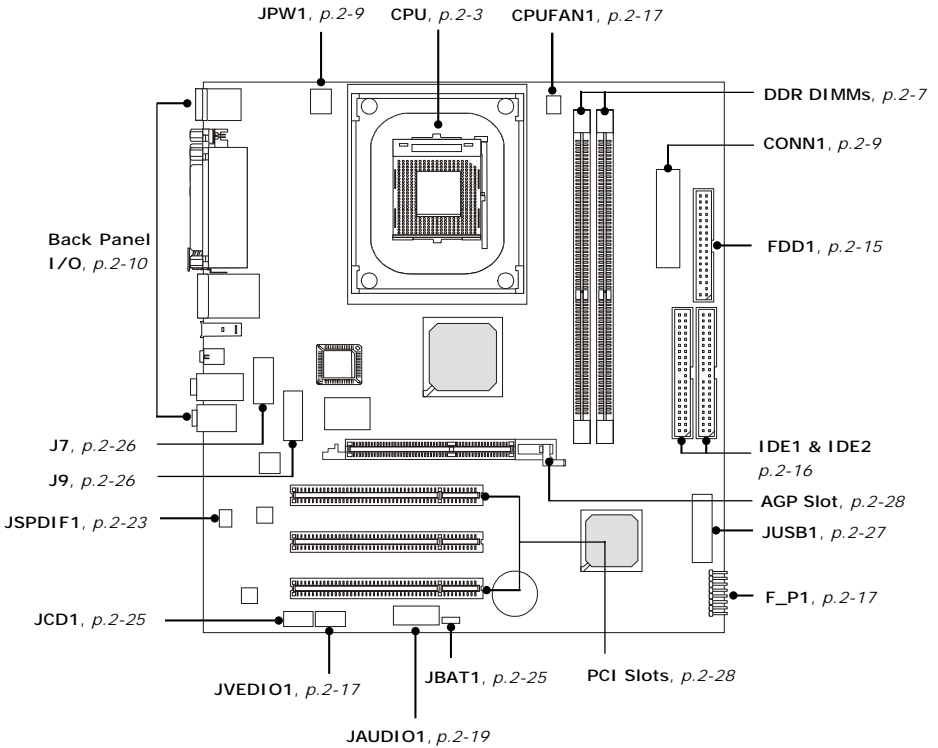

Central Processing Unit: CPU

The mainboard supports Intel® Pentium® 4 processor in the 478 pin package. The mainboard uses a CPU socket called PGA478 for easy CPU installation. When you are installing the CPU, **make sure the CPU has a heat sink and a cooling fan attached on the top to prevent overheating.** If you do not find the heat sink and cooling fan, contact your dealer to purchase and install them before turning on the computer.

CPU Core Speed Derivation Procedure

If	CPU Clock	=	100MHz
	Core/Bus ratio	=	14
then	CPU core speed	=	Host Clock x Core/Bus ratio
		=	100MHz x 14
		=	1.4 GHz



MSI Reminds You...

Overheating

Overheating will seriously damage the CPU and system, always make sure the cooling fan can work properly to protect the CPU from overheating.

Replacing the CPU

While replacing the CPU, always turn off the ATX power supply or unplug the power supply's power cord from grounded outlet first to ensure the safety of CPU.

CPU Installation Procedures for Socket 478

1. Please turn off the power and unplug the power cord before installing the CPU.
2. Pull the lever sideways away from the socket. Make sure to raise the lever up to a 90-degree angle.
3. Look for the gold arrow. The gold arrow should point towards the lever pivot. The CPU can only fit in the correct orientation.
4. If the CPU is correctly installed, the pins should be completely embedded into the socket and can not be seen. Please note that any violation of the correct installation procedures may cause permanent damages to your mainboard.
5. Press the CPU down firmly into the socket and close the lever. As the CPU is likely to move while the lever is being closed, always close the lever with your fingers pressing tightly on top of the CPU to make sure the CPU is properly and completely embedded into the socket.

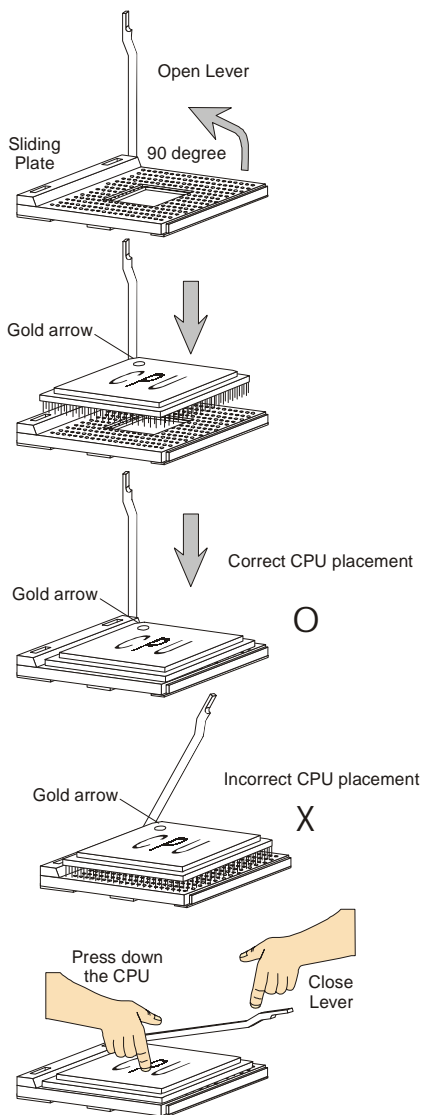

Memory

The mainboard provides 2 slots for 184-pin DDR SDRAM DIMM (Double In-Line Memory Module) modules and supports the memory size up to 2GB. You can install DDR200/266/333 modules on the DDR DIMM slots (DIMM 1~2).

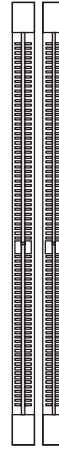
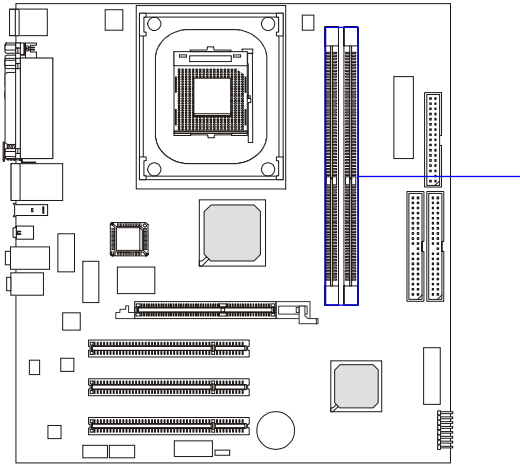

**DDR DIMM Slots
(DDR 1~2)**

DIMM Module Combination

Install at least one DIMM module on the slots. You can install either single- or double-sided modules in any order to meet your own needs.

Memory modules can be installed in any combination as follows:

Slot	Memory Module	Total Memory
DIMM 1 (Bank 0 & 1)	S/D	64MB~1GB
DIMM 2 (Bank 2 & 3)	S/D	64MB~1GB
Maximum System Memory Supported		64MB~2GB

S: Single Side

D: Double Side

Installing DDR Modules

1. The DDR DIMM has only one notch on the center of module. The module will only fit in the right orientation.
2. Insert the DIMM memory module vertically into the DIMM slot. Then push it in until the golden finger on the memory module is deeply inserted in the socket.
3. The plastic clip at each side of the DIMM slot will automatically close.

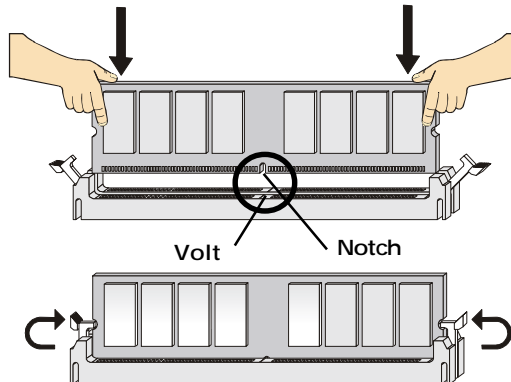

MSI Reminds You...

You can barely see the golden finger if the module is properly inserted in the socket.

Power Supply

The mainboard supports ATX power supply for the power system. Before inserting the power supply connector, always make sure that all components are installed properly to ensure that no damage will be caused.

ATX 20-Pin Power Connector: CONN1

This connector allows you to connect to an ATX power supply. To connect to the ATX power supply, make sure the plug of the power supply is inserted in the proper orientation and the pins are aligned. Then push down the power supply firmly into the connector.

ATX 12V Power Connector: JPW1

This 12V power connector is used to provide power to the CPU.

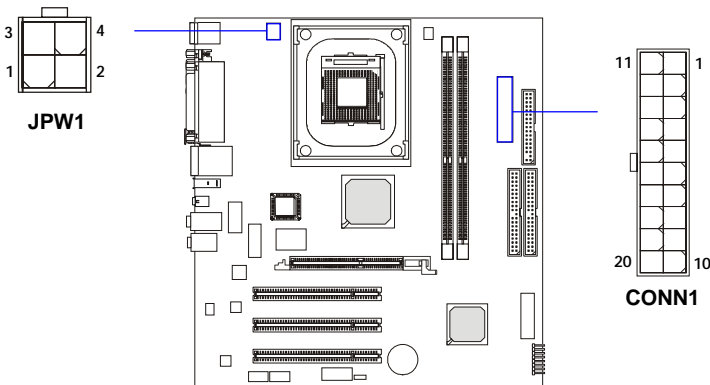

CONN1 Pin Definition

PIN	SIGNAL	PIN	SIGNAL
1	3.3V	11	3.3V
2	3.3V	12	-12V
3	GND	13	GND
4	5V	14	PS_ON
5	GND	15	GND
6	5V	16	GND
7	GND	17	GND
8	PW_OK	18	-5V
9	5V_SB	19	5V
10	12V	20	5V

JPW1 Pin Definition

PIN	SIGNAL
1	GND
2	GND
3	12V
4	12V

Back Panel

The back panel provides the following connectors:

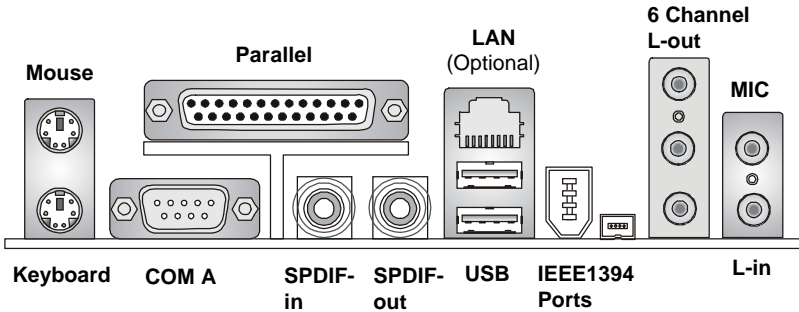

Mouse Connector

The mainboard provides a standard PS/2[®] mouse mini DIN connector for attaching a PS/2[®] mouse. You can plug a PS/2[®] mouse directly into this connector. The connector location and pin assignments are as follows:

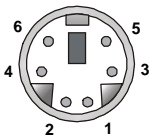

PS/2 Mouse (6-pin Female)

Pin Definition

PIN	SIGNAL	DESCRIPTION
1	Mouse DATA	Mouse DATA
2	NC	No connection
3	GND	Ground
4	VCC	+5V
5	Mouse Clock	Mouse clock
6	NC	No connection

Keyboard Connector

The mainboard provides a standard PS/2[®] keyboard mini DIN connector for attaching a PS/2[®] keyboard. You can plug a PS/2[®] keyboard directly into this connector.

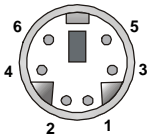

PS/2 Keyboard (6-pin Female)

Pin Definition

PIN	SIGNAL	DESCRIPTION
1	Keyboard DATA	Keyboard DATA
2	NC	No connection
3	GND	Ground
4	VCC	+5V
5	Keyboard Clock	Keyboard clock
6	NC	No connection

USB Connectors

The mainboard provides an OHCI (Open Host Controller Interface) Universal Serial Bus root for attaching USB devices such as keyboard, mouse or other USB-compatible devices. You can plug the USB device directly into the connector.

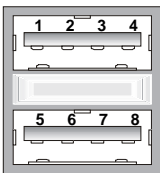

USB Ports

USB Port Description

PIN	SIGNAL	DESCRIPTION
1	VCC	+5V
2	-Data 0	Negative Data Channel 0
3	+Data0	Positive Data Channel 0
4	GND	Ground
5	VCC	+5V
6	-Data 1	Negative Data Channel 1
7	+Data 1	Positive Data Channel 1
8	GND	Ground

Parallel Port Connector: LPT1

The mainboard provides a 25-pin female centronic connector as LPT. A parallel port is a standard printer port that supports Enhanced Parallel Port (EPP) and Extended Capabilities Parallel Port (ECP) mode.

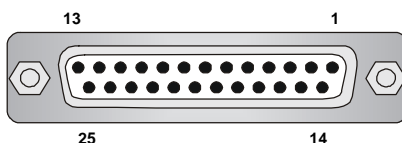

Pin Definition

PIN	SIGNAL	DESCRIPTION
1	STROBE	Strobe
2	DATA0	Data0
3	DATA1	Data1
4	DATA2	Data2
5	DATA3	Data3
6	DATA4	Data4
7	DATA5	Data5
8	DATA6	Data6
9	DATA7	Data7
10	ACK#	Acknowledge
11	BUSY	Busy
12	PE	Paper End
13	SELECT	Select
14	AUTO FEED#	Automatic Feed
15	ERR#	Error
16	INIT#	Initialize Printer
17	SLIN#	Select In
18	GND	Ground
19	GND	Ground
20	GND	Ground
21	GND	Ground
22	GND	Ground
23	GND	Ground
24	GND	Ground
25	GND	Ground

RJ-45 LAN Jack (Optional)

The mainboard provides a RJ-45 connector that allows your computer to be connected to a network environment.

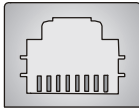

LAN Jack
(RJ-45)

Pin	Signal	Description
1	TDP	Transmit differential pair
2	TDN	Transmit differential pair
3	RDP	Receive differential pair
4	NC	Not used
5	NC	Not used
6	RDN	Receive differential pair
7	NC	Not used
8	NC	Not used

Audio Port Connectors

Line Out is a connector for Speakers or Headphones. **Line In** is used for external CD player, Tape player, or other audio devices. **Mic** is a connector for microphones.

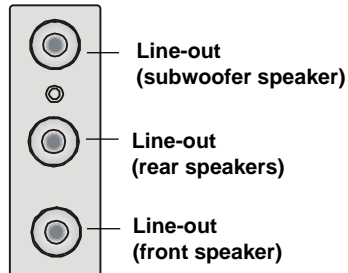
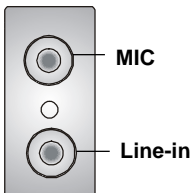

MSI Reminds You...

For advanced audio application, **RealTek ALC650 audio chip is provided as an option** to offer support for **6-channel audio operation** and can turn rear audio connectors from 2-channel to 4-/6-channel audio.

IEEE1394 Ports

The mainboard provides two IEEE 1394 ports. The mini IEEE1394 port is designed for you to connect the IEEE1394 device with external power. The standard IEEE1394 port connects to IEEE1394 devices without external power. The IEEE1394 high-speed serial bus complements USB by providing enhanced PC connectivity for a wide range of devices, including consumer electronics audio/video (A/V) appliances, storage peripherals, other PCs, and portable devices.



**IEEE1394 Port
(Standard)**



**IEEE1394 Port
(Mini)**

SPDIF Connectors

The SPDIF connectors provided on the back panel can be used to connect your digital audio equipment.

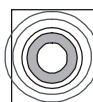

**SPDIF
IN**

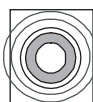

**SPDIF
OUT**

Serial Port Connector: COM A

The mainboard offers one 9-pin male DIN connector as serial port COM A. The port is a 16550A high speed communication port that sends/receives 16 bytes FIFOs. You can attach a serial mouse or other serial devices directly to the connector.

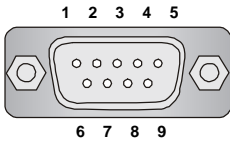

9-Pin Male DIN Connector

Pin Definition

PIN	SIGNAL	DESCRIPTION
1	DCD	Data Carry Detect
2	SIN	Serial In or Receive Data
3	SOUT	Serial Out or Transmit Data
4	DTR	Data Terminal Ready)
5	GND	Ground
6	DSR	Data Set Ready
7	RTS	Request To Send
8	CTS	Clear To Send
9	RI	Ring Indicate

Connectors

The mainboard provides connectors to connect to FDD, IDE HDD, case, modem, LAN, USB Ports, IR module and CPU/System FAN.

Floppy Disk Drive Connector: FDD1

The mainboard provides a standard floppy disk drive connector that supports 360K, 720K, 1.2M, 1.44M and 2.88M floppy disk types.

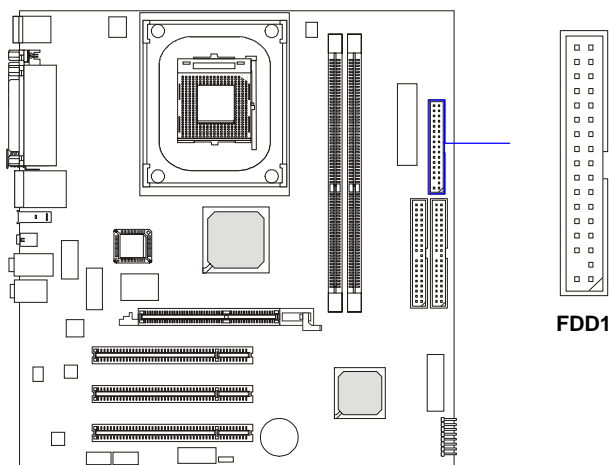

Hard Disk Connectors: IDE1 & IDE2

The mainboard has a 32-bit Enhanced PCI IDE and Ultra DMA 33/66/100/133 controller that provides PIO mode 0~4, Bus Master, and Ultra DMA 33/66/100/133 function. You can connect up to four hard disk drives, CD-ROM, 120MB Floppy (reserved for future BIOS) and other devices.

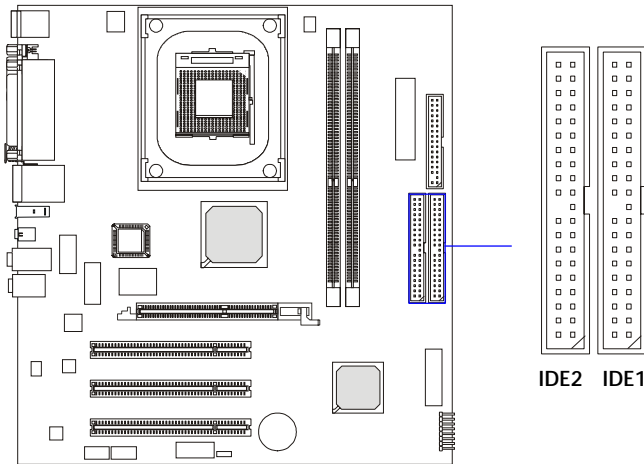

IDE1 (Primary IDE Connector)

The first hard drive should always be connected to IDE1. IDE1 can connect a Master and a Slave drive. You must configure second hard drive to Slave mode by setting the jumper accordingly.

IDE2 (Secondary IDE Connector)

IDE2 can also connect a Master and a Slave drive.



MSI Reminds You...

If you install two hard disks on cable, you must configure the second drive to Slave mode by setting its jumper. Refer to the hard disk documentation supplied by hard disk vendors for jumper setting instructions.

Fan Power Connector: CPUFAN1

The CPUFAN1 (processor fan) supports system cooling fan with +12V. It supports a three-pin head connector. When connecting the wire to the connector, always take note that the red wire is the positive and should be connected to the +12V, the black wire is Ground and should be connected to GND. If the mainboard has a System Hardware Monitor chipset on-board, you must use a specially designed fan with speed sensor to take advantage of the CPU fan control.

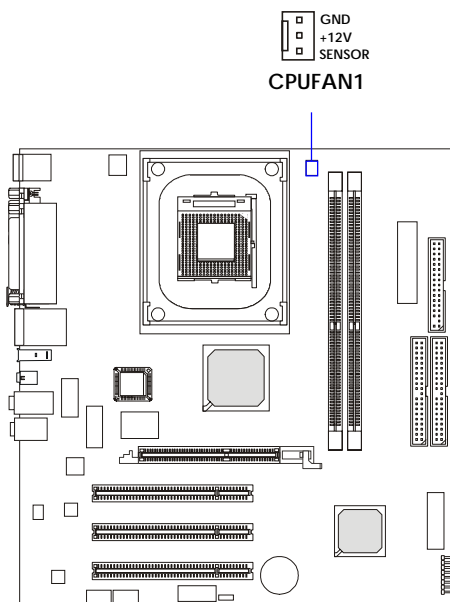

MSI Reminds You...

- 1. Always consult the vendors for proper CPU cooling fan.*
- 2. CPUFAN supports the fan control. You can install the PC Alert utility that will automatically control the CPU fan speed according to the actual CPU temperature.*

Front Panel Connector: F_P1

The mainboard provides one front panel connector for electrical connection to the front panel switches and LEDs.

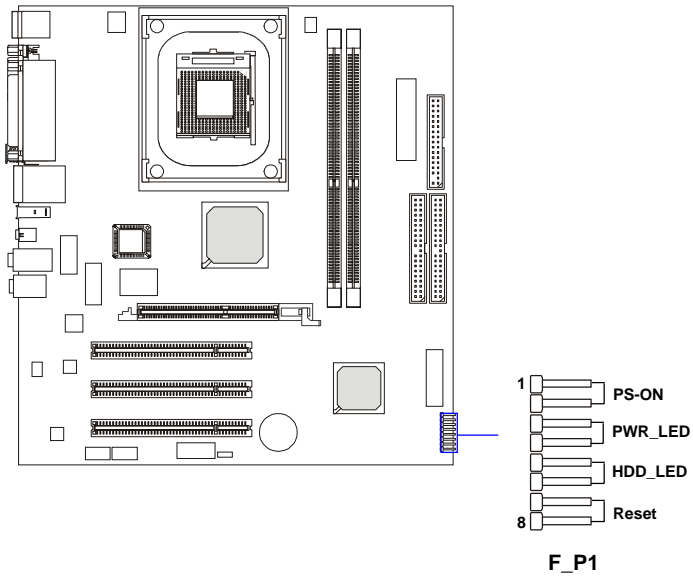

Front Panel Audio Connector: JAUDIO1

The JAUDIO1 front panel audio connector allows you to connect to the front panel audio and is compliant with Intel® Front Panel I/O Connectivity Design Guide.

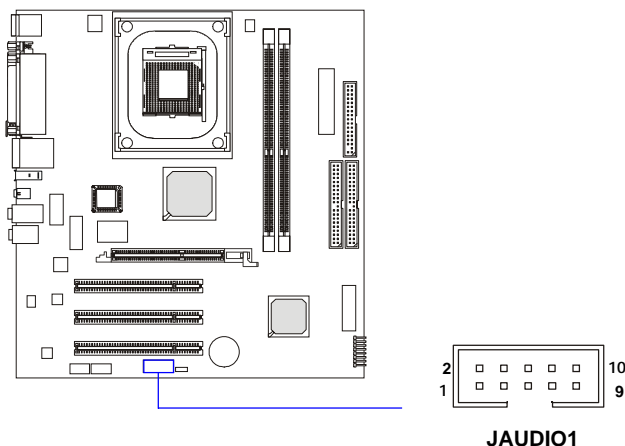

JAUDIO1 Pin Definition

Pin	Description	Pin	Description
1	Speaker_R	2	Front_R
3	Speaker_L	4	Front_L
5	GND	6	GND
7	MIC_IN	8	Line_Next_R
9	MIC_IN_S	10	Line_Next_L



MSI Reminds You...

If you don't want to connect to the front audio header, pins 1 & 2, 3 & 4 have to be jumpered in order to have signal output directed to the rear audio ports. Otherwise, the Line-Out connector on the back panel will not function.



Front USB Connector: JUSB1

The mainboard provides one front Universal Serial Bus connector for users to connect USB devices.

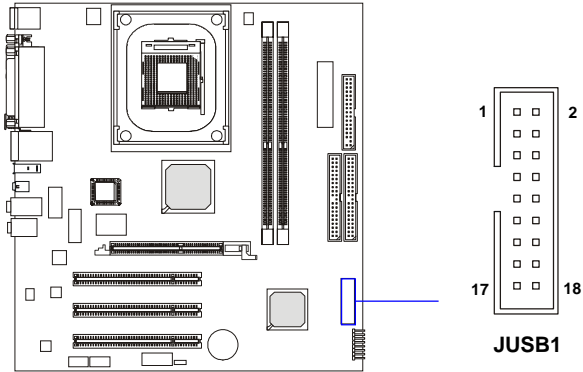

JUSB1 Pin Definition

Pin	Description	Pin	Description
1	Power	2	Power
3	D1+	4	D0+
5	D1-	6	D0-
7	GND	8	GND
9	SGND	10	SGND
11	GND	12	GND
13	D3-	14	D2-
15	D3+	16	D2+
17	Power	18	Power

CD-In Connector: JCD1

The connector is for CD-ROM audio connector.

Audio Connector: JVEDIO1

This connector allows you to connect to a TV Tuner Card.

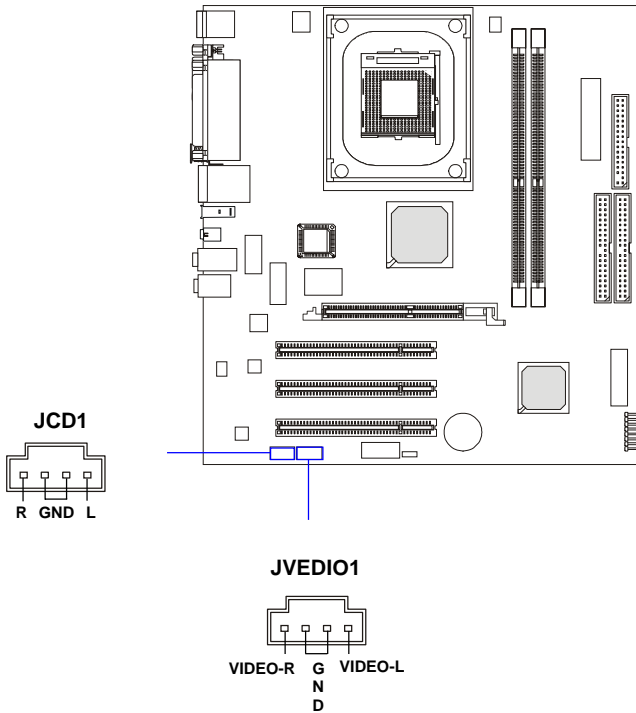

SPDIF Connector: JSPDIF1

The connector is used to connect an optional bracket for SPDIF (Sony & Philips Digital Interconnect Format) digital audio transmission.

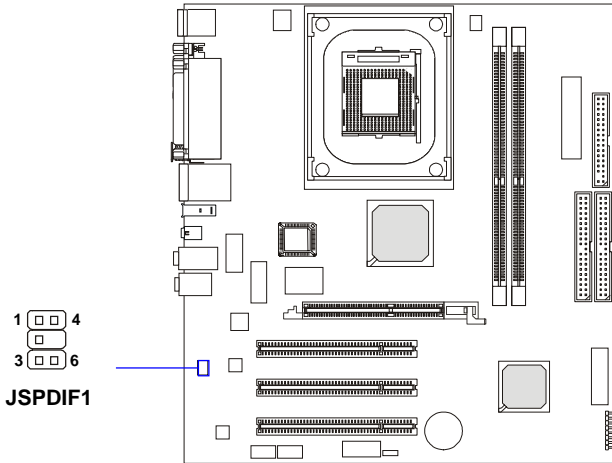

JSPDIF1 Pin Definition

Pin	Description	Pin	Description
1	VCC5	2	VCC3
3	SPDIF-O	4	NC
5	GND	6	SPDIF-I

IEEE 1394 Connector: J7 (Optional)

The mainboard provides one IEEE1394 connector with housing that allows you to connect optional IEEE 1394 ports.

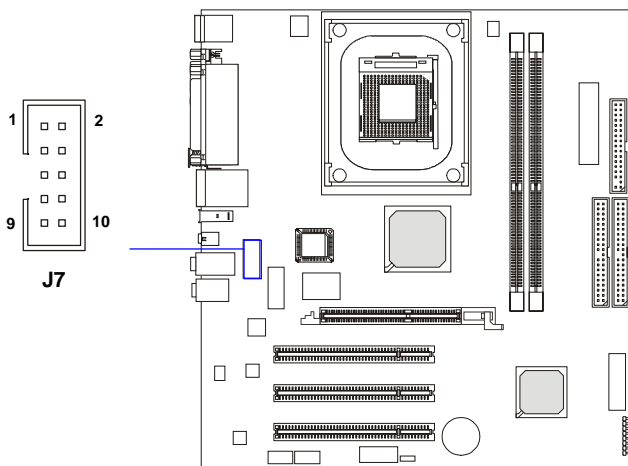

Pin Definition

PIN	SIGNAL	PIN	SIGNAL
1	IEGND	2	GND
3	TPA0-	4	TPA0+
5	Power	6	Power
7	TPB0+	8	TPB0-
9	GND	10	IEGND

Joystick/Game Connector: J9 (Optional)

You can connect a joystick or game pad to this connector.

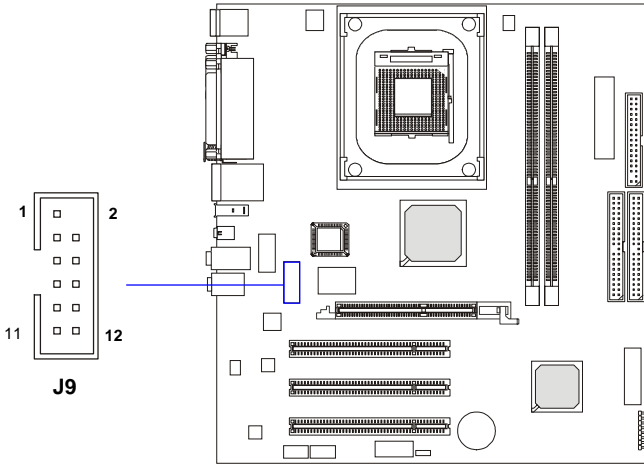

J9 Pin Definition

Pin	Description	Pin	Description
1	FVCC5 (power)	2	Key pin
3	RXD	4	GP4
5	GP5	6	GP6
7	GP7	8	GP2
9	GP1	10	GP0
11	GP3	12	TXD

Jumpers

The motherboard provides the following jumpers for you to set the computer's function. This section will explain how to change your motherboard's function through the use of jumpers.

Clear CMOS Jumper: JBAT1

There is a CMOS RAM on board that has a power supply from external battery to keep the data of system configuration. With the CMOS RAM, the system can automatically boot OS every time it is turned on. If you want to clear the system configuration, use the JBAT1 (Clear CMOS Jumper) to clear data. Follow the instructions below to clear the data:

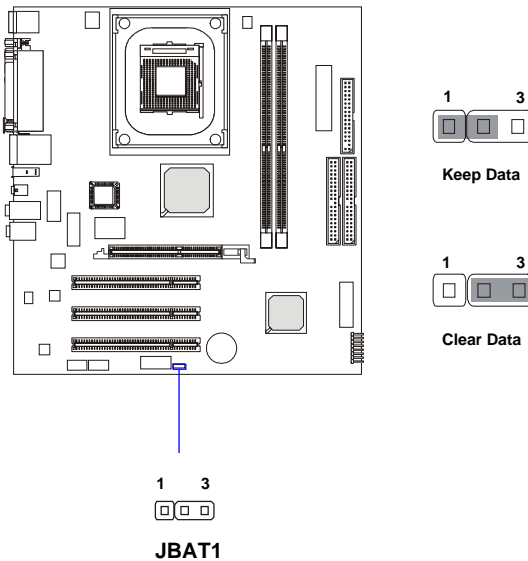

MSI Reminds You...

You can clear CMOS by shorting 2-3 pin while the system is off. Then return to 1-2 pin position. Avoid clearing the CMOS while the system is on; it will damage the mainboard.

Slots

The motherboard provides one AGP slot and three 32-bit PCI bus slots.

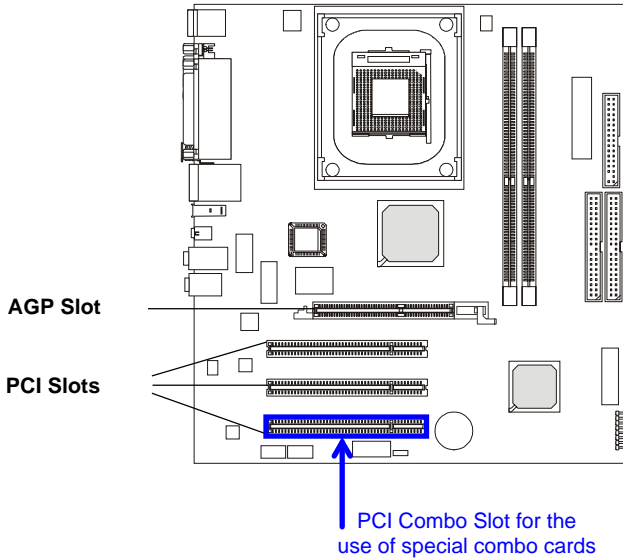

AGP (Accelerated Graphics Port) Slot

The AGP slot allows you to insert the AGP graphics card. AGP is an interface specification designed for the throughput demands of 3D graphics. It introduces a 66MHz, 32-bit channel for the graphics controller to directly access main memory. The mainboard supports 4x/8x 1.5V AGP card.

PCI (Peripheral Component Interconnect) Slots

The PCI slots allow you to insert the expansion cards to meet your needs. When adding or removing expansion cards, make sure that you unplug the power supply first. Meanwhile, read the documentation for the expansion card to make any necessary hardware or software settings for the expansion card, such as jumpers, switches or BIOS configuration. The third PCI slot supports 2 master devices.

PCI Interrupt Request Routing

The IRQ, acronym of interrupt request line and pronounced I-R-Q, are hardware lines over which devices can send interrupt signals to the microprocessor. The PCI IRQ pins are typically connected to the PCI bus INT A# ~ INT D# pins as follows:

	Order 1	Order 2	Order 3	Order 4
PCI Slot 1	INT B#	INT C#	INT D#	INT A#
PCI Slot 2	INT C#	INT D#	INT A#	INT B#
PCI Slot 3	INT D#	INT A#	INT B#	INT C#